

US00D497114S1

(12) **United States Design Patent** (10) **Patent No.:** **US D497,114 S**
Willcox (45) **Date of Patent:** **** Oct. 12, 2004**

(54) **TOTAL AIR TEMPERATURE PROBE**

(75) Inventor: **Charles R. Willcox**, Eden Prairie, MN (US)

(73) Assignee: **Rosemount Aerospace Inc.**, Burnsville, MN (US)

(**) Term: **14 Years**

(21) Appl. No.: **29/180,878**

(22) Filed: **Apr. 30, 2003**

(51) **LOC (7) Cl.** **10-04**

(52) **U.S. Cl.** **D10/96**

(58) **Field of Search** D10/96, 103; 73/861.65, 73/861.66, 861.67, 861.68

(56) **References Cited**

U.S. PATENT DOCUMENTS

2,970,475	A	2/1961	Werner	
4,268,284	A *	5/1981	Kent et al.	55/428.1
4,644,806	A *	2/1987	Flagg et al.	73/863.58
5,025,661	A *	6/1991	McCormack	73/180
5,233,865	A *	8/1993	Rosow	73/147
5,302,026	A	4/1994	Phillips	
5,331,849	A *	7/1994	Hedberg et al.	73/182
5,653,538	A *	8/1997	Phillips	374/138
5,969,266	A *	10/1999	Mahoney et al.	73/861.65
2003/0005779	A1	1/2003	Bernard	

OTHER PUBLICATIONS

Supplemental Declaration of Donald Thompson from Trademark Application Ser. No. 74/313,914 showing and describing photographs of total air temperature probes (Jun. 19, 1994).

Color copy of photograph of Rosemount England Model E22014 total air temperature probe (date unknown).

Color copy of photograph of Rosemount Aerospace Model 101F total air temperature probe (date unknown).

Color copy of photograph of Rosemount Aerospace Model 154CD2 total air temperature probe (date unknown).

(List continued on next page.)

Primary Examiner—Antoine D. Davis

(74) *Attorney, Agent, or Firm*—Merchant & Gould P.C.

(57) **CLAIM**

The ornamental design for total air temperature probe, as shown and described.

DESCRIPTION

FIG. 1 is a front top right perspective view of a first embodiment of a total air temperature probe.

FIG. 2 is a front view of the first embodiment shown in FIG. 1.

FIG. 3 is a back view of the first embodiment.

FIG. 4 is a right view of the first embodiment.

FIG. 5 is a left view of the first embodiment.

FIG. 6 is a top view of the first embodiment.

FIG. 7 is a bottom view of the first embodiment.

FIG. 8 is a front top right perspective view of a second embodiment of a total air temperature probe.

FIG. 9 is a front view of the second embodiment shown in FIG. 8.

FIG. 10 is a back view of the second embodiment.

FIG. 11 is a right view of the second embodiment.

FIG. 12 is a left view of the second embodiment.

FIG. 13 is a top view of the second embodiment.

FIG. 14 is a bottom view of the second embodiment.

FIG. 15 is a front top right perspective view of a third embodiment of a total air temperature probe.

FIG. 16 is a front view of the third embodiment shown in FIG. 15.

FIG. 17 is a back view of the third embodiment.

FIG. 18 is a right view of the third embodiment.

FIG. 19 is a left view of the third embodiment.

FIG. 20 is a top view of the third embodiment; and,

FIG. 21 is a bottom view of the third embodiment.

The broken line showing is for illustrative purposes only and forms no part of the claimed design.

1 Claim, 12 Drawing Sheets

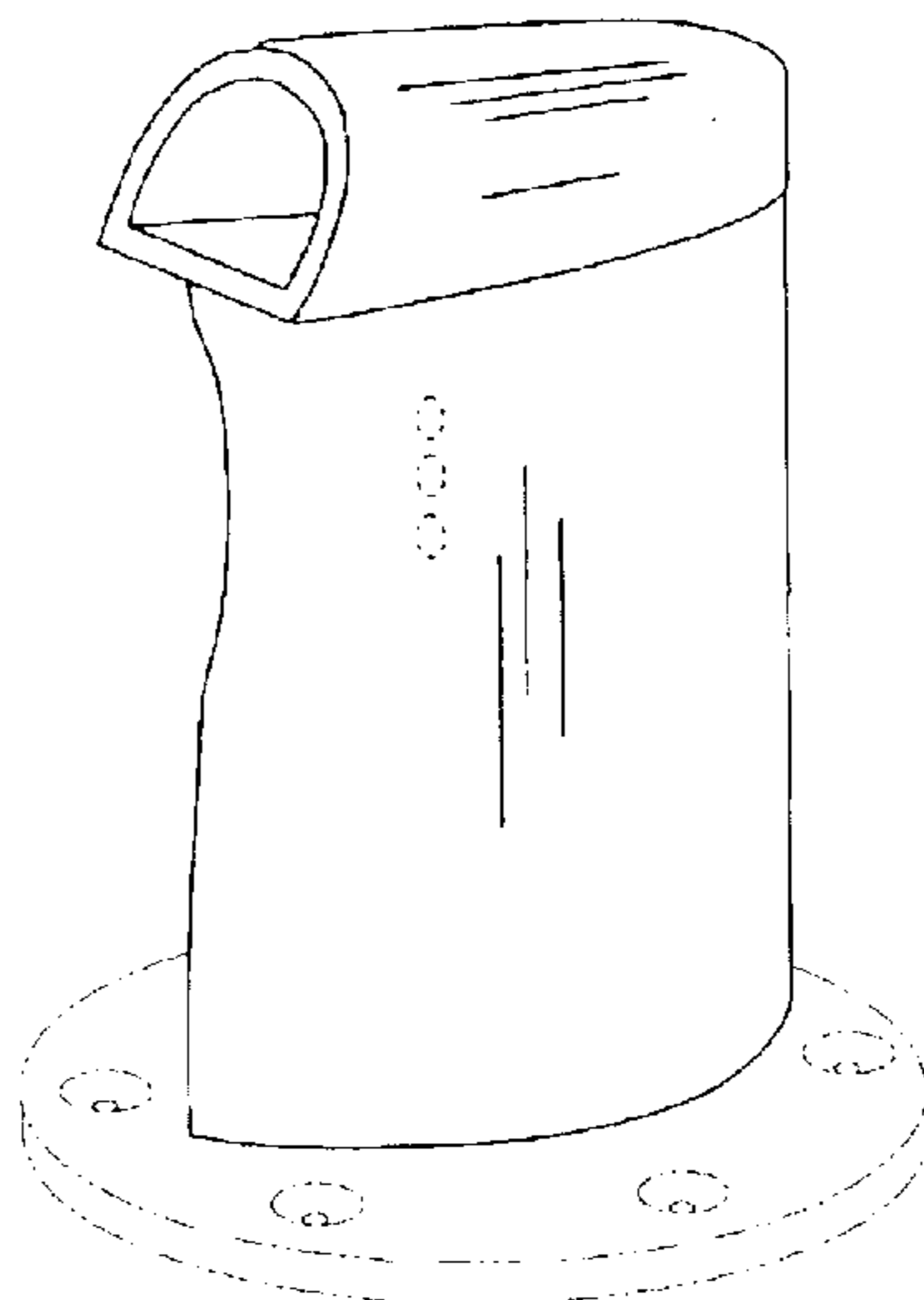

OTHER PUBLICATIONS

Color copy of photograph of Rosemount Aerospace Model 154FK total air temperature probe and Rosemount Aerospace Model 154AL total air temperature probe, front view (date unknown).

Color copy of photograph of Rosemount Aerospace Model 154FK total air temperature probe and Rosemount Aerospace Model 154AL total air temperature probe, front lower left perspective view (date unknown).

Color copy of photograph of Rosemount Aerospace Model 135L total air temperature probe (date unknown).

Color copy of photograph of Auxitrol Model RP152 total air temperature probe, front right perspective view (date unknown).

Color copy of photograph of Auxitrol Model RP152 total air temperature probe, front view (date unknown).

Color copy of photograph of Auxitrol Model RP159 total air temperature probe (date unknown).

Color copy of photograph of Rosemount Aerospace Model 102AU1AP total air temperature probe (date unknown).

Color copy of photograph of Rosemount Aerospace Model 154ED total air temperature probe (date unknown).

“BFGoodrich Aerospace Aircraft Sensors—Brochure 1034,” *BFGoodrich Aerospace Aircraft Sensors*, © Rosemount Aerospace, Inc., 12 pgs. (Revised Jul. 1998).

“Model 101 and 102 Total Temperature Sensors—Bulletin 1012,” *BF Goodrich Aerospace, Rosemount Aerospace, Inc.*, pp. 1–8 (Revised Feb. 1996).

“Sensors for Aircraft Turbine Engines—Brochure 1060,” *BFGoodrich Aerospace Aircraft Sensors*, 4 pgs. (Nov. 1998).

* cited by examiner

FIG. 1

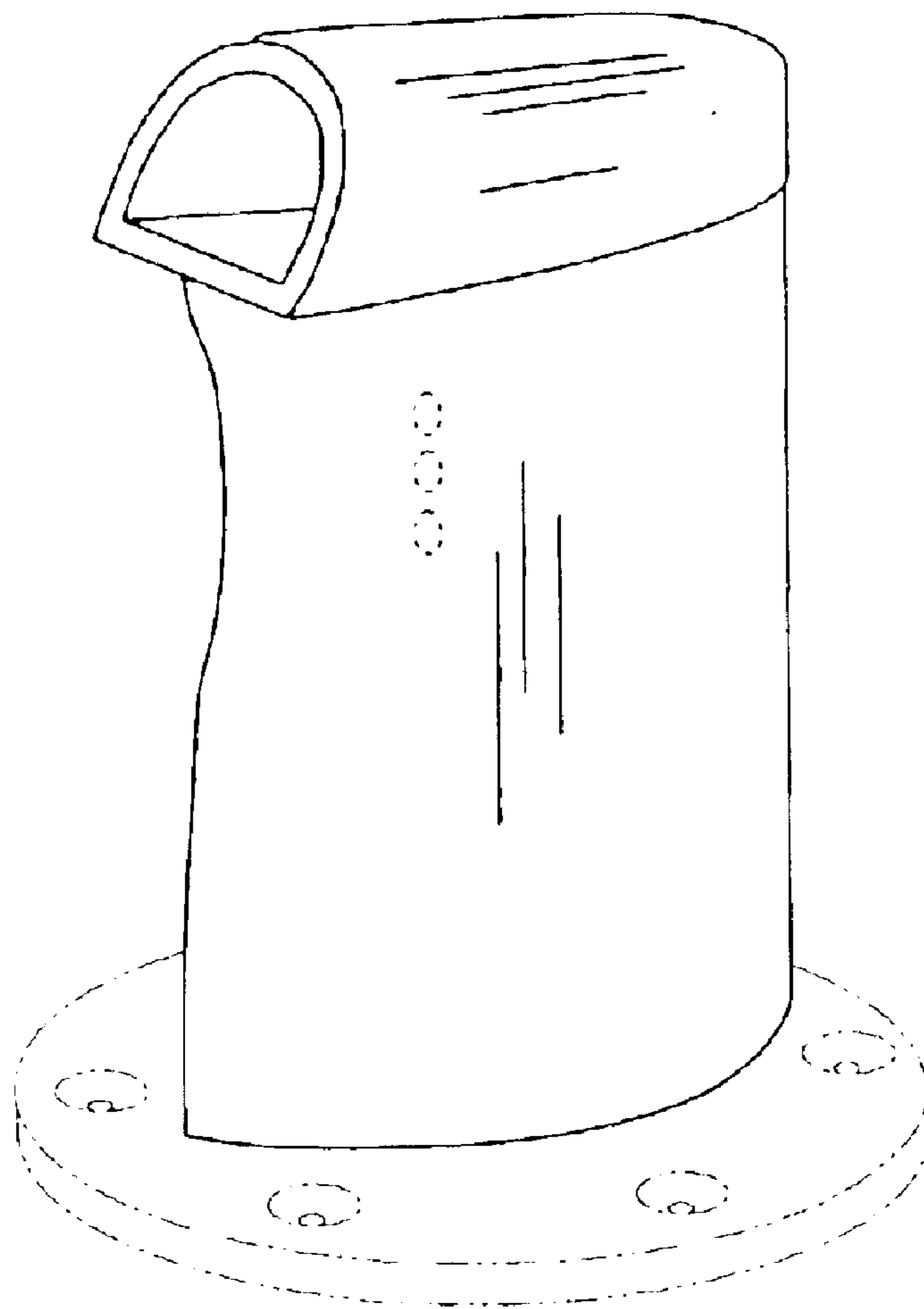

FIG.2

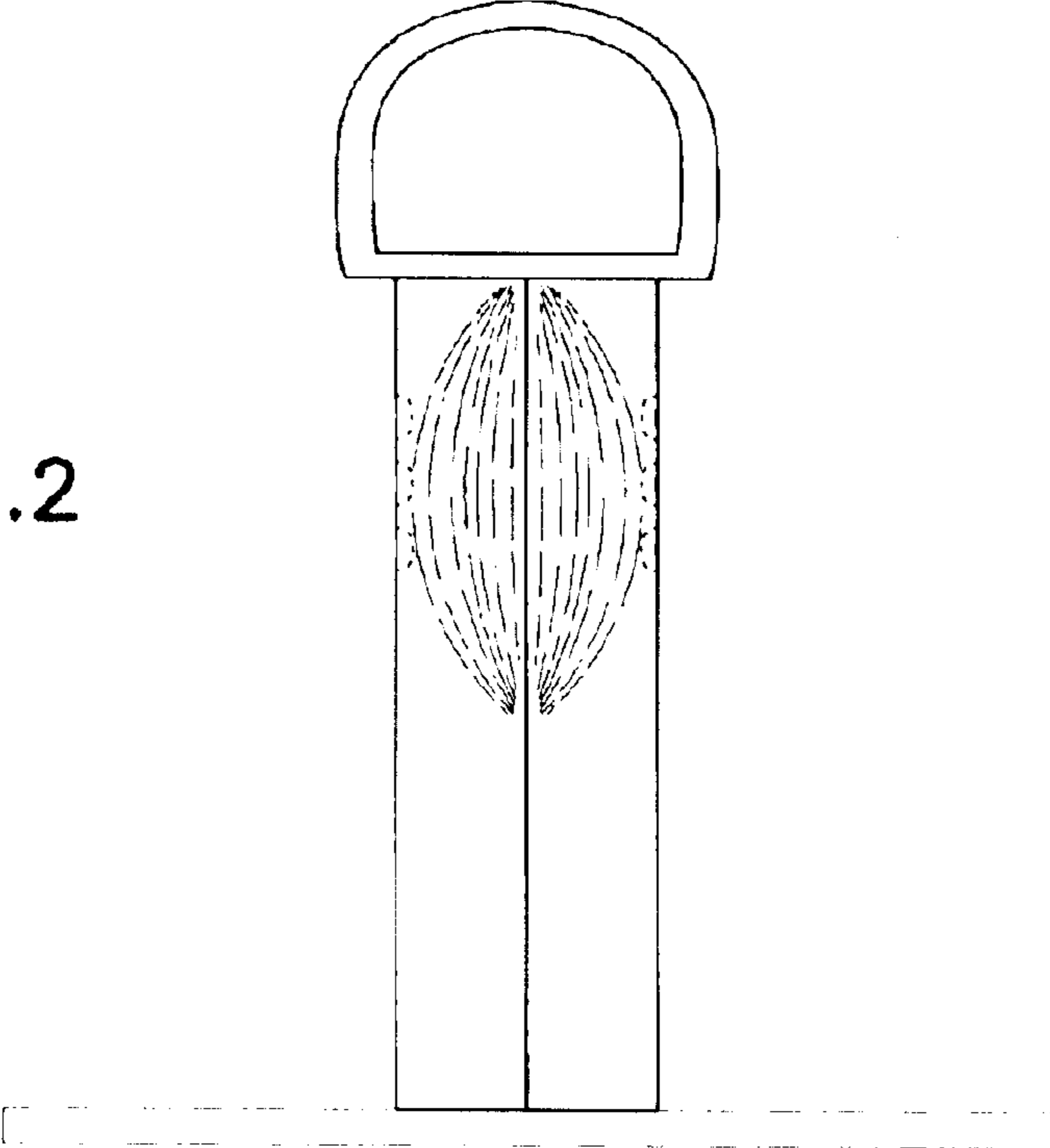

FIG.3

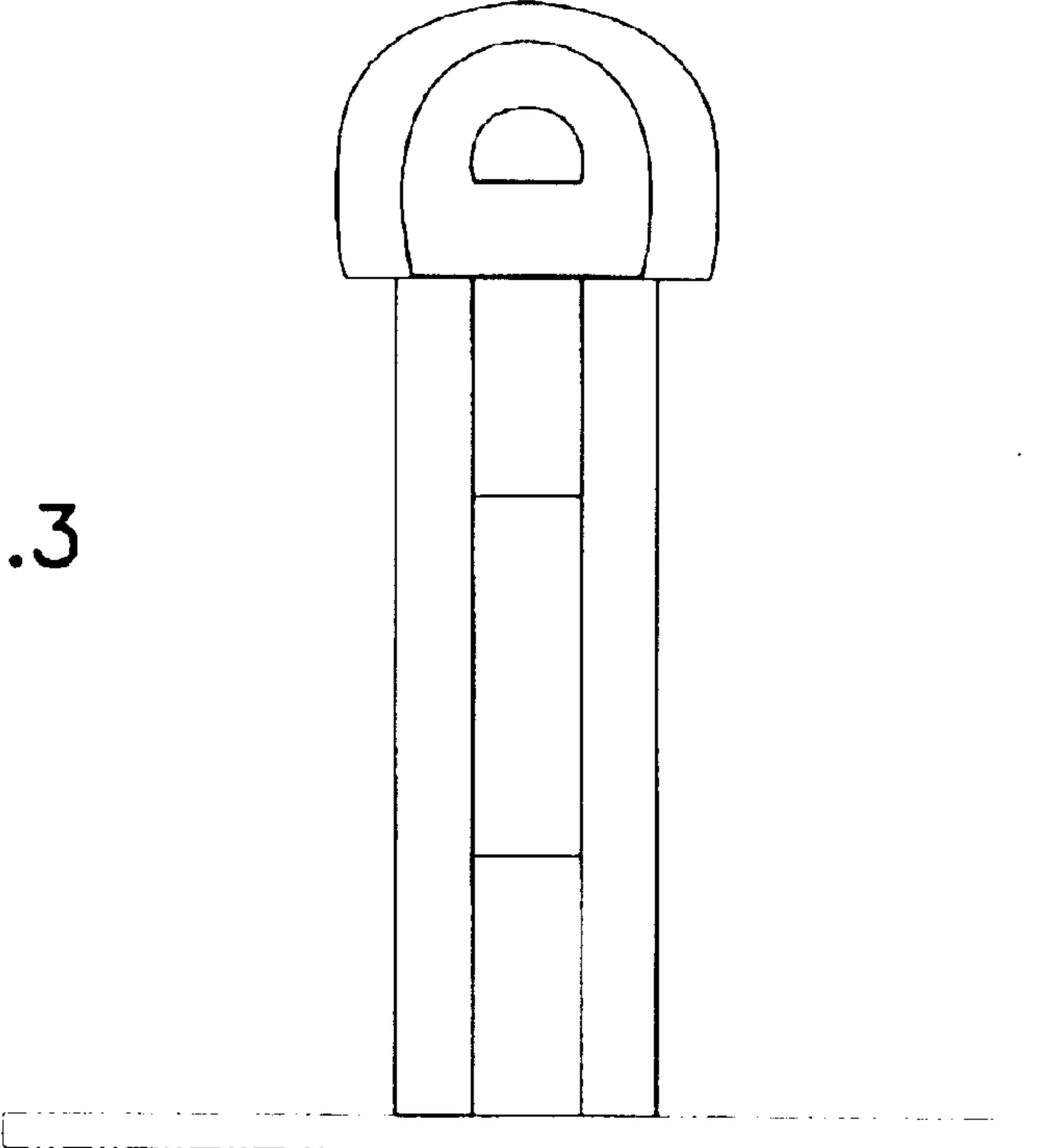

FIG.4

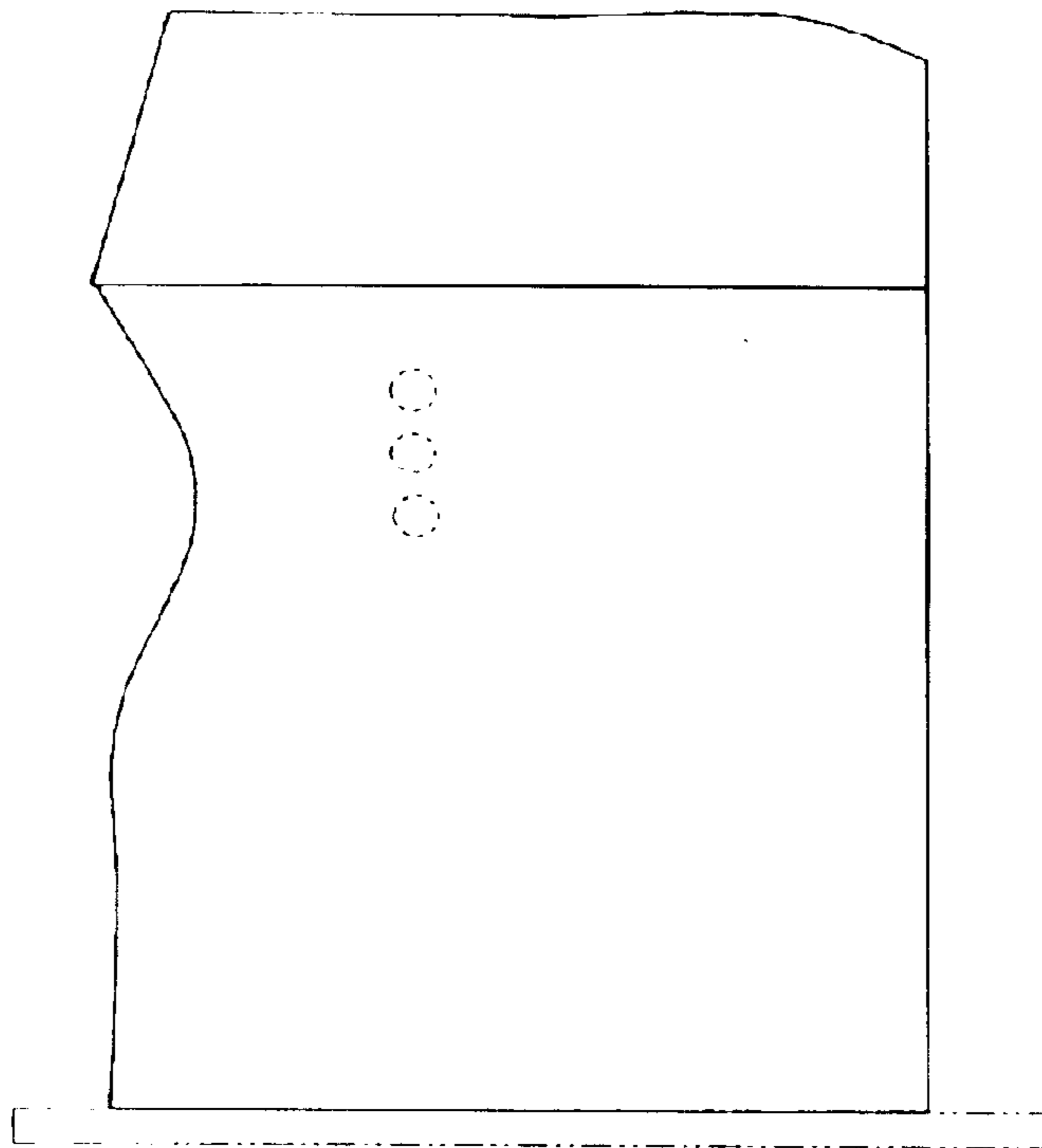

FIG.5

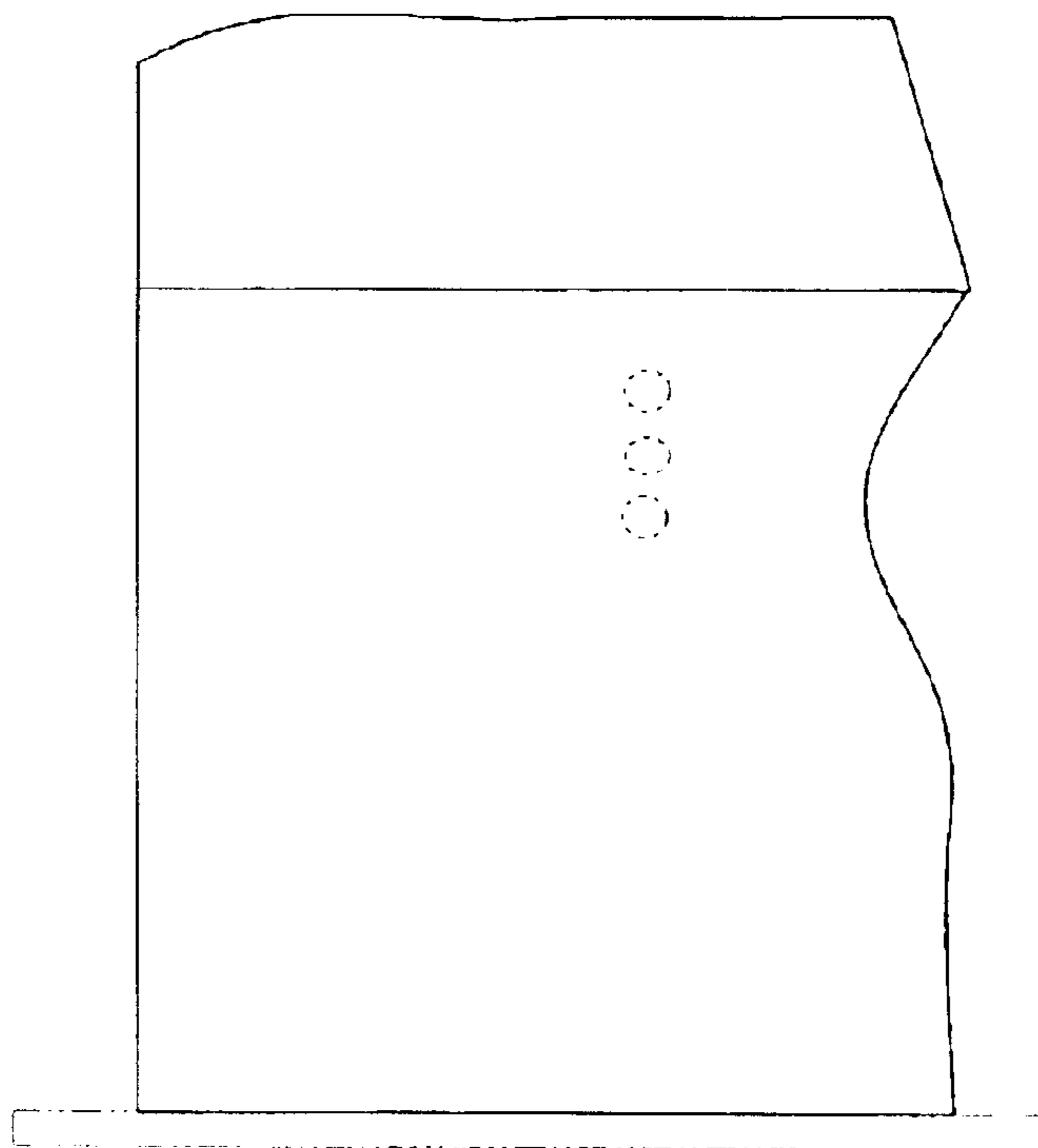

FIG.6

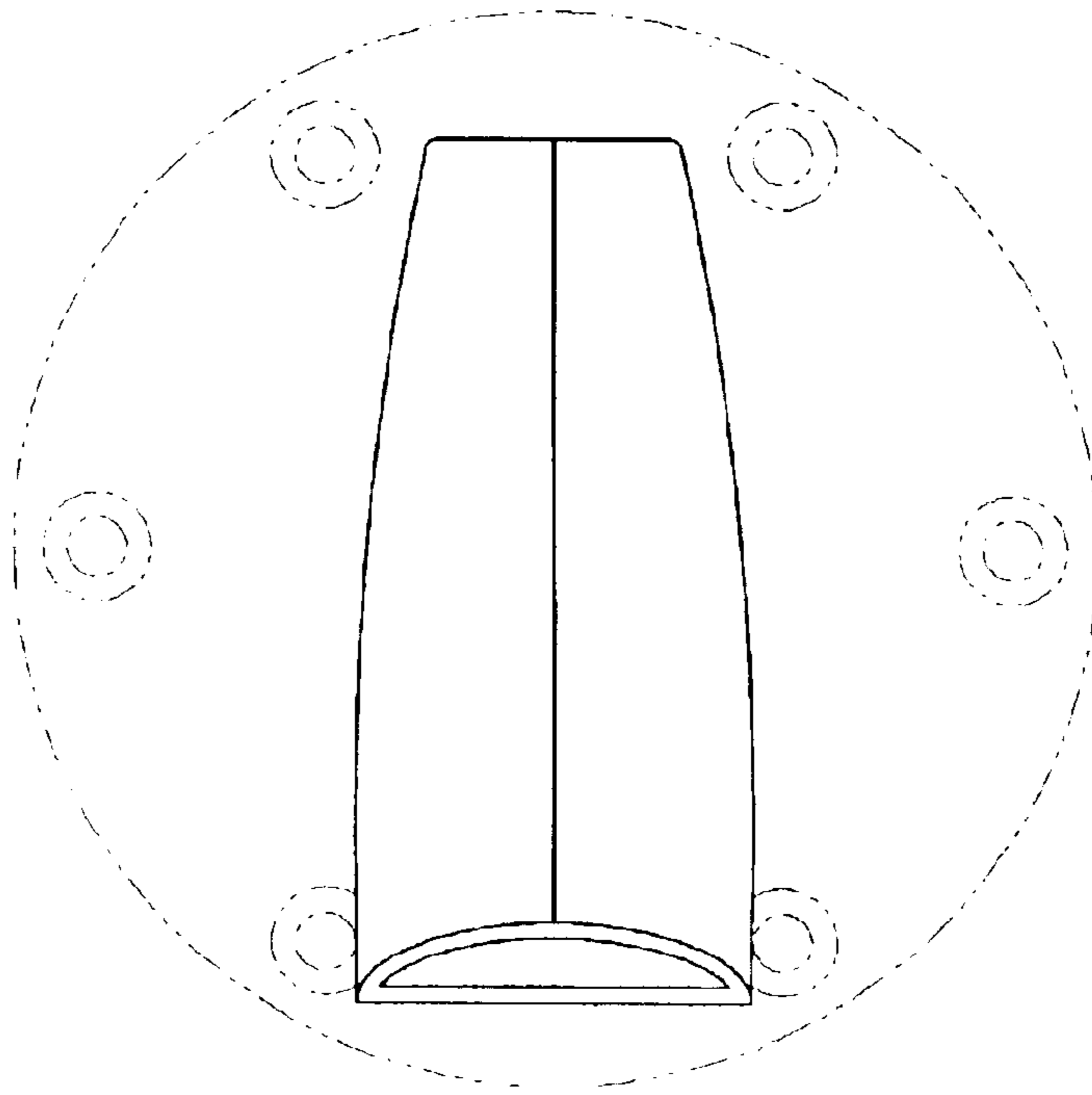

FIG.7

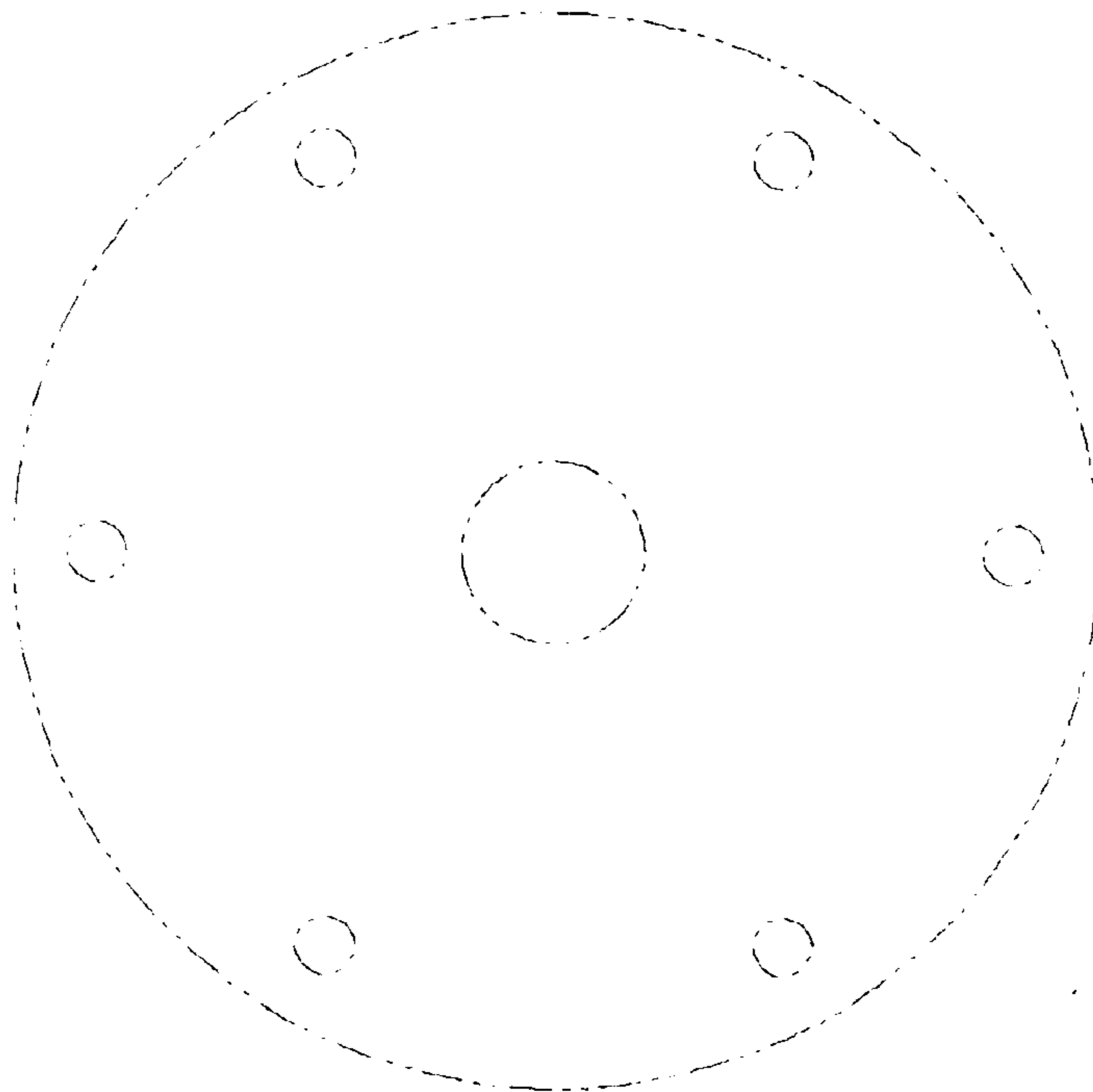

FIG.8

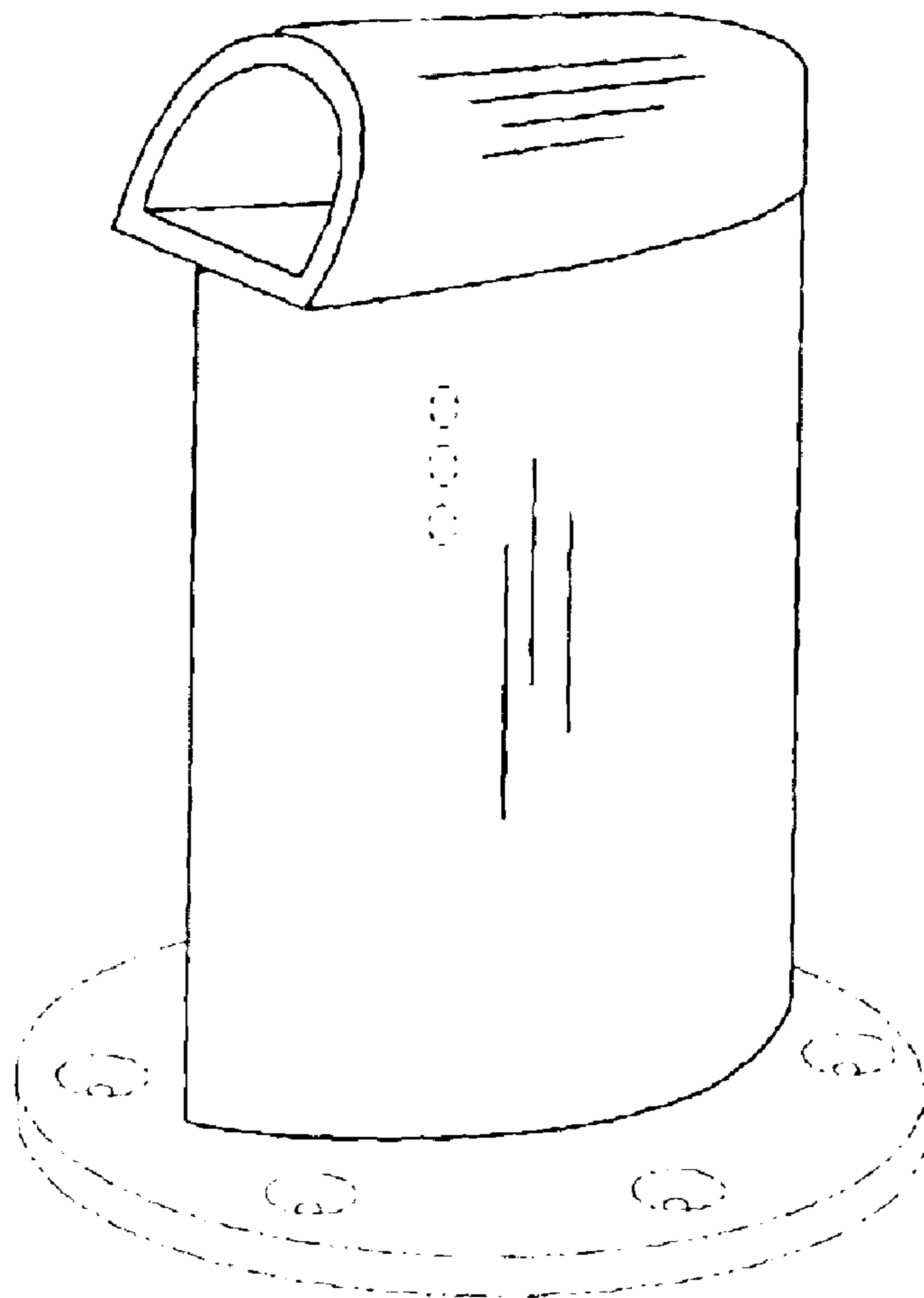

FIG.9

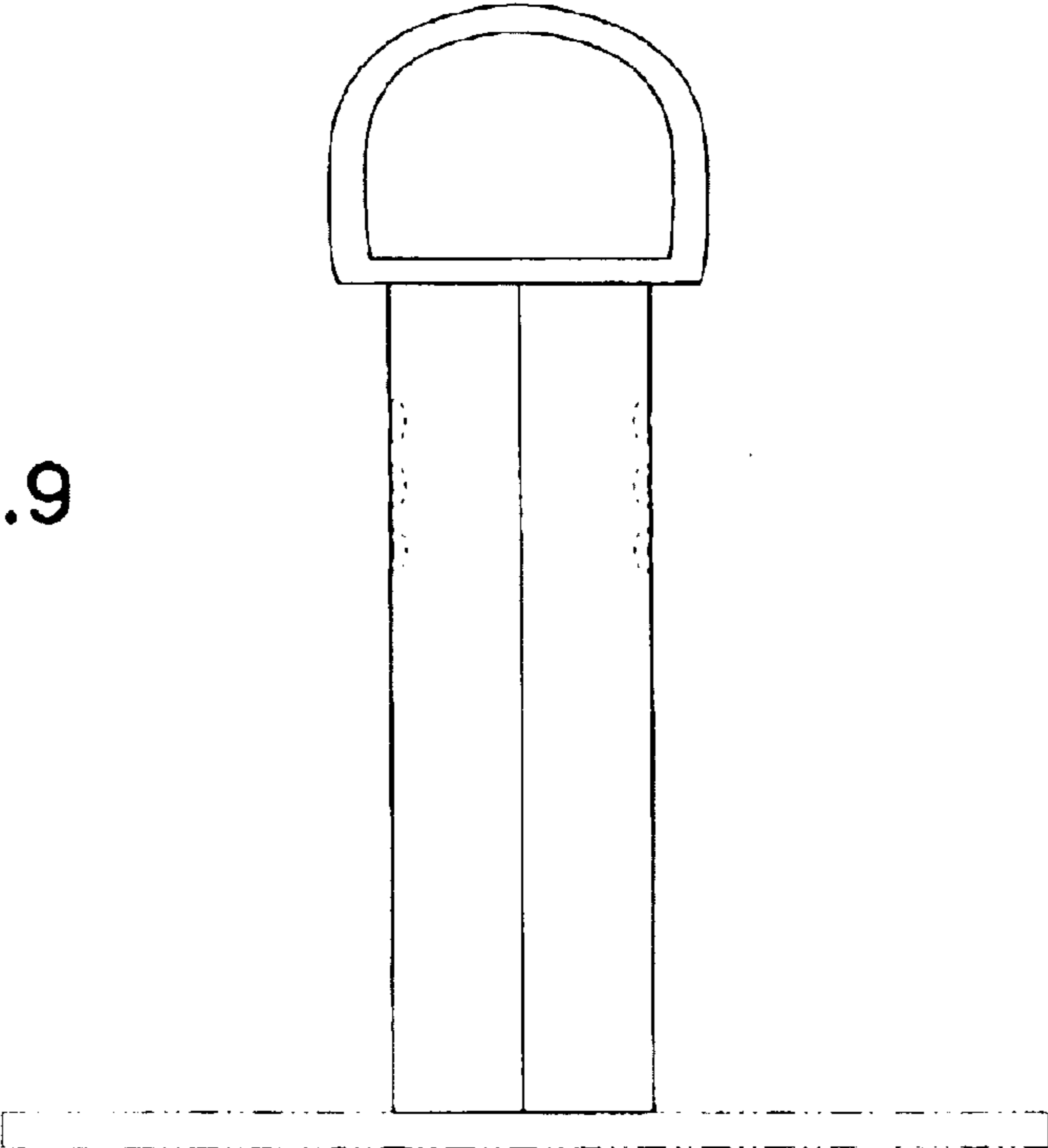

FIG.10

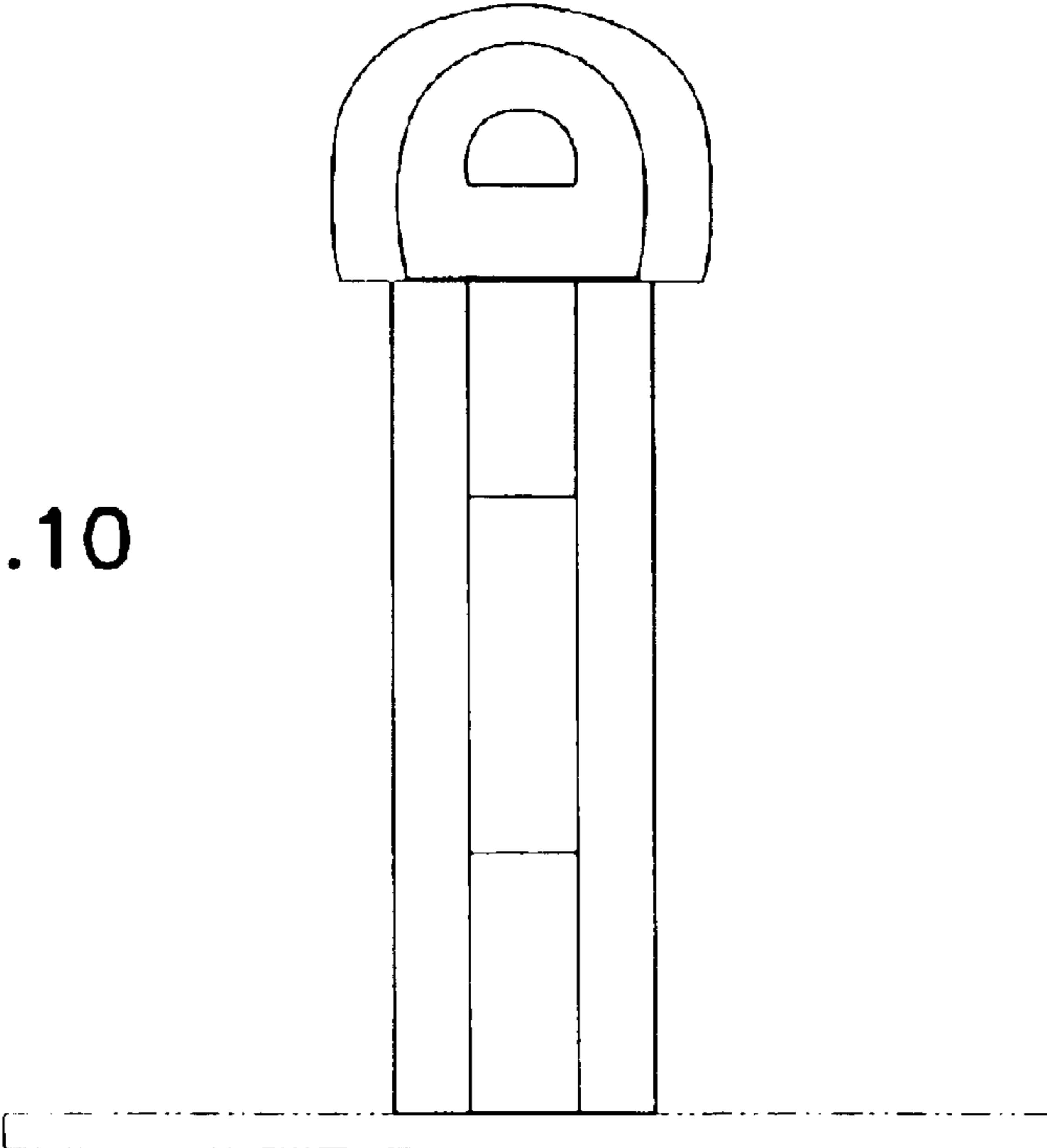

FIG.11

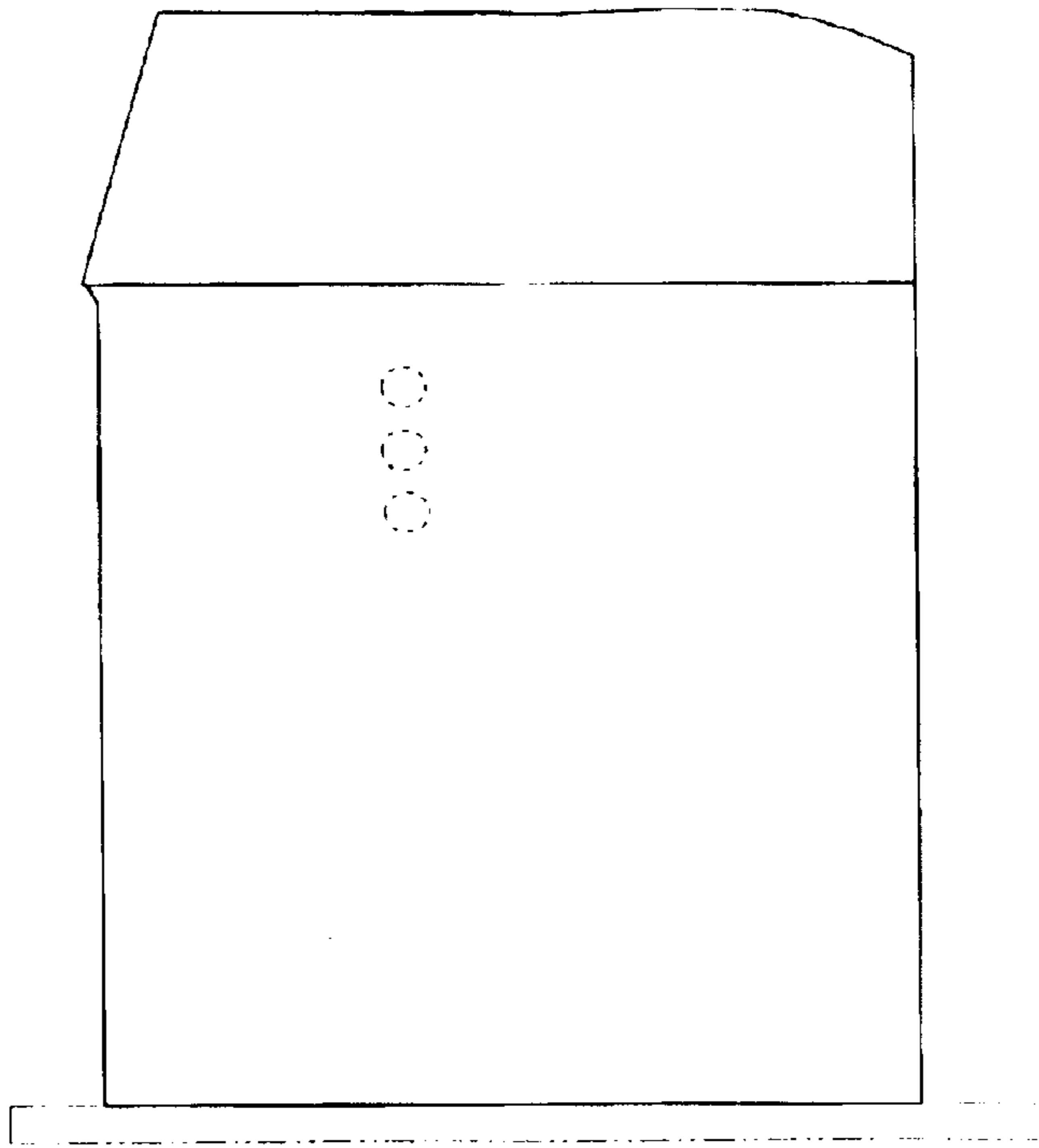

FIG.12

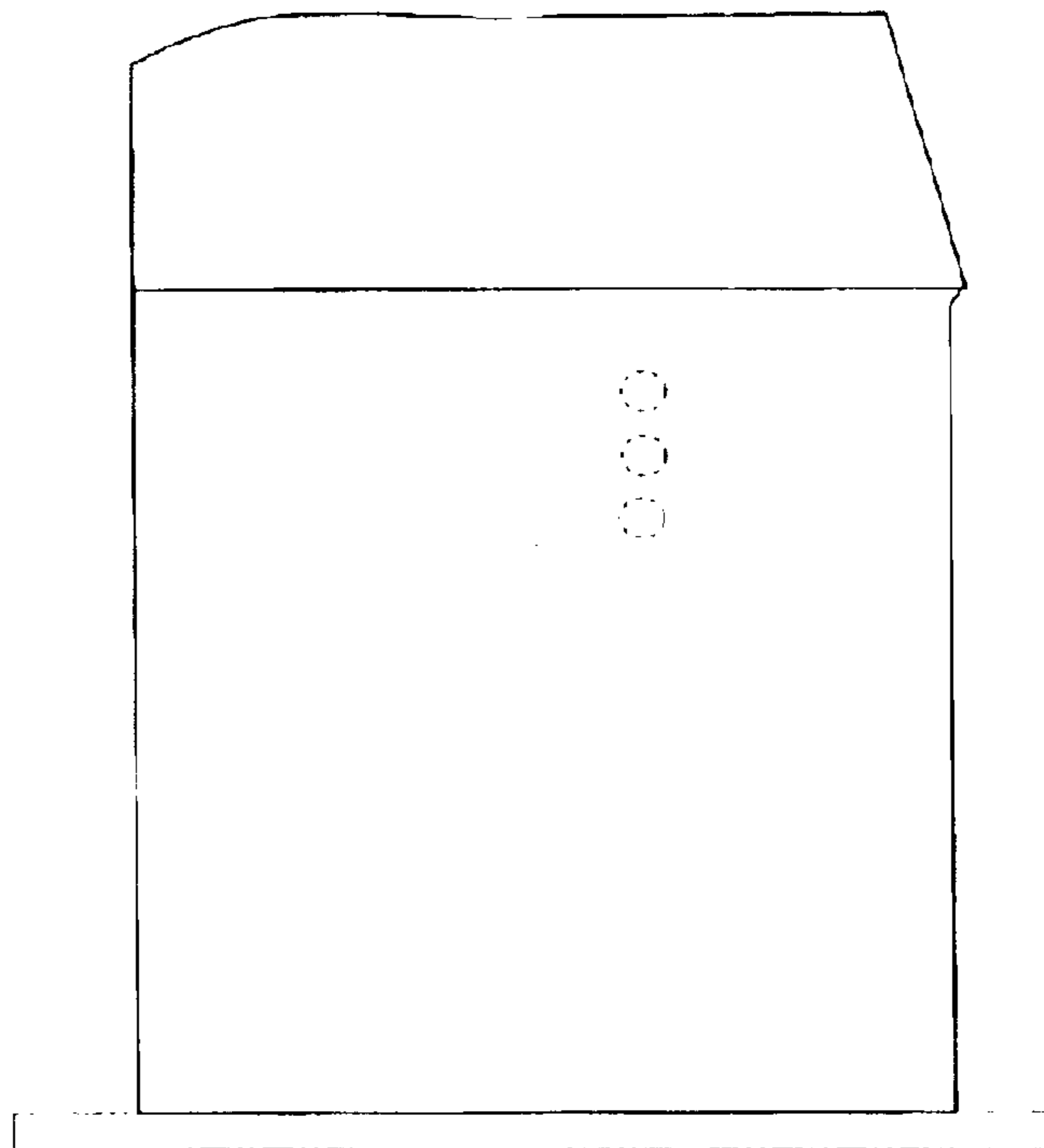

FIG.13

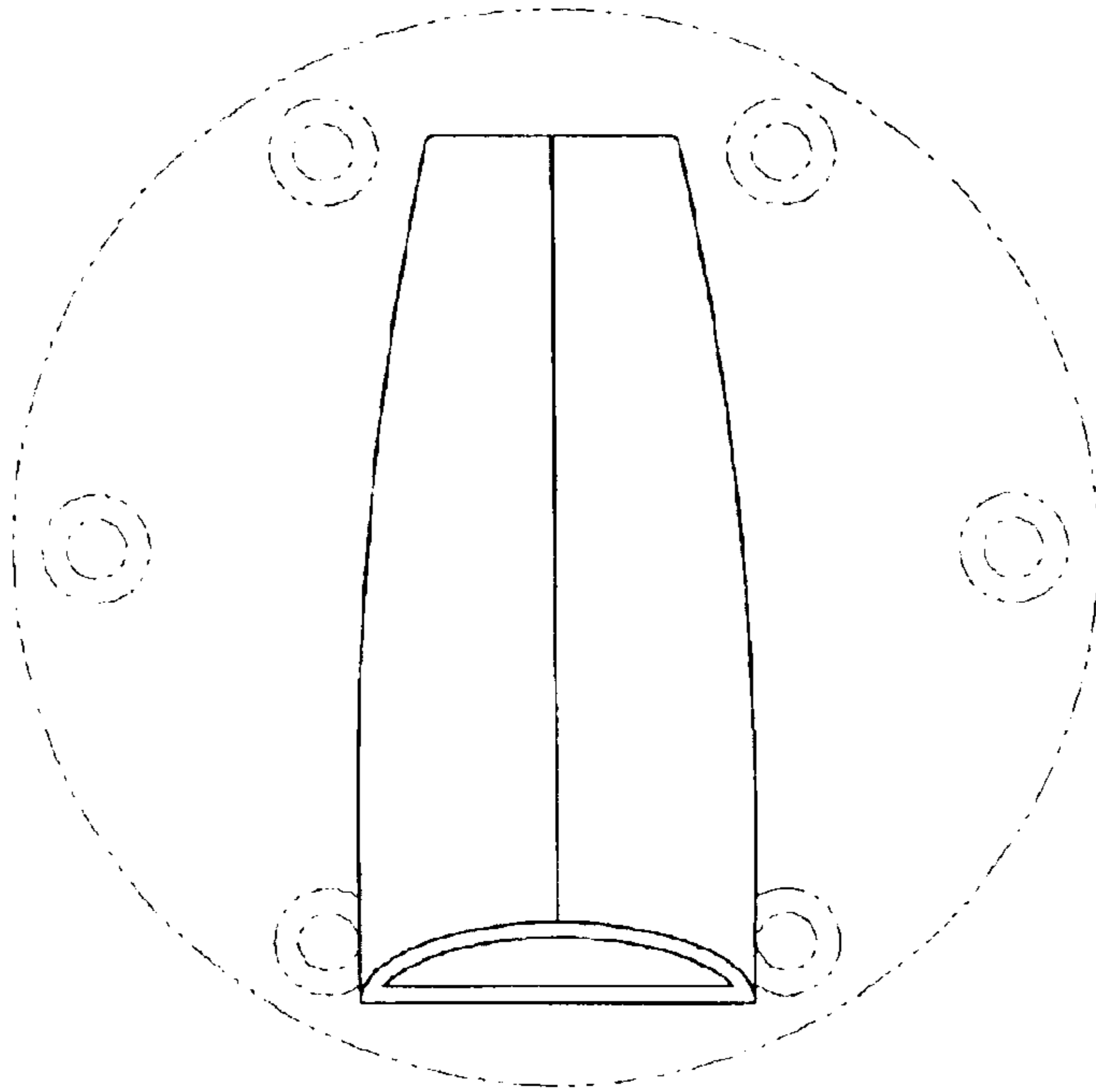

FIG.14

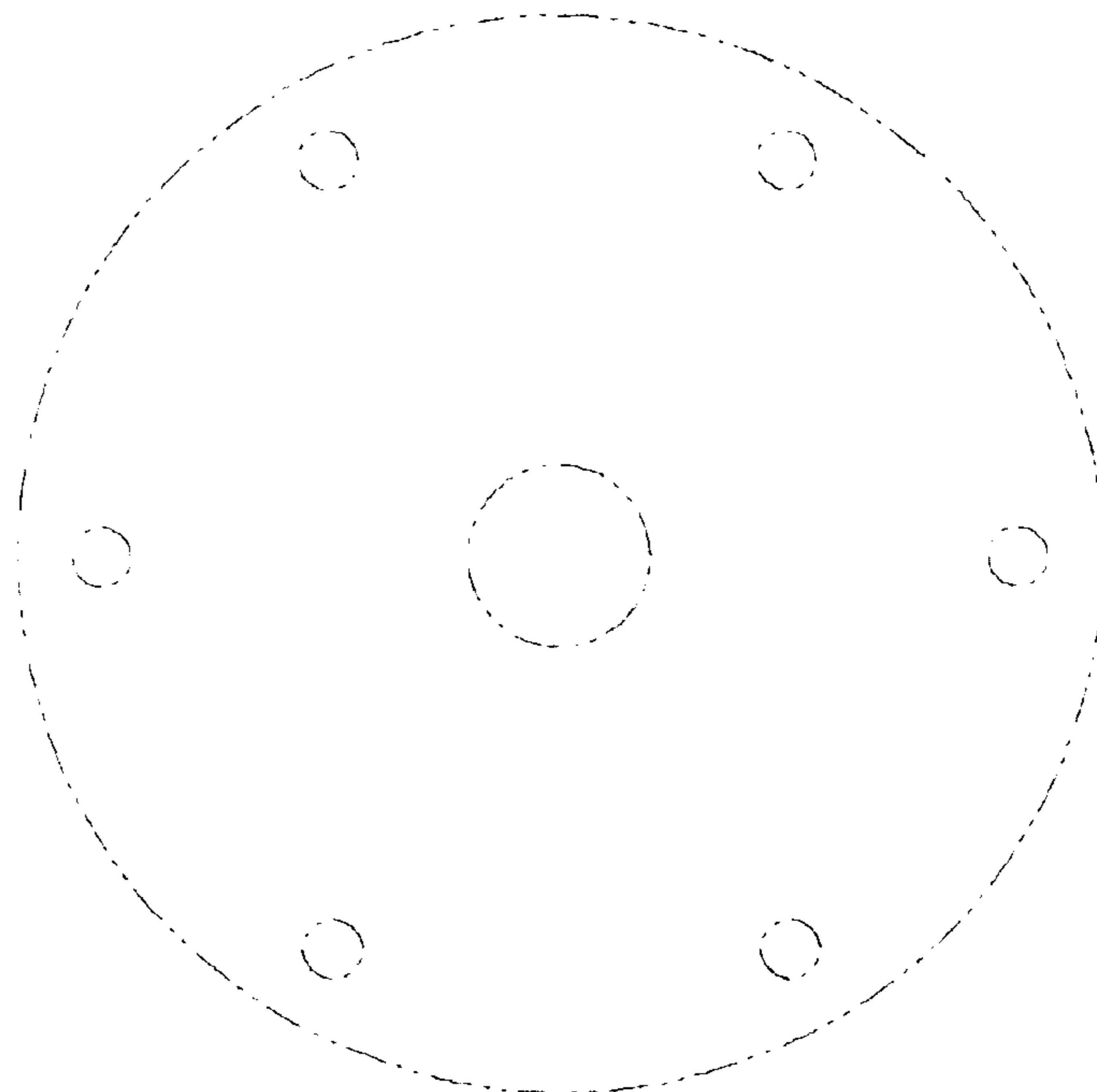

FIG. 15

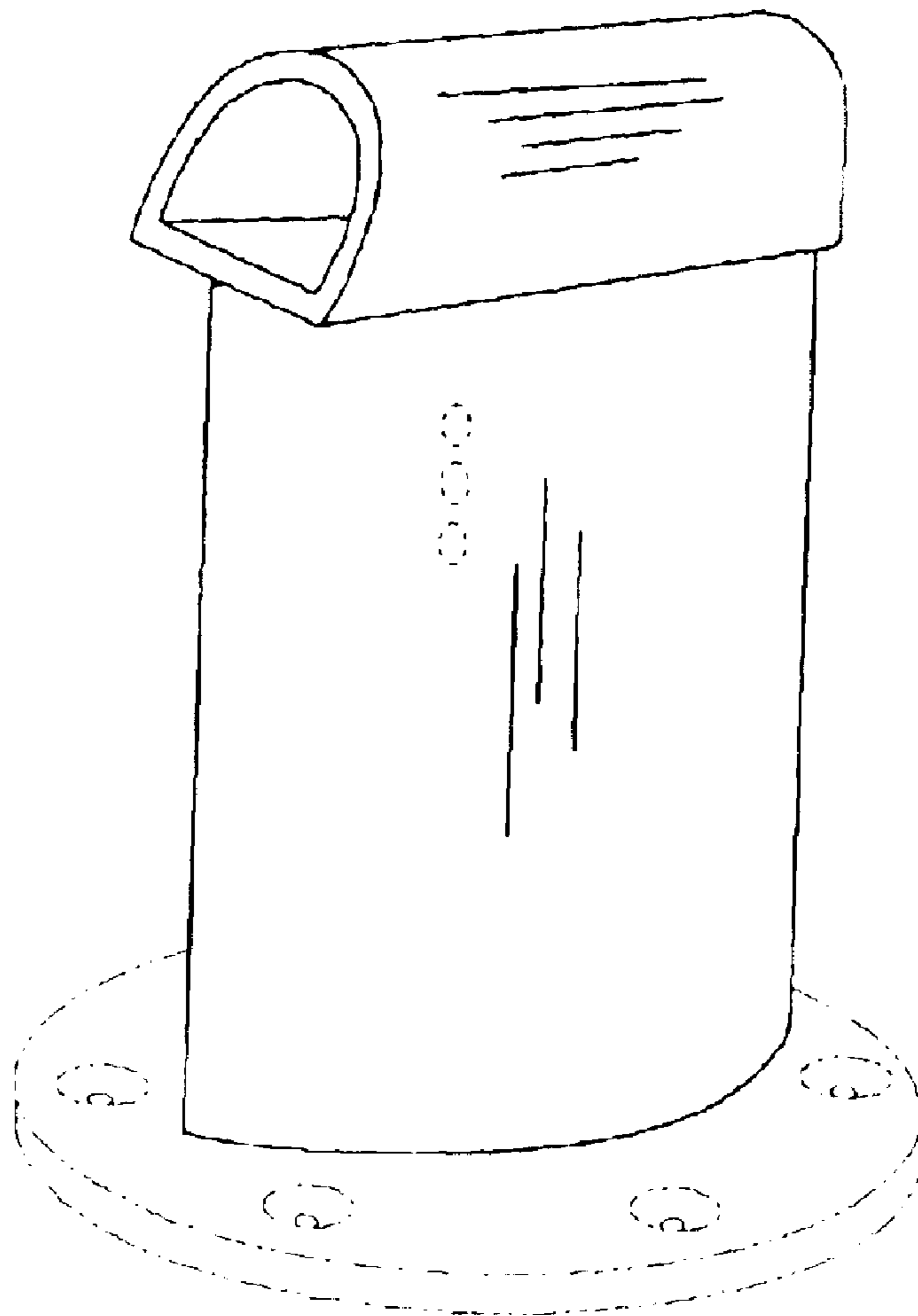

FIG. 16

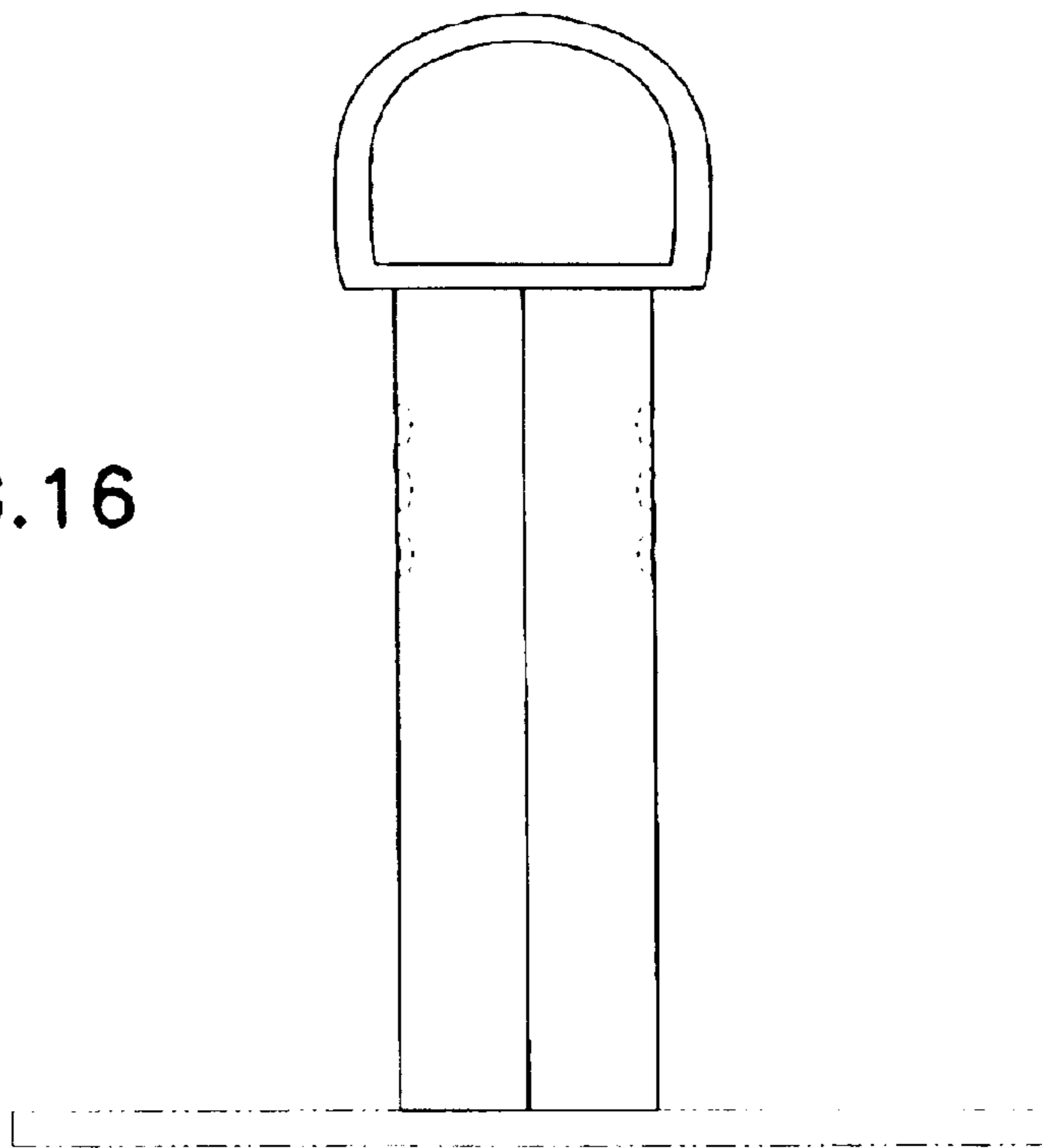

FIG. 17

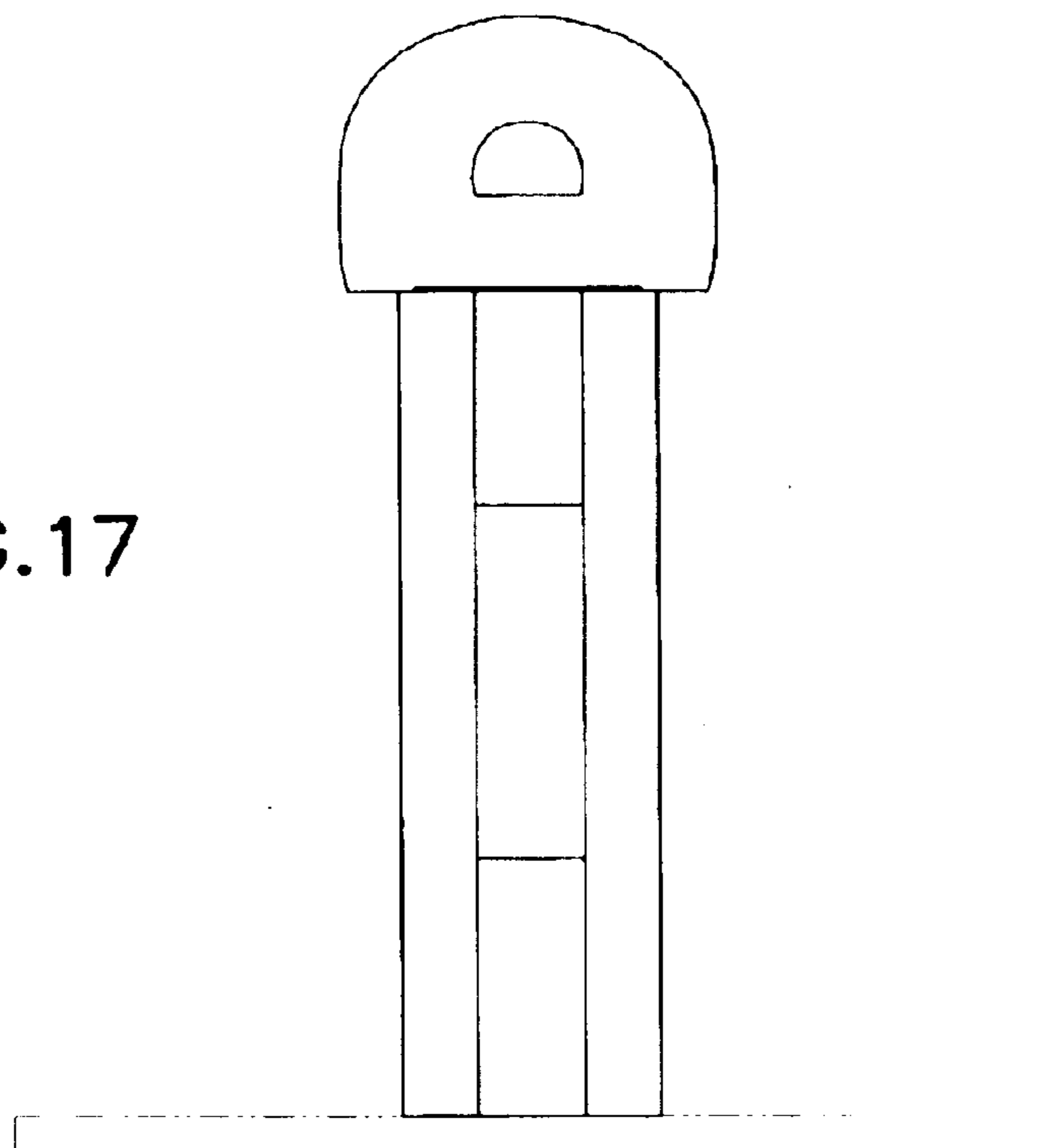

FIG.18

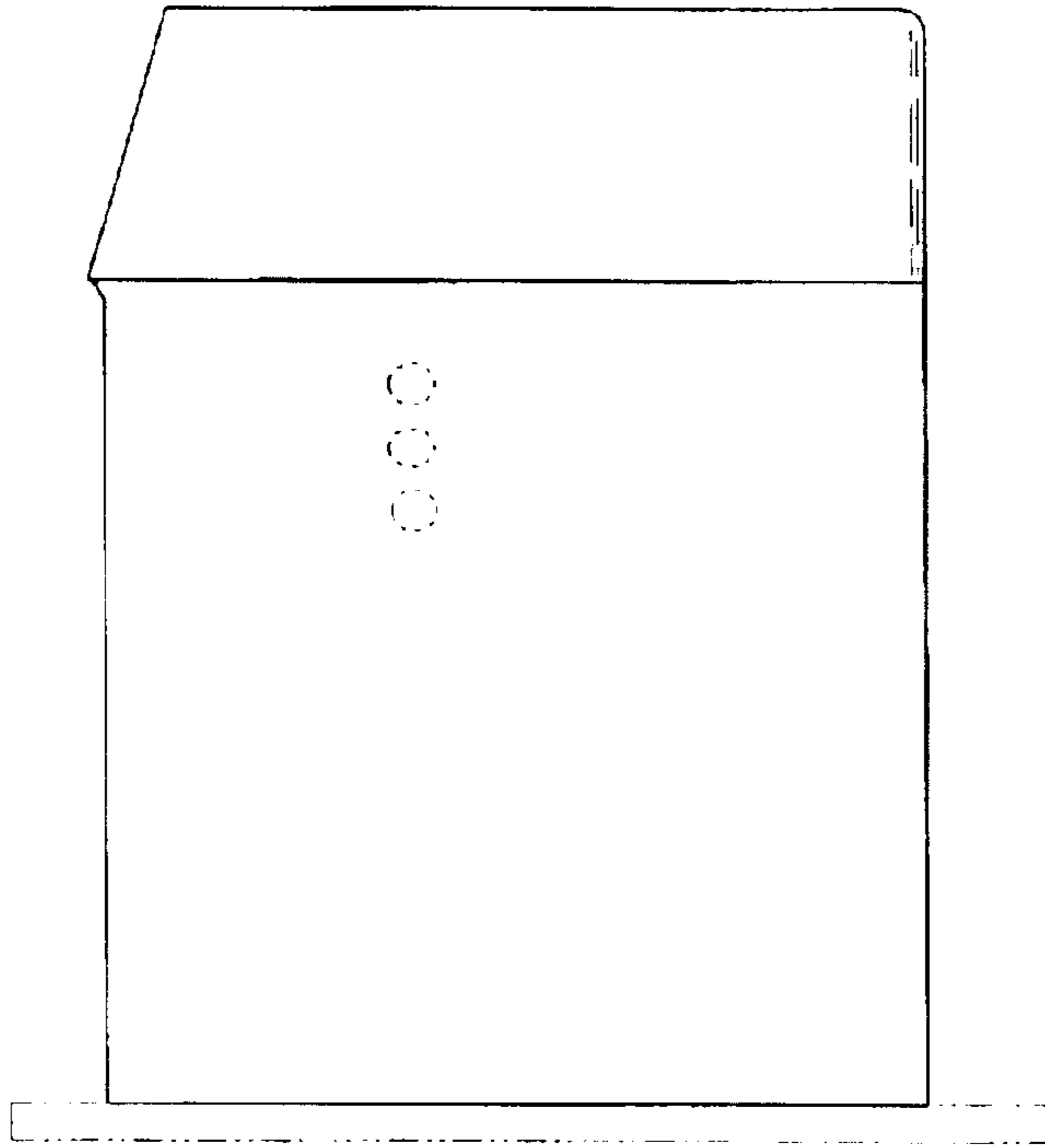

FIG.19

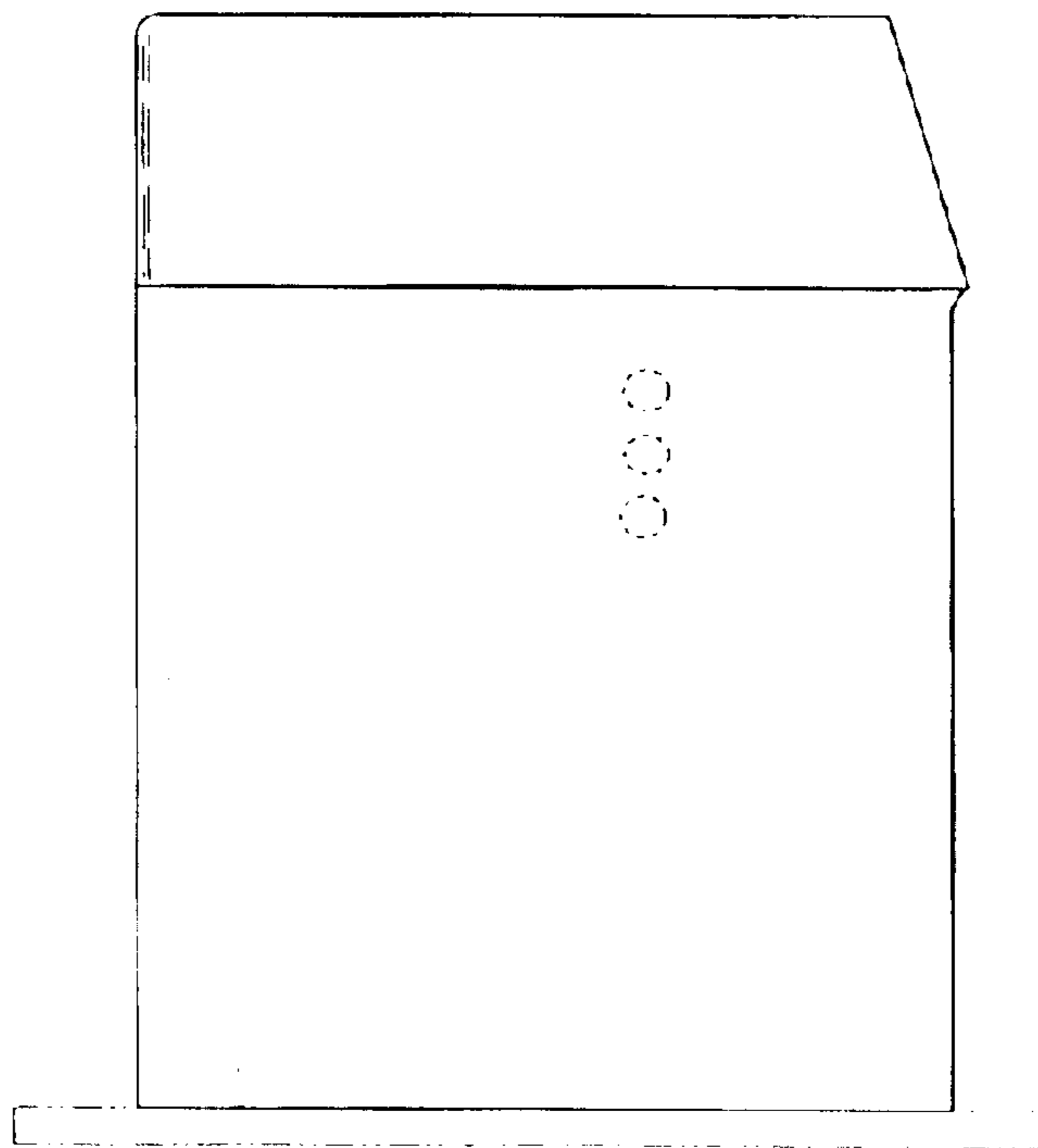

FIG.20

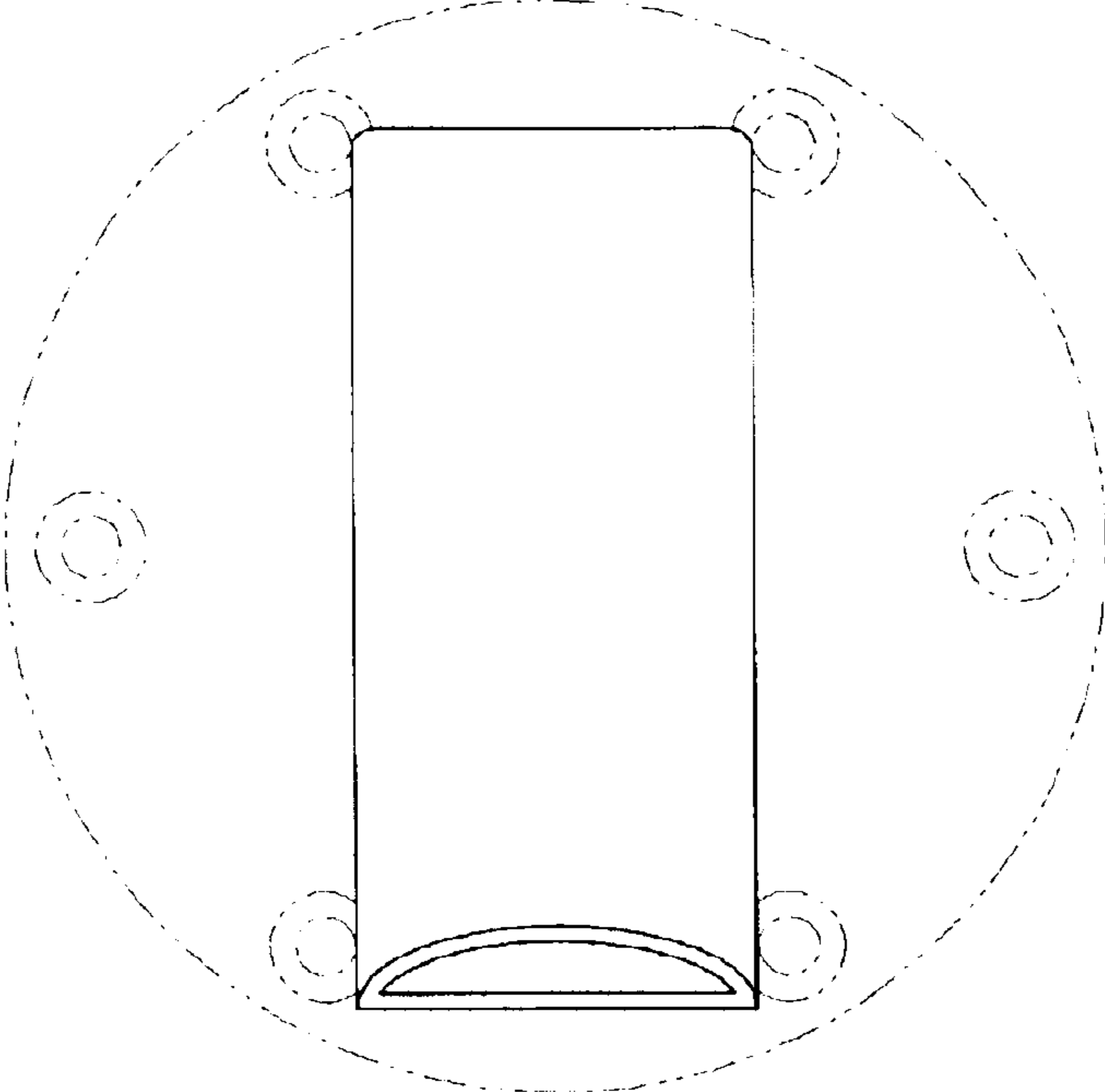

FIG.21

