

US00D497089S1

(12) **United States Design Patent**  
**Huebner et al.**

(10) **Patent No.: US D497,089 S**  
(45) **Date of Patent: \*\* Oct. 12, 2004**

- (54) **PORTABLE CRIMPING DEVICE**
- (75) Inventors: **Kenneth L. Huebner**, Mantua, OH (US); **Thomas B. Lininger**, Mantua, OH (US); **Benjamin M. Trace**, Mogadore, OH (US)
- (73) Assignee: **Parker-Hannifin Corporation**, Cleveland, OH (US)
- (\*\*) Term: **14 Years**
- (21) Appl. No.: **29/162,878**
- (22) Filed: **Jun. 20, 2002**
- (51) **LOC (7) Cl. .... 08-05**
- (52) **U.S. Cl. .... D8/51**
- (58) **Field of Search .... D8/51, 59, 60; D15/122, 123; 72/402, 416, 446, 454; 100/257; 29/237, 335, 247, 282, 283.5**

- 4,331,019 A \* 5/1982 Smith ..... 72/402
- 4,515,006 A \* 5/1985 Stanley ..... 72/402
- D280,201 S \* 8/1985 Moreiras et al. .... D15/123
- D288,327 S \* 2/1987 Proctor et al. .... D15/123
- 4,862,725 A \* 9/1989 Stiver et al. .... 72/402
- 5,056,351 A \* 10/1991 Stiver et al. .... 72/402
- 5,297,417 A \* 3/1994 Orcutt et al. .... 72/402

\* cited by examiner

*Primary Examiner*—Clare E Heflin

(74) *Attorney, Agent, or Firm*—Joseph J. Pophal

(57) **CLAIM**

The ornamental design for a portable crimping device, as shown and described.

**DESCRIPTION**

FIG. 1 is a front, elevational view of a portable crimping device embodying our new design.  
 FIG. 2 is a rear, elevational view.  
 FIG. 3 is a left, elevational view.  
 FIG. 4 is a right, elevational view.  
 FIG. 5 is a top, plan view.  
 FIG. 6 is a bottom, plan view; and,  
 FIG. 7 is a front perspective view.

(56) **References Cited**  
**U.S. PATENT DOCUMENTS**

- 3,568,494 A \* 3/1971 Geisman ..... 72/402
- 3,858,298 A \* 1/1975 Whitledge et al. .... 29/237
- 4,244,091 A \* 1/1981 Kimble et al. .... 29/237

**1 Claim, 6 Drawing Sheets**

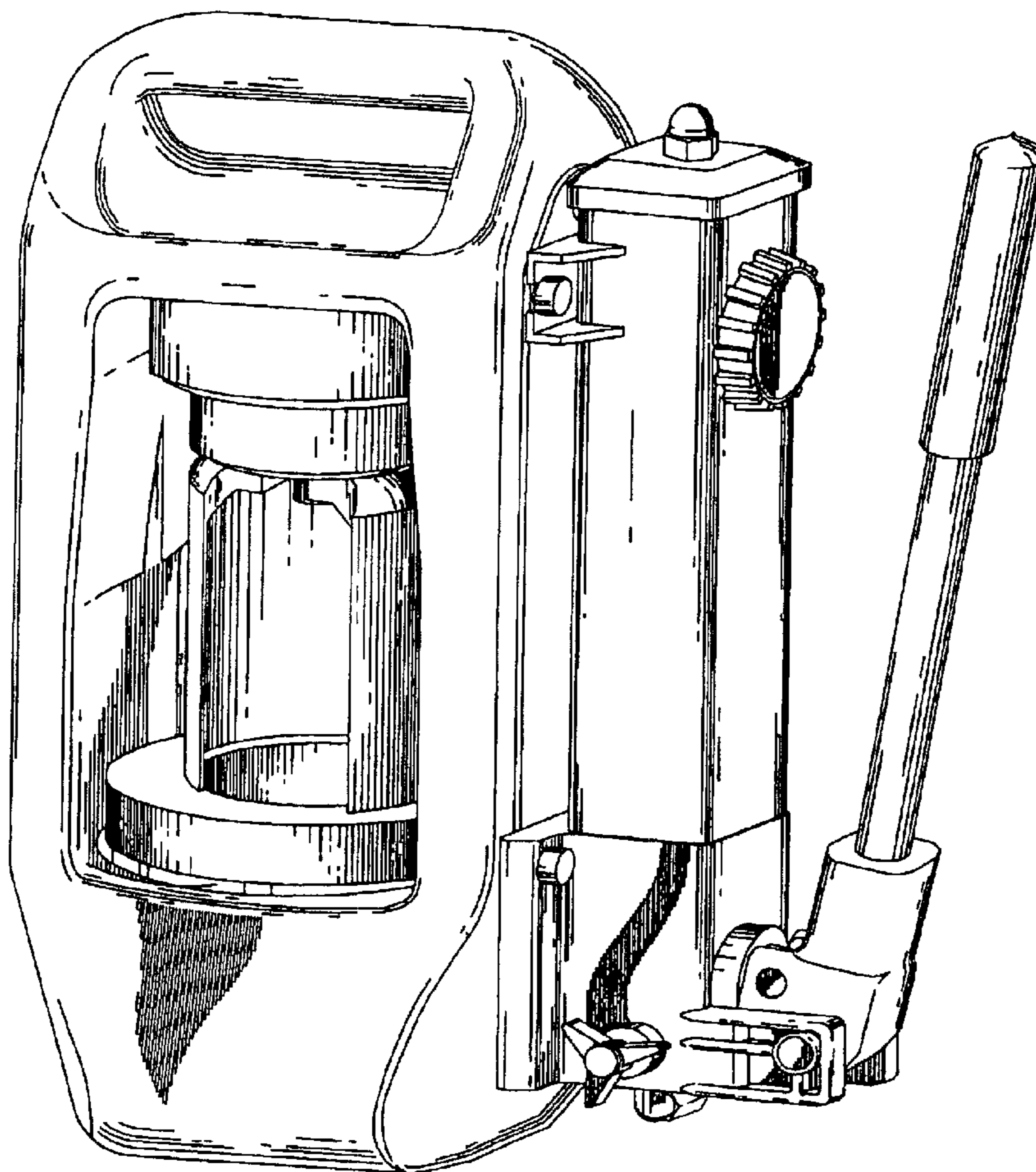

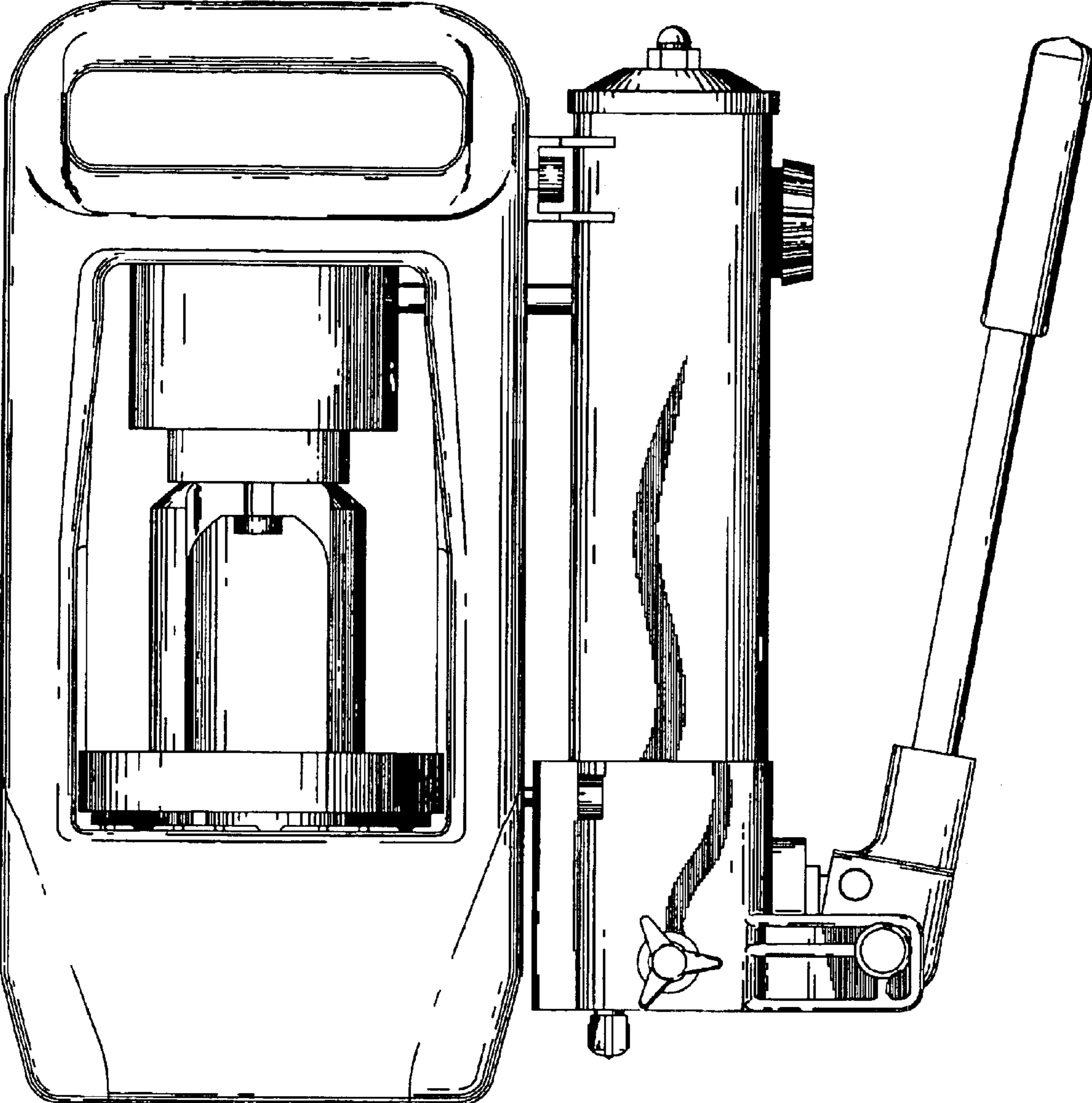

Fig. 1

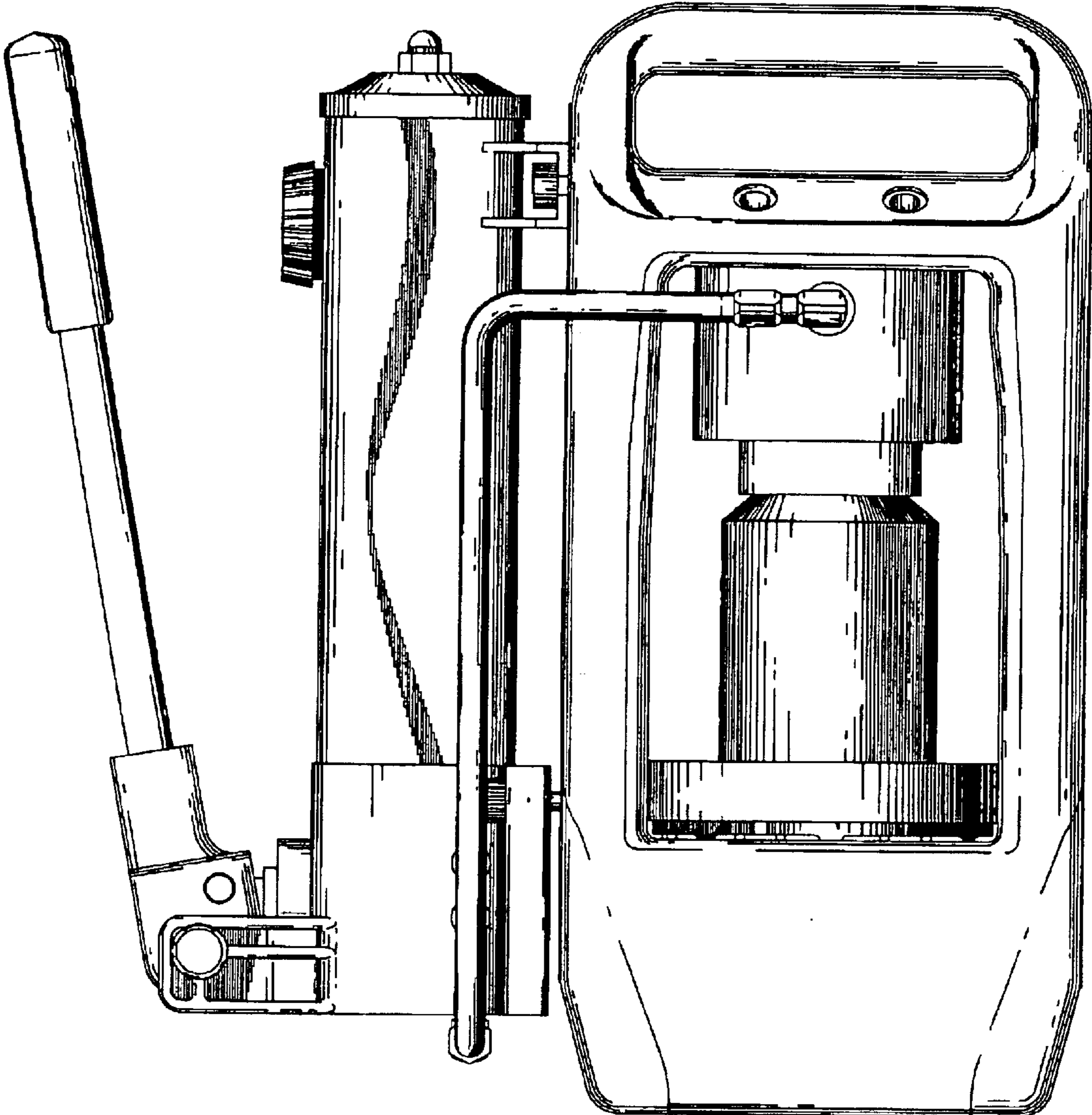

Fig. 2

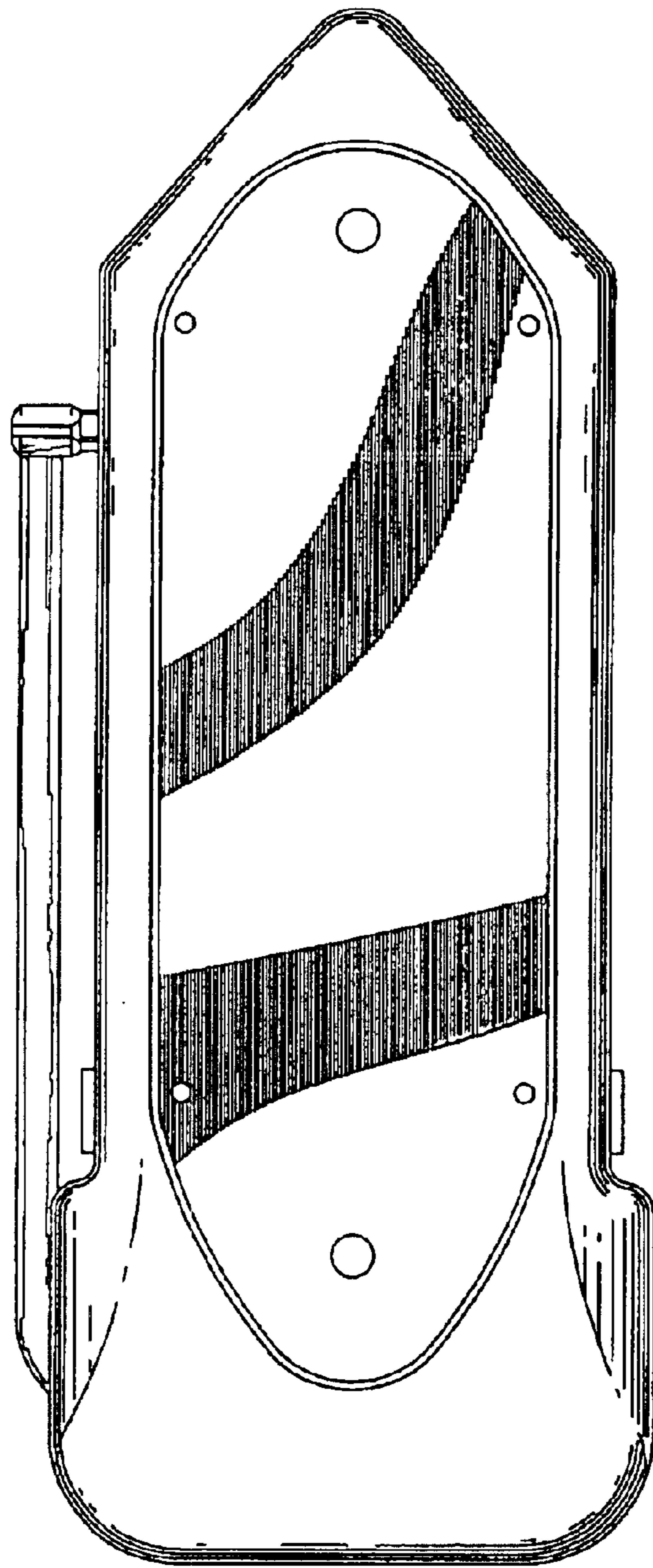

Fig. 3

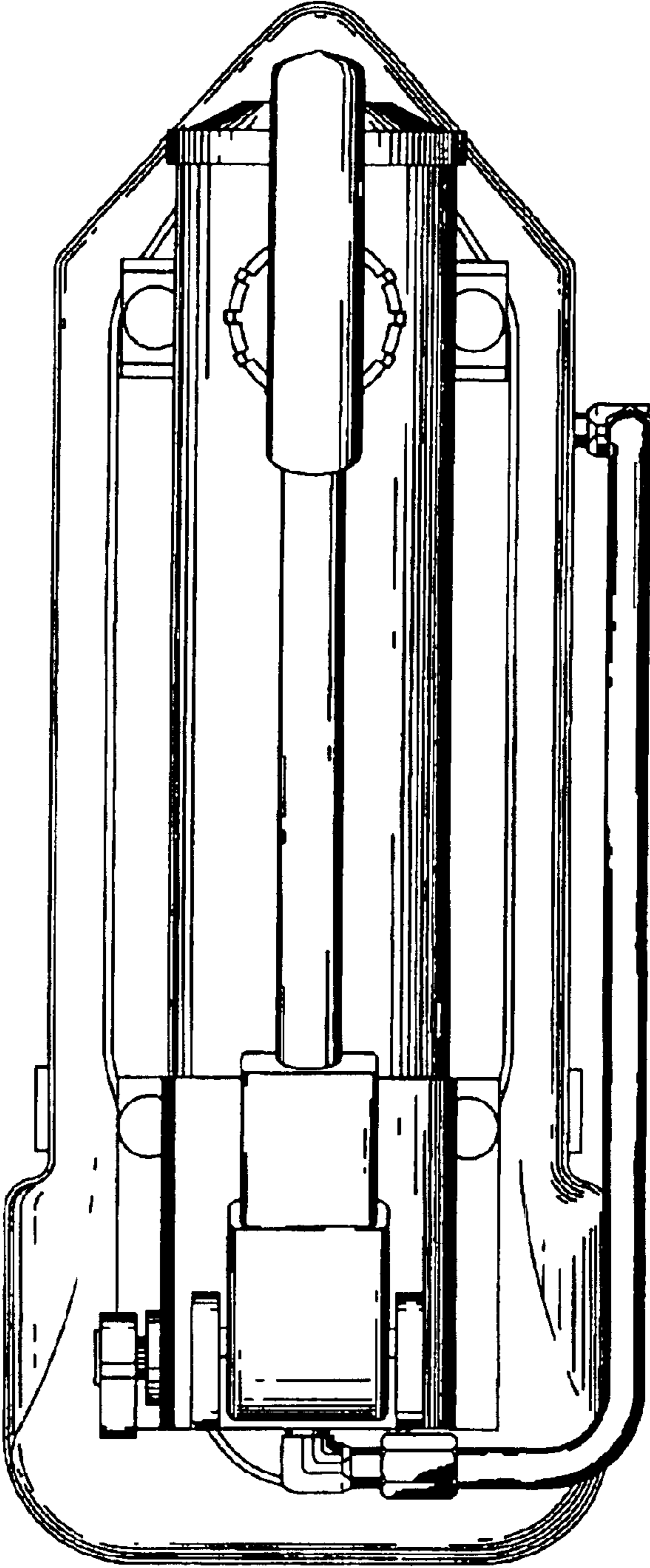

Fig. 4

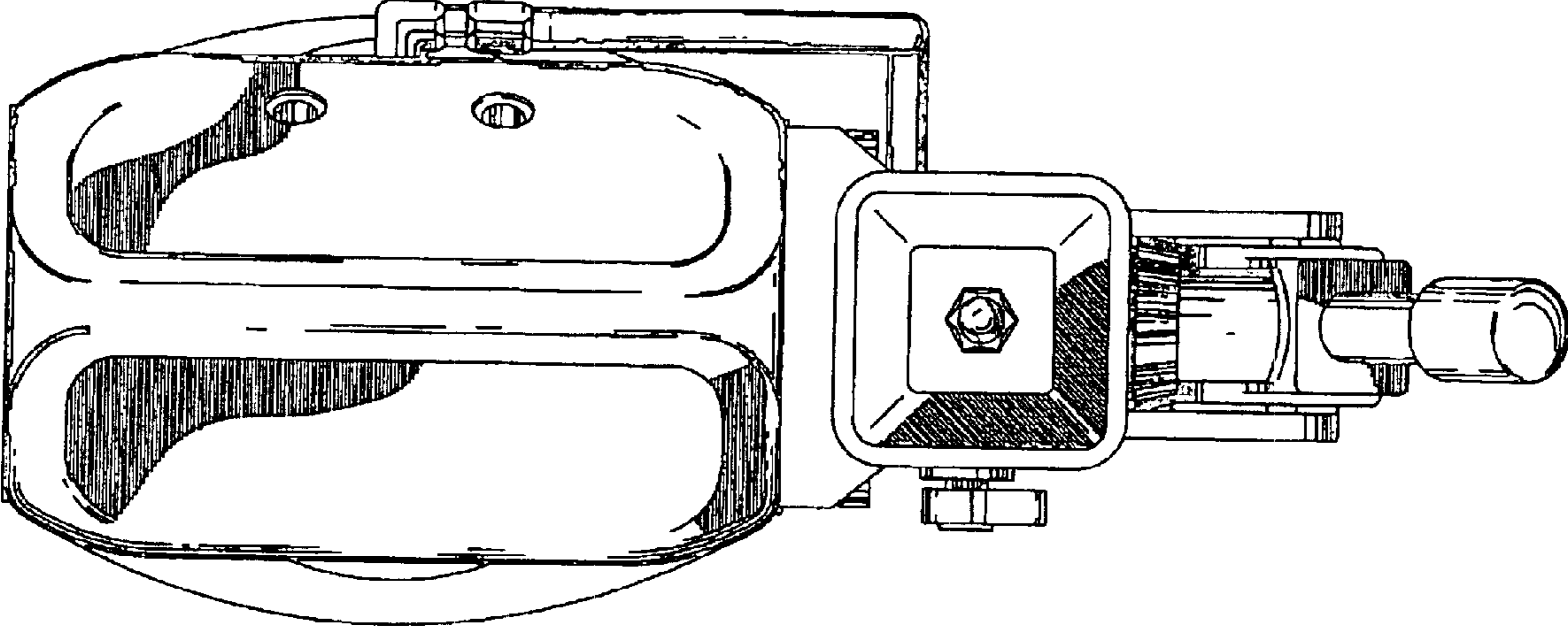

Fig. 5

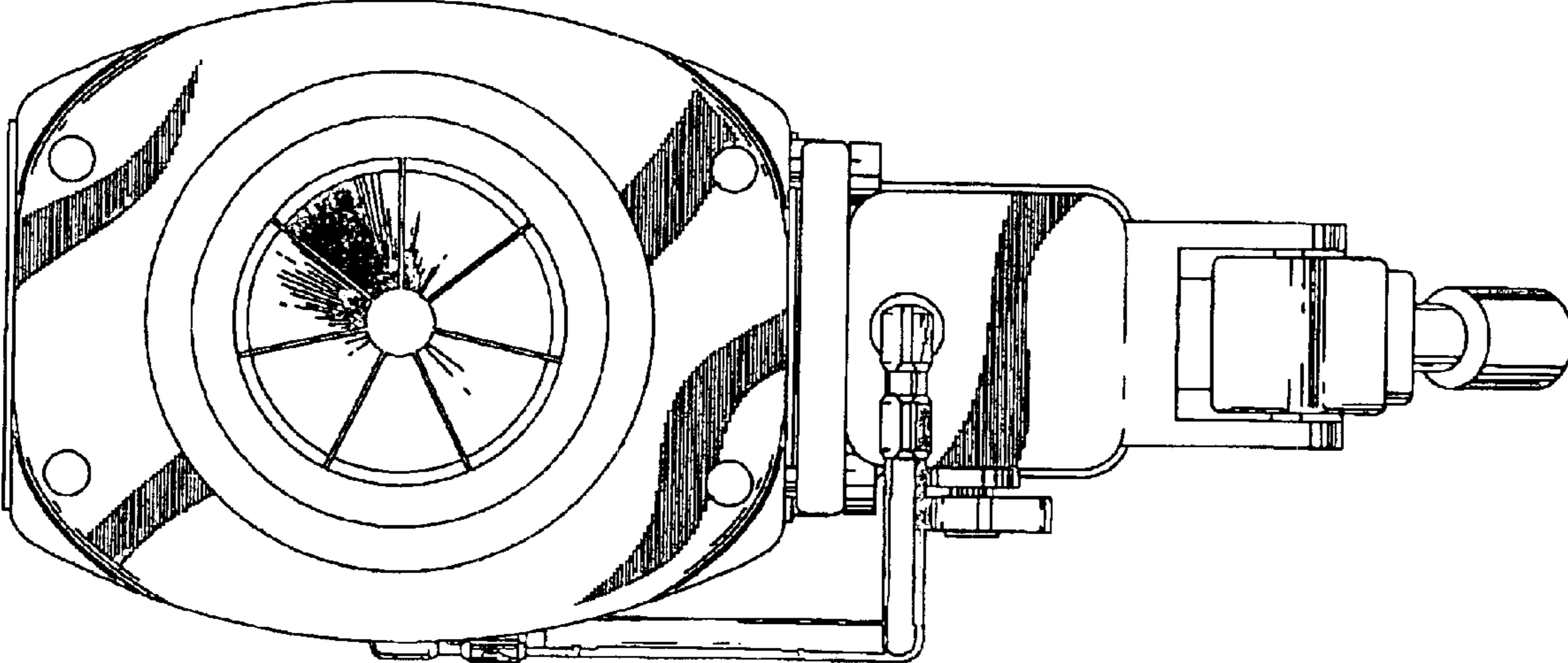

Fig. 6

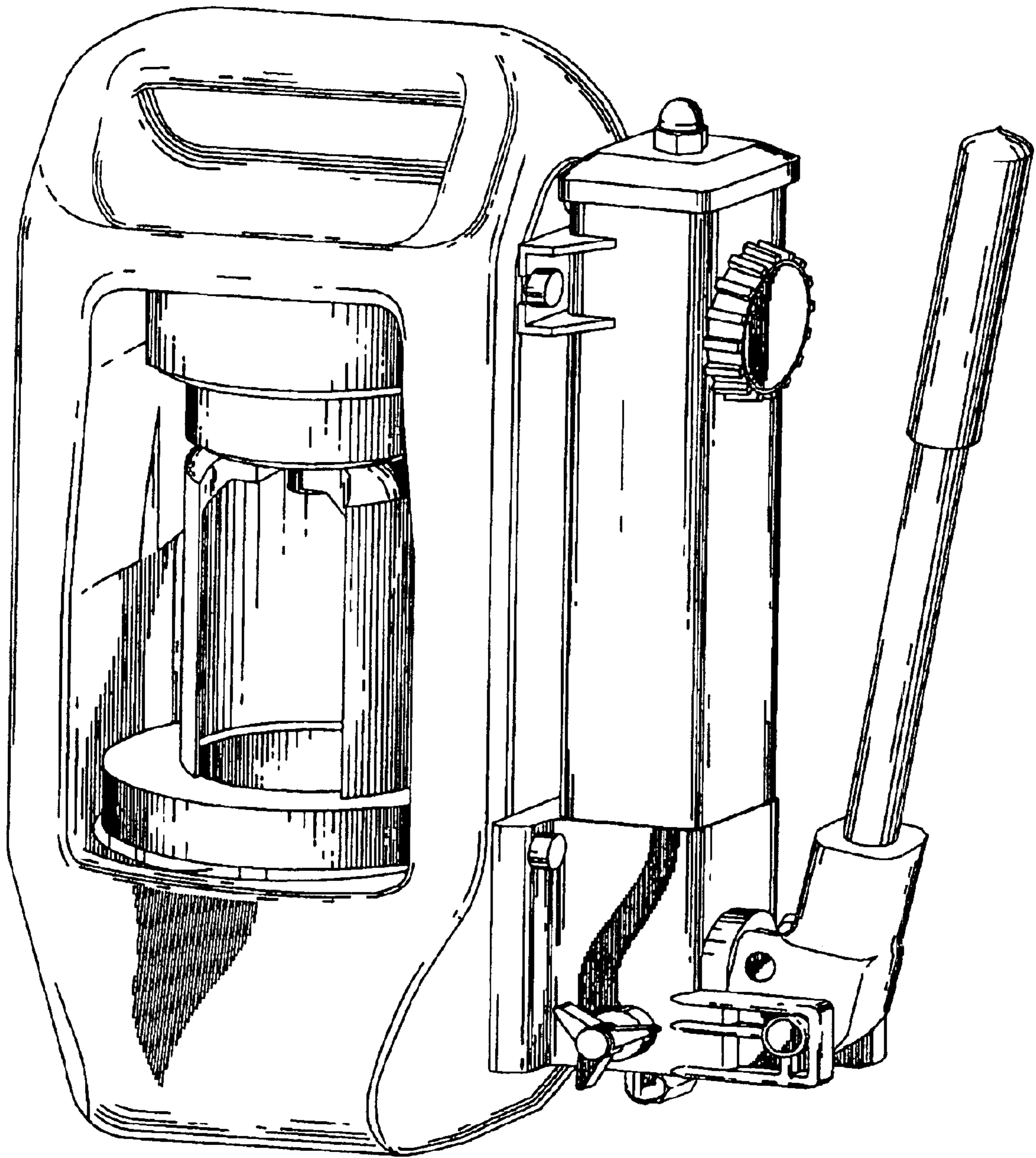

Fig. 7