

US00D497005S1

(12) **United States Design Patent** (10) **Patent No.:** **US D497,005 S**  
**Zimmerlee** (45) **Date of Patent:** **\*\* Oct. 5, 2004**

(54) **PIER SYSTEM**

(76) Inventor: **James D. Zimmerlee**, 825 Miller Dr., Oregon, WI (US) 53575

(\*\*) Term: **14 Years**

(21) Appl. No.: **29/191,257**

(22) Filed: **Oct. 3, 2003**

(51) **LOC (7) Cl.** ..... **25-03**

(52) **U.S. Cl.** ..... **D25/1**

(58) **Field of Search** ..... D25/1; D21/506, D21/483; 405/4, 1, 231

Zahn, F.A.; Fontana, M., Innovative Composite Construction, Schweiz, Ing. Archit., Jun. 15, 1995, pp. 4–11, Jauslin & Stabler Ingenisur; ETH Honggerberg, Switzerland.

No Author, Body Structure Thing, Titaniumcrud Light Steel Board, The First Adoption, Zairyo To Kankyo, Jul. 15, 1999, p. 457, vol. 48 No. 7, Japan.

Yamaguchi, Y.; Tomita, M.; Nishida, T.; Sakai, M., Design of the Okuyama Bridge, Puresutoresuto Konku, Mar. 31, 1997, pp. 85–92, vol. 39 No. 2, Hanshin Expressway Pub, Japan.

Altabba, Bashar, Re-creating the Rainbow Bridge, Civil Engineering, 2000, pp. 32–37, vol. 70 No. 5, HNTB, Boston, MA.

(List continued on next page.)

(56) **References Cited**

**U.S. PATENT DOCUMENTS**

3,011,467	A	*	12/1961	Letourneau	.....	114/265
4,282,619	A		8/1981	Rooney		
4,309,125	A		1/1982	Richardson		
4,450,121	A		5/1984	Bequette		
4,646,379	A		3/1987	Muller		
5,048,640	A		9/1991	McConville et al.		
5,570,486	A		11/1996	Wiedeck		
5,755,981	A		5/1998	Payne		
6,170,105	B1		1/2001	Doyle et al.		
6,381,793	B2		5/2002	Doyle et al.		
6,449,791	B1		9/2002	Vodicka		
6,663,322	B1	*	12/2003	Listle	.....	405/239

**FOREIGN PATENT DOCUMENTS**

EP	00164936	B1	4/1992
EP	00420065		10/2000
JP	07191118		1/1997
JP	07197858		1/1997
JP	08043180		9/1997
JP	9-281269	A	10/1997
JP	10147006		12/1999
JP	10320353		5/2000

**OTHER PUBLICATIONS**

Jacobs, G.W., Improvement of the Suspension Monorail in Wuppertal Germany, Praktiker, Sep. 2002, pp. 316–318, Germany.

*Primary Examiner*—Doris Clark

(74) *Attorney, Agent, or Firm*—Godfrey & Kahn, S.C.; Sonali S. Srivastava

(57) **CLAIM**

The ornamental design of a pier system, as shown and described.

**DESCRIPTION**

FIG. 1 is a perspective view of a pier system according to a preferred embodiment of the invention.

FIG. 2 is a top plan view of the pier system shown in FIG. 1;

FIG. 3 is a side elevational view of the pier system shown in FIG. 1;

FIG. 4 is a rear end view of the pier system shown in FIG. 1 as viewed from a water front end;

FIG. 5 is a front end view of the pier system shown in FIG. 1 as viewed from a ground end; and,

FIG. 6 is a bottom plan view of the pier system shown in FIG. 1.

The posts and gangway have been fragmented for convenience of illustration.

**1 Claim, 5 Drawing Sheets**

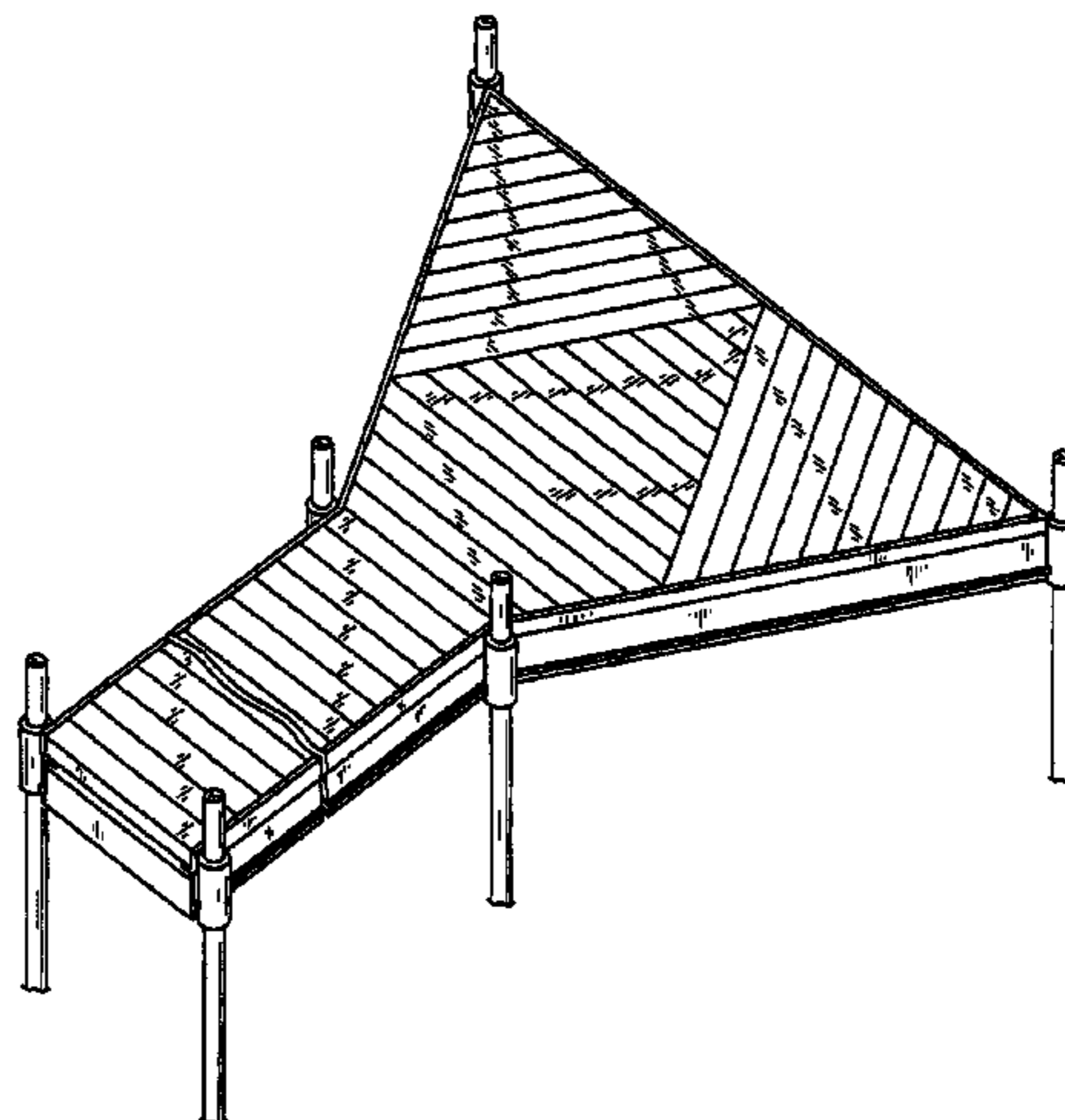

OTHER PUBLICATIONS

Milkovich, Scott; Harik, Issam E.; Brailsford, Bruce, Composite Materials for Bridges, Construction Specifier, May 1996, pp. 102–106, vol. 49 No. 5, USA.

Gudmestad, O.T.; Warland, T.A., Optimum Use of Concrete Structures et al., Proc. Int. Meet. Pet. Eng., 1992, pp. 457–470, Soc. of Petroleum Engineers of AIME, Richardson, TX.

Anon, Prestressed Concrete Beams for the New Teifi Bridge. Concrete Plant and Production, May 1991, pp. 175–176.

No Author, Building Tougher Bridges, Metal Bulletin Monthly, Aug. 2002, p. 61, United Kingdom.

Black, S., A Survey of Composite Bridges, Composites Technology, Mar.–Apr. 2000, pp. 14–18, USA.

No Author, Composite Bridge Construction Increases, Adv. Compos. Bull., Mar. 1995, pp. 6–7, United Kingdom.

No Author, Composite Road Bridge, Adv. Comp. Bulletin, Sep. 1997, p. 8, United Kingdom.

\* cited by examiner

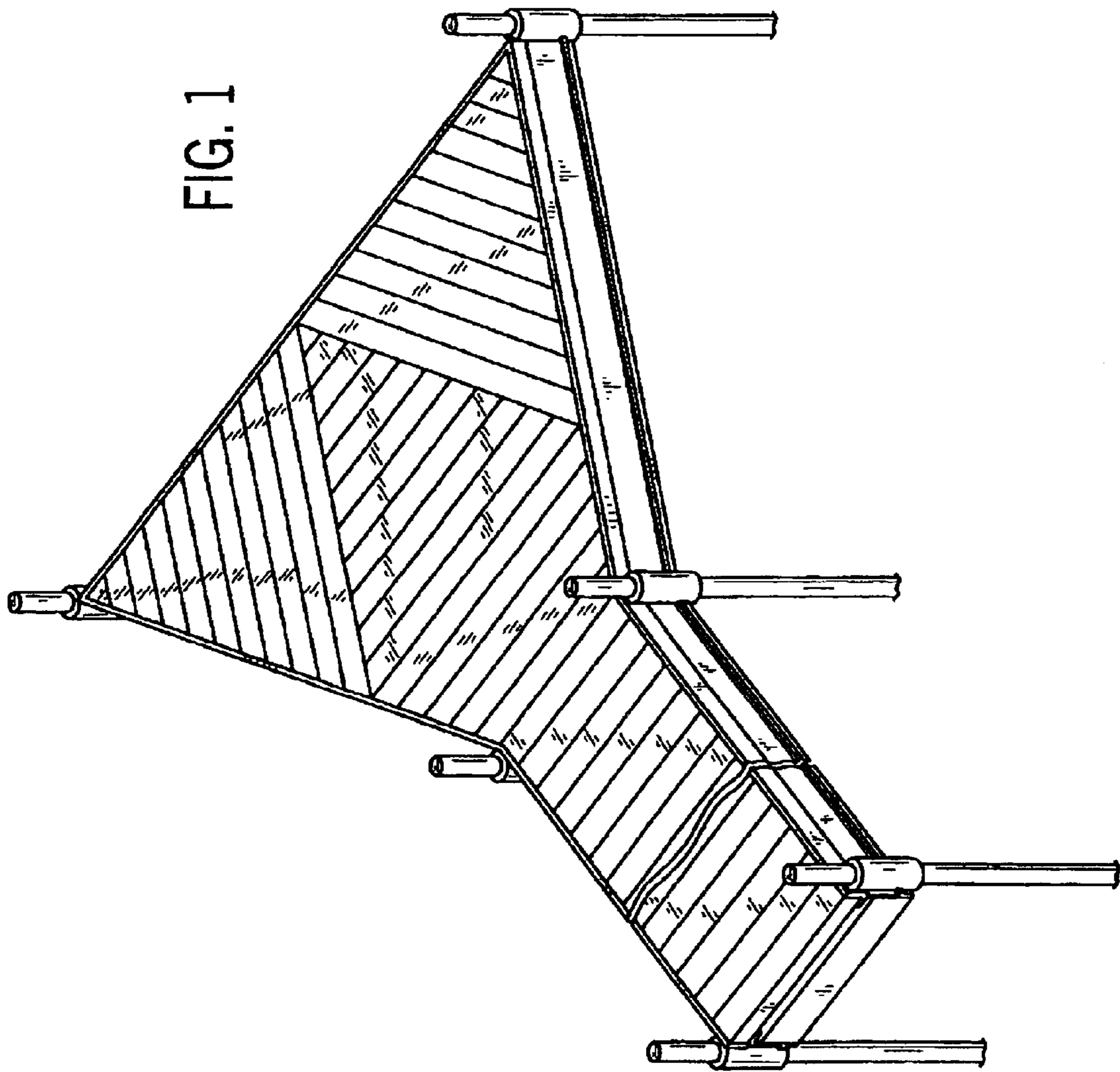
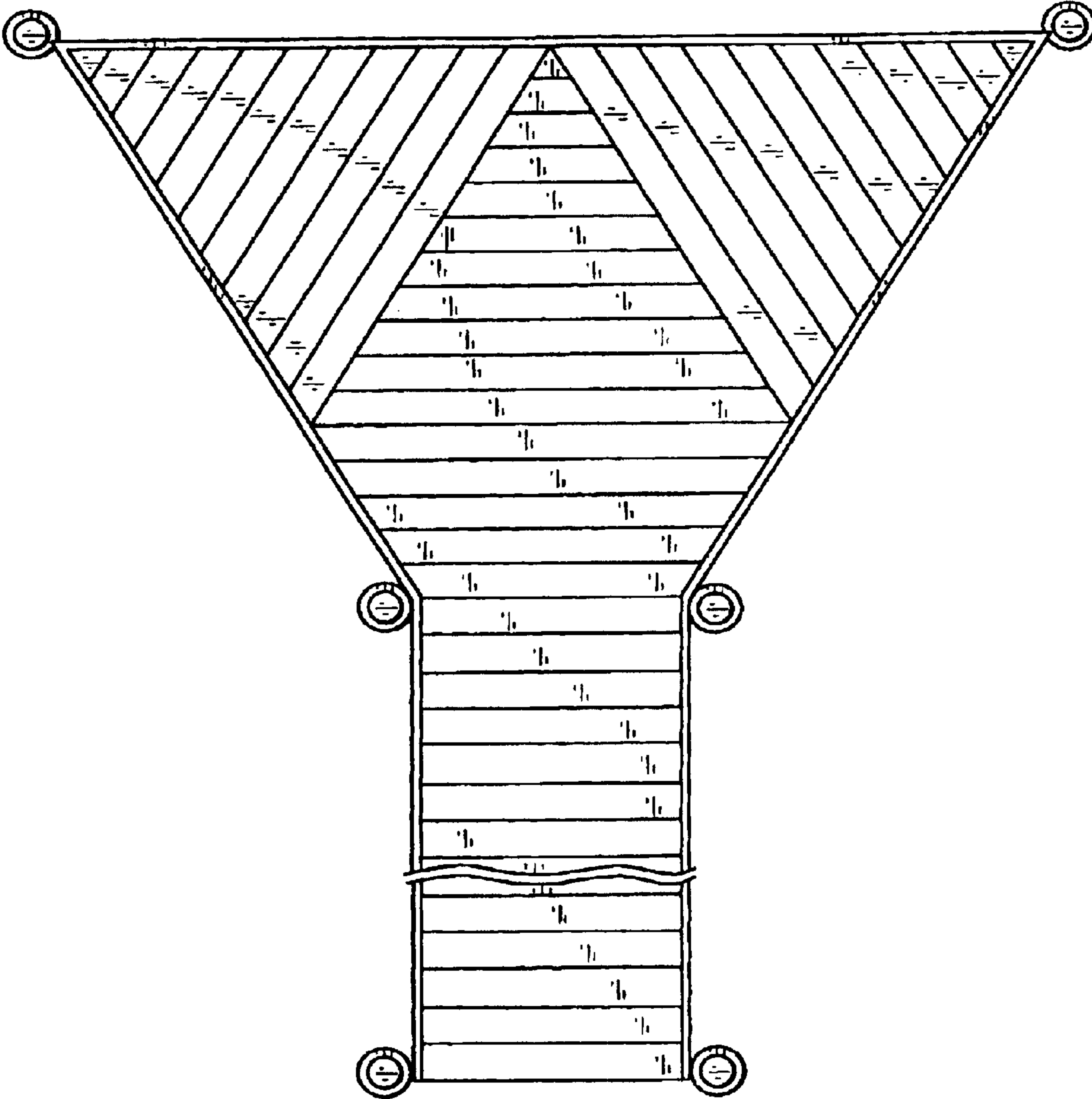

FIG. 1

FIG. 2



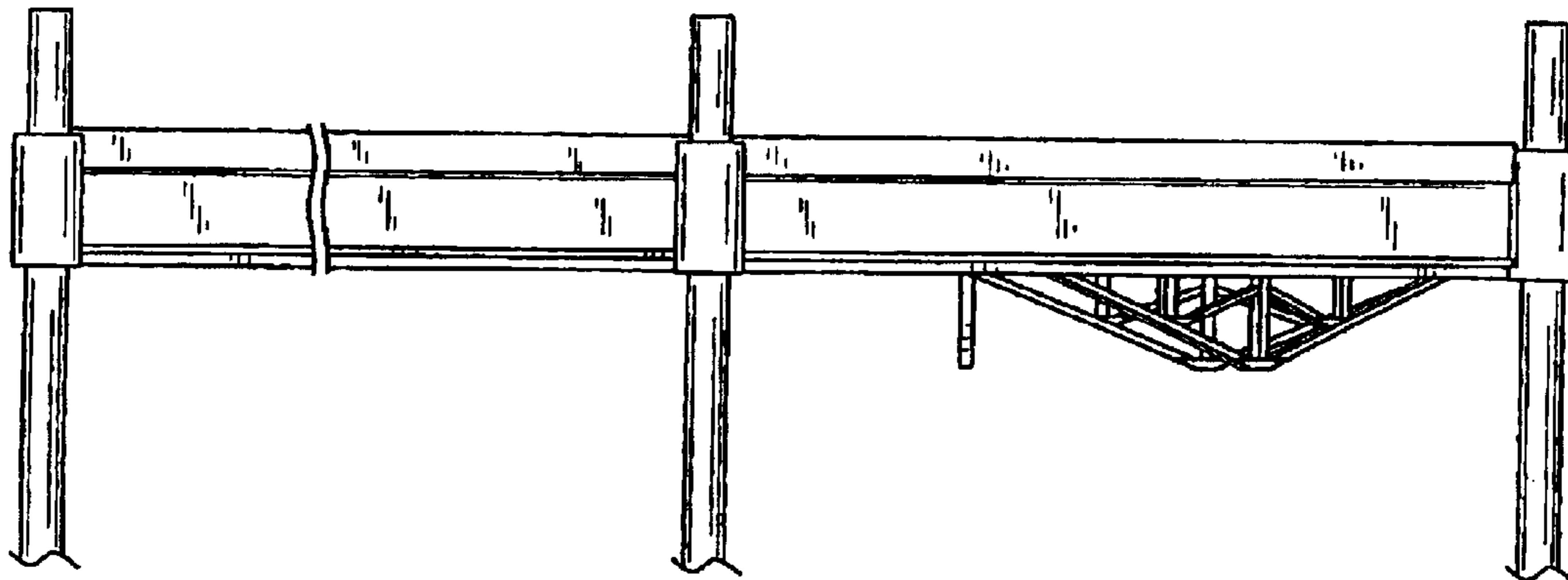

FIG. 3

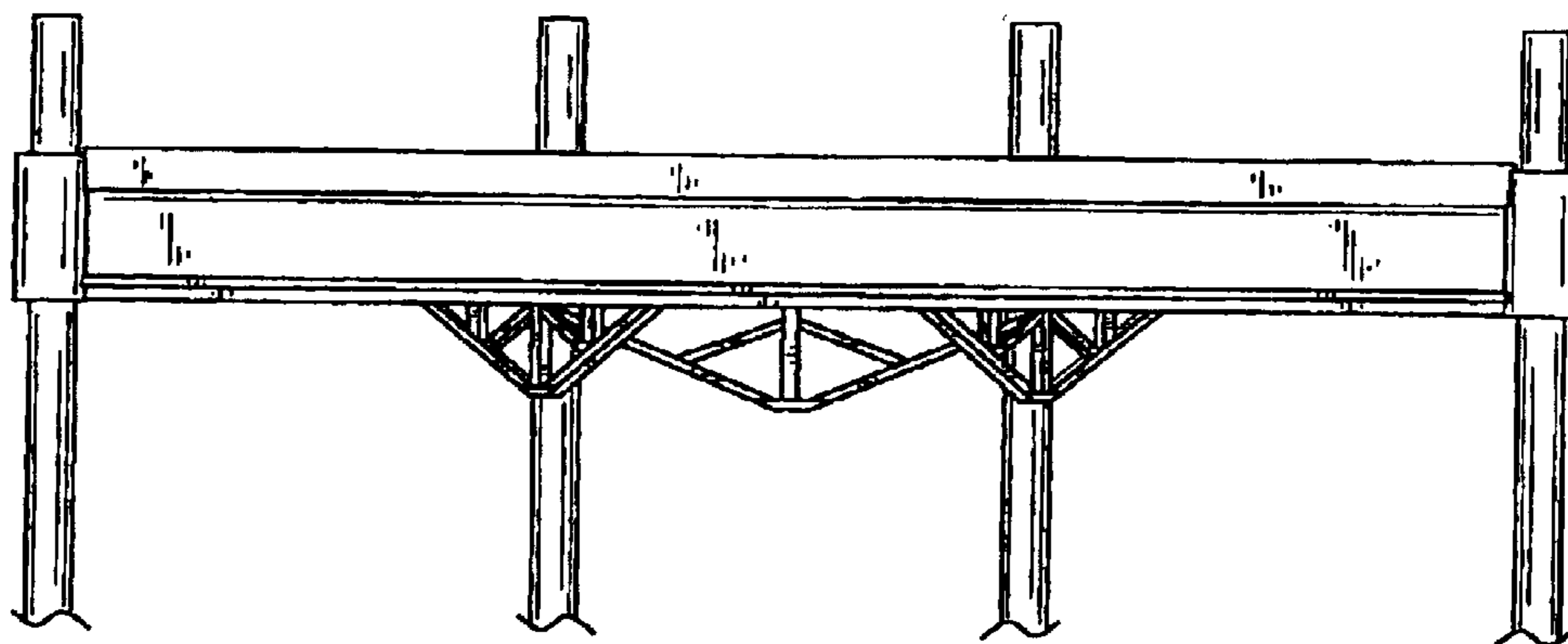

FIG. 4

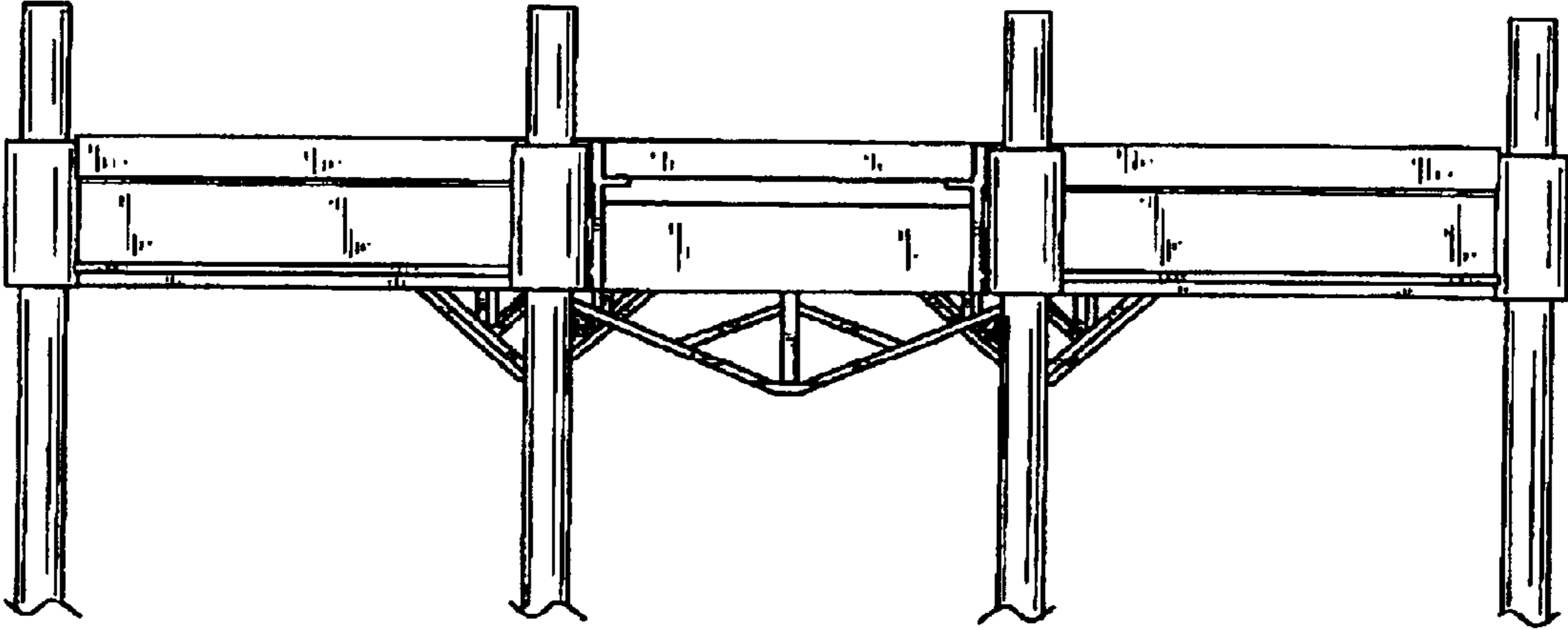

FIG. 5

FIG. 6

