

US00D496763S1

(12) **United States Design Patent** (10) **Patent No.:** **US D496,763 S**  
**Chen** (45) **Date of Patent:** **\*\* Sep. 28, 2004**

(54) **HIGH PRESSURE CLEANER**  
 (76) **Inventor:** **Jiming Chen**, 190 Industry Rd., Jinring Town, Luqiao Area, Taizhou, Zhejiang Province 318058 (CN)

(\*\*) **Term:** **14 Years**

(21) **Appl. No.:** **29/177,720**

(22) **Filed:** **Mar. 17, 2003**

(51) **LOC (7) Cl.** ..... **15-05**

(52) **U.S. Cl.** ..... **D32/16**

(58) **Field of Search** ..... D32/15-16, 21-22, D32/31; 15/320-321, 323, 347, 350, 352-535, 49.1, 79.1-79.2

D420,473 S \* 2/2000 Shero ..... D32/16  
 D422,386 S \* 4/2000 Jaros et al. .... D32/21  
 D446,612 S \* 8/2001 Kohler ..... D32/21  
 D458,423 S \* 6/2002 Rehkugler et al. .... D32/16  
 D463,888 S \* 10/2002 Rehkugler et al. .... D32/16  
 D464,471 S \* 10/2002 Burdsall et al. .... D32/15  
 D467,692 S \* 12/2002 Morgan et al. .... D32/15  
 D477,444 S \* 7/2003 Bisson ..... D32/21  
 D489,498 S \* 5/2004 Cattaneo ..... D32/15

\* cited by examiner

*Primary Examiner*—Ruth McInroy

(74) *Attorney, Agent, or Firm*—Birch, Stewart, Kolasch & Birch, LLP

(57) **CLAIM**

The ornamental design for a high pressure cleaner, as shown.

(56) **References Cited**

**U.S. PATENT DOCUMENTS**

D281,632 S \* 12/1985 Yang ..... D32/15  
 D318,543 S \* 7/1991 Shero ..... D32/23  
 D345,034 S \* 3/1994 Fitzwater ..... D32/21  
 D346,679 S \* 5/1994 Bradd et al. .... D32/22  
 D364,947 S \* 12/1995 Kent et al. .... D32/22  
 D375,590 S \* 11/1996 Steinhart et al. .... D32/15  
 D381,779 S \* 7/1997 Pritchett et al. .... D32/21  
 D394,526 S \* 5/1998 Strandell ..... D32/21  
 D404,859 S \* 1/1999 Dziersk et al. .... D32/21  
 5,901,410 A \* 5/1999 Windmeisser ..... 15/354

**DESCRIPTION**

FIG. 1 is a front elevational view of a high pressure cleaner showing my new design;  
 FIG. 2 is a right side elevational view thereof;  
 FIG. 3 is a left side elevational view thereof;  
 FIG. 4 is a bottom plan view thereof;  
 FIG. 5 is a top plan view thereof;  
 FIG. 6 is a rear elevational view thereof; and,  
 FIG. 7 is a perspective view thereof.

**1 Claim, 3 Drawing Sheets**

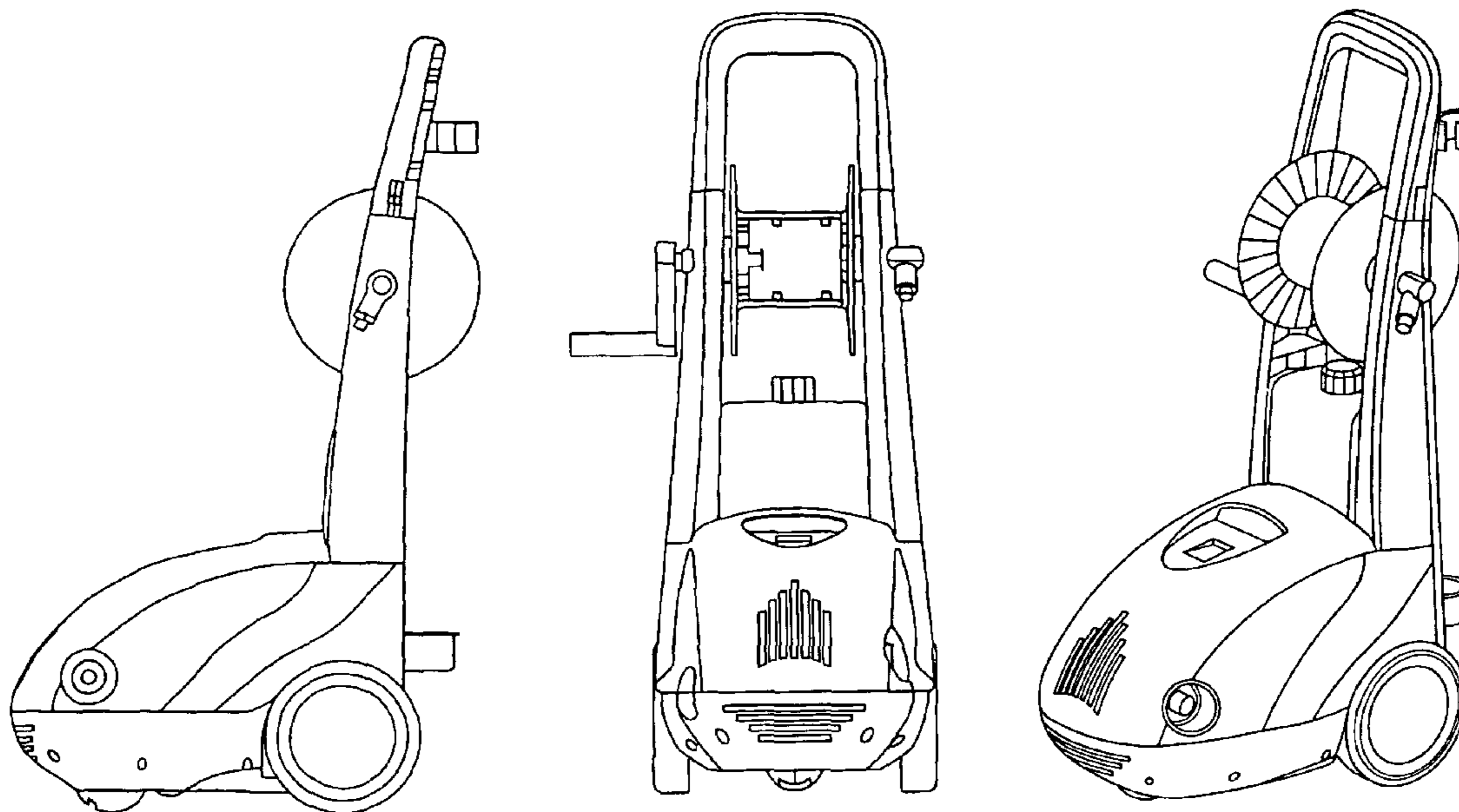

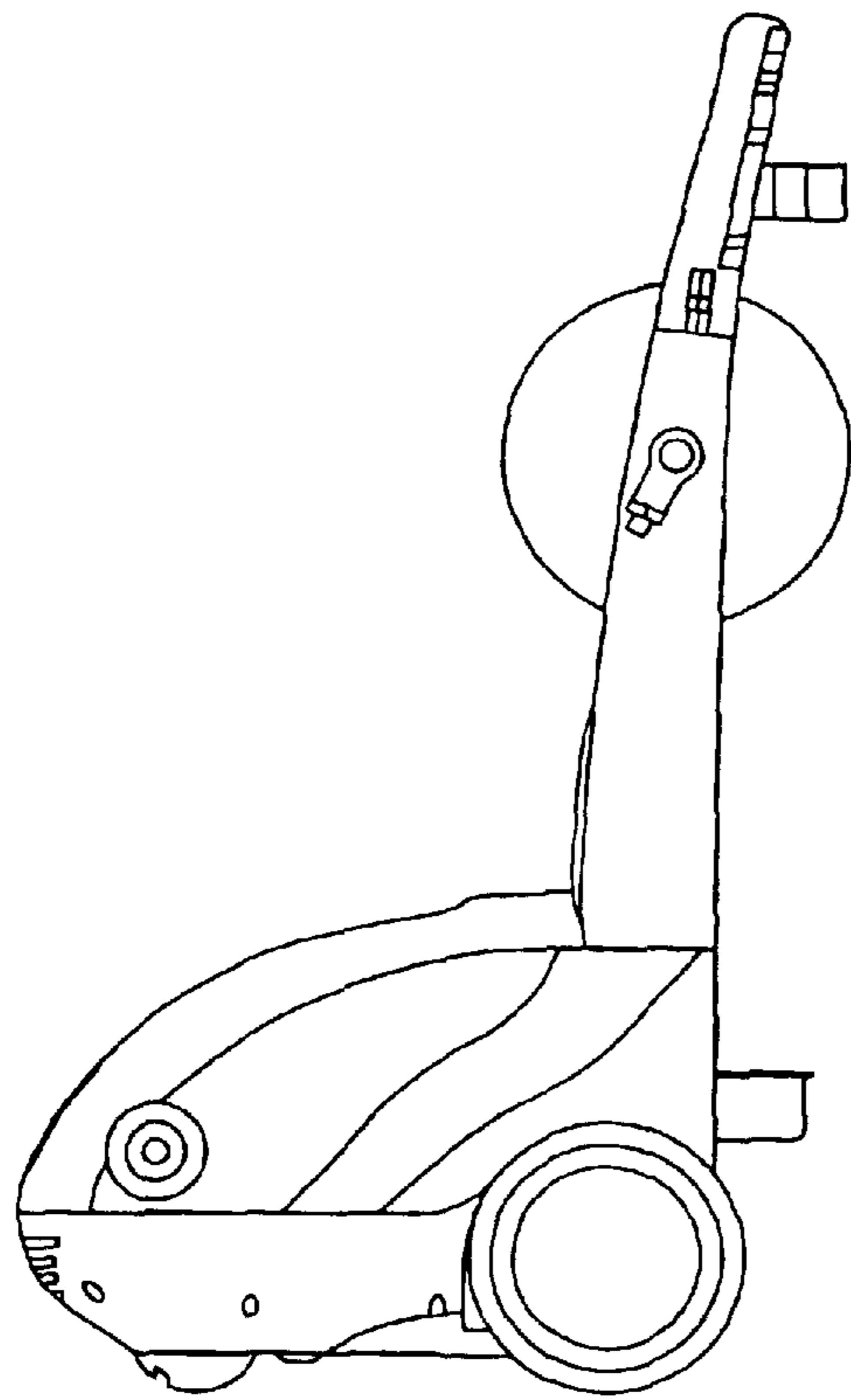

FIG. 1

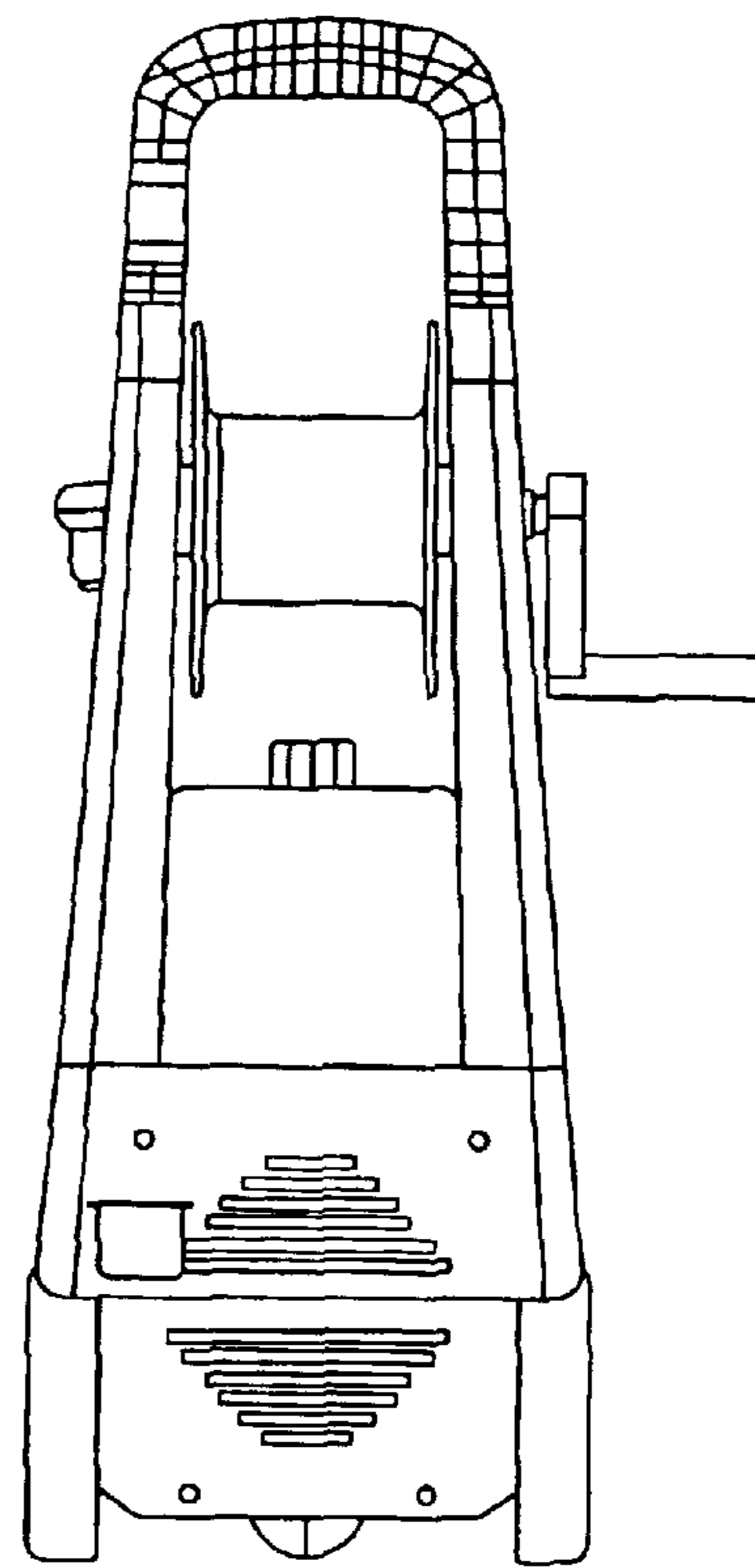

FIG. 2

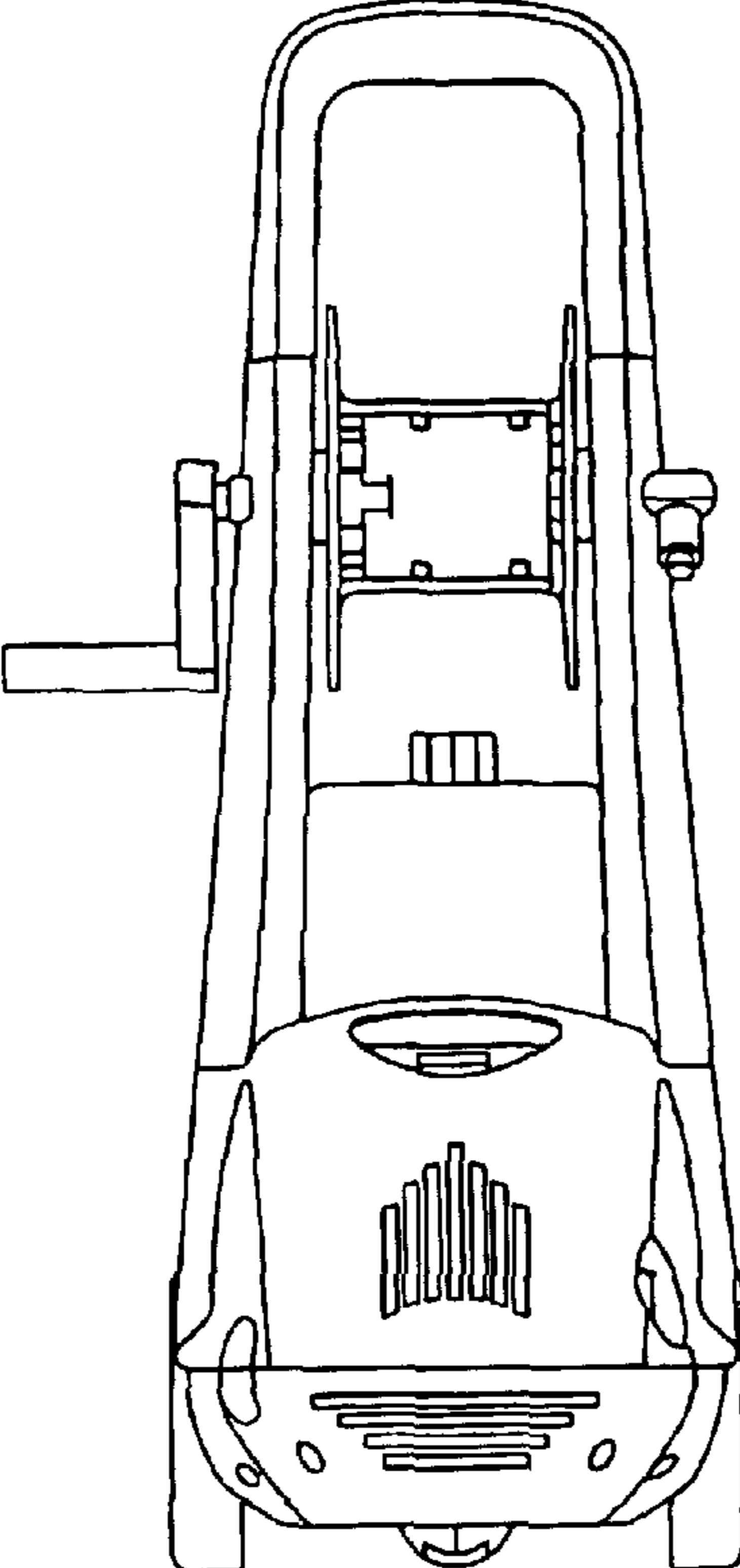

FIG.3

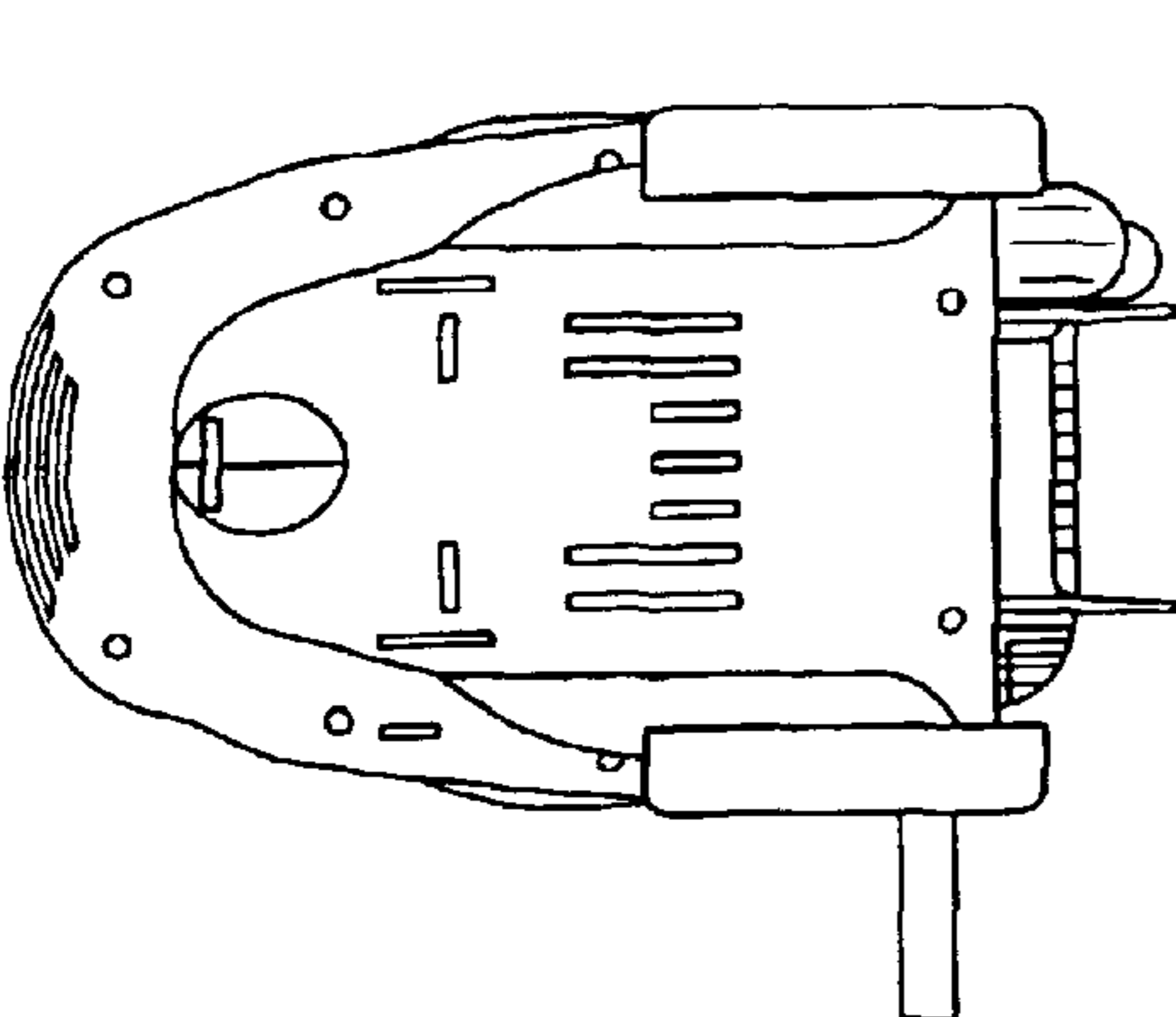

FIG.4

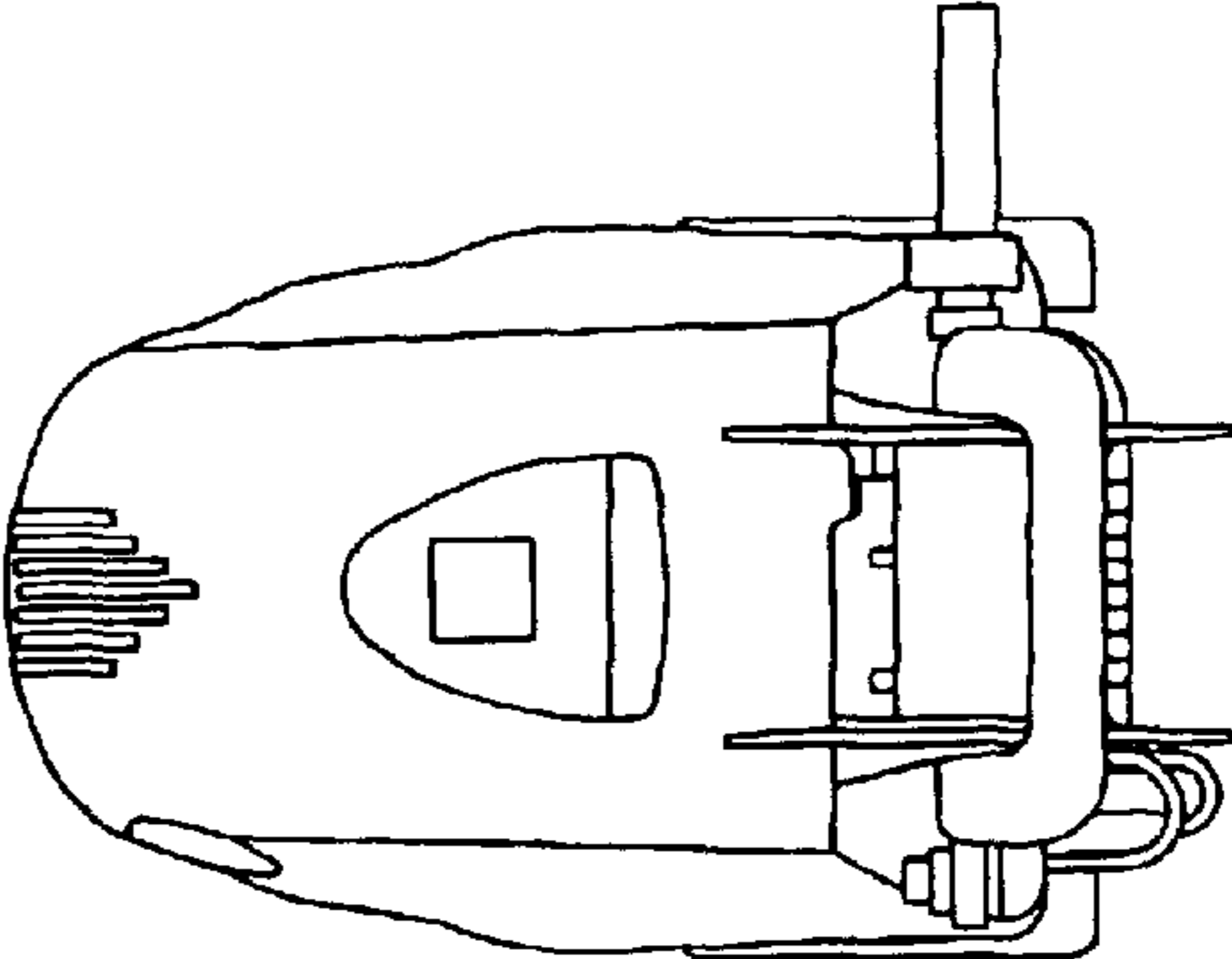

FIG.5

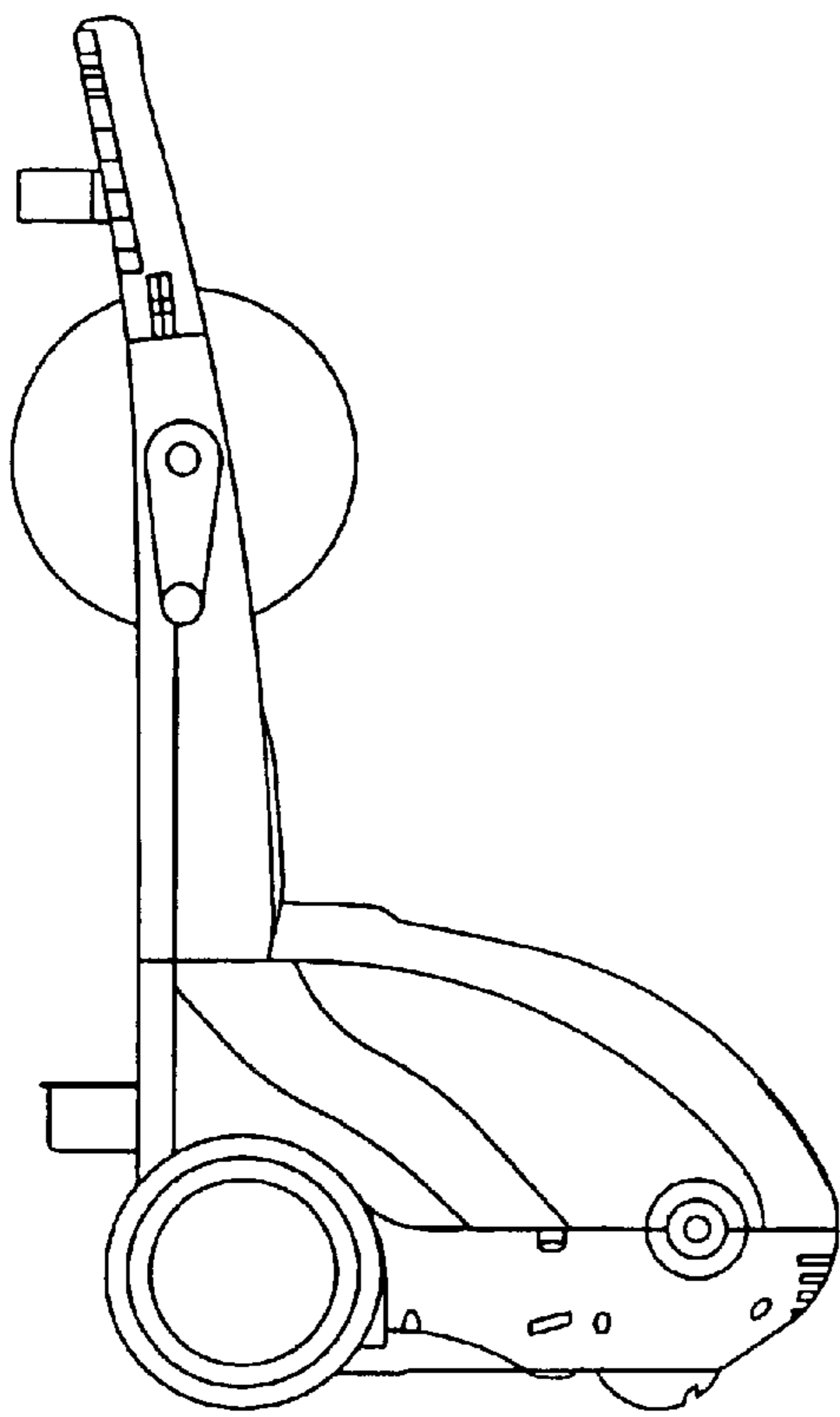

FIG. 6

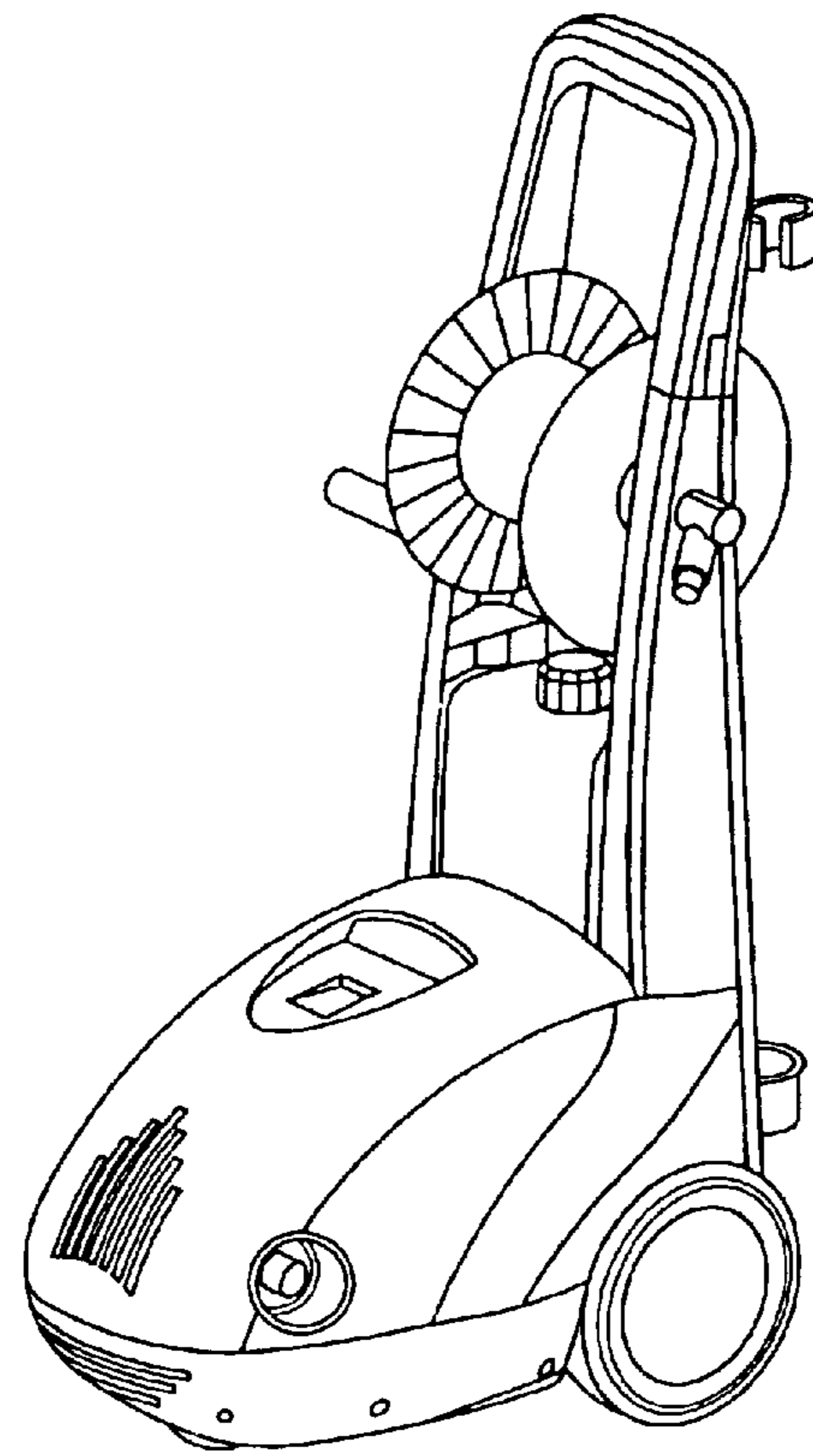

FIG. 7