

US00D496574S1

(12) **United States Design Patent**
Sakai et al.

(10) **Patent No.: US D496,574 S**
(45) **Date of Patent: ** Sep. 28, 2004**

(54) **PORTABLE ELECTRIC DRILL**
(75) Inventors: **Masato Sakai**, Hitachinaka (JP);
Kimitaka Abo, Hitachinaka (JP)
(73) Assignee: **Hitachi, Koki Co., Ltd.**, Tokyo (JP)
(**) Term: **14 Years**
(21) Appl. No.: **29/199,030**
(22) Filed: **Feb. 10, 2004**

D326,400 S * 5/1992 Fushiya et al. D8/68
D339,727 S * 9/1993 Kikuchi D8/68
D396,395 S * 7/1998 Zurwelle D8/68
D403,565 S * 1/1999 Chung D8/68
D406,742 S * 3/1999 Schoen et al. D8/68
D439,123 S * 3/2001 Sakai et al. D8/68
D441,268 S * 5/2001 Heun D8/68
6,240,816 B1 * 6/2001 Riedl et al. 81/429
D470,379 S * 2/2003 Andriolo D8/68
D470,737 S * 2/2003 Chunn et al. D8/68
6,536,537 B1 * 3/2003 Sasaki et al. 173/178
D482,254 S * 11/2003 Tsuzuki et al. D8/68
D486,049 S * 2/2004 Sugiura et al. D8/68

(30) **Foreign Application Priority Data**

Aug. 11, 2003 (JP) 2003-023377

(51) **LOC (7) Cl.** **08-01**
(52) **U.S. Cl.** **D8/68**
(58) **Field of Search** D8/14.1, 61, 62,
D8/63, 64, 65, 66, 67, 68, 69, 70; 81/57.11,
429, 464, 465, 466, 469, 489; 173/13, 169,
178, 213, 217; 227/8, 114, 120, 130, 136,
142; 310/50; 408/20, 124, 125, 234, 241 R;
451/358

FOREIGN PATENT DOCUMENTS

JP 1090000 11/2000

* cited by examiner

Primary Examiner—James Gandy
Assistant Examiner—T. Chase Nelson
(74) *Attorney, Agent, or Firm*—Sughrue Mion, PLLC

(57) **CLAIM**

The ornamental design for a portable electric drill, as shown.

(56) **References Cited**

U.S. PATENT DOCUMENTS

2,383,379 A * 8/1945 Forss 310/50
4,098,351 A * 7/1978 Alessio 173/13
D279,862 S * 7/1985 Sato et al. D8/68
D280,797 S * 10/1985 Sakamoto et al. D8/68
D280,883 S * 10/1985 Sakamoto et al. D8/68
D304,287 S * 10/1989 Zurwelle D8/68
4,968,191 A * 11/1990 Palm 408/124
D314,498 S * 2/1991 Hoshino et al. D8/68
5,056,607 A * 10/1991 Sanders 173/48
D325,860 S * 5/1992 Fushiya et al. D8/68

DESCRIPTION

FIG. 1 is a perspective view of the top, front and left side elevational view thereof;
FIG. 2 is a front elevational view thereof;
FIG. 3 is a rear elevational view thereof;
FIG. 4 is a left side elevational view thereof;
FIG. 5 is a right side elevational view thereof;
FIG. 6 is a top plan view thereof; and,
FIG. 7 is a bottom plan view thereof.

1 Claim, 5 Drawing Sheets

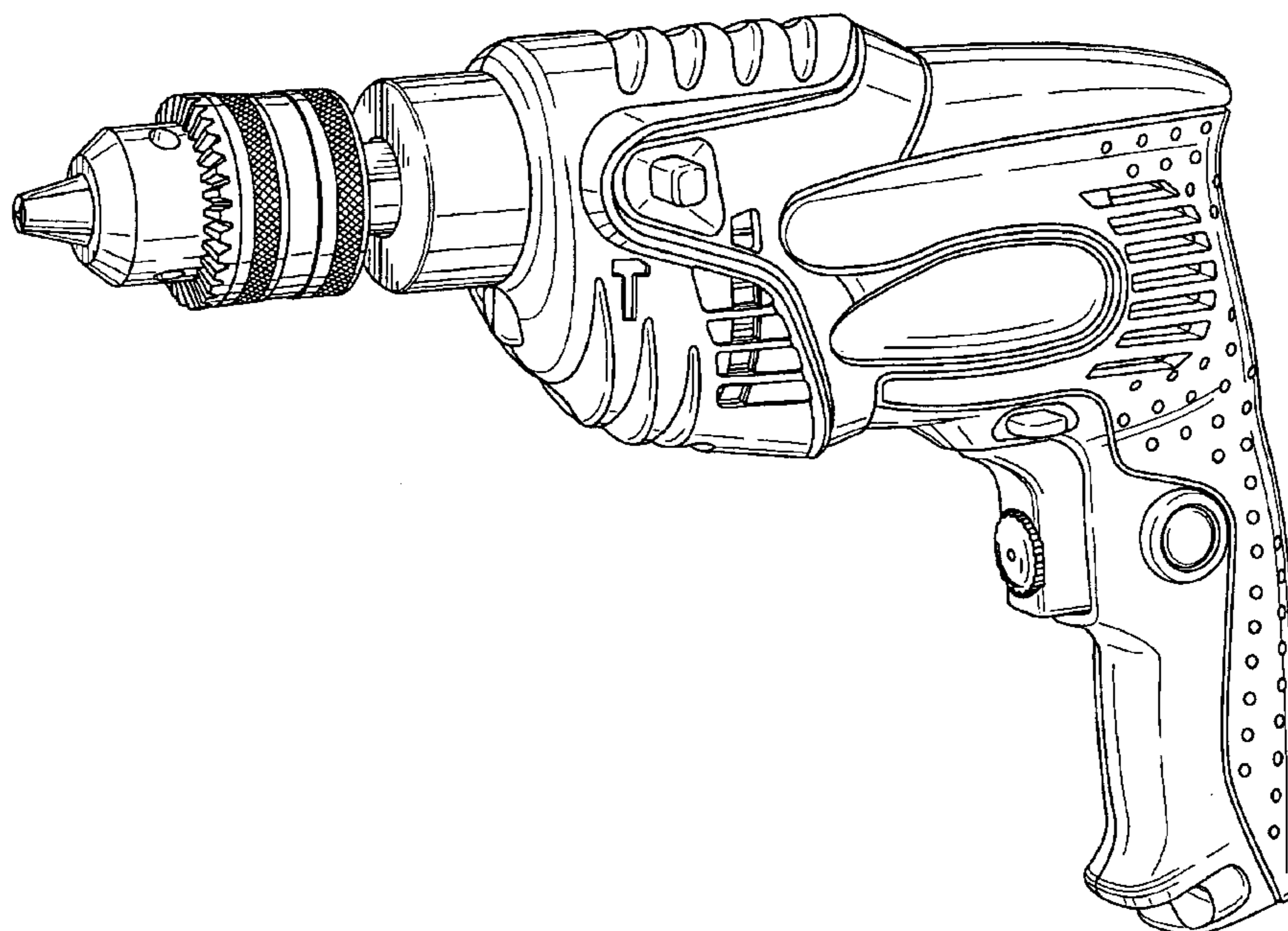

FIG. 1

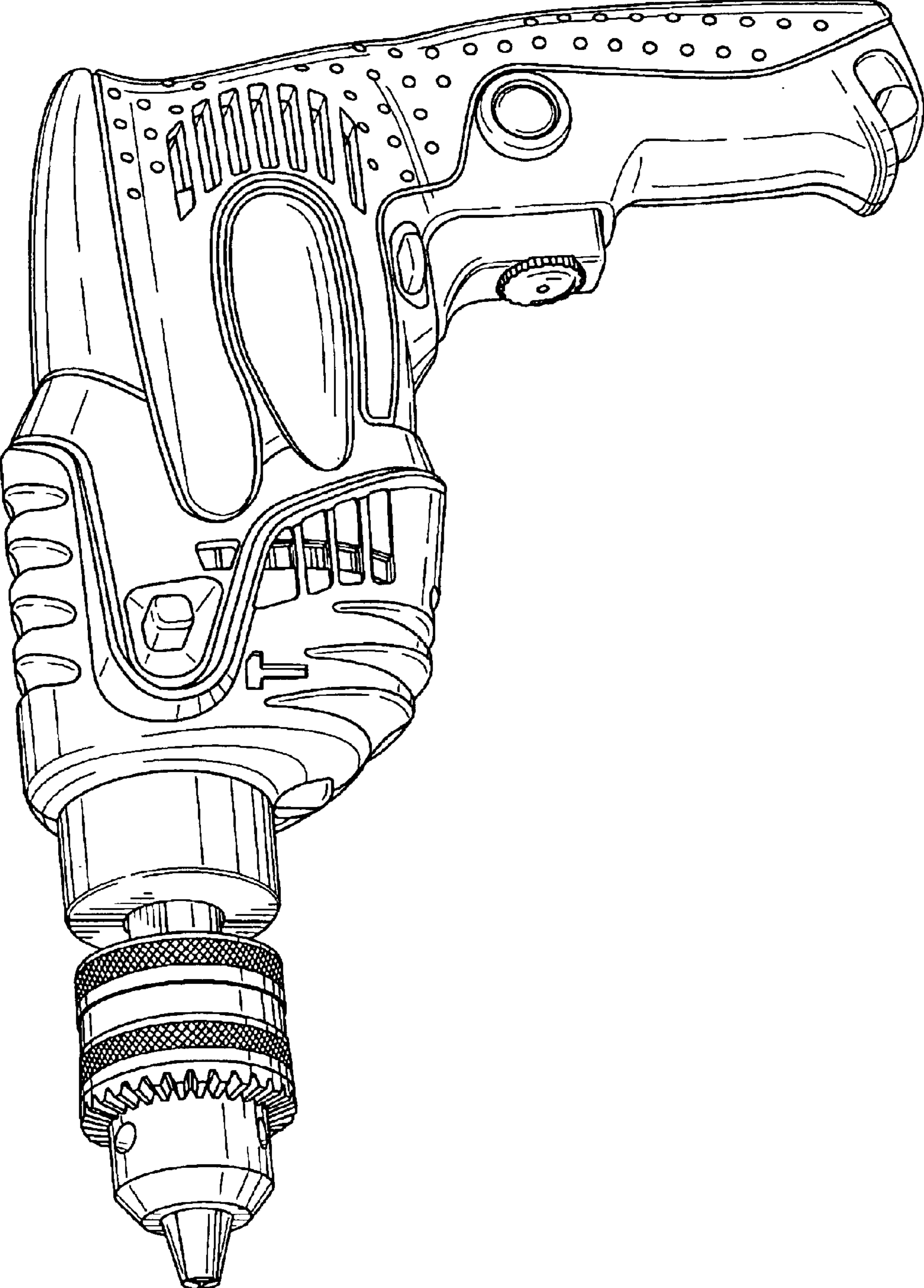

FIG. 2

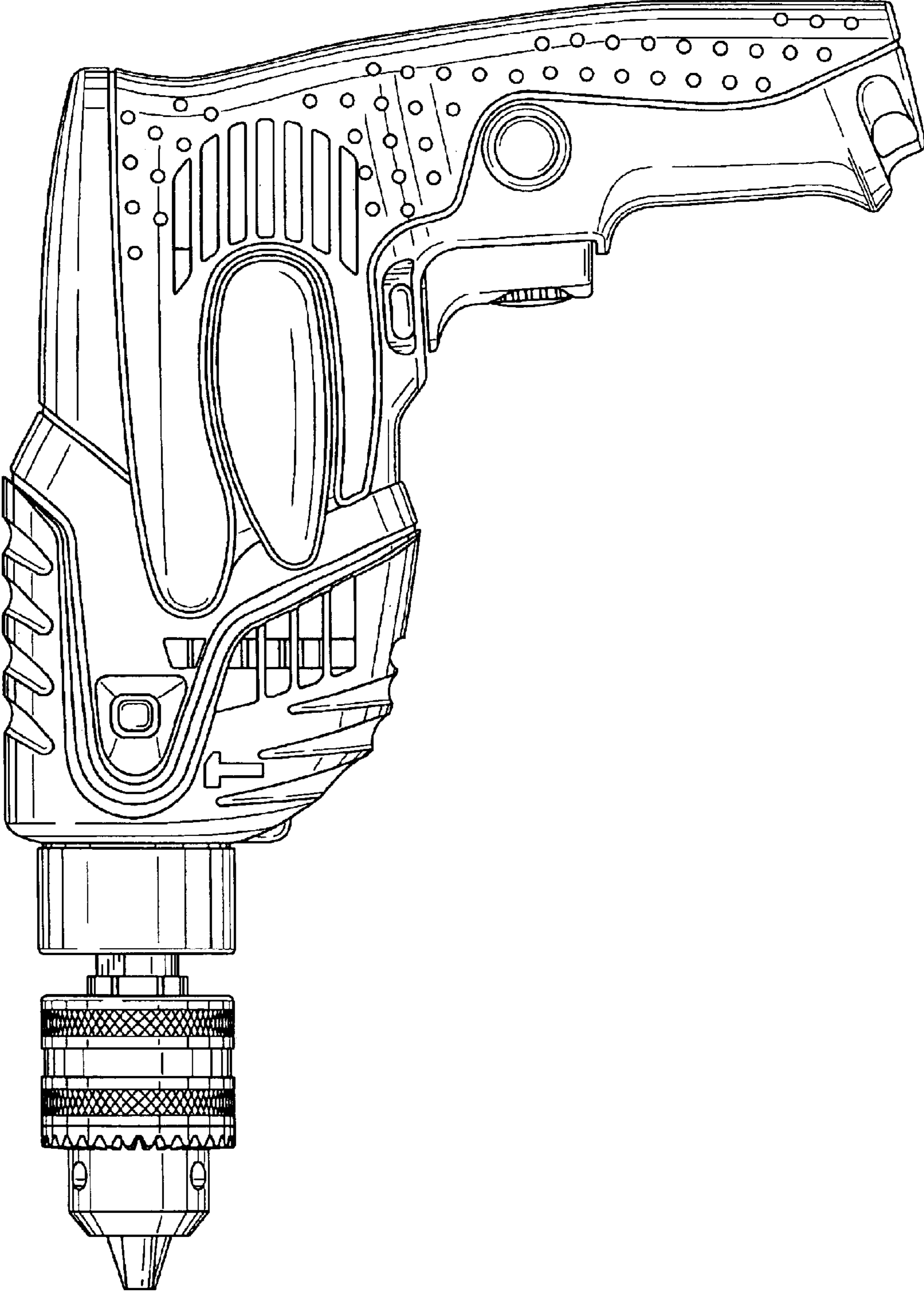

FIG. 3

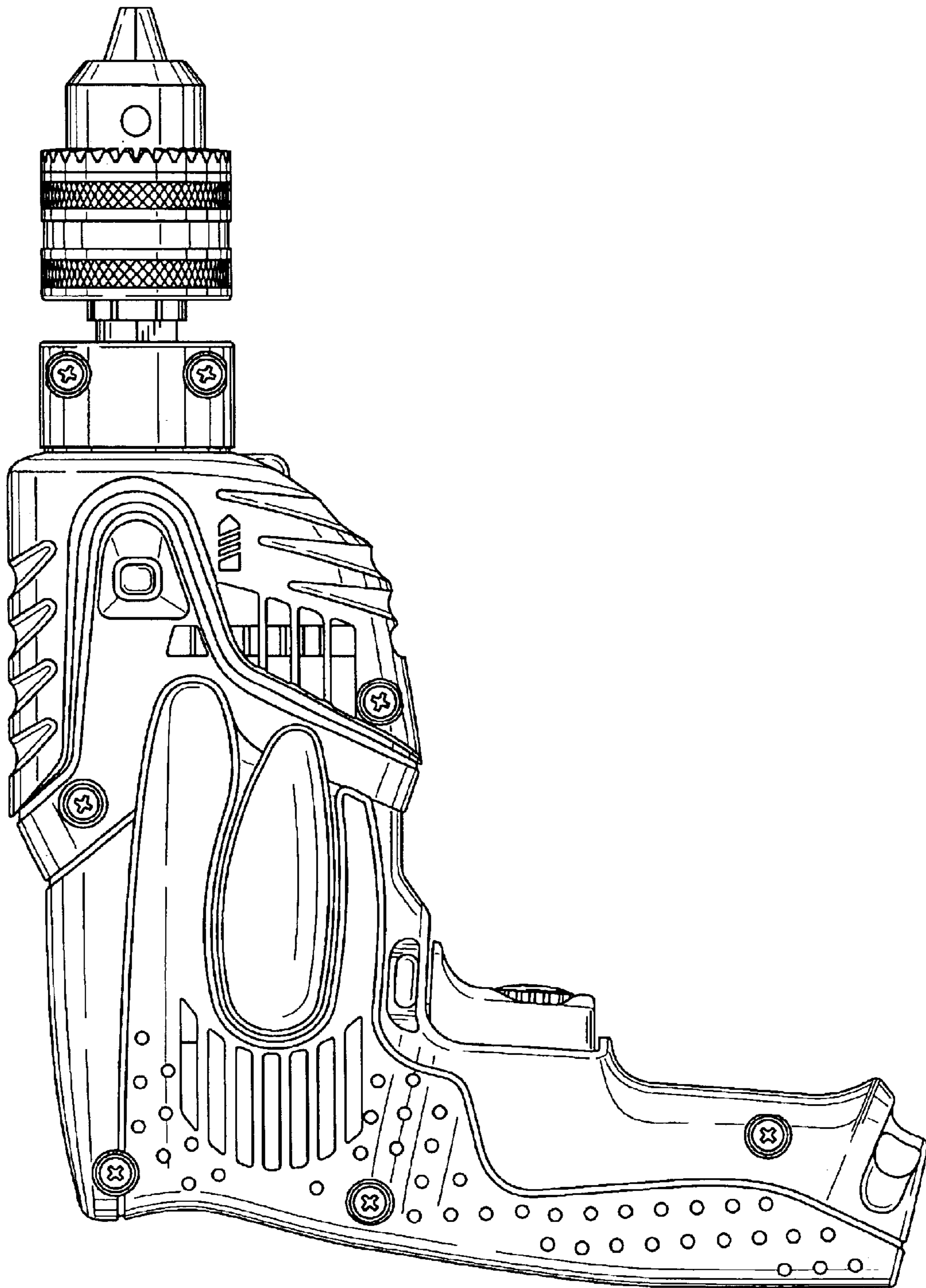

FIG. 4

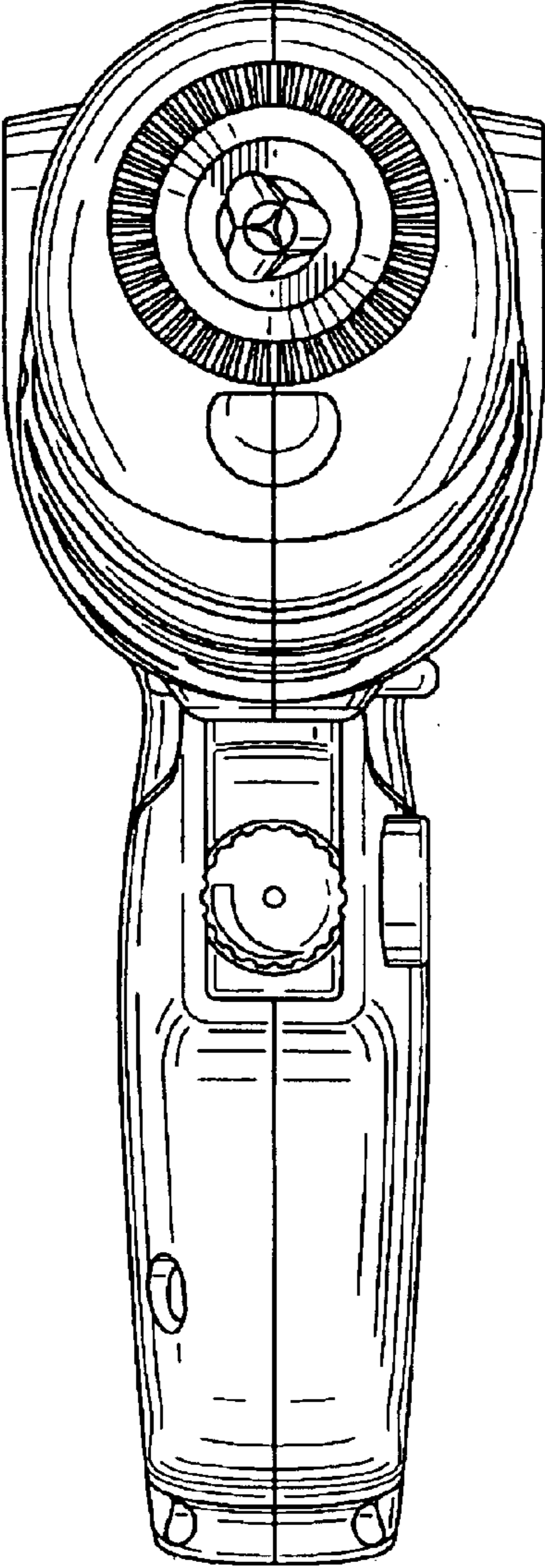

FIG. 5

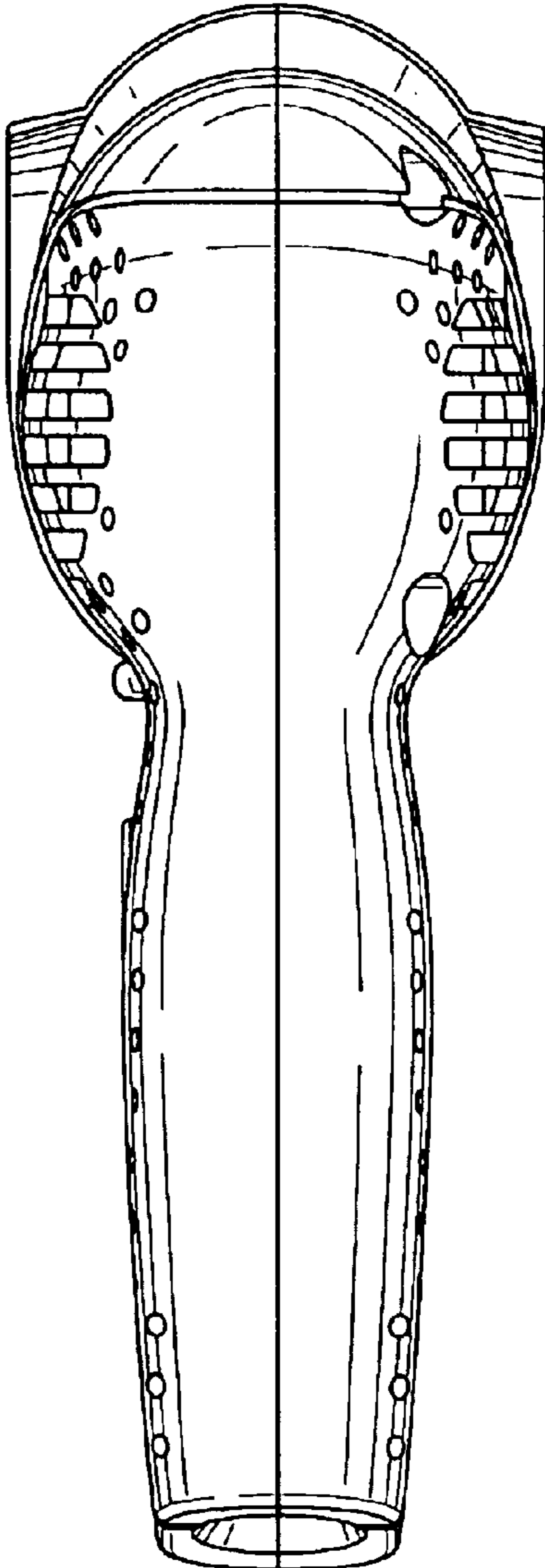

FIG. 6

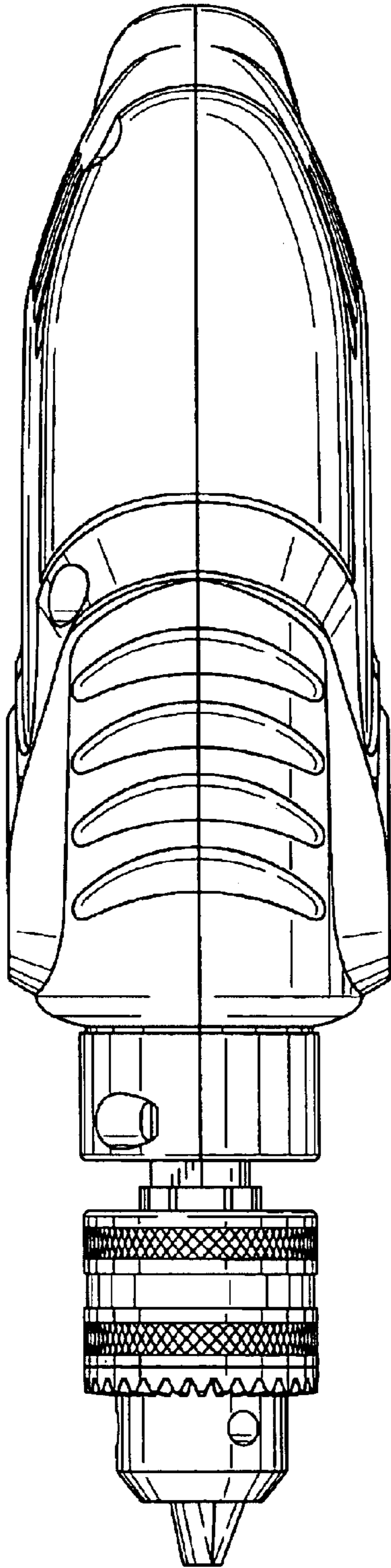

FIG. 7

