

US00D496309S1

(12) **United States Design Patent**  
**Fukumoto et al.**

(10) **Patent No.:** **US D496,309 S**

(45) **Date of Patent:** **\*\* Sep. 21, 2004**

(54) **MOTORCYCLE**

(75) Inventors: **Keishi Fukumoto**, Akashi (JP); **Shoji Idei**, Kakogawa (JP)

(73) Assignee: **Kawasaki Jukogyo Kabushiki Kaisha**, Hyogo (JP)

(\*\*) Term: **14 Years**

(21) Appl. No.: **29/177,249**

(22) Filed: **Mar. 6, 2003**

(30) **Foreign Application Priority Data**

Sep. 13, 2002 (JP) ..... 2002-024982

(51) **LOC (7) Cl.** ..... **12-11**

(52) **U.S. Cl.** ..... **D12/110**

(58) **Field of Search** ..... D12/110; 180/219

(56) **References Cited**

**PUBLICATIONS**

Cycle World Feb. 2000, Kawasaki Ninja ® ZX-12R 2000, unnumbered inset.\*

Cycle World Jun. 1999, Kawasaki Ninja ® ZX-12 on pp. 28 and 29.\*

Henshaw, Peter. The Encyclodedia of the Motorcycle. N.J., Chartwell Books, Inc. 1999. Kawasaki Ninja ® 1998 ZX9-R.\*

\* cited by examiner

*Primary Examiner*—Alan P. Douglas

*Assistant Examiner*—Linda Brooks

(57) **CLAIM**

The ornamental design for a motorcycle, as shown and described.

**DESCRIPTION**

FIG. 1 is a front elevational view of the motorcycle showing our new design;

FIG. 2 is a rear elevational view thereof;

FIG. 3 is a right side elevational view thereof;

FIG. 4 is a left side elevational view thereof;

FIG. 5 is a top plan view thereof;

FIG. 6 is a bottom plan view thereof; and

FIG. 7 is a front right perspective view thereof; and,

FIG. 8 is a rear left perspective view thereof.

**1 Claim, 7 Drawing Sheets**

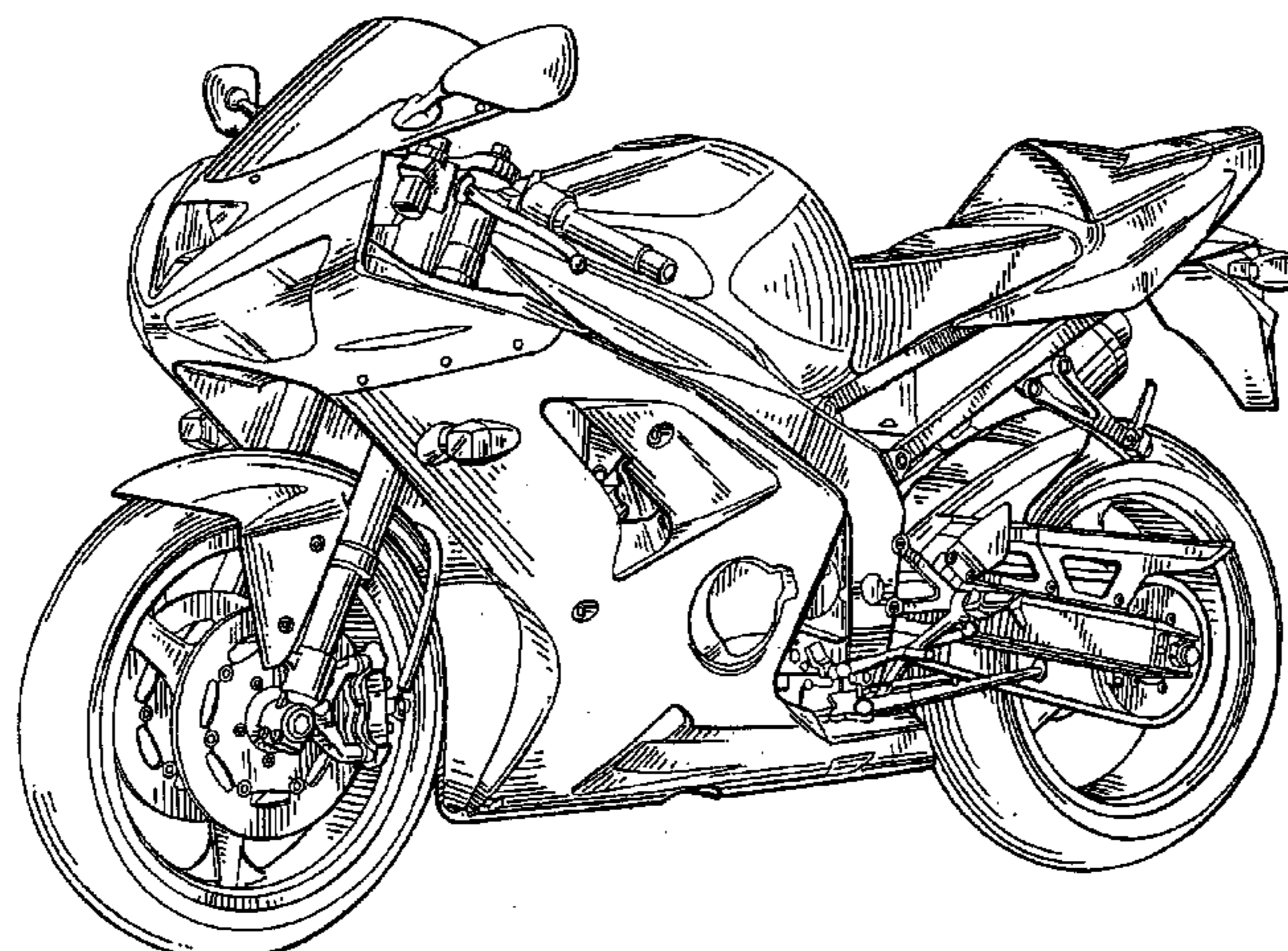
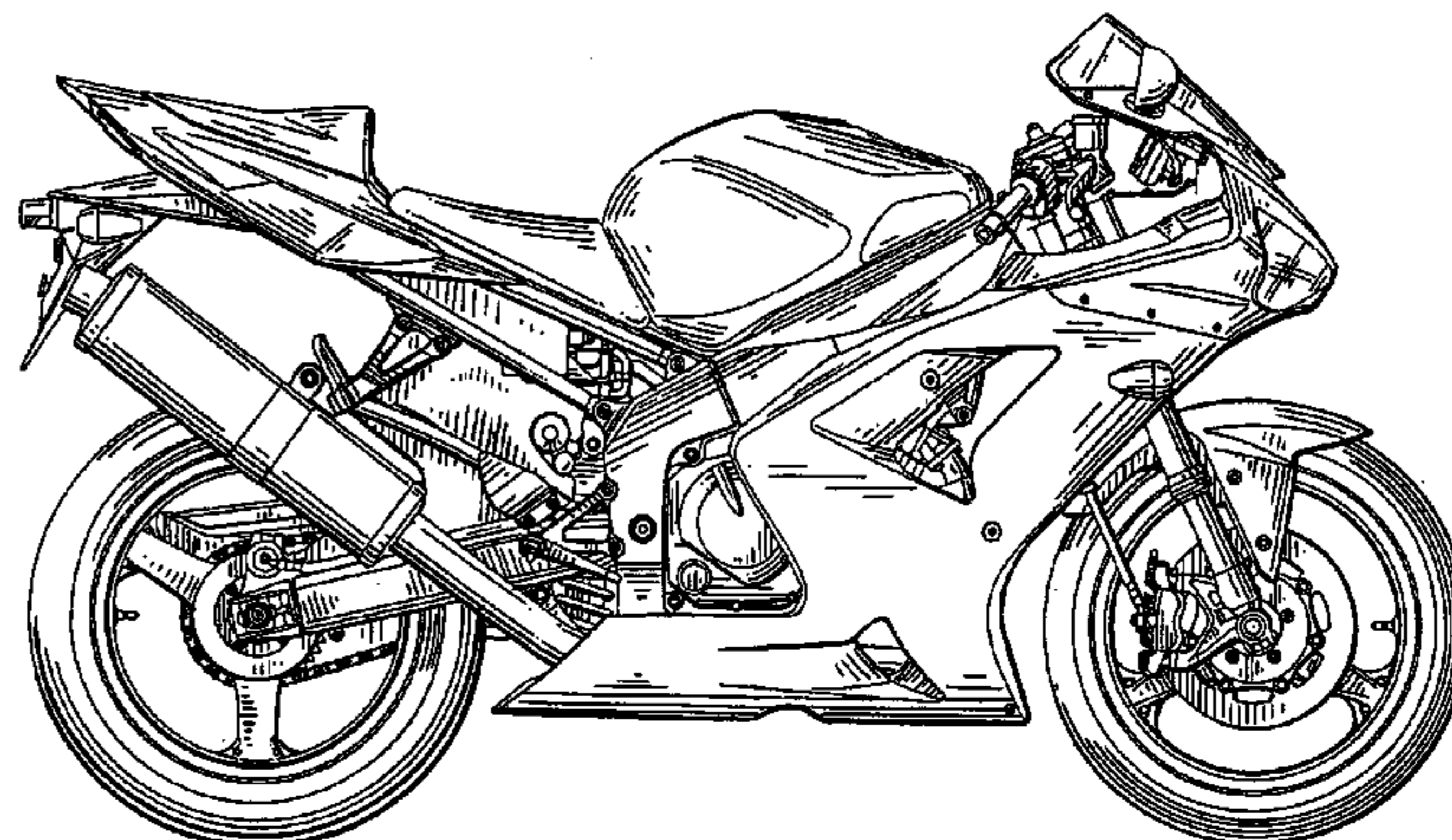

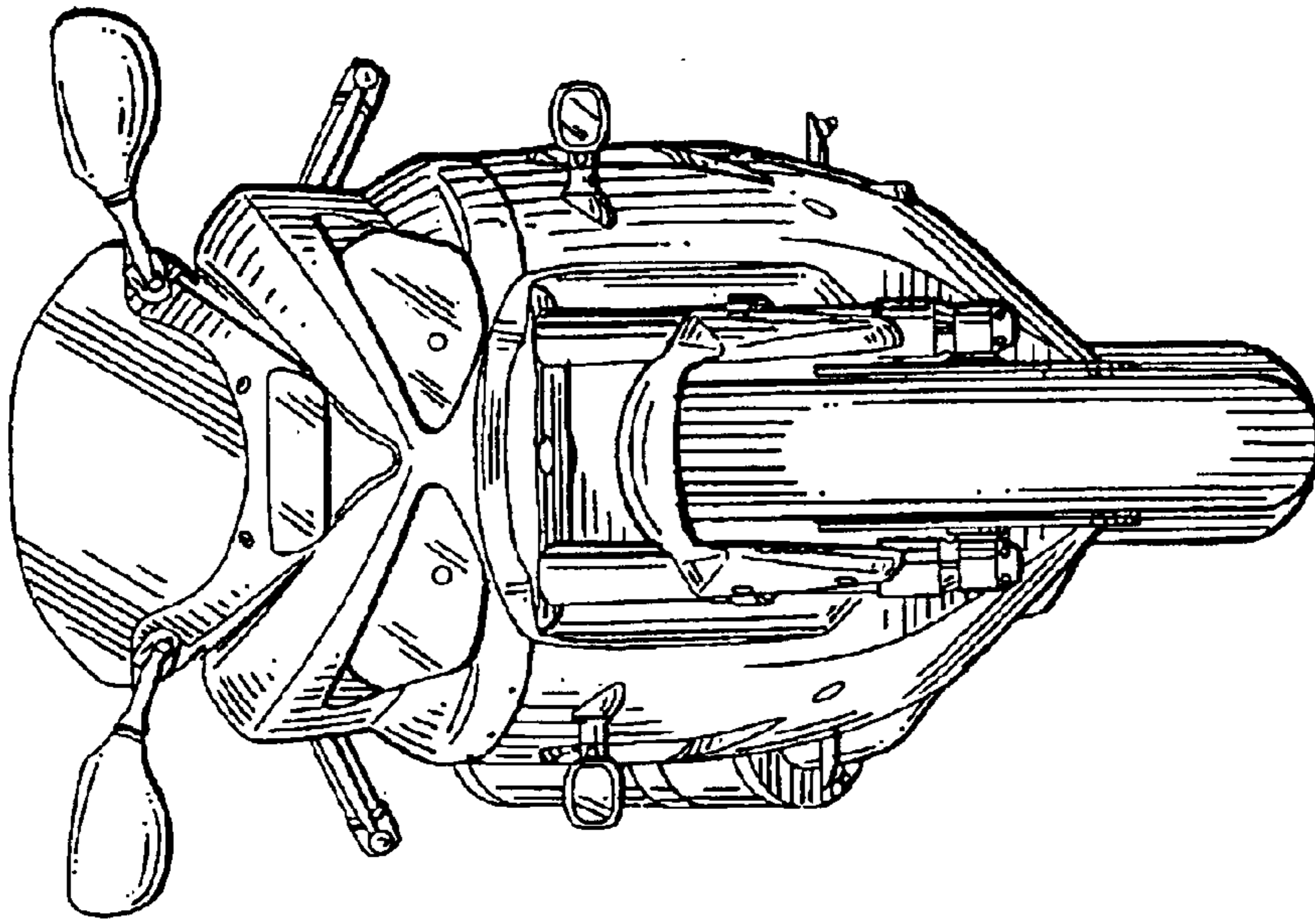

FIG. 1

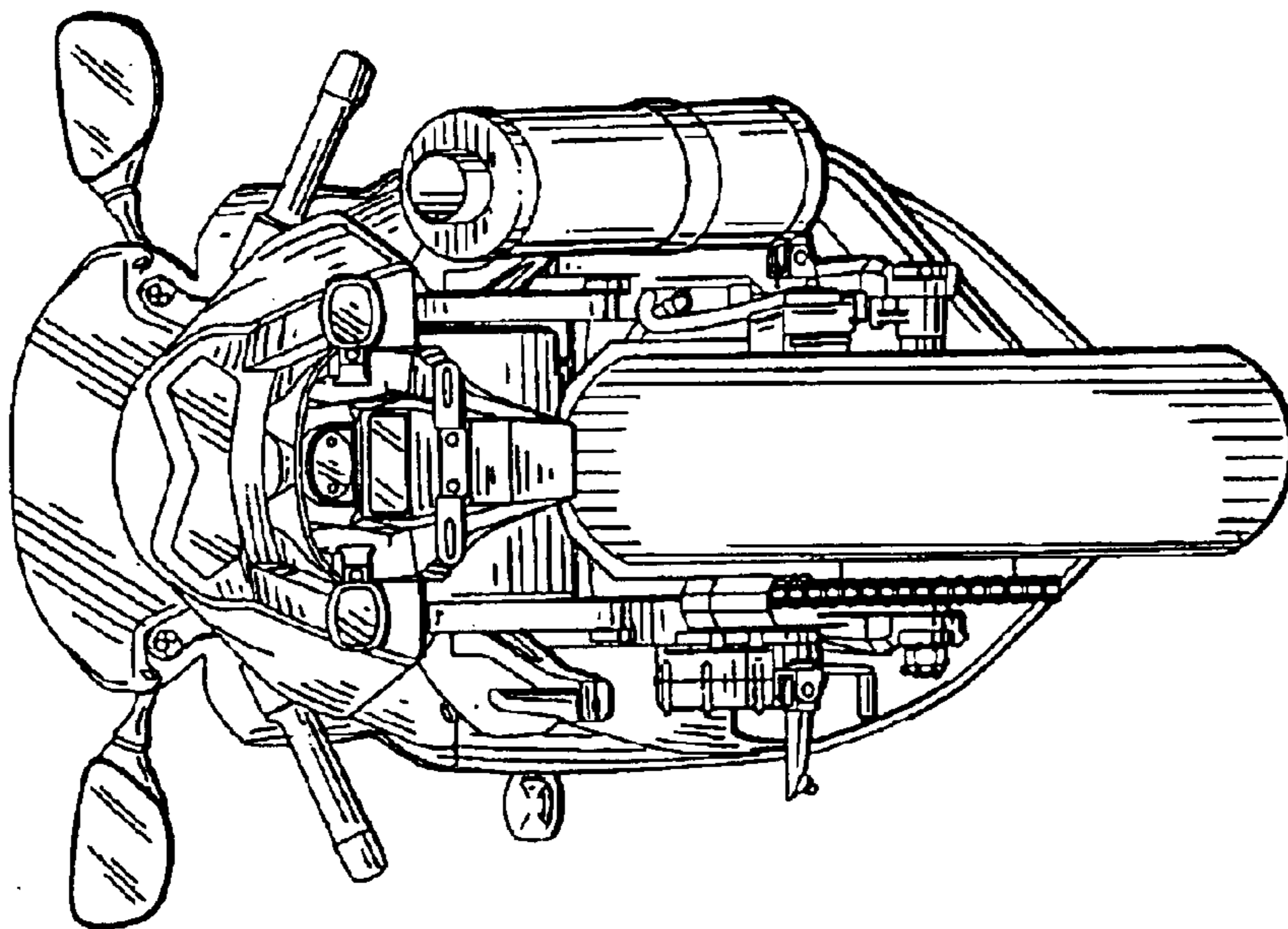

FIG. 2

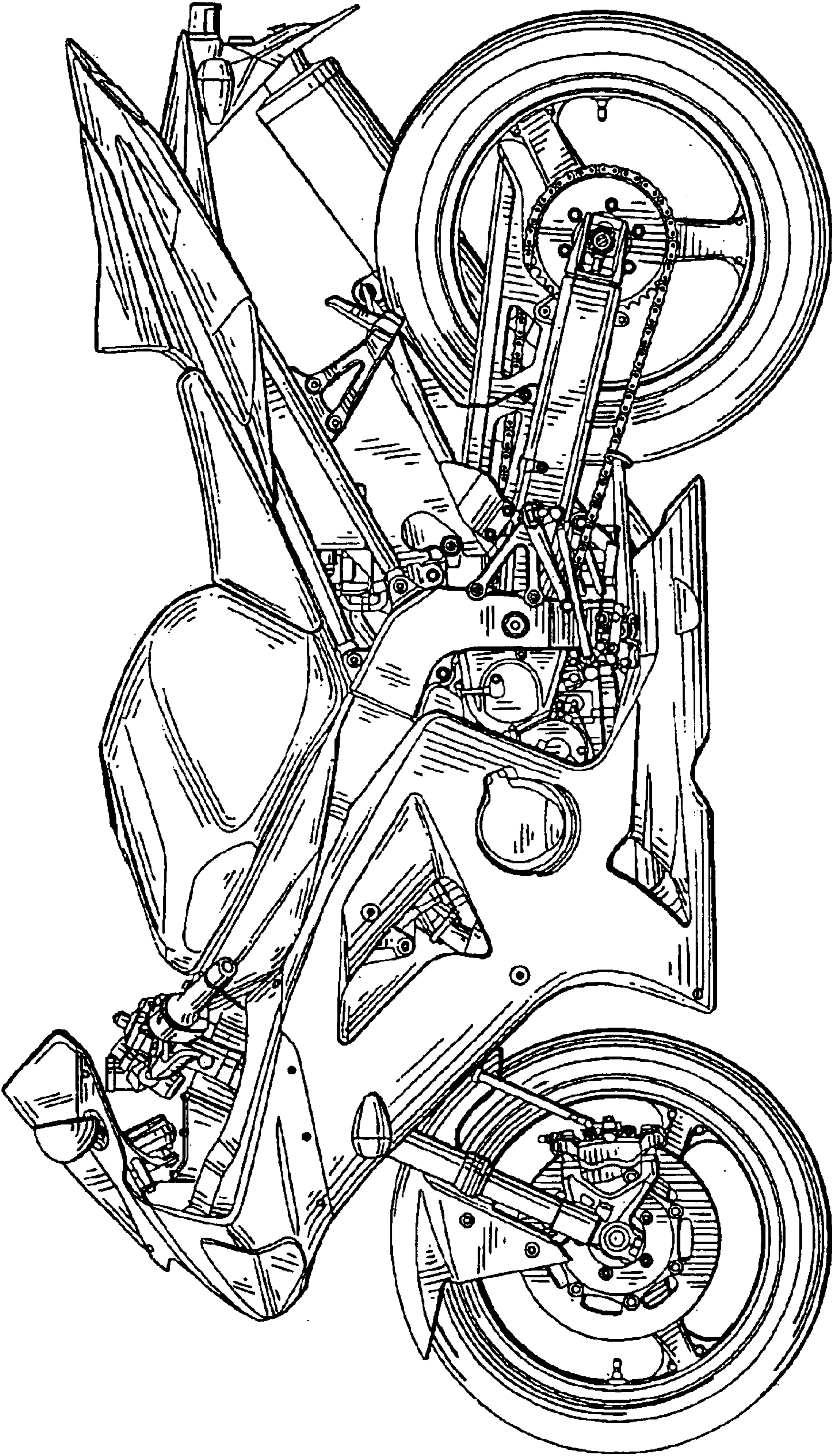

FIG. 3

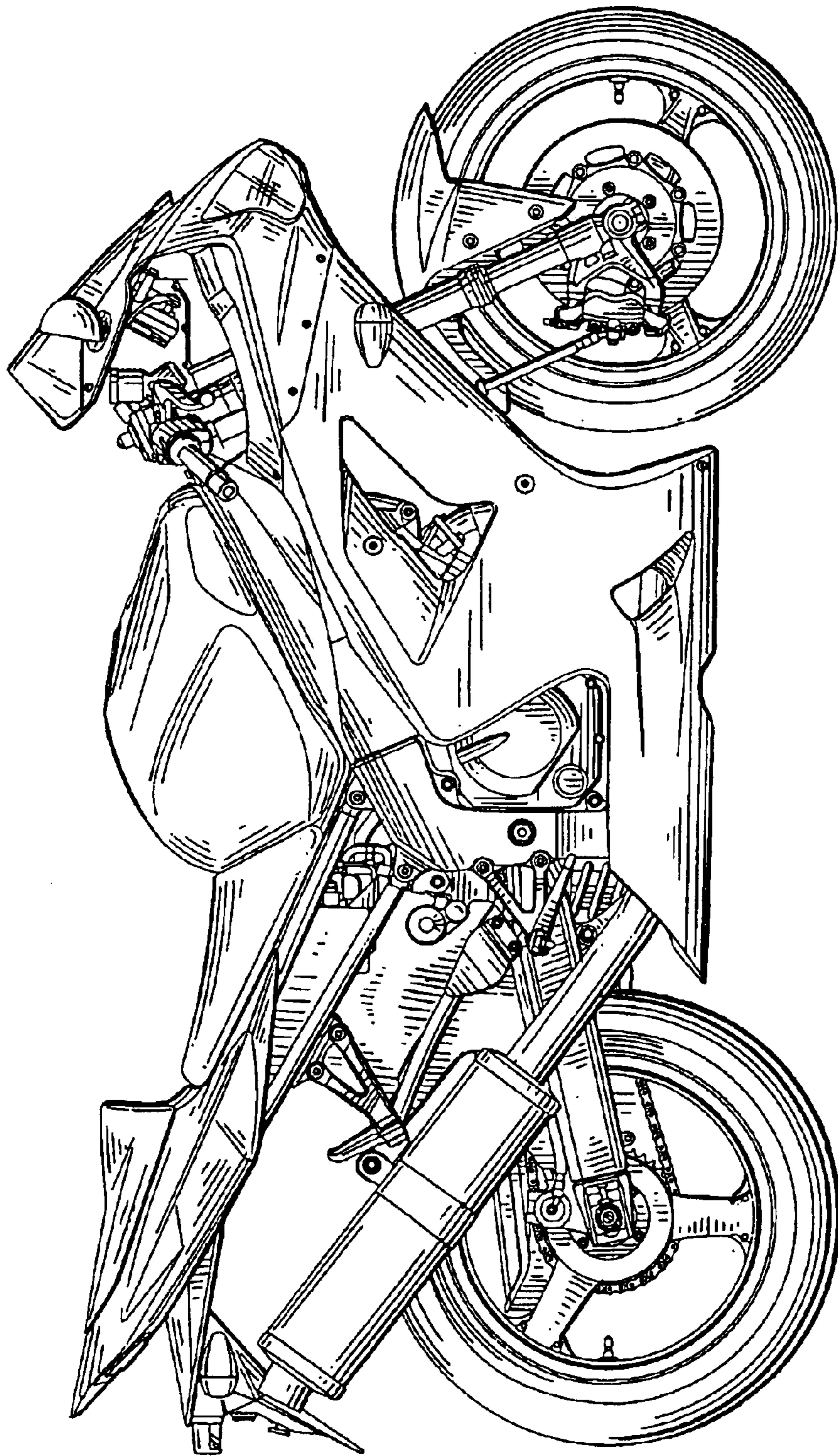

FIG. 4

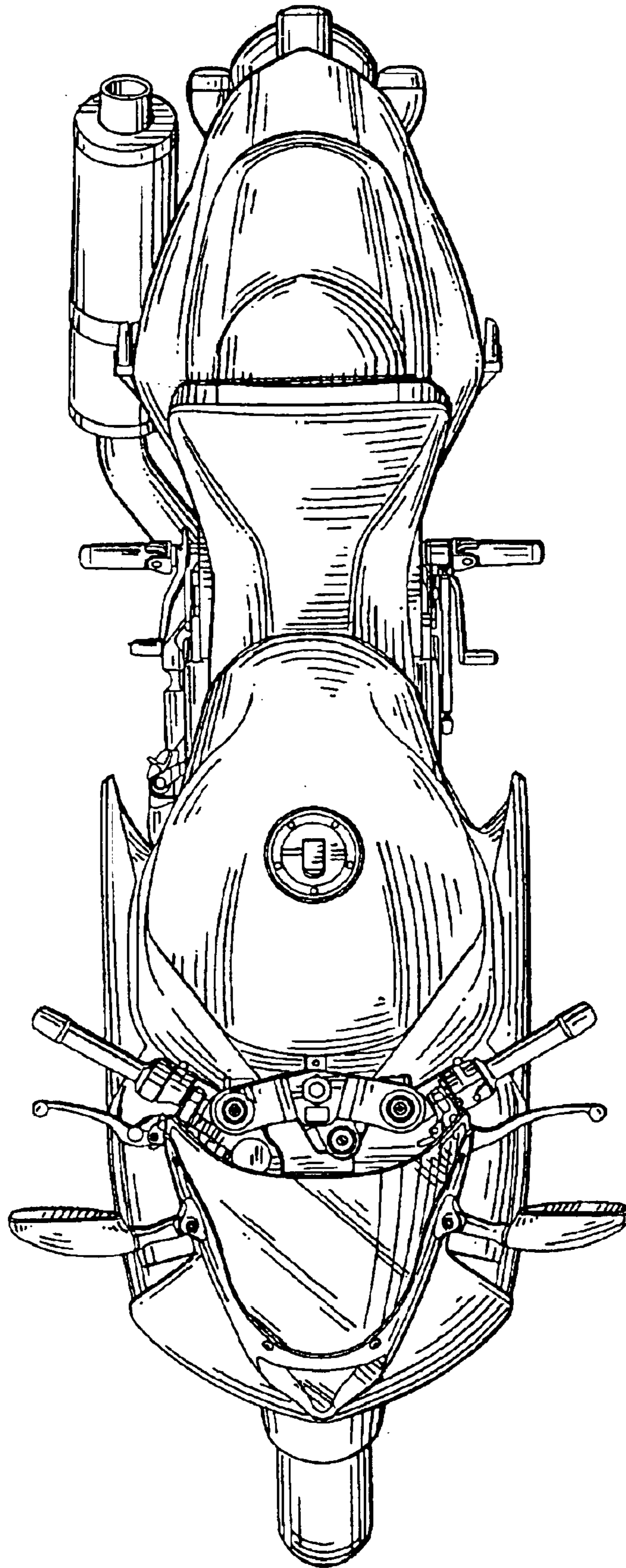

FIG. 5

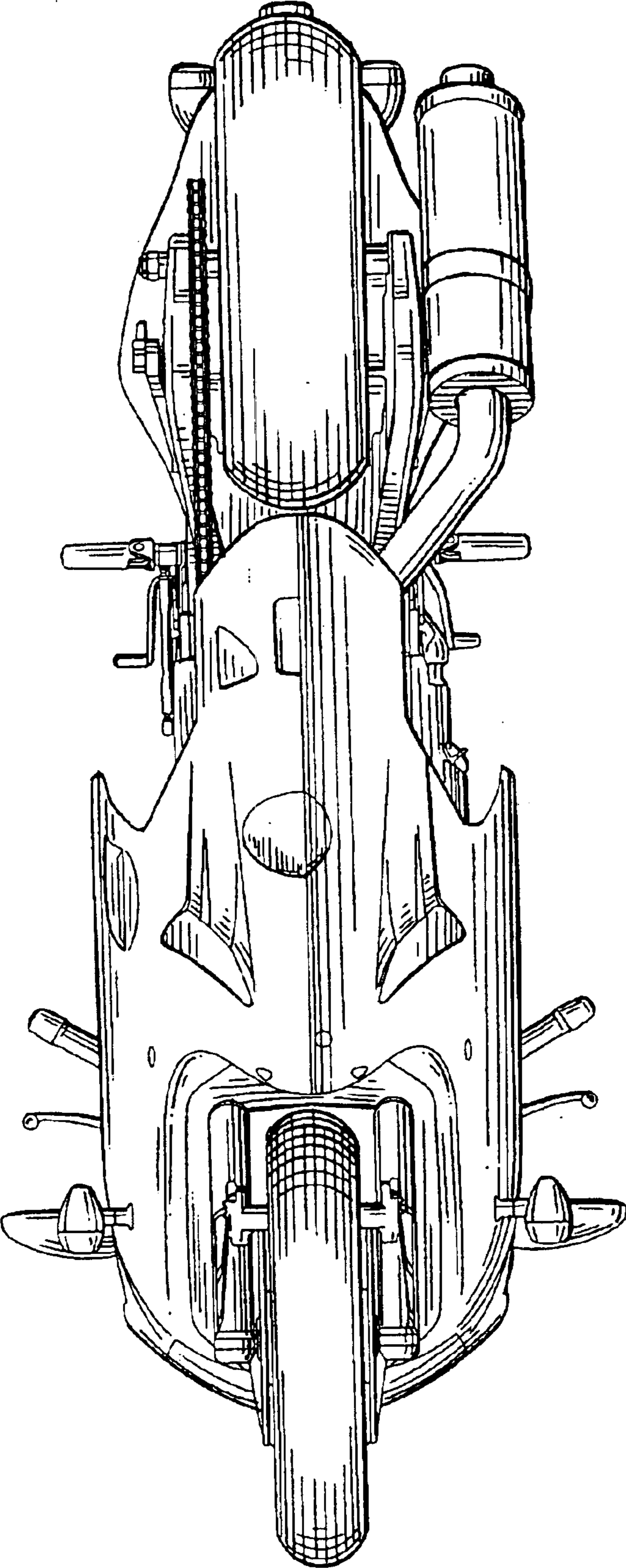

FIG. 6

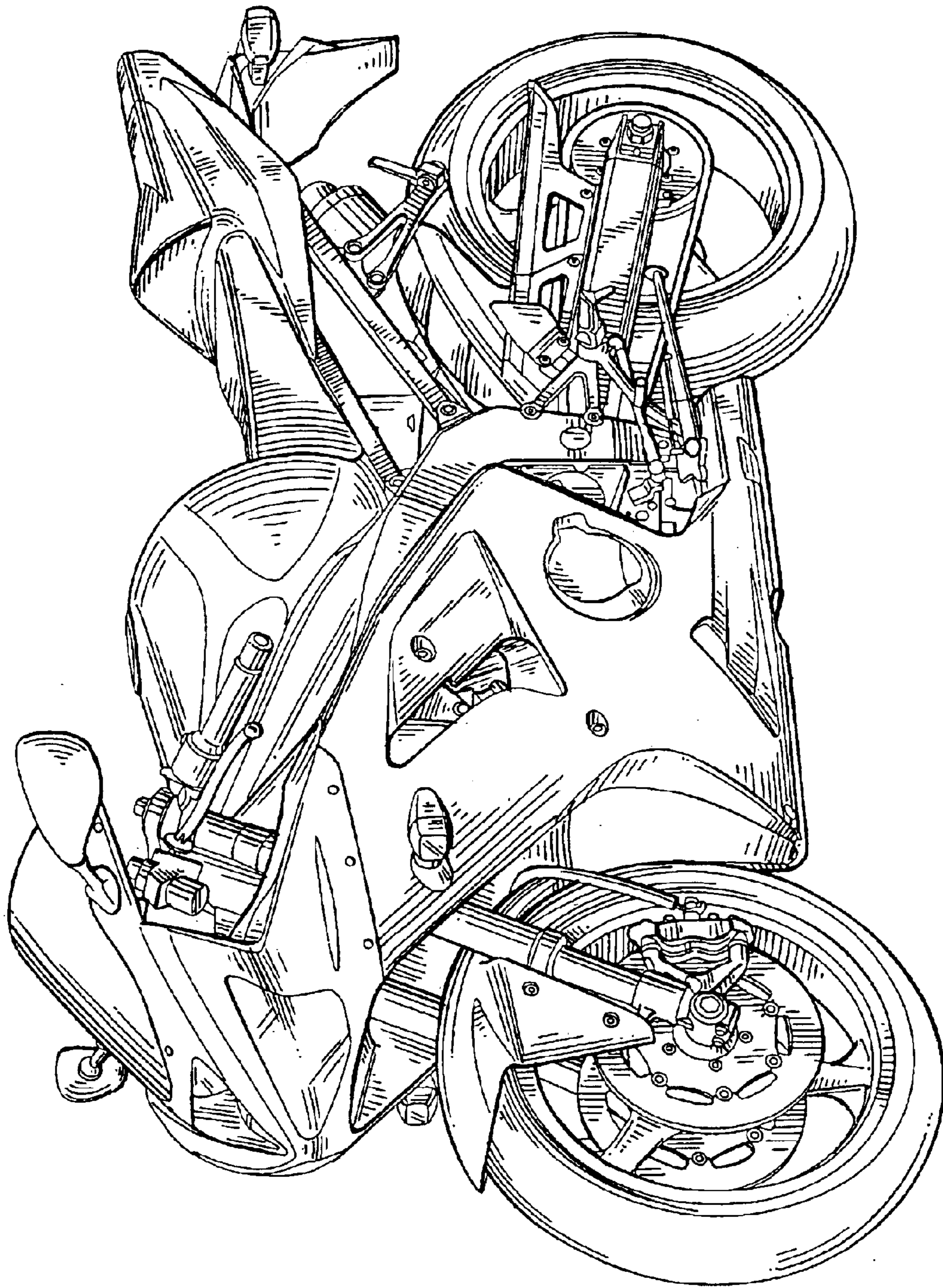

FIG. 7

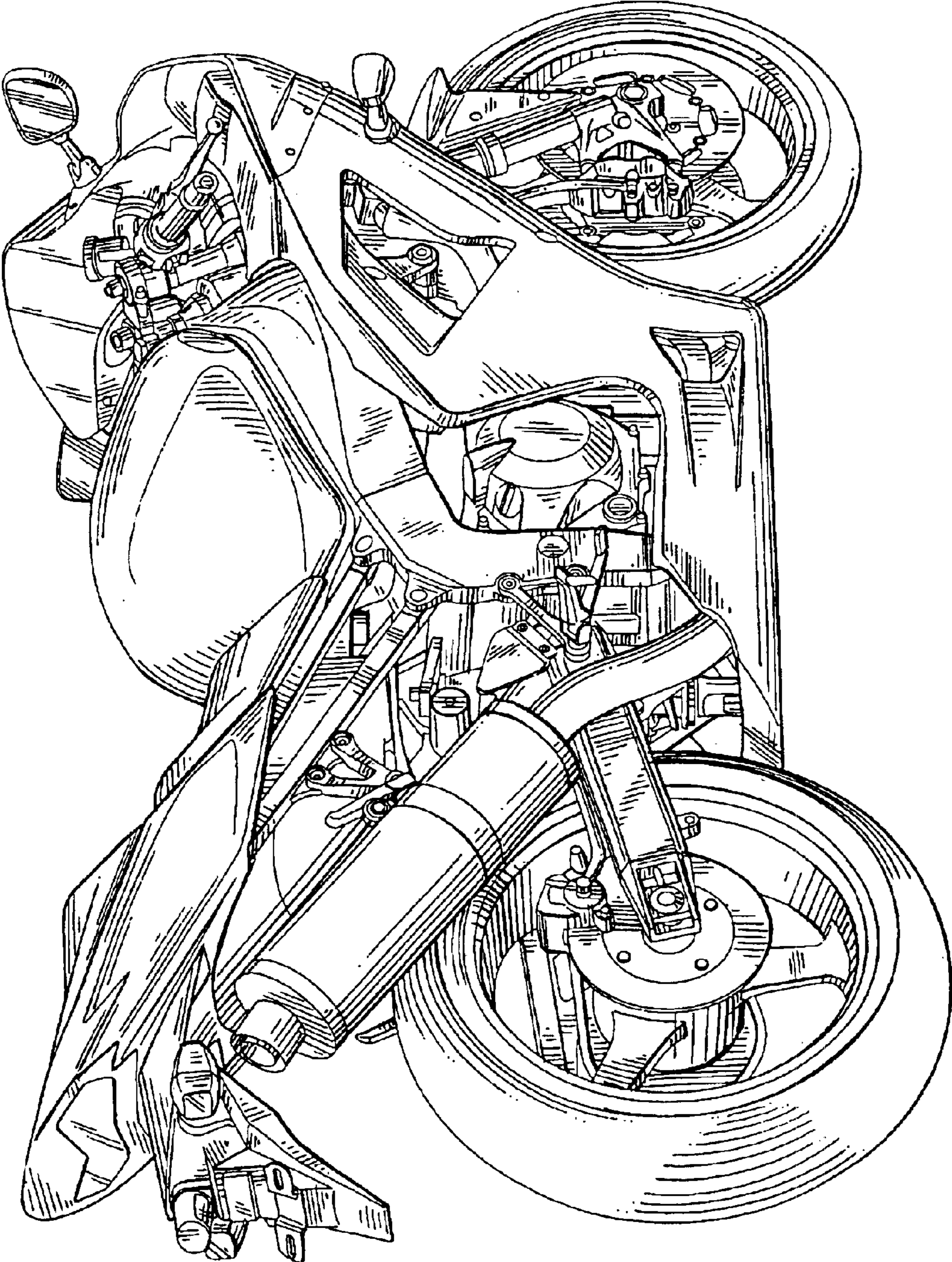

FIG. 8