

US00D496249S1

(12) **United States Design Patent** (10) **Patent No.:** **US D496,249 S**
Liebendorfer (45) **Date of Patent:** **** Sep. 21, 2004**

(54) **HEAVY-DUTY RAIL**

(75) Inventor: **John E. Liebendorfer**, Albuquerque, NM (US)

(73) Assignee: **Unirac, Inc.**, Albuquerque, NM (US)

(**) Term: **14 Years**

(21) Appl. No.: **29/177,275**

(22) Filed: **Jun. 9, 2003**

(51) **LOC (7) Cl.** **08-05**

(52) **U.S. Cl.** **D8/354**

(58) **Field of Search** D8/349, 354, 373, D8/376, 380; D25/119, 120, 121, 122, 123, 124, 125; 52/720.1, 724.1, 736.1, 730.1, 731.1, 737.1; 428/36.9, 122

(56) **References Cited**

U.S. PATENT DOCUMENTS

D261,311 S	*	10/1981	Schmidt	D25/124
D330,264 S	*	10/1992	Valentin	D25/124
D357,077 S	*	4/1995	Franson	D25/124
D431,658 S	*	10/2000	Gregori	D25/122
D469,886 S	*	2/2003	Barnett	D25/119
D471,286 S	*	3/2003	Roberts et al.	D25/60
6,668,500 B1	*	12/2003	Lamberts	52/204.72

* cited by examiner

Primary Examiner—Joel Sincavage
Assistant Examiner—Elizabeth Albert
(74) *Attorney, Agent, or Firm*—Ray R. Regan

(57) **CLAIM**

The ornamental design for the heavy-duty rail, as shown and described.

DESCRIPTION

FIG. 1 is a perspective view of the invention showing the new design;

FIG. 2 shows a right side elevational view of the invention shown in FIG. 1;

FIG. 3 shows a left side elevational view of the invention shown in FIG. 1;

FIG. 4 shows a front elevational view of the invention shown in FIG. 1;

FIG. 5 shows a rear elevational view of the Invention shown in FIG. 1;

FIG. 6 shows a top view of the Invention shown in FIG. 1; and,

FIG. 7 shows a bottom view of the Invention shown in FIG. 1.

The broken lines showing environment in the drawing are for illustrative purposes only, and form no part of the claimed design.

1 Claim, 4 Drawing Sheets

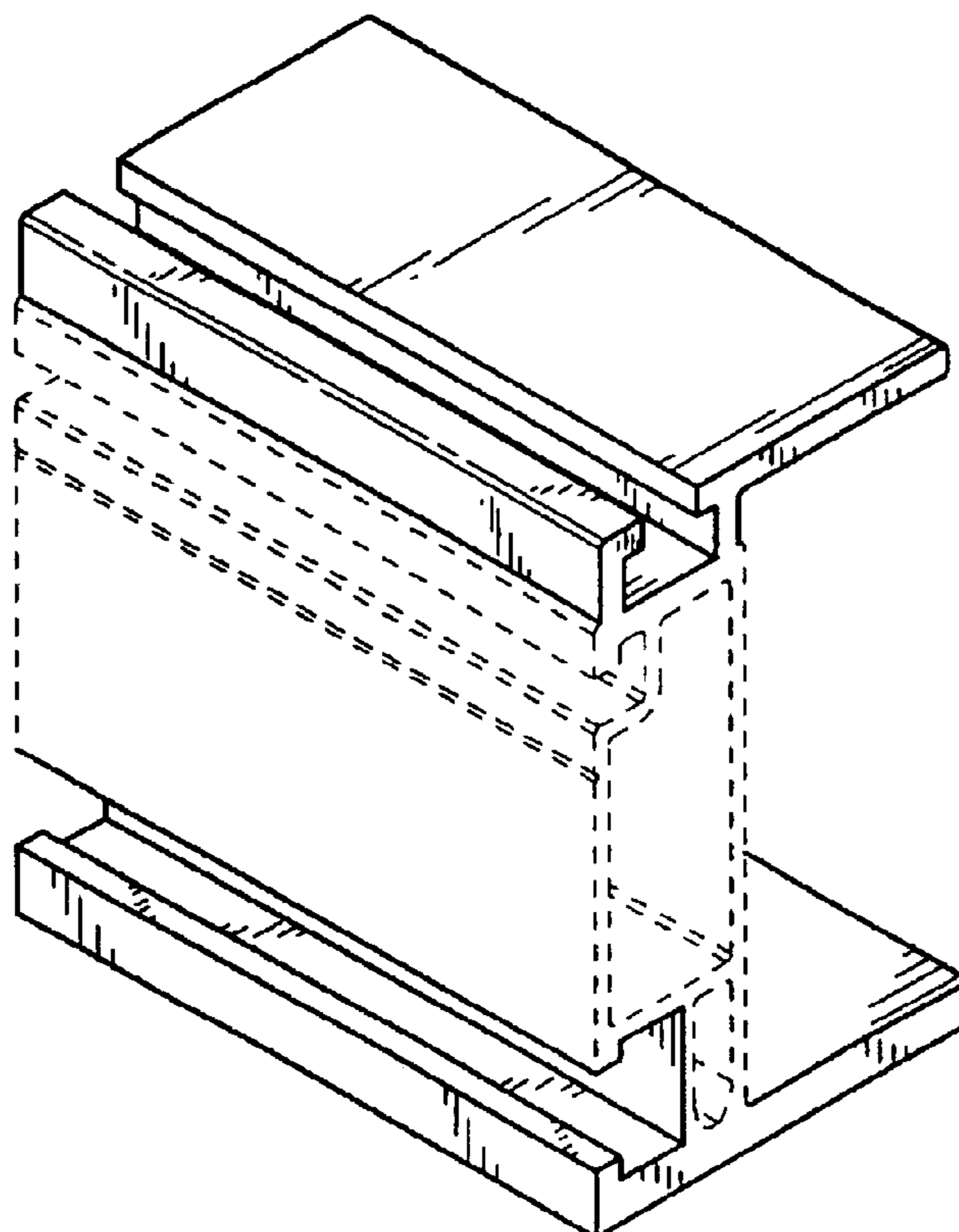

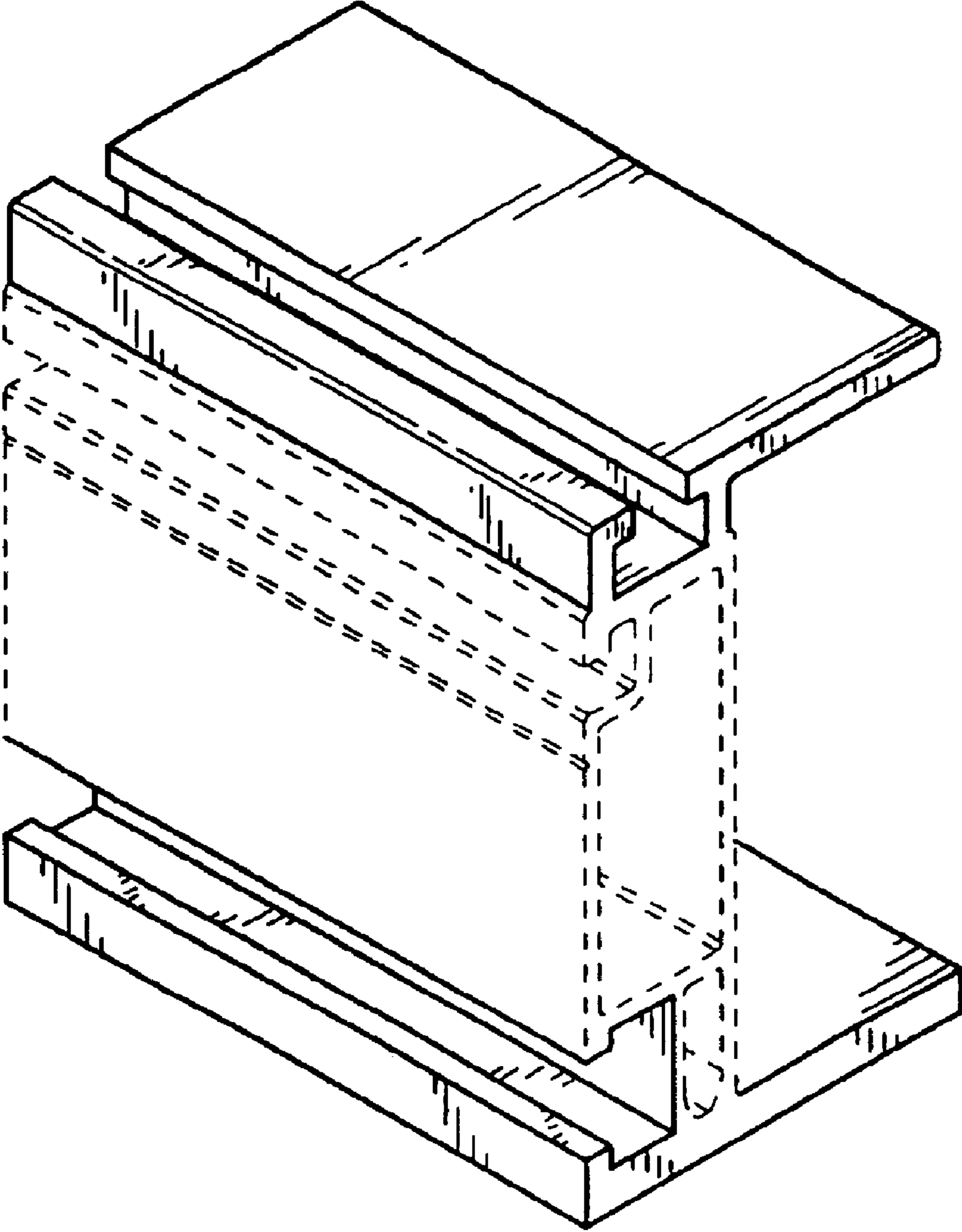

FIG.1

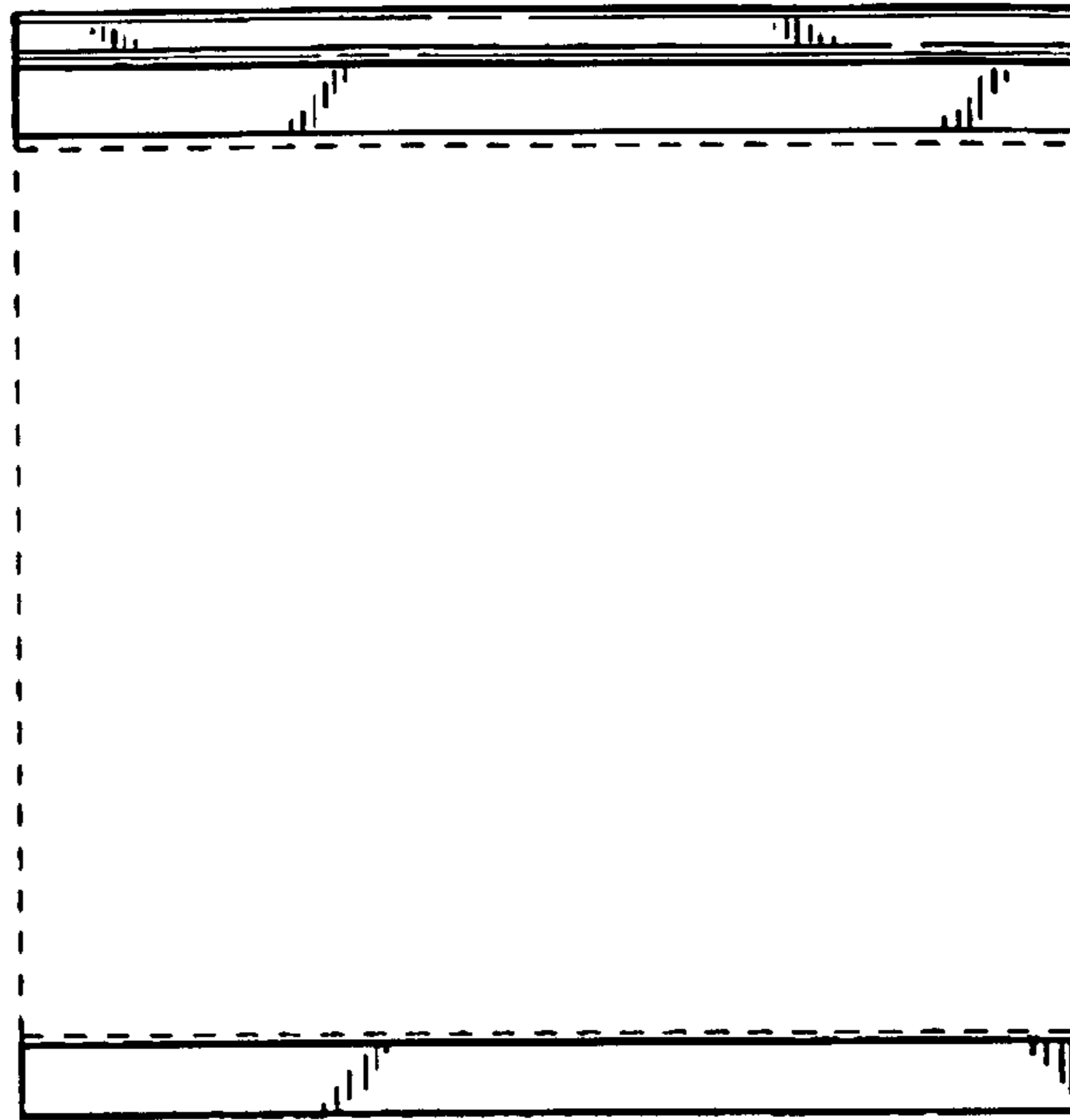

FIG. 2

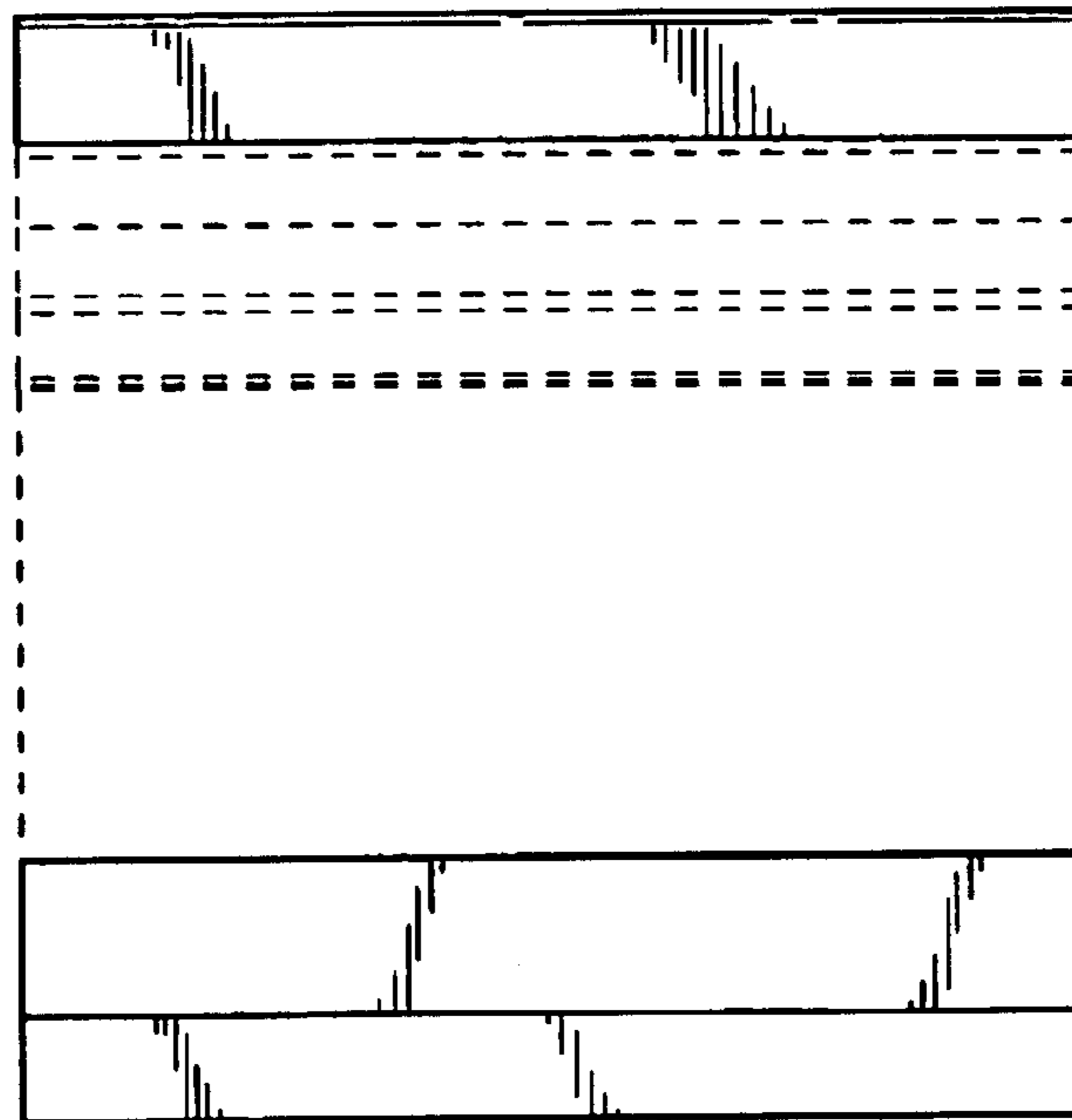

FIG. 3

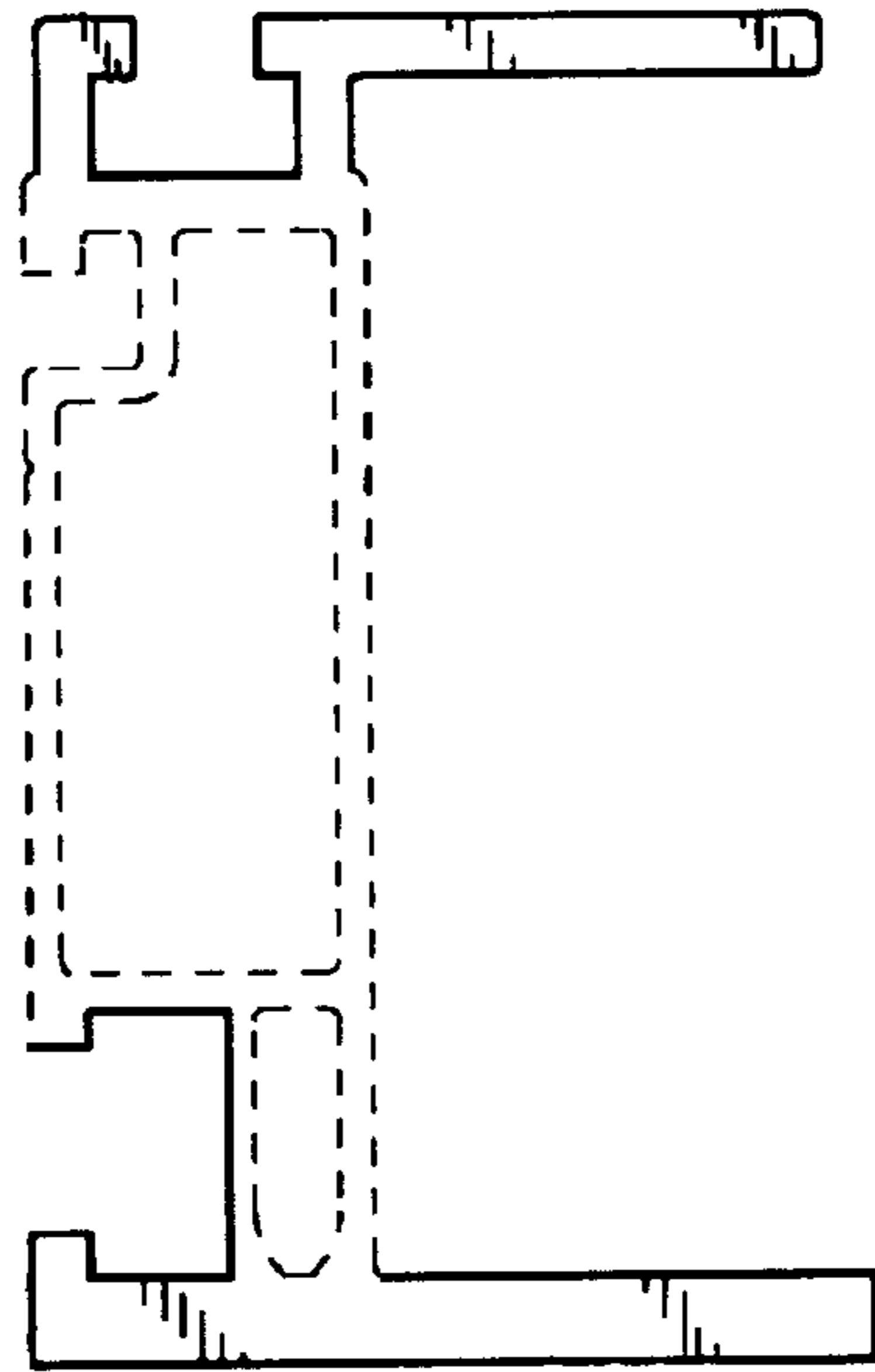

FIG.4

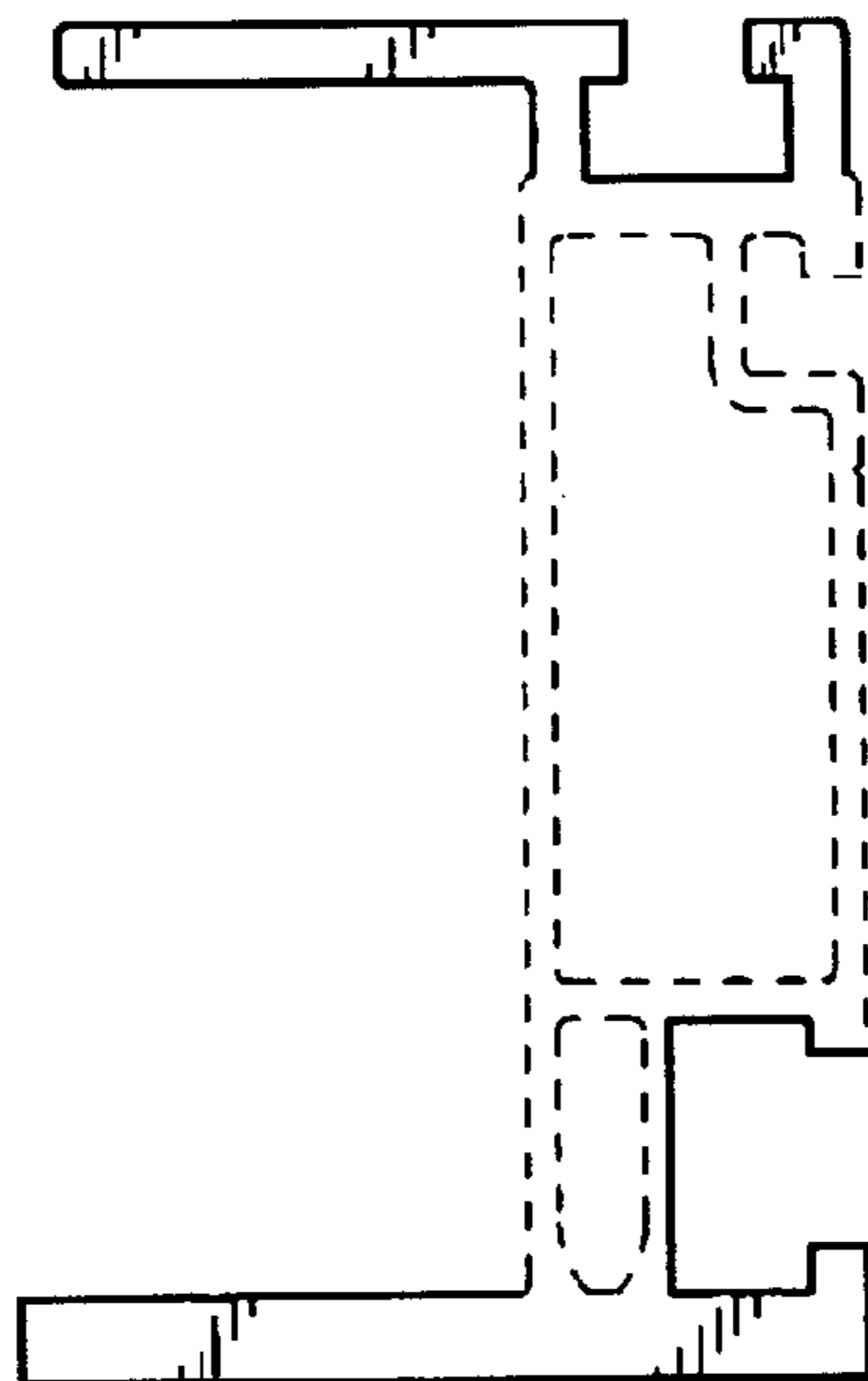

FIG.5

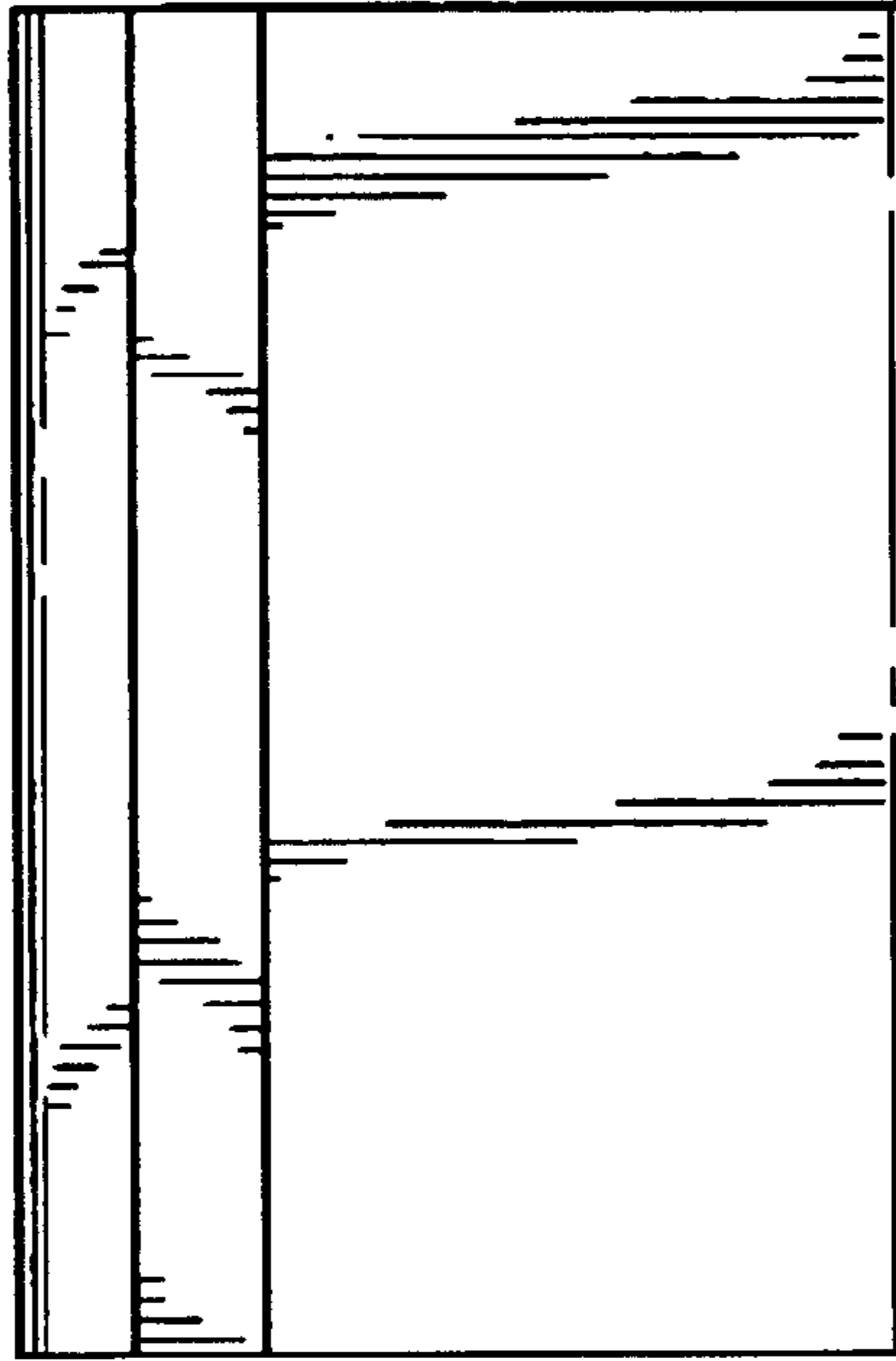

FIG.6

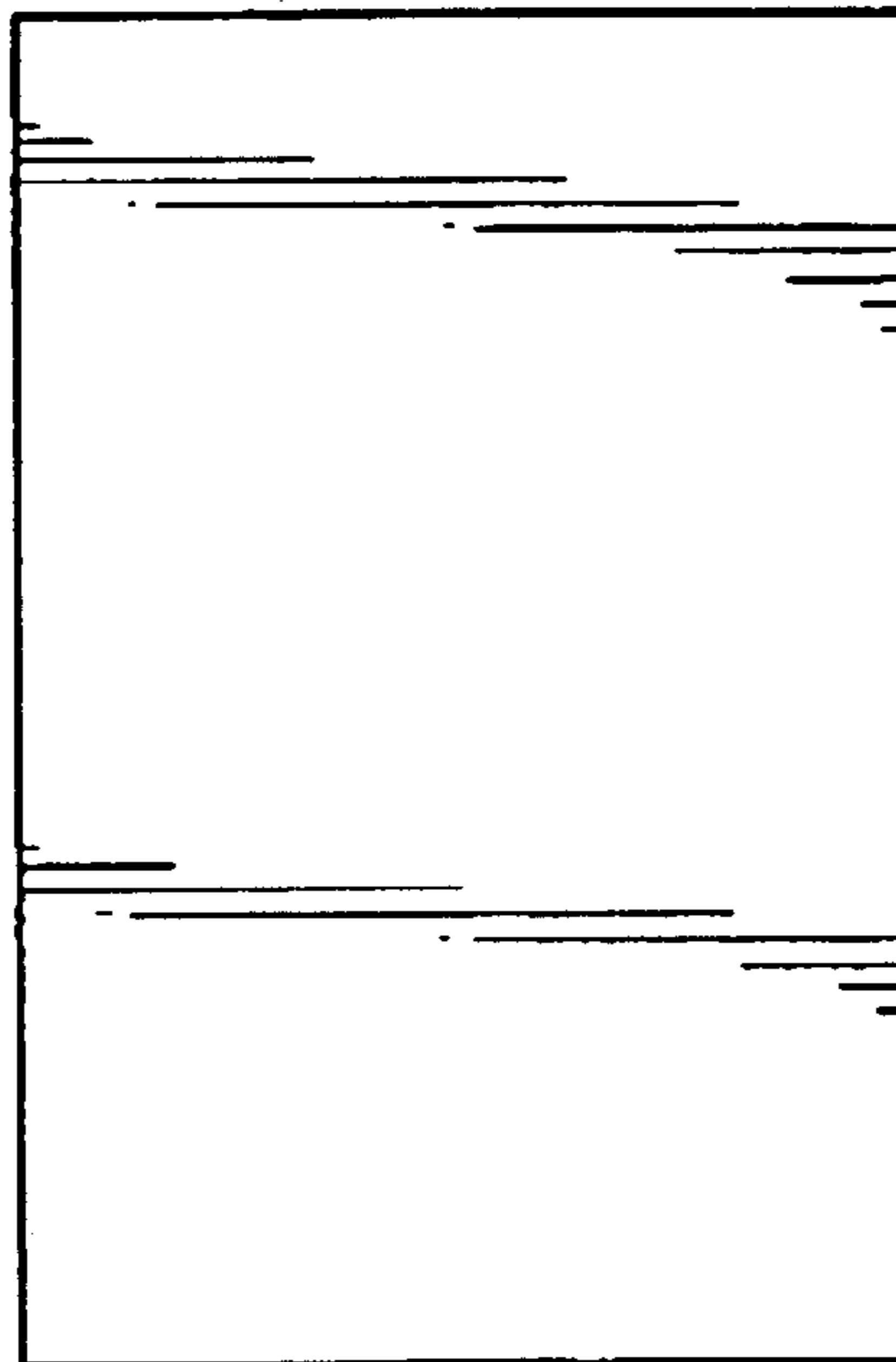

FIG.7