

US00D496248S1

(12) **United States Design Patent** (10) **Patent No.:** **US D496,248 S**
Liebendorfer (45) **Date of Patent:** **** Sep. 21, 2004**

(54) **MODIFIED STANDARD RAIL**

(75) Inventor: **John E. Liebendorfer**, Albuquerque, NM (US)

(73) Assignee: **UNIRAC, Inc.**, Albuquerque, NM (US)

(**) Term: **14 Years**

(21) Appl. No.: **29/177,274**

(22) Filed: **Aug. 18, 2003**

(51) **LOC (7) Cl.** **08-05**

(52) **U.S. Cl.** **D8/354**

(58) **Field of Search** D8/349, 354, 373, D8/376, 380; D25/119, 120, 121, 122, 123, 124, 125; 52/720.1, 724.1, 726.1, 730.1, 731.1, 737.1; 428/36.9, 122

(56) **References Cited**

U.S. PATENT DOCUMENTS

D261,311 S	*	10/1981	Schmidt	D25/124
D330,264 S	*	10/1992	Valentin	D25/124
D357,077 S	*	4/1995	Franson	D25/124
D431,658 S	*	10/2000	Gregori	D25/122
D469,886 S	*	2/2003	Barnett	D25/119
D471,286 S	*	3/2003	Roberts et al.	D25/60
6,668,500 B1	*	12/2003	Lamberts	52/204.72

* cited by examiner

Primary Examiner—Joel Sincavage
Assistant Examiner—Elizabeth Albert
(74) *Attorney, Agent, or Firm*—Ray R. Regan

(57) **CLAIM**

The ornamental design for the modified standard rail, as shown and described.

DESCRIPTION

FIG. 1 is a perspective view of the Invention showing the new design;
FIG. 2 is a right side elevational view of the Invention shown in FIG. 1;
FIG. 3 is a left side elevational view of the Invention shown in FIG. 1;
FIG. 4 is a front elevational view of the Invention shown in FIG. 1;
FIG. 5 is a rear elevational view of the Invention shown in FIG. 1;
FIG. 6 is a top plan view of the Invention shown in FIG. 1; and,
FIG. 7 is a bottom plan view of the Invention shown in FIG. 1.
The broken lines showing environment in the drawing are for illustrative purposes only, and form no part of the claimed design.

1 Claim, 3 Drawing Sheets

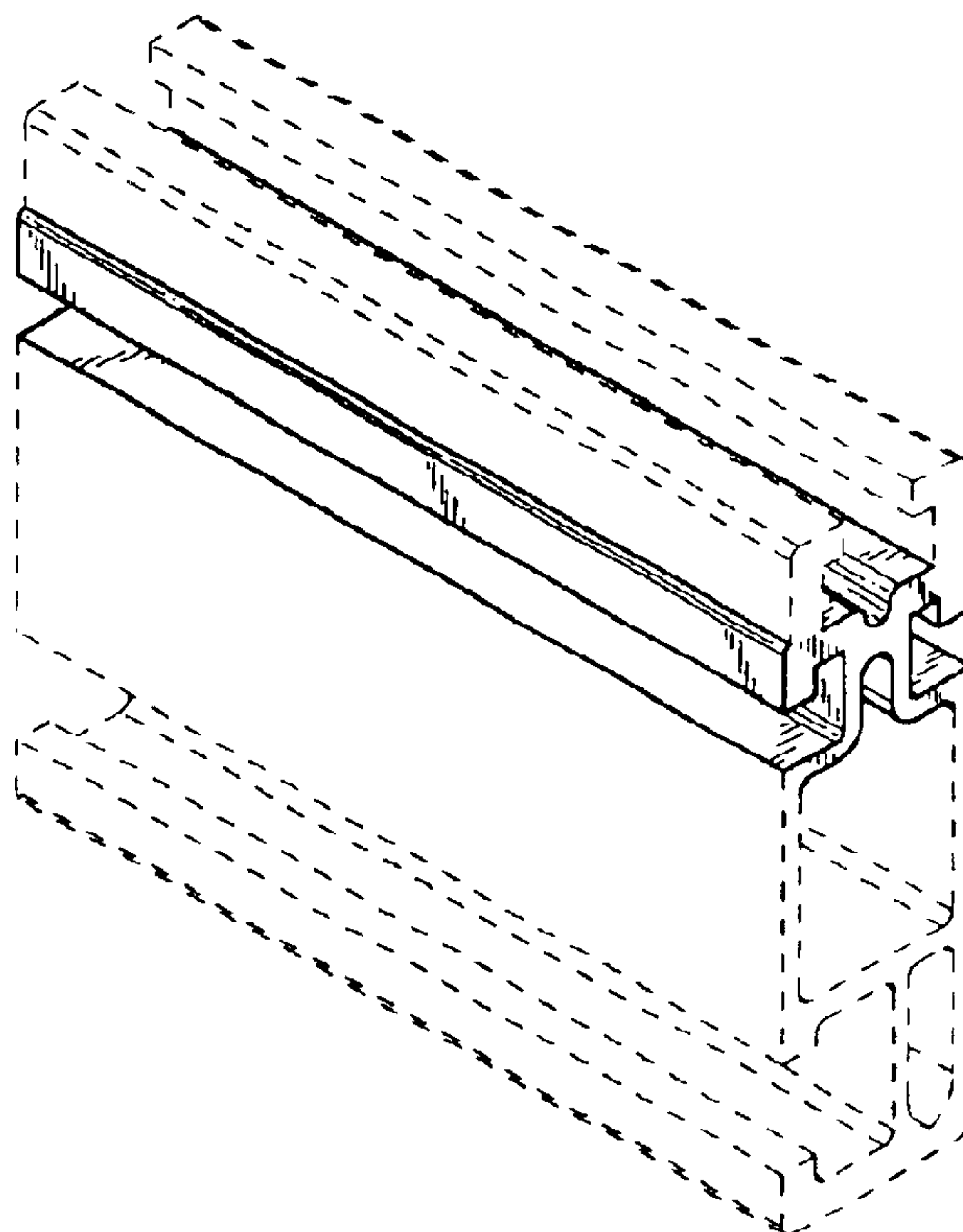

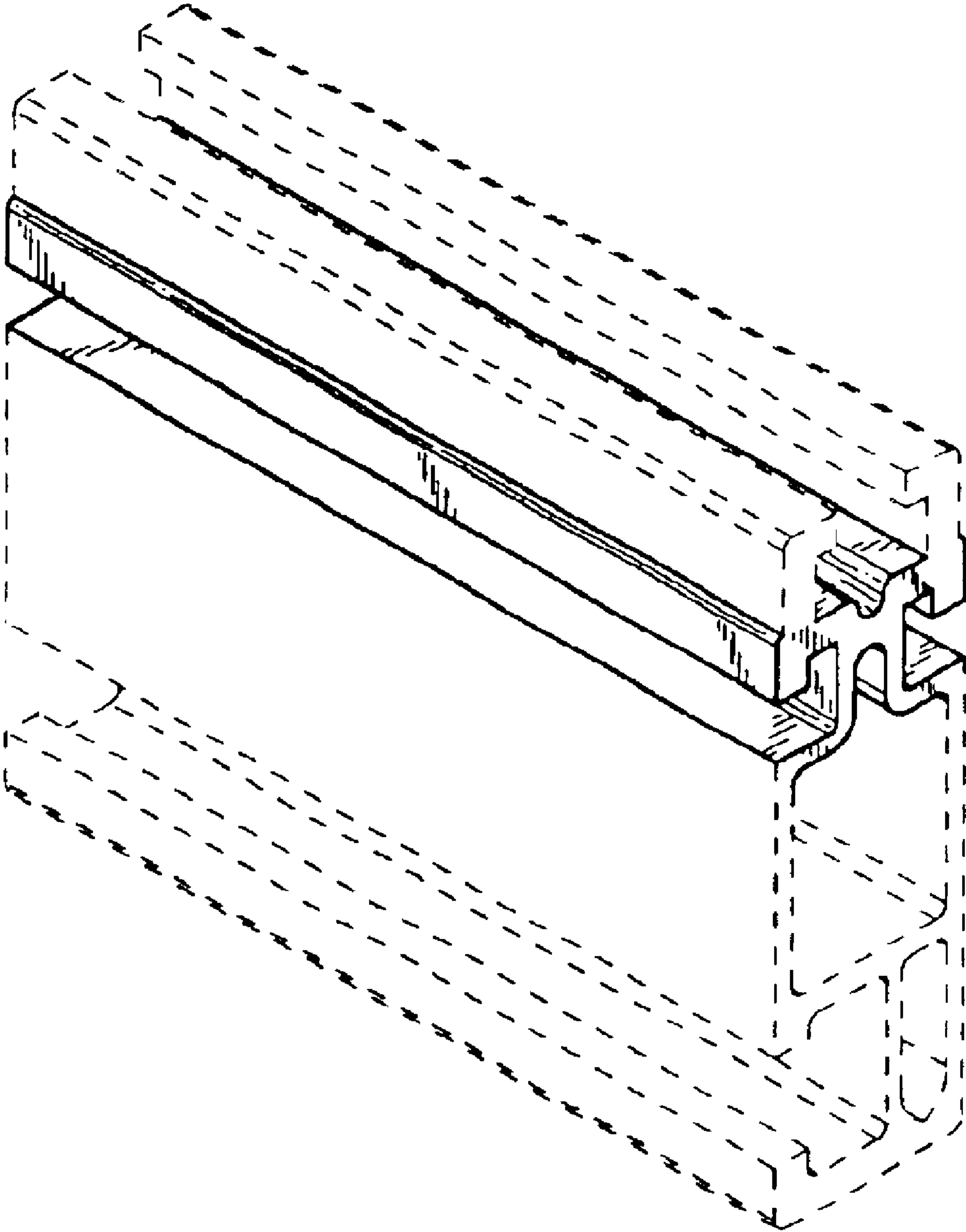

FIG. 1

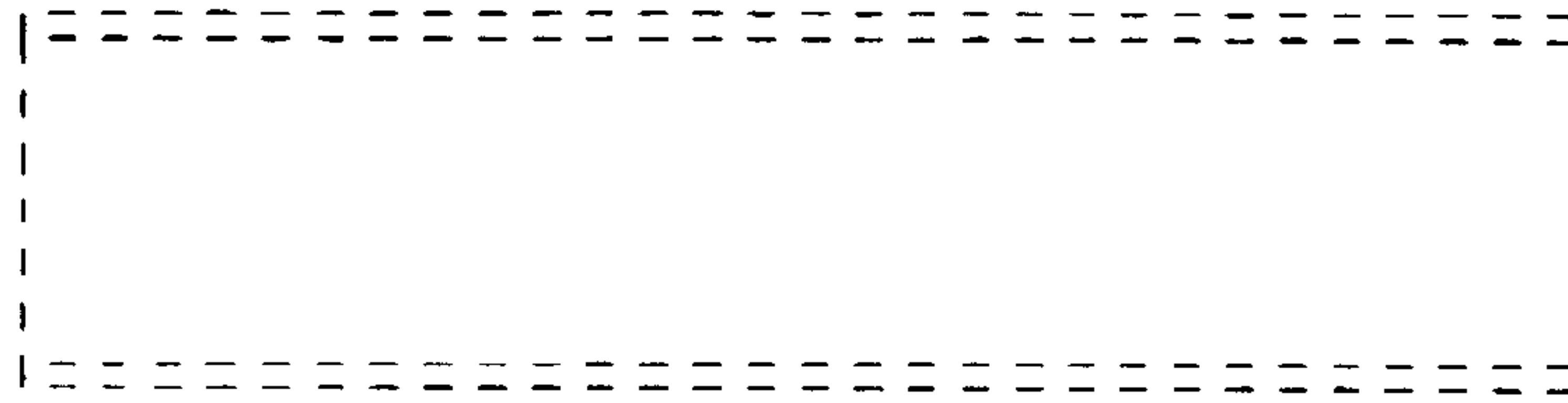

FIG. 2

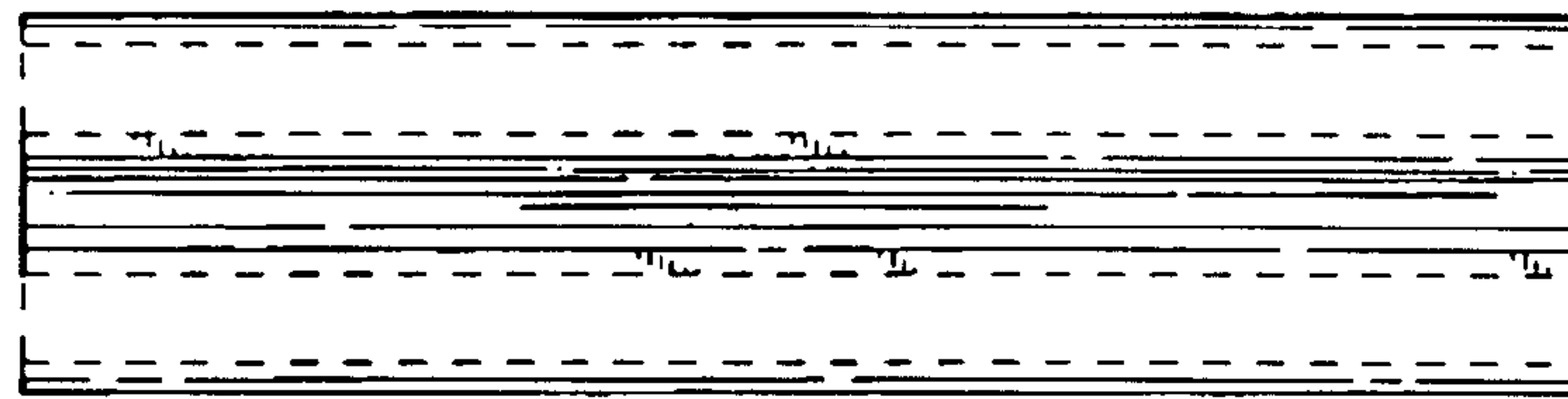

FIG. 3

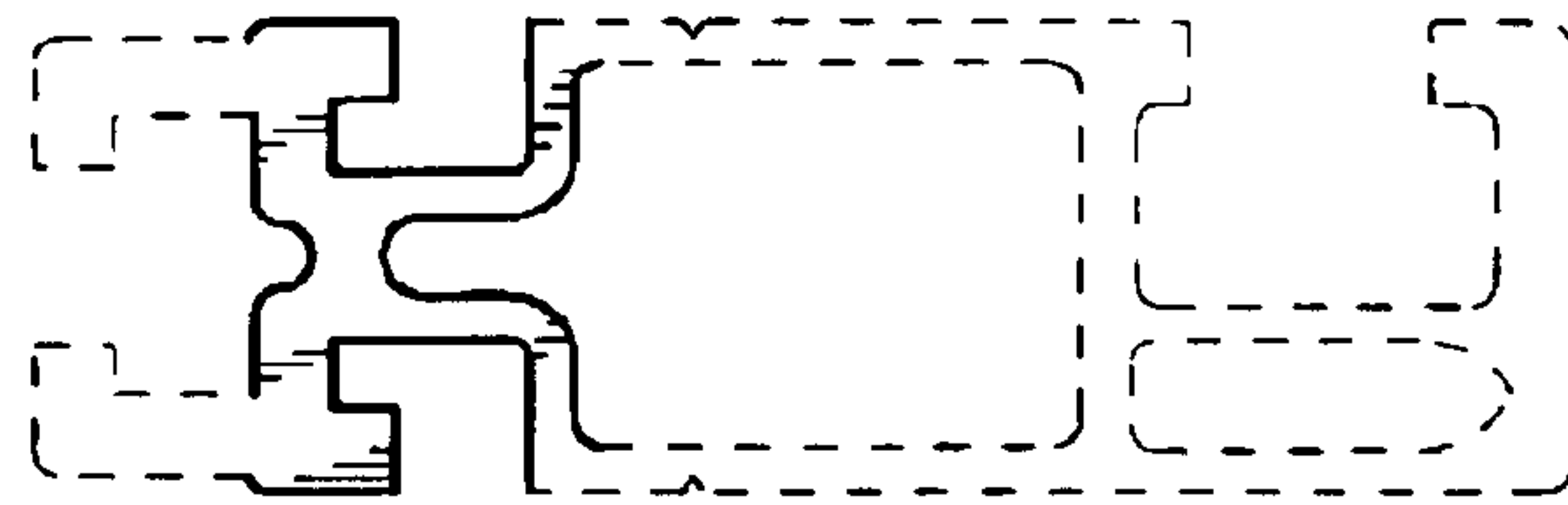

FIG. 4

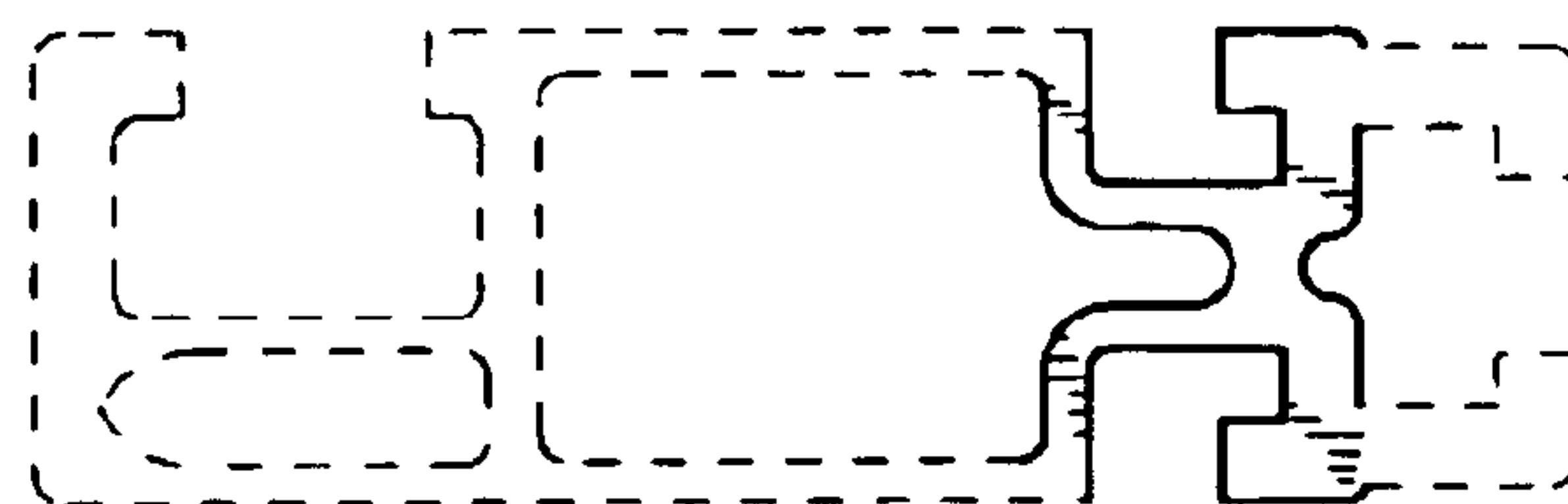

FIG. 5

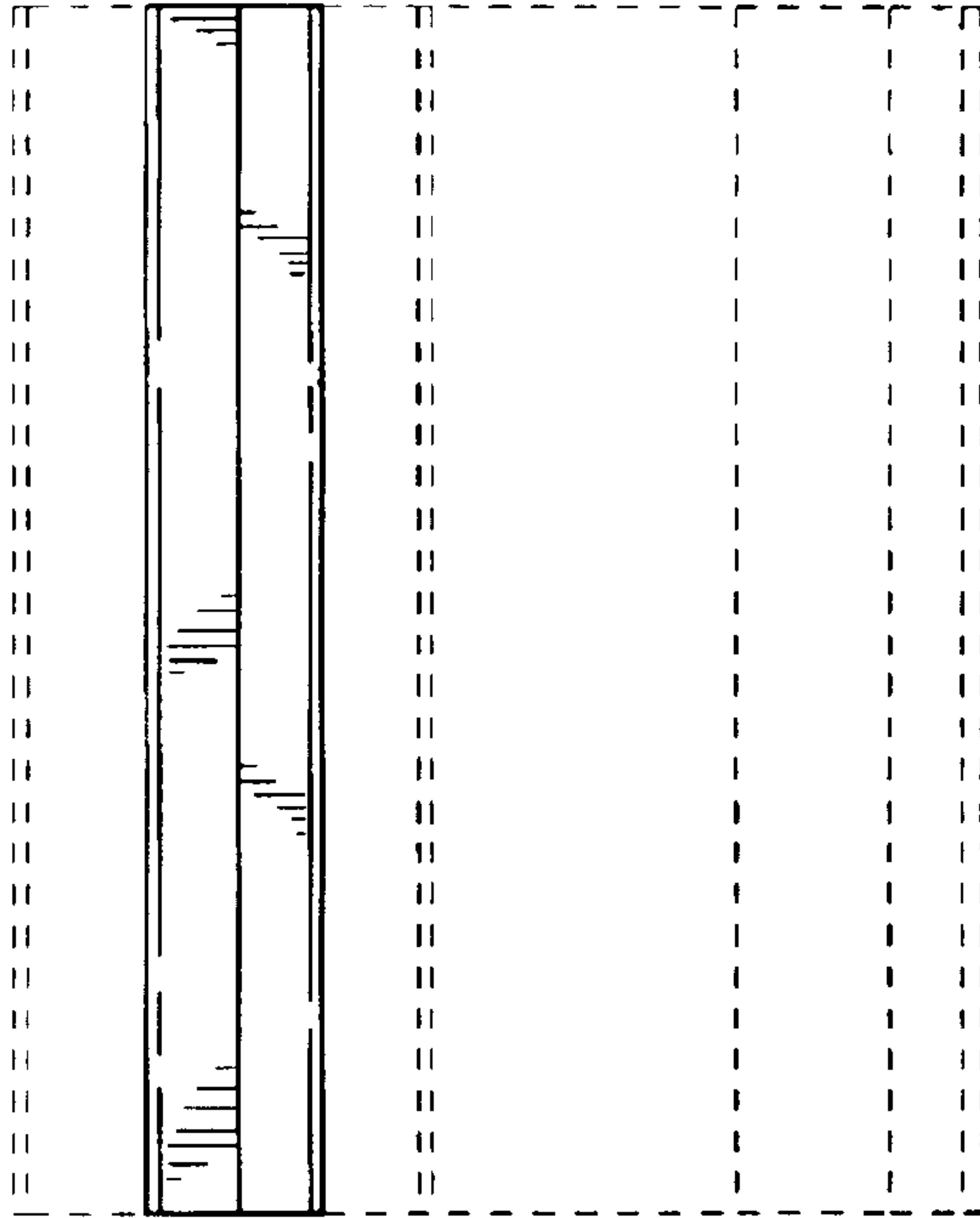

FIG. 6

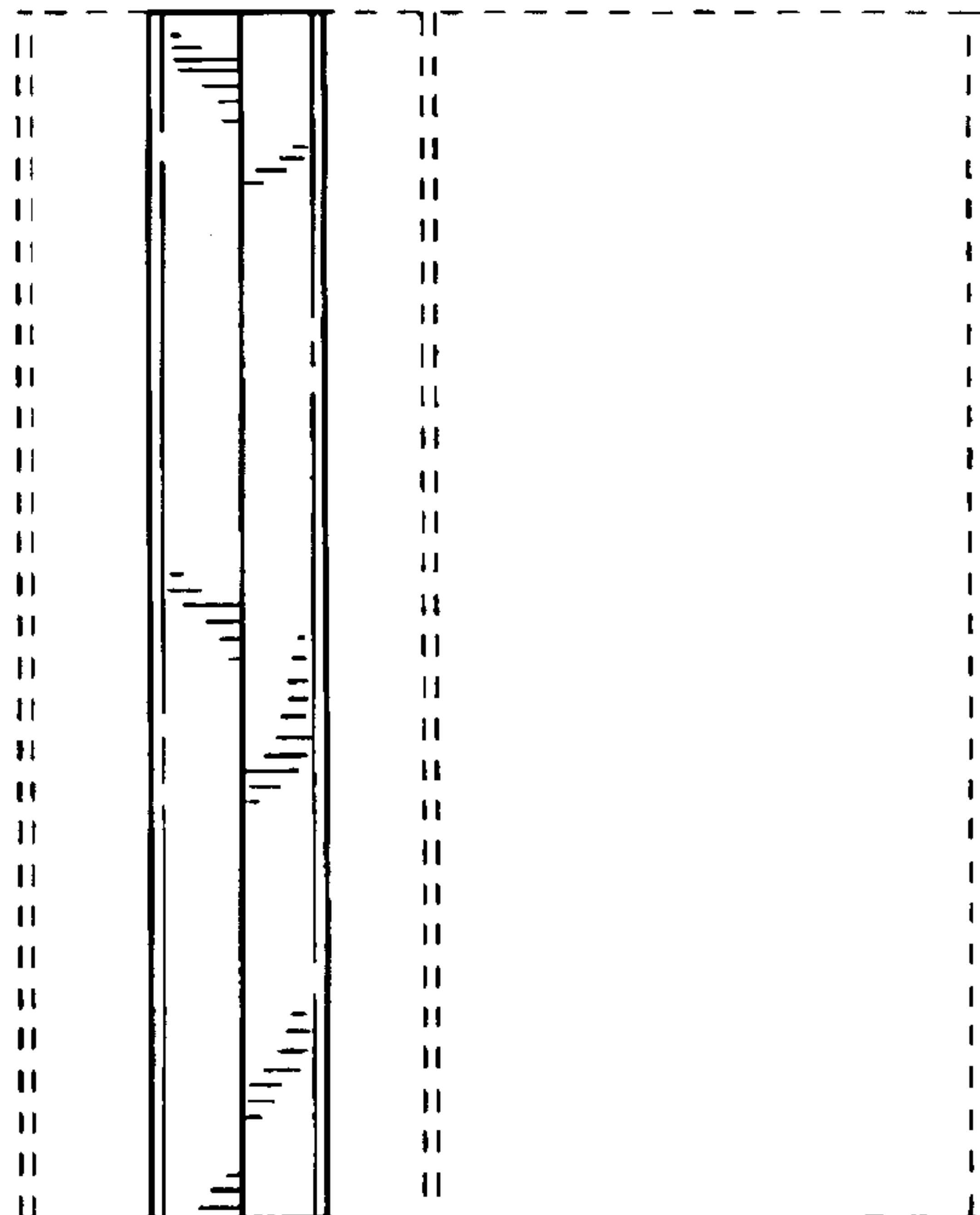

FIG. 7