

US00D495653S1

(12) **United States Design Patent** (10) **Patent No.:** **US D495,653 S**
Eatkins et al. (45) **Date of Patent:** **** Sep. 7, 2004**

(54) **JET AIRPLANE**

(75) Inventors: **Mark Eatkins**, Kirkland, WA (US);
Paul Dees, Woodinville, WA (US);
Blake Emery, Enumclaw, WA (US);
Chris B. Kettering, Kirkland, WA
(US); **Kevin Retz**, Bothell, WA (US);
Paul Mikulencak, Everett, WA (US)

(73) Assignee: **The Boeing Company**, Chicago, IL
(US)

(**) Term: **14 Years**

(21) Appl. No.: **29/187,466**

(22) Filed: **Aug. 1, 2003**

Related U.S. Application Data

(62) Division of application No. 29/181,153, filed on May 5,
2003.

(51) **LOC (7) Cl.** **12-99**

(52) **U.S. Cl.** **D12/319**

(58) **Field of Search** D12/319-345;
244/45 A, 45 R, 13, 15, 91, 198, 211, 218

(56) **References Cited**

U.S. PATENT DOCUMENTS

D354,474 S * 1/1995 Murphy et al. D12/319
D370,456 S * 6/1996 Buchsel et al. D12/319
D379,989 S * 6/1997 Skene et al. D14/214
D426,804 S * 6/2000 Birrenbach D12/319
D451,879 S * 12/2001 Fraser D12/319

OTHER PUBLICATIONS

Pamphlet: Plane Spotter: Your Guide to Passenger Airlines
© 1999.

Bill Yenne, The Story of the Boeing Company, AGS Book-
Works, San Francisco, CA © 2003.

* cited by examiner

Primary Examiner—Marcus A. Jackson

(57) **CLAIM**

The ornamental design for a jet airplane, as shown and
described.

DESCRIPTION

FIG. 1 is a perspective view of the inventive jet airplane;
FIG. 2 is a top plan view of the jet airplane;
FIG. 3 is a front plan view of the jet airplane;
FIG. 4 is a back plan view of the jet airplane;
FIG. 5 is a view of one side of the jet airplane, with the
opposite side being a mirror image thereof;
FIG. 6 is a bottom plan view of the jet airplane;
FIG. 7 is a perspective view of a second embodiment of the
inventive jet airplane;
FIG. 8 is a top plan view of a second embodiment of the
inventive jet airplane;
FIG. 9 is a front plan view of a second embodiment of the
inventive jet airplane;
FIG. 10 is a back plan view of a second embodiment of the
inventive jet airplane;
FIG. 11 is a view of one side of a second embodiment of the
inventive jet airplane, with the opposite side being a mirror
image thereof; and,
FIG. 12 is a bottom plan view of a second embodiment of
the inventive jet airplane.

1 Claim, 10 Drawing Sheets

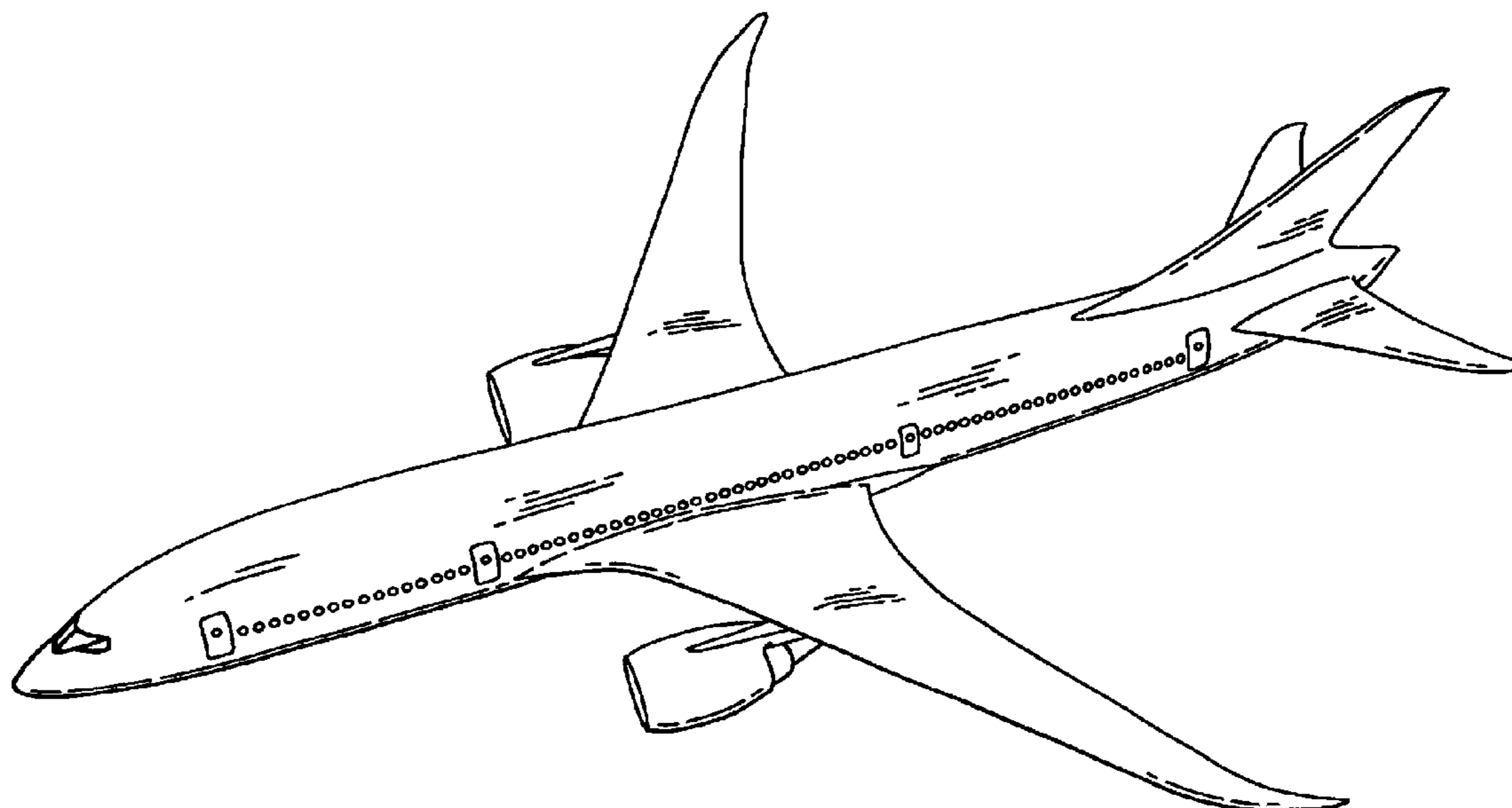

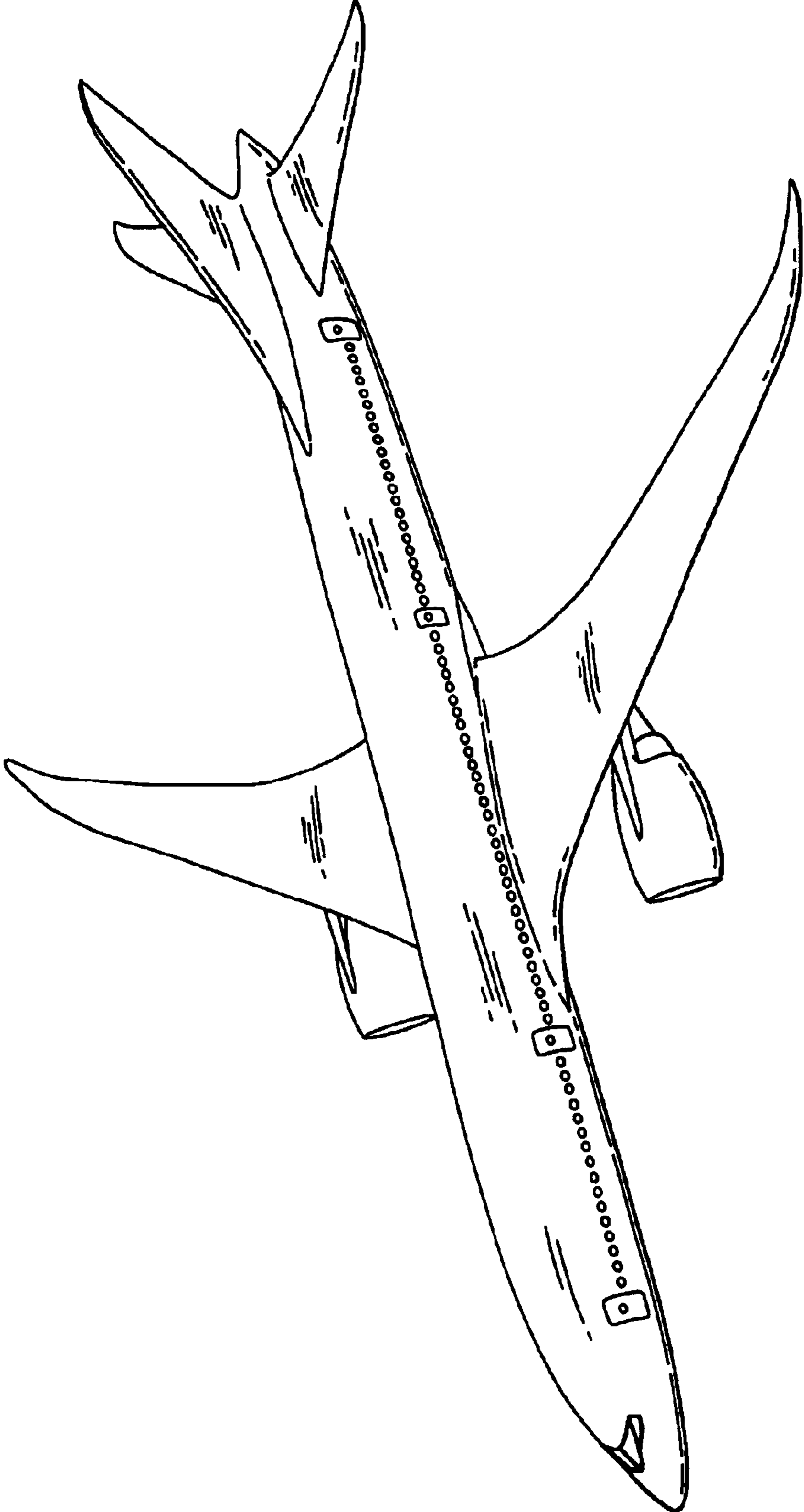

FIG. 1

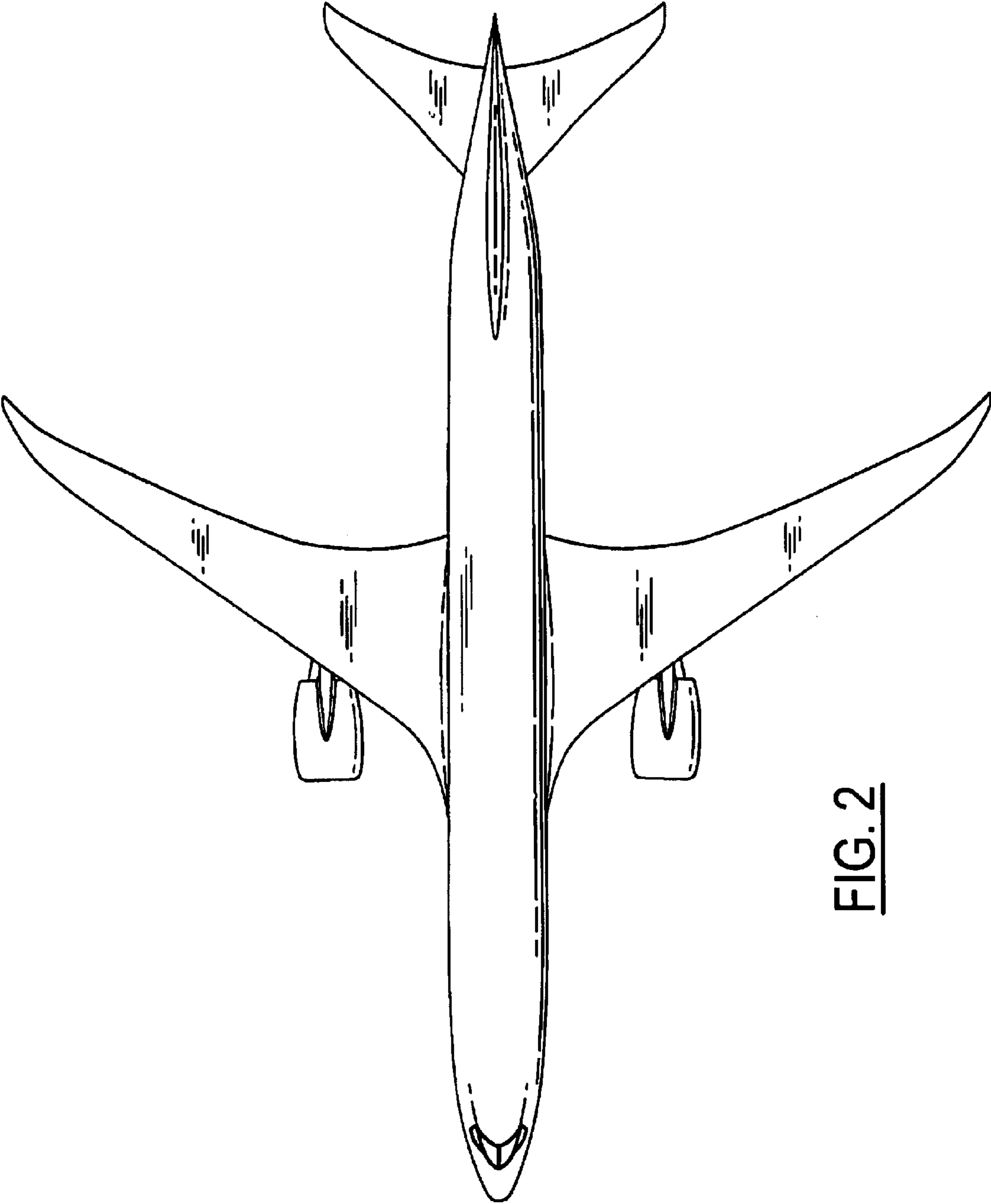

FIG. 2

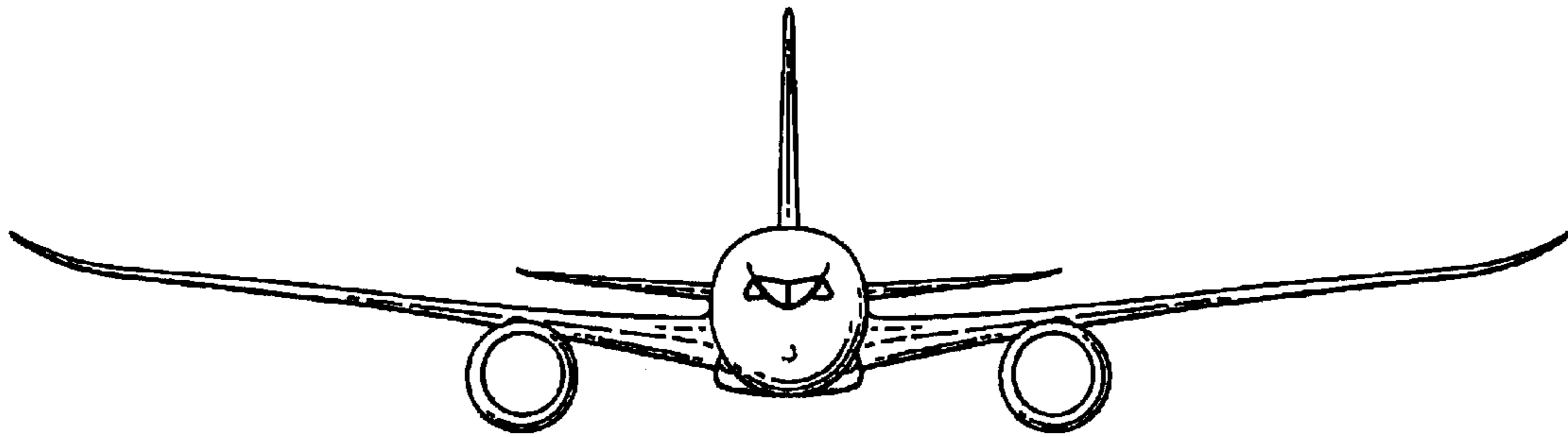

FIG. 3

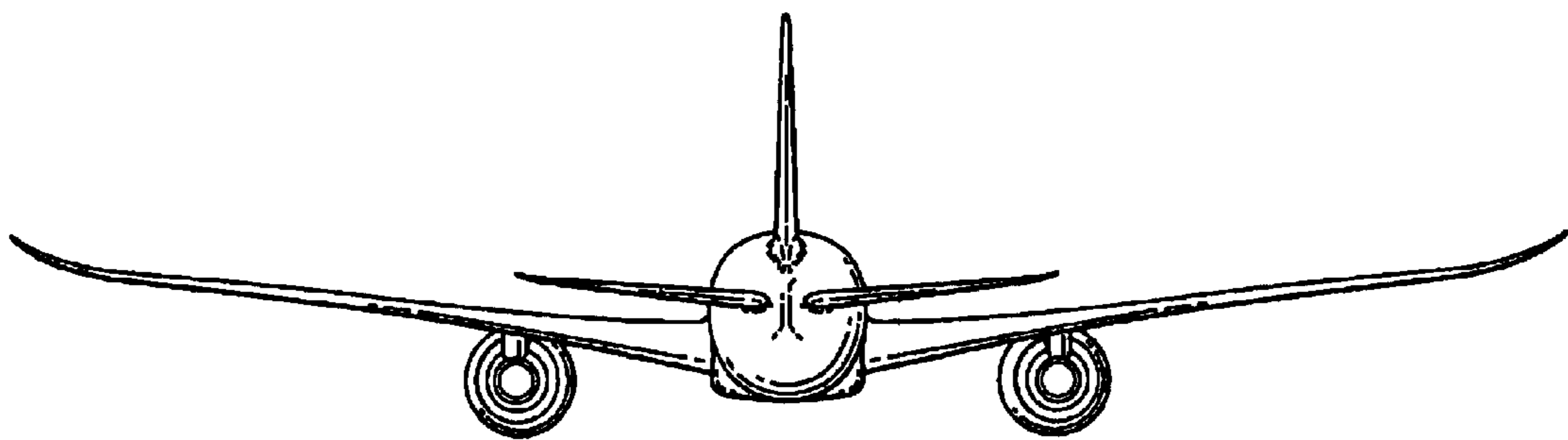

FIG. 4

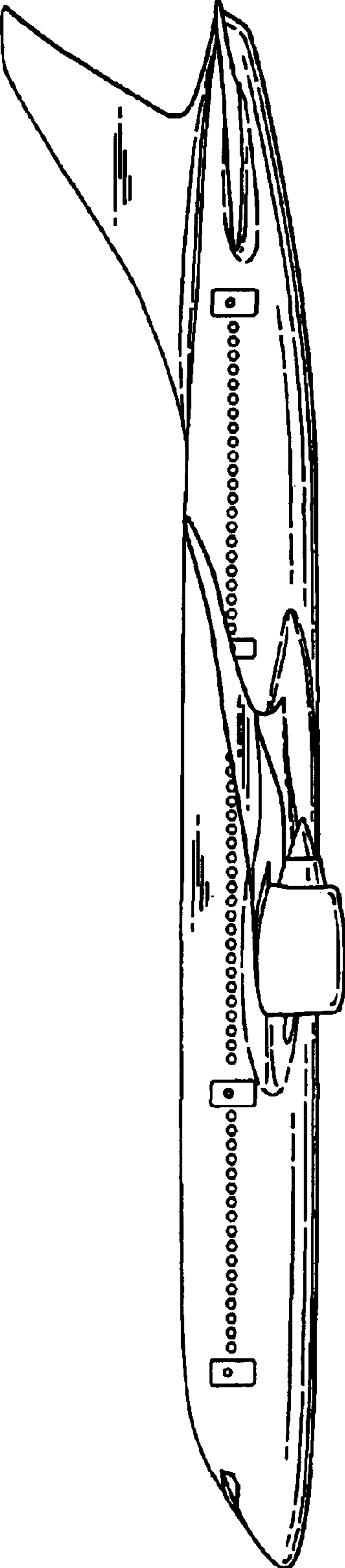

FIG. 5

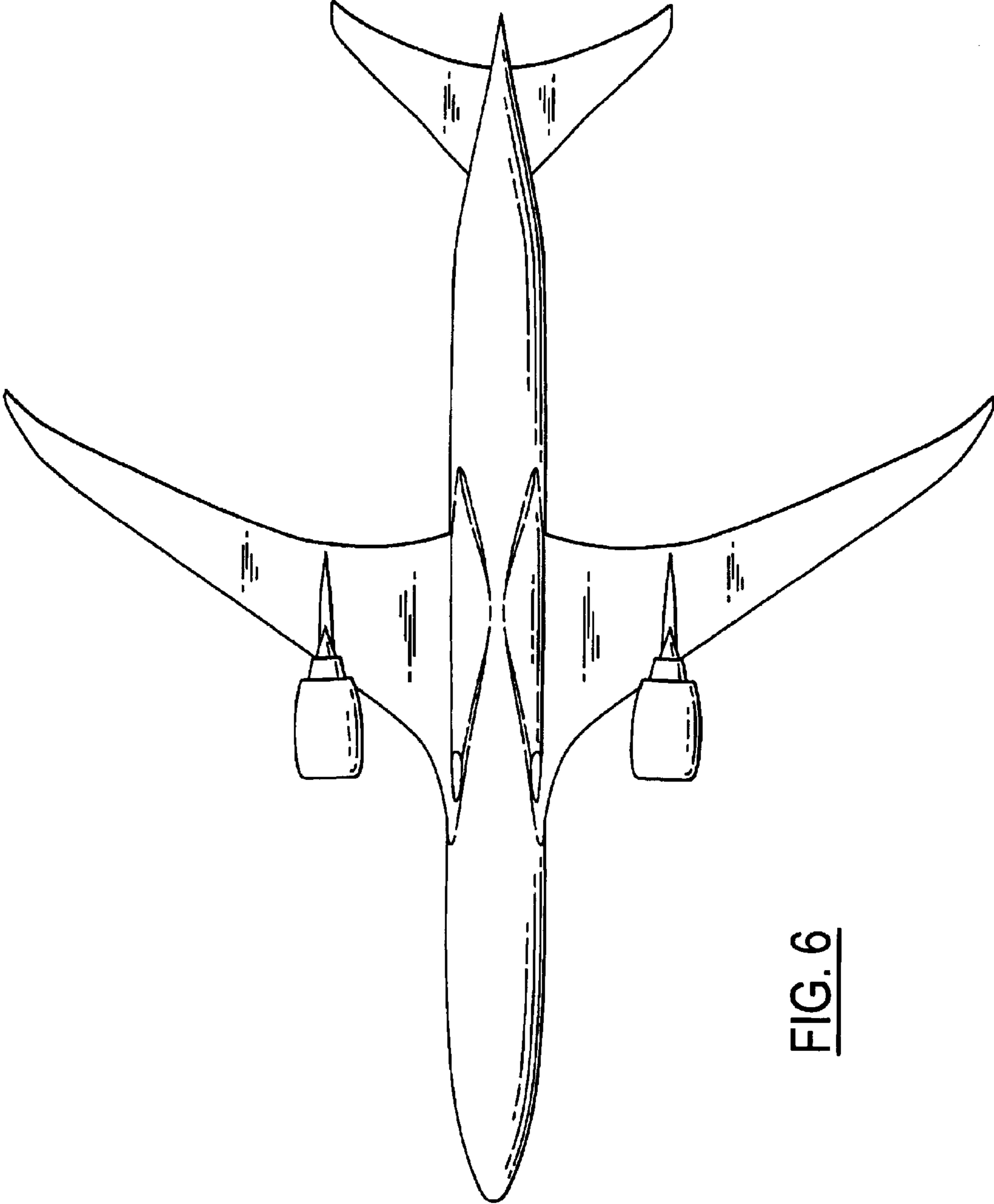

FIG. 6

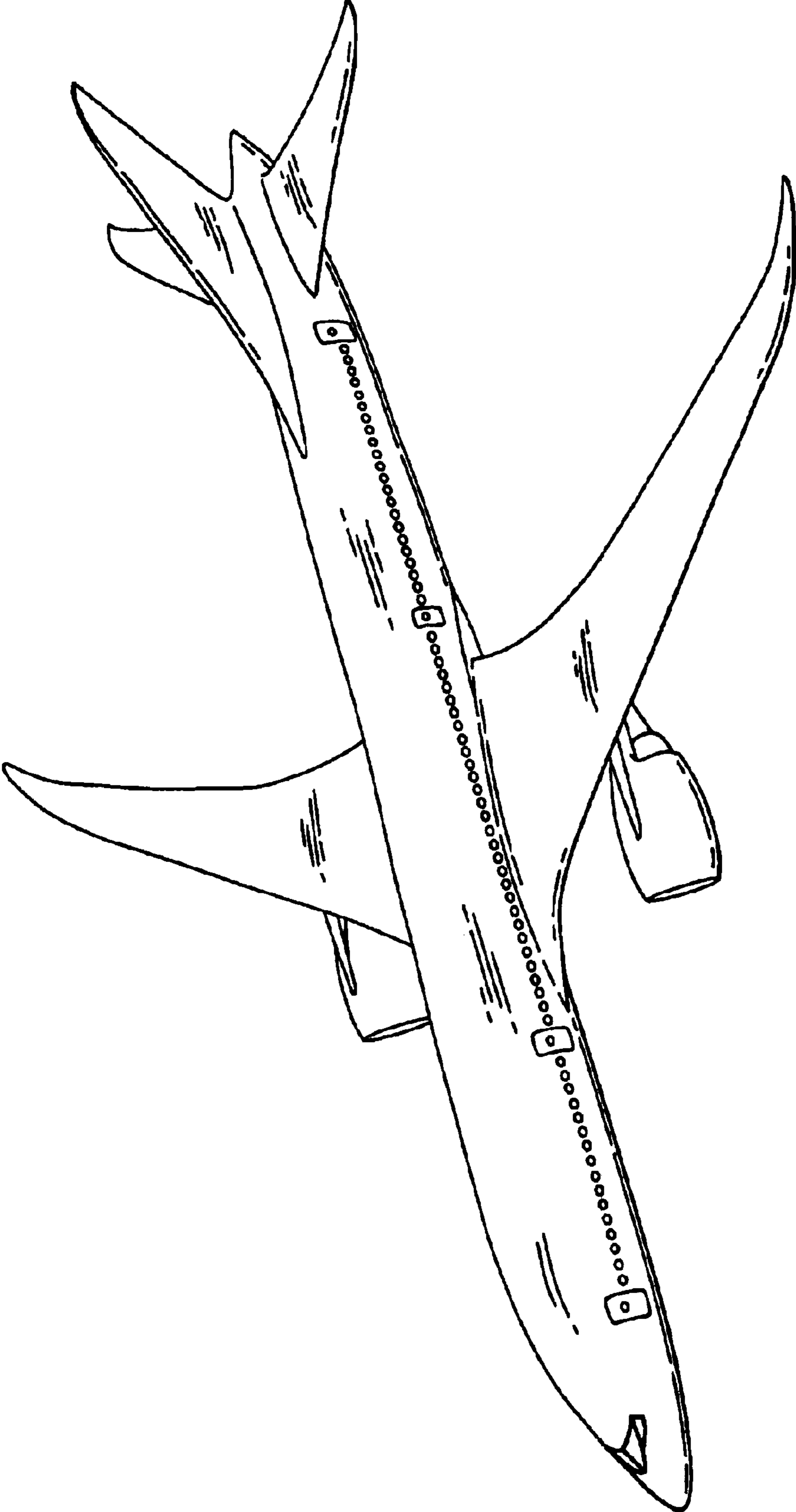

FIG. 7

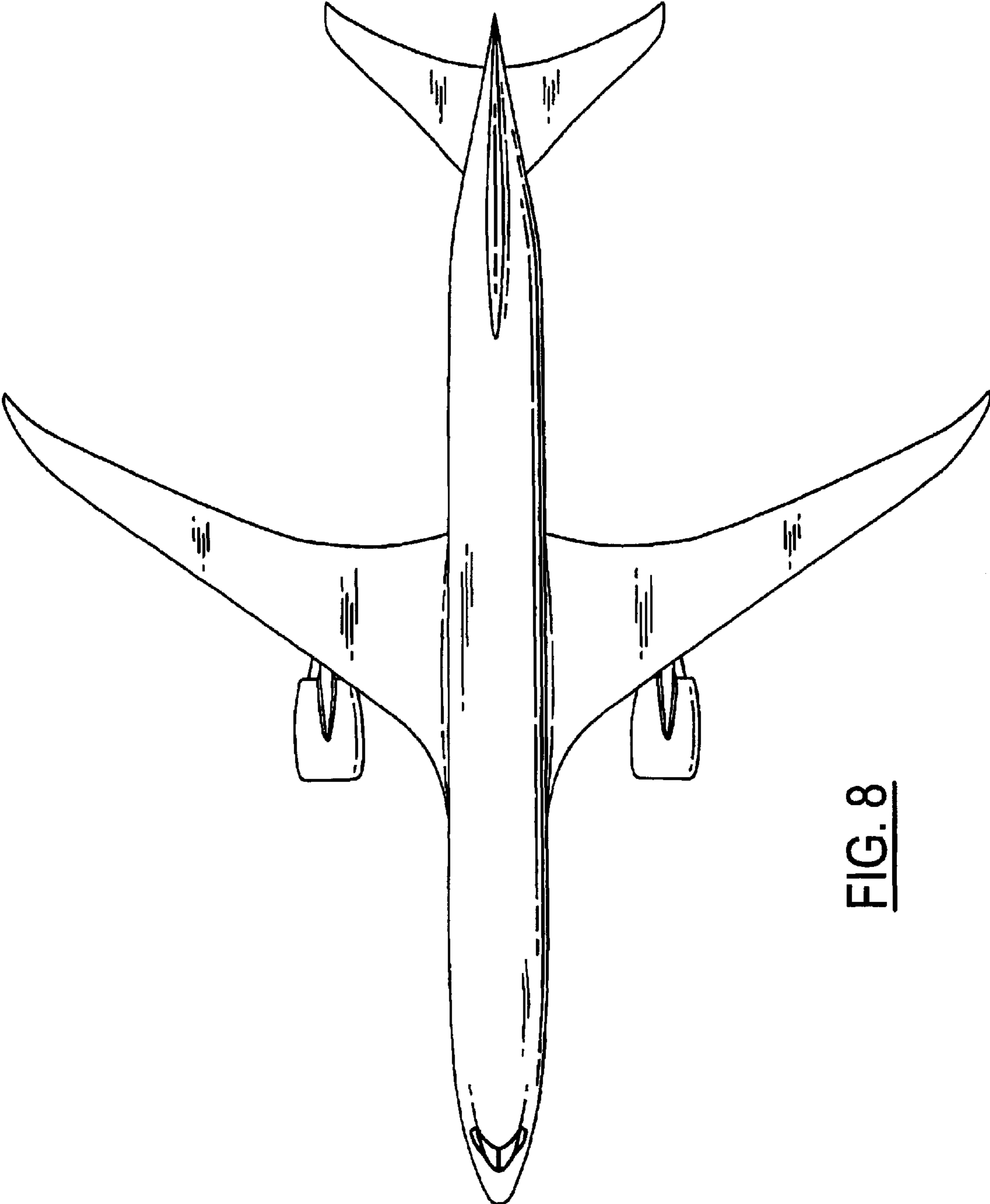

FIG. 8

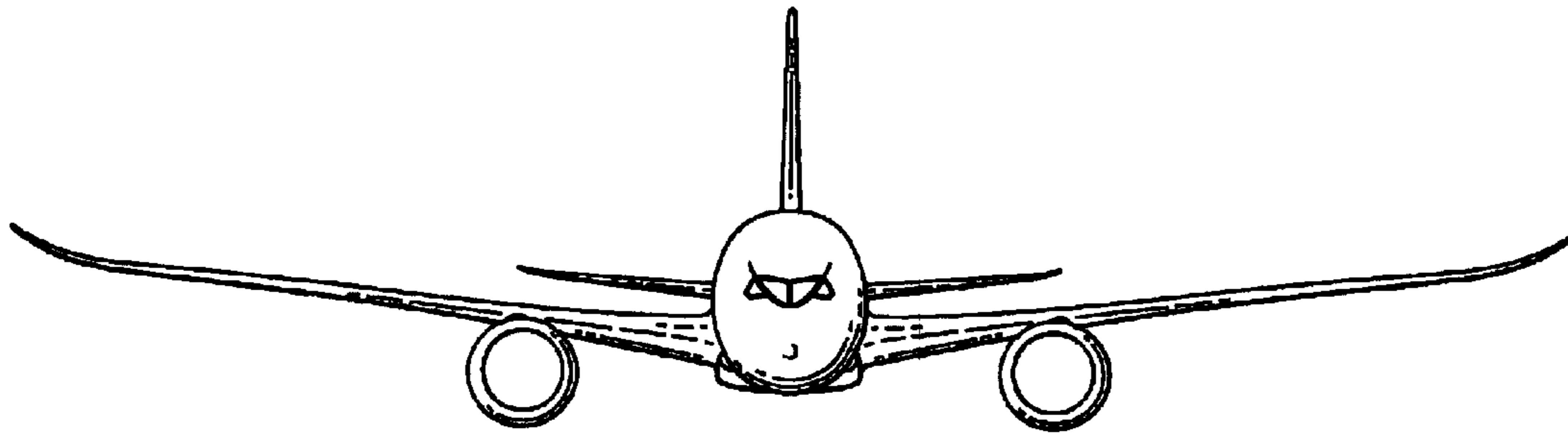

FIG. 9

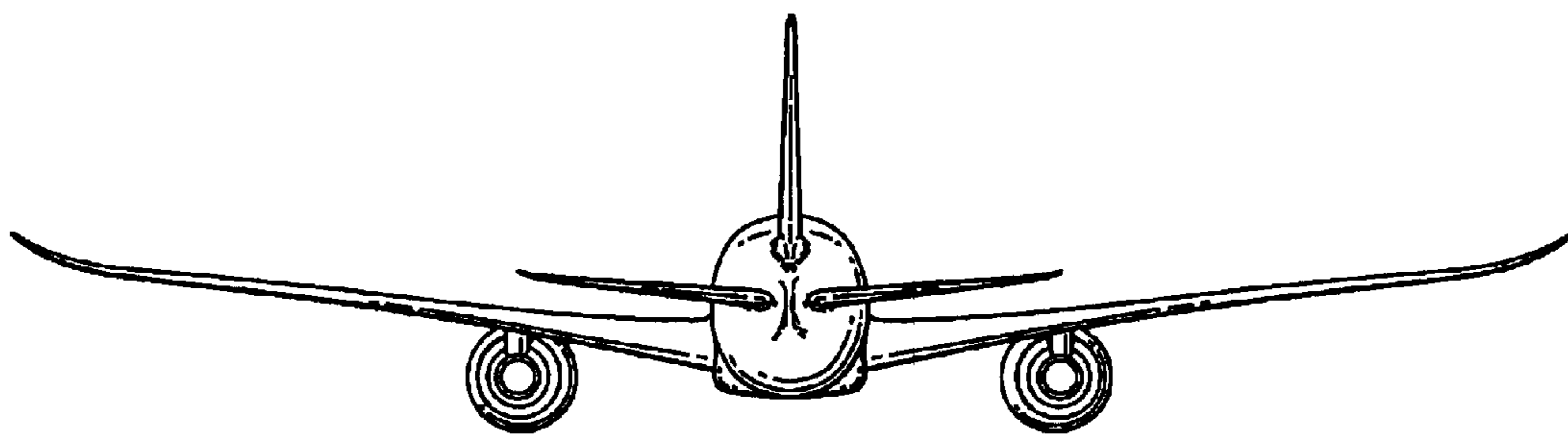

FIG. 10

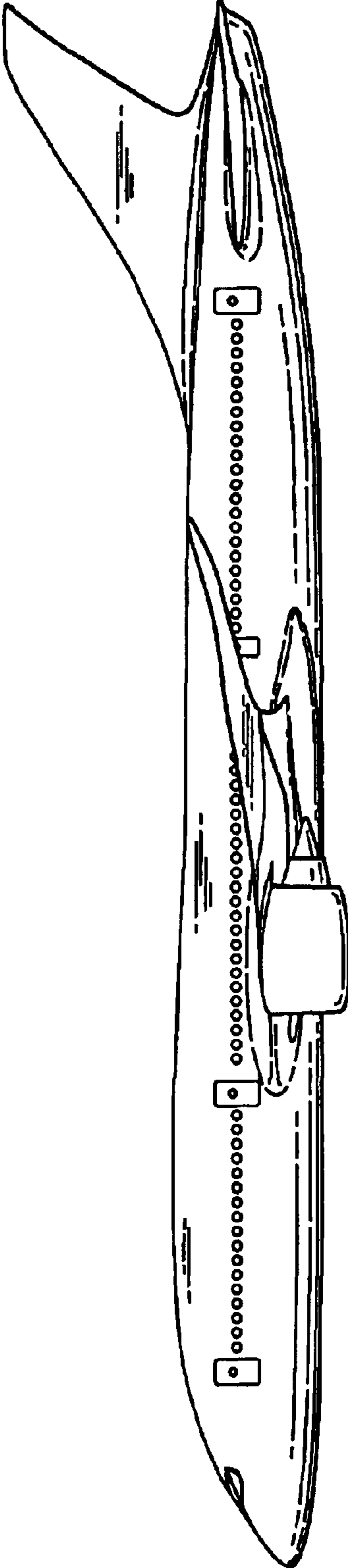

FIG. 11

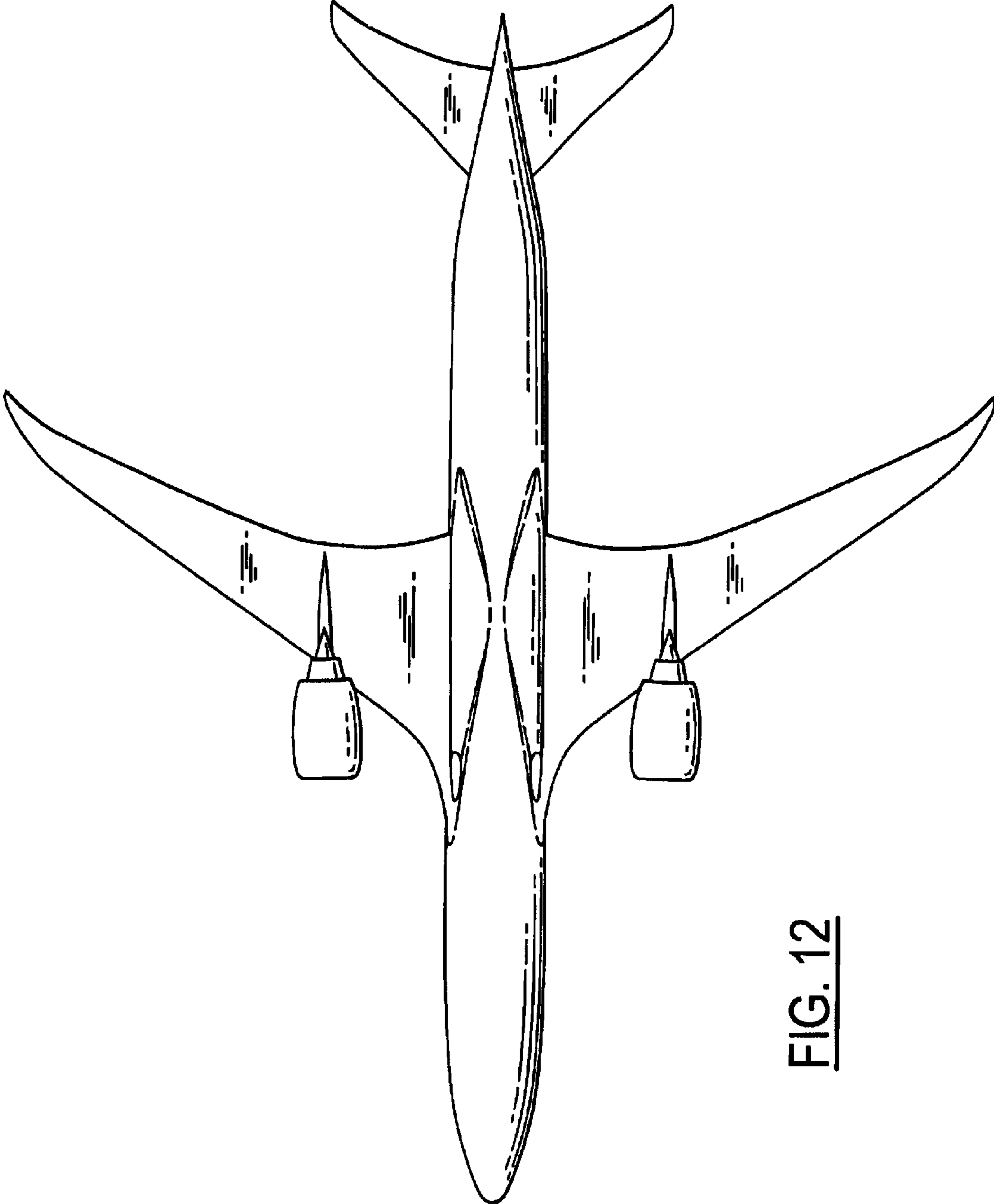

FIG. 12