



US00D495645S1

(12) **United States Design Patent**  
**Hall et al.**

(10) **Patent No.:** **US D495,645 S**  
(45) **Date of Patent:** **\*\* Sep. 7, 2004**

(54) **VEHICLE SIDE LINING**

D478,854 S \* 8/2003 Platto et al. .... D12/196

(75) Inventors: **Jarad W. Hall**, Manhattan Beach, CA (US); **Donald Lariviere**, Whittier, CA (US); **Thomas H. Kim**, Reseda, CA (US)

\* cited by examiner

*Primary Examiner*—Melody N. Brown  
(74) *Attorney, Agent, or Firm*—Plumsea Law Group, LLC

(73) Assignee: **Honda Motor Co., Ltd.**, Tokyo (JP)

(57) **CLAIM**

(\*\*) Term: **14 Years**

The ornamental design for a vehicle side lining, as shown and described.

(21) Appl. No.: **29/190,106**

**DESCRIPTION**

(22) Filed: **Sep. 16, 2003**

(51) **LOC (7) Cl.** ..... **12-16**

(52) **U.S. Cl.** ..... **D12/196**

(58) **Field of Search** ..... D12/196, 90-92,  
D12/96, 97, 190; 296/185, 57.1, 183, 190;  
180/89.1, 89.11, 89.12

FIG. 1 is a perspective view of a right-handed vehicle side lining showing our new design;

FIG. 2 is a top plan view thereof;

FIG. 3 is a front elevational view thereof;

FIG. 4 is a cross-sectional view taken along line 4-4 in FIG. 3;

FIG. 5 is a perspective view of a left-handed vehicle side lining, a mirror image of the side lining of FIG. 1;

FIG. 6 is a top plan view of FIG. 5;

FIG. 7 is a front elevational view of FIG. 5; and,

FIG. 8 is a cross-sectional view taken along line 8-8 in FIG. 7.

The broken line showings of the connection apertures and connection hardware are for illustrative purposes only and form no part of the claimed invention.

(56) **References Cited**

**U.S. PATENT DOCUMENTS**

- D413,561 S \* 9/1999 Kulla et al. .... D12/190
- D418,100 S \* 12/1999 Sacco et al. .... D12/196
- D420,622 S \* 2/2000 Hellhake et al. .... D12/97
- D433,981 S \* 11/2000 Davis et al. .... D12/196
- D455,990 S \* 4/2002 Mobius ..... D12/196
- D468,671 S \* 1/2003 Tampi ..... D12/190

**1 Claim, 4 Drawing Sheets**

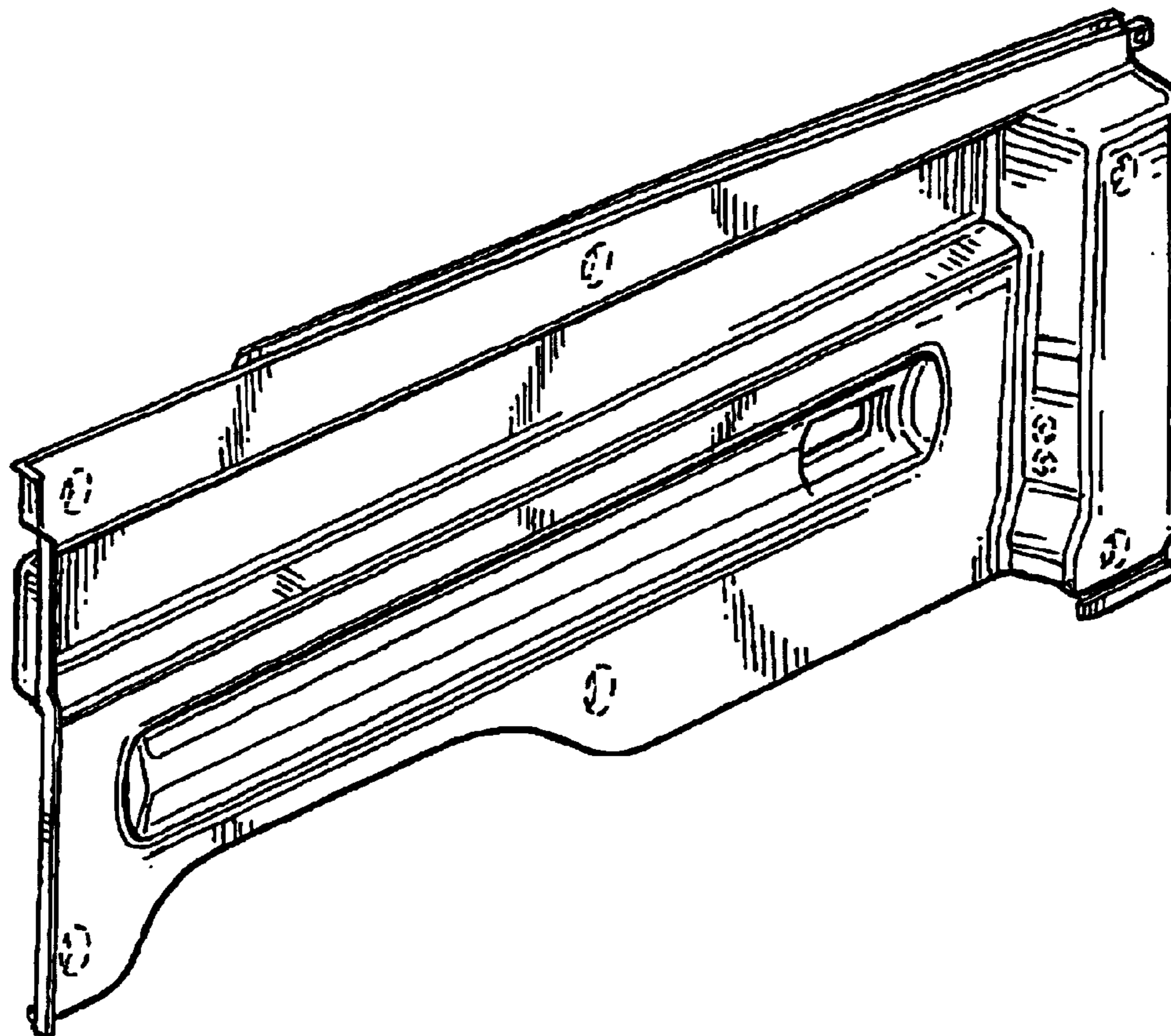

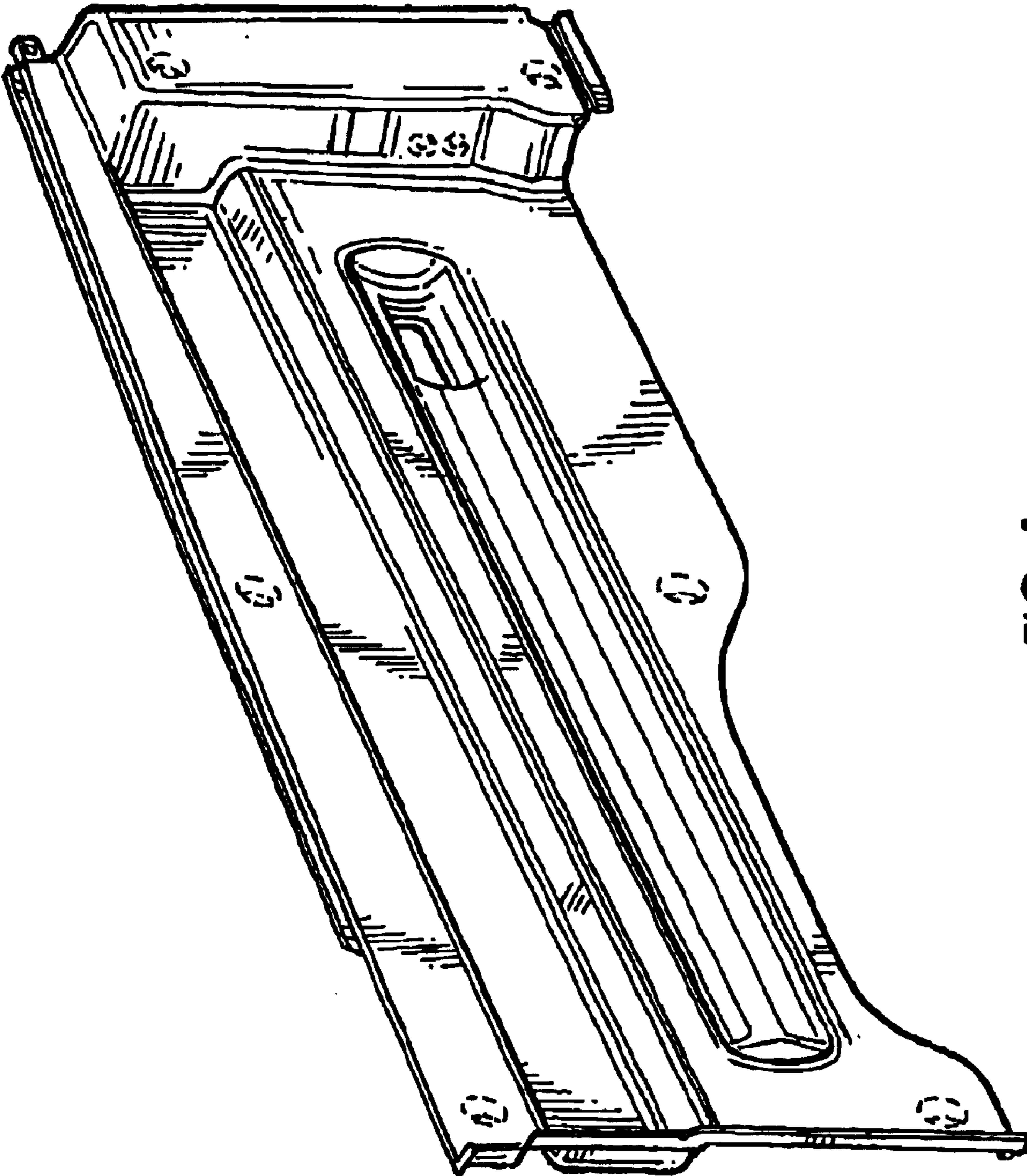

FIG. 1

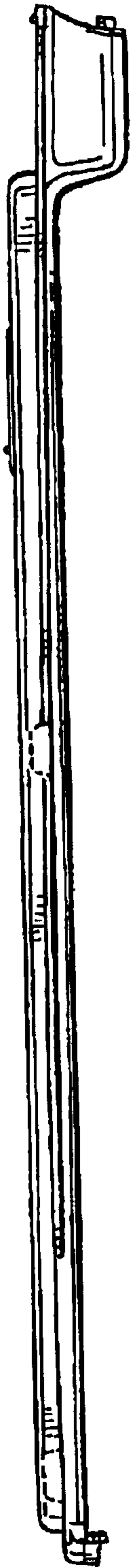

FIG. 2

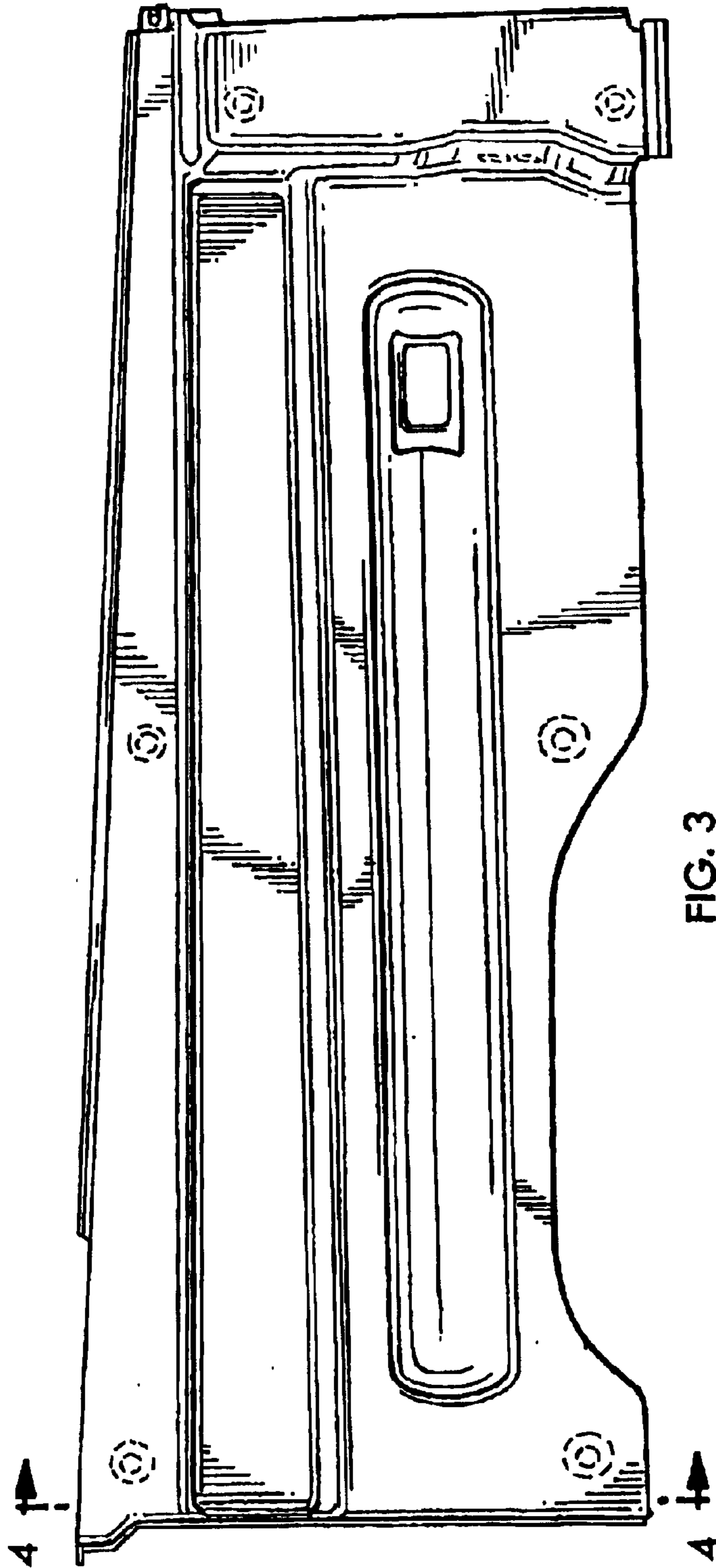

FIG. 3

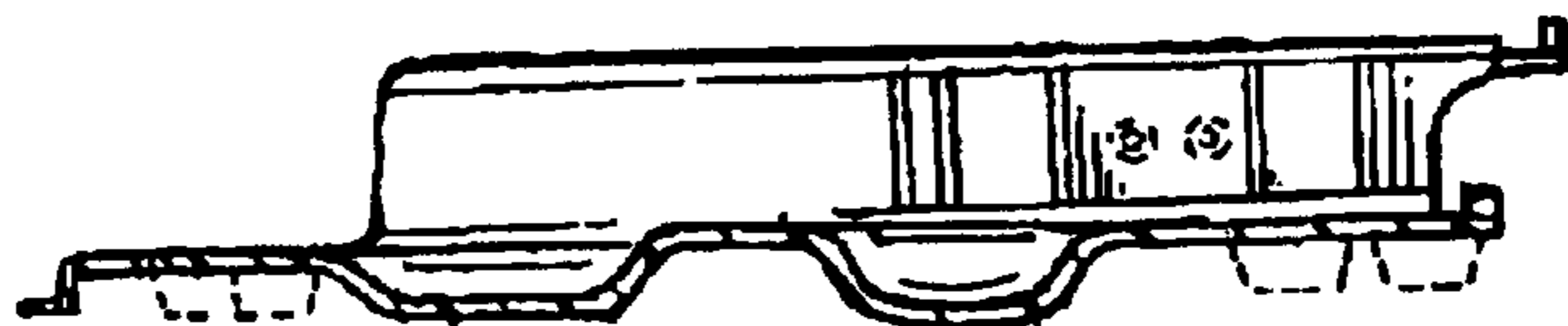

FIG. 4

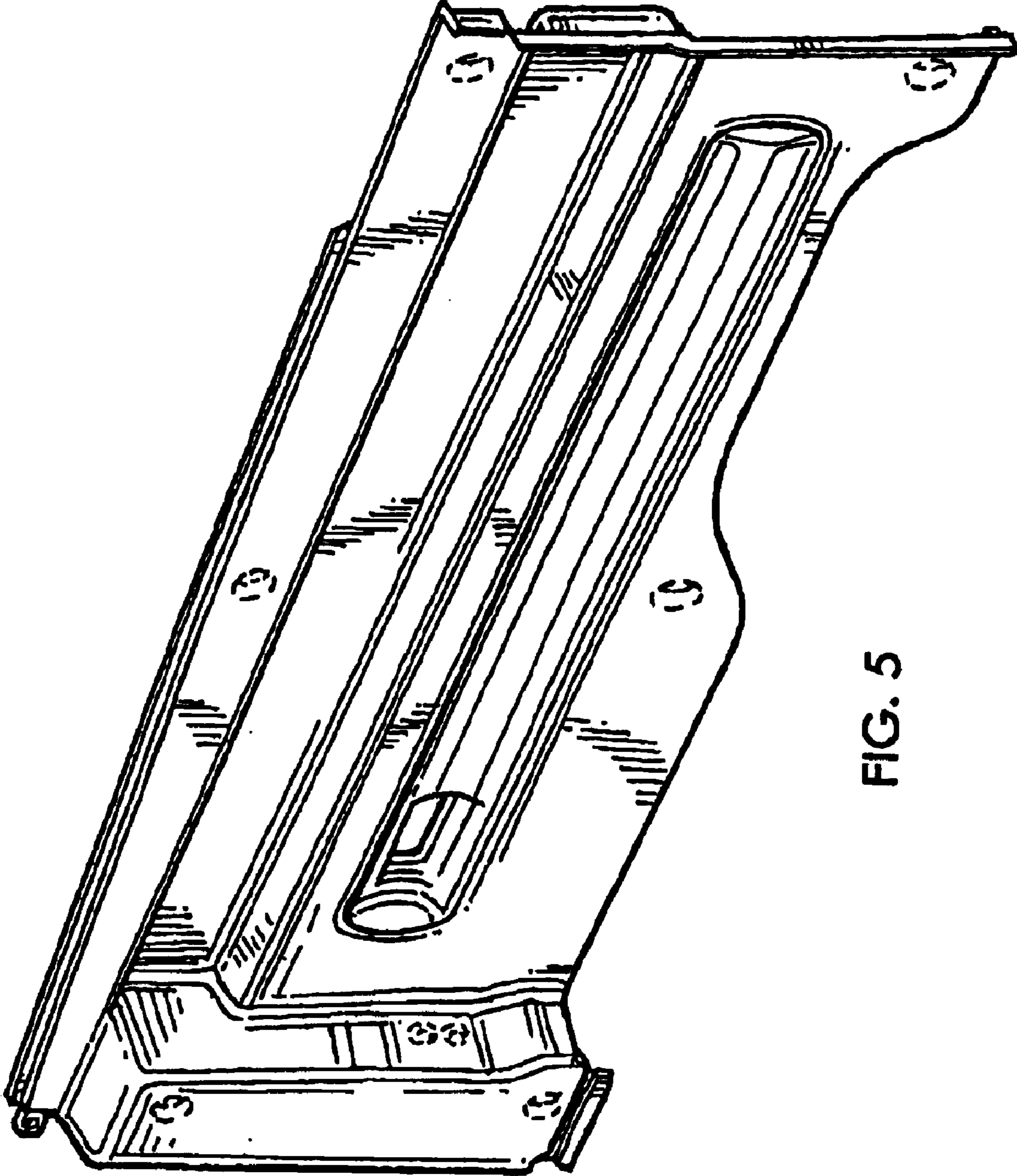

FIG. 5

