

US00D495644S1

(12) **United States Design Patent** (10) **Patent No.:** **US D495,644 S**
Perfetti et al. (45) **Date of Patent:** **** Sep. 7, 2004**

(54) **FENDER EXTENSION FOR AN OVER THE HIGHWAY TRUCK**

(75) Inventors: **Ruben Perfetti**, Greensboro, NC (US);
John Martin, Madison, NC (US);
James H. Lustig, Greensboro, NC (US)

(73) Assignee: **Volvo Trucks North America, Inc.**,
Greensboro, NC (US)

(**) Term: **14 Years**

(21) Appl. No.: **29/186,511**

(22) Filed: **Jul. 16, 2003**

(51) **LOC (7) Cl.** **12-16**

(52) **U.S. Cl.** **D12/196**

(58) **Field of Search** D12/196, 96, 97;
296/180.1, 180.2, 181, 190, 89.14, 89.16

(56) **References Cited**

U.S. PATENT DOCUMENTS

D424,496 S	*	5/2000	Damon et al.	D12/196
D431,806 S	*	10/2000	Damon et al.	D12/196
D435,237 S	*	12/2000	Damon et al.	D12/196
D436,335 S	*	1/2001	Beigel	D12/96
D440,195 S	*	4/2001	Damon et al.	D12/196

OTHER PUBLICATIONS

1 page section of a story board used by the inventors of the present application depicting competing trucks that were on the market when this design was completed 1990 . . . Kenworth trucks to the year 2000.

* cited by examiner

Primary Examiner—Melody N. Brown
(74) *Attorney, Agent, or Firm*—Watts Hoffmann Co.

(57) **CLAIM**

The ornamental design for a fender extension for an over the highway truck, as shown and described.

DESCRIPTION

FIG. 1 is a perspective view of the fender extension for an over the highway truck of our new design;
FIG. 2 is a perspective view of the fender extension;
FIG. 3 is a top plan view of the fender extension;
FIG. 4 is a front elevational view of the fender extension;
FIG. 5 is a right side elevational view of the fender extension;
FIG. 6 is a rear elevational view of the fender extension;
FIG. 7 is a left side elevational view of the fender extension;
and,
FIG. 8. is a bottom plan view of the fender extension.
The broken lines shown are for illustrative purposes only and form no part of the claimed design.

1 Claim, 4 Drawing Sheets

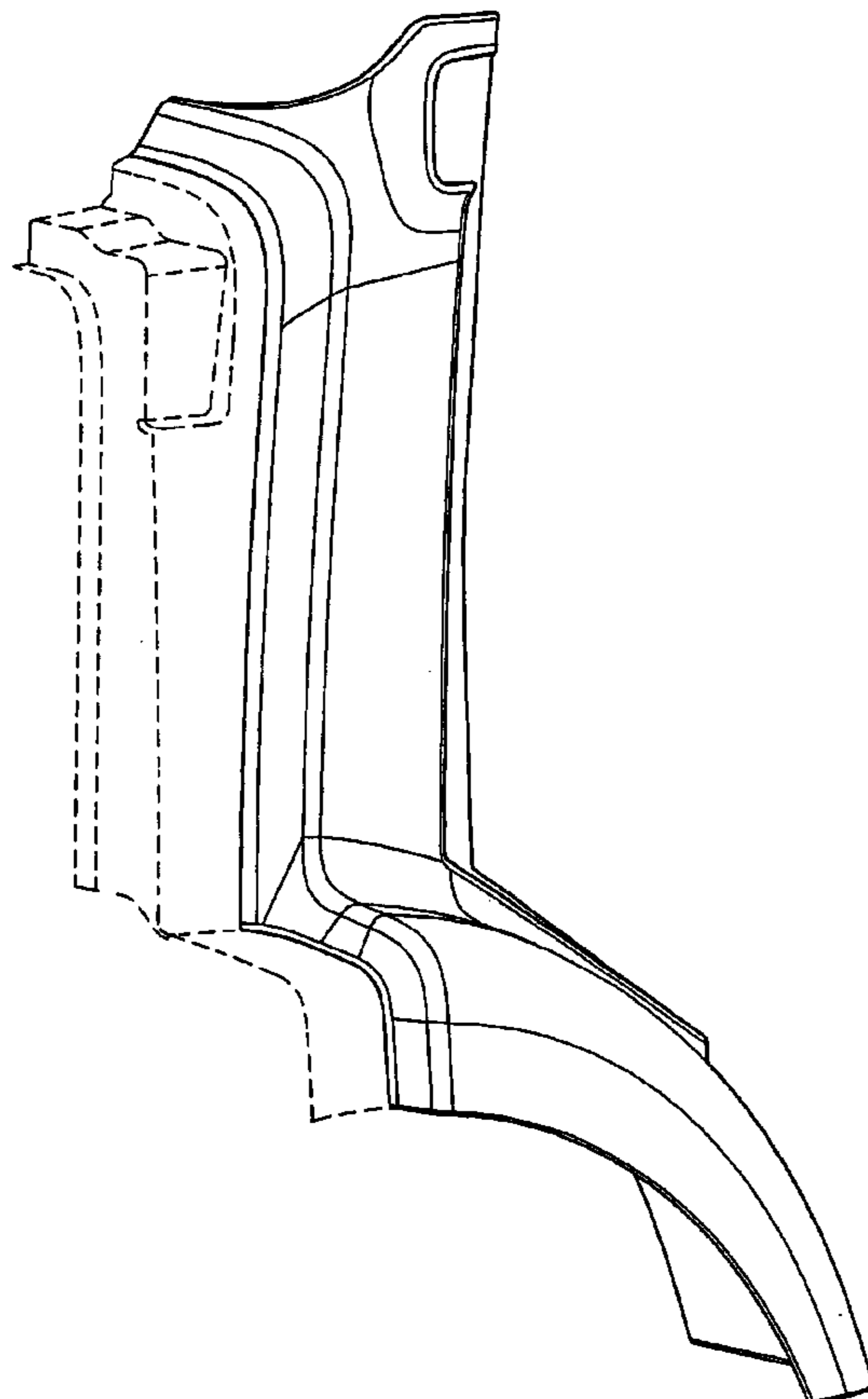

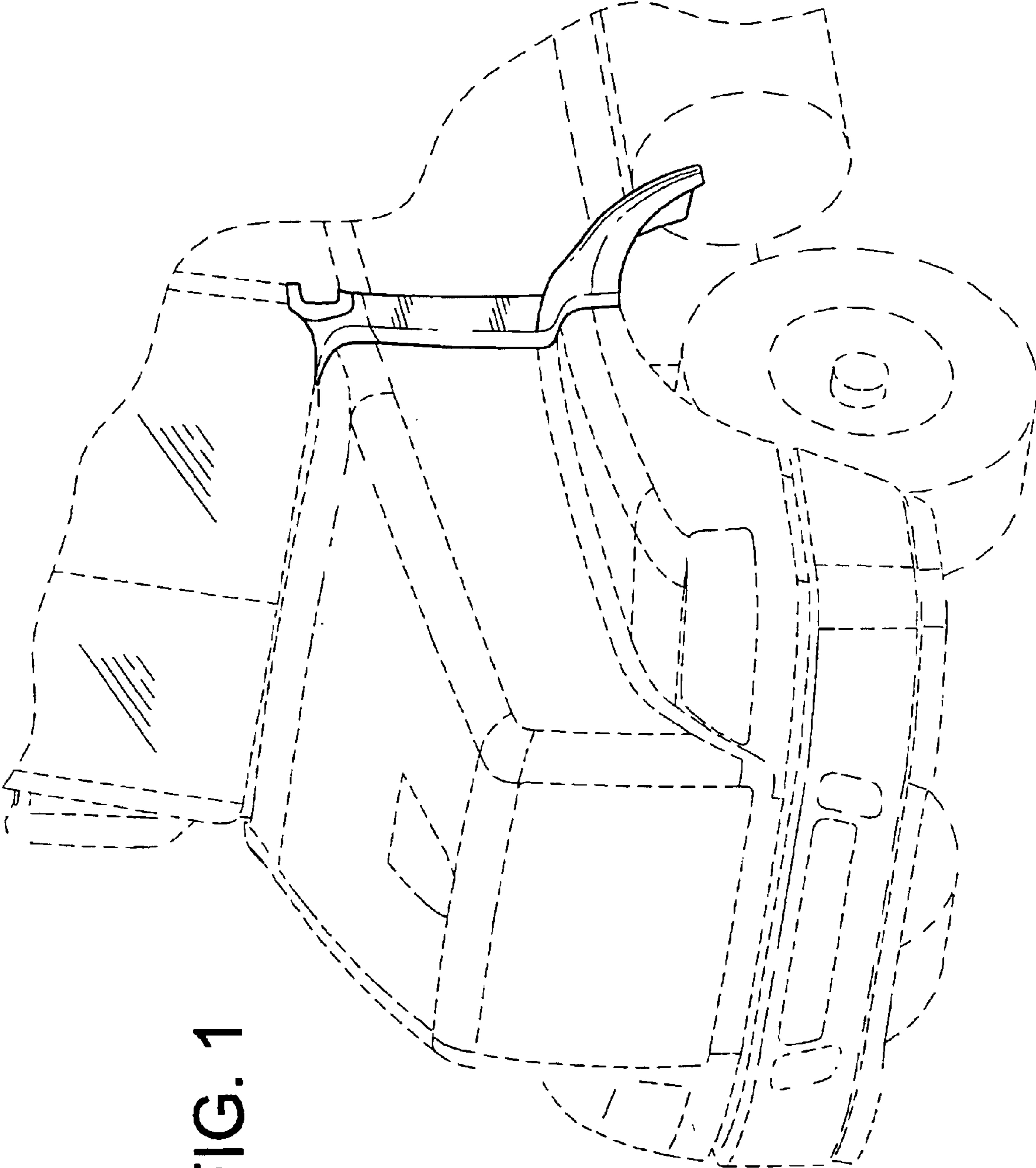

FIG. 1

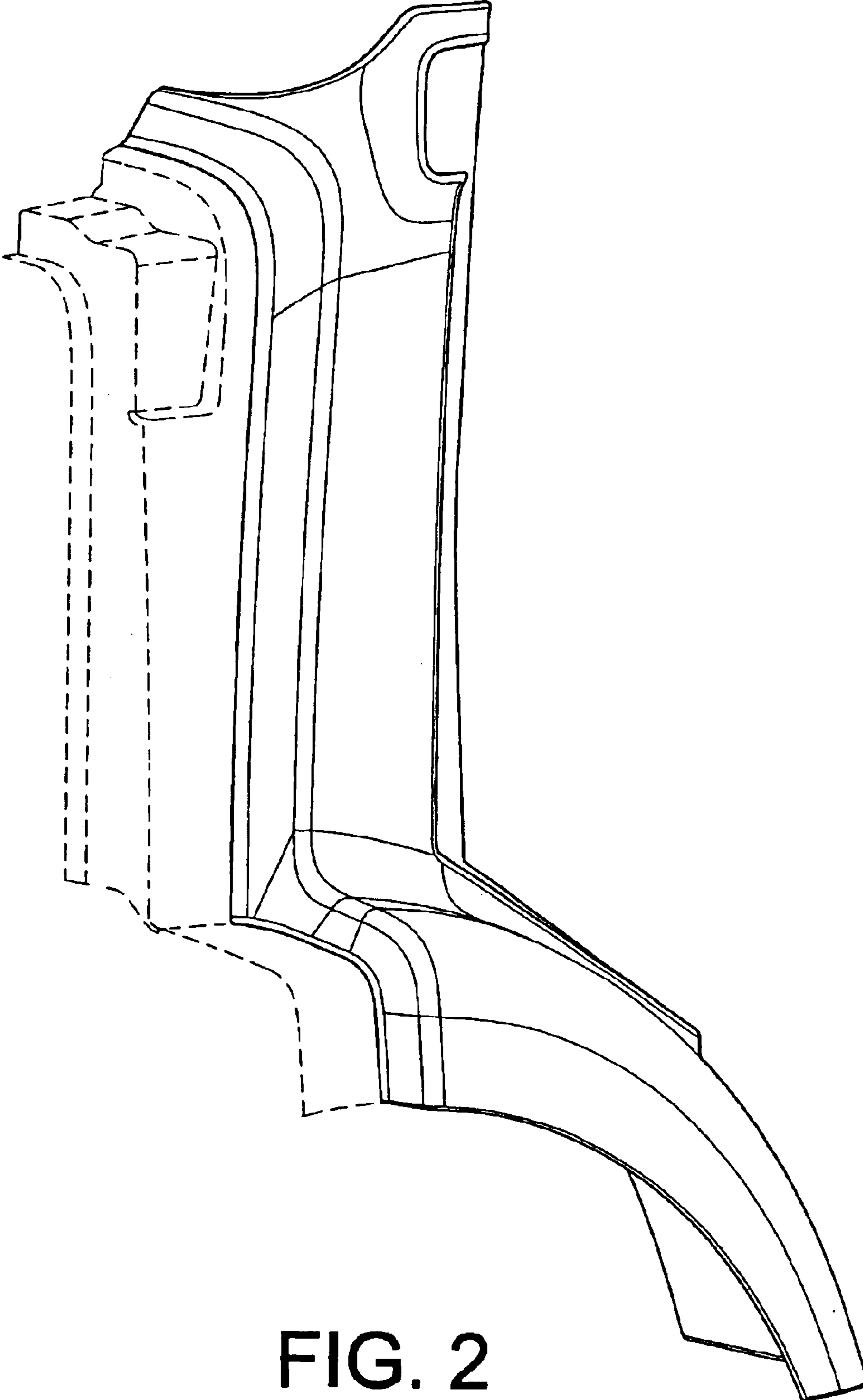

FIG. 2

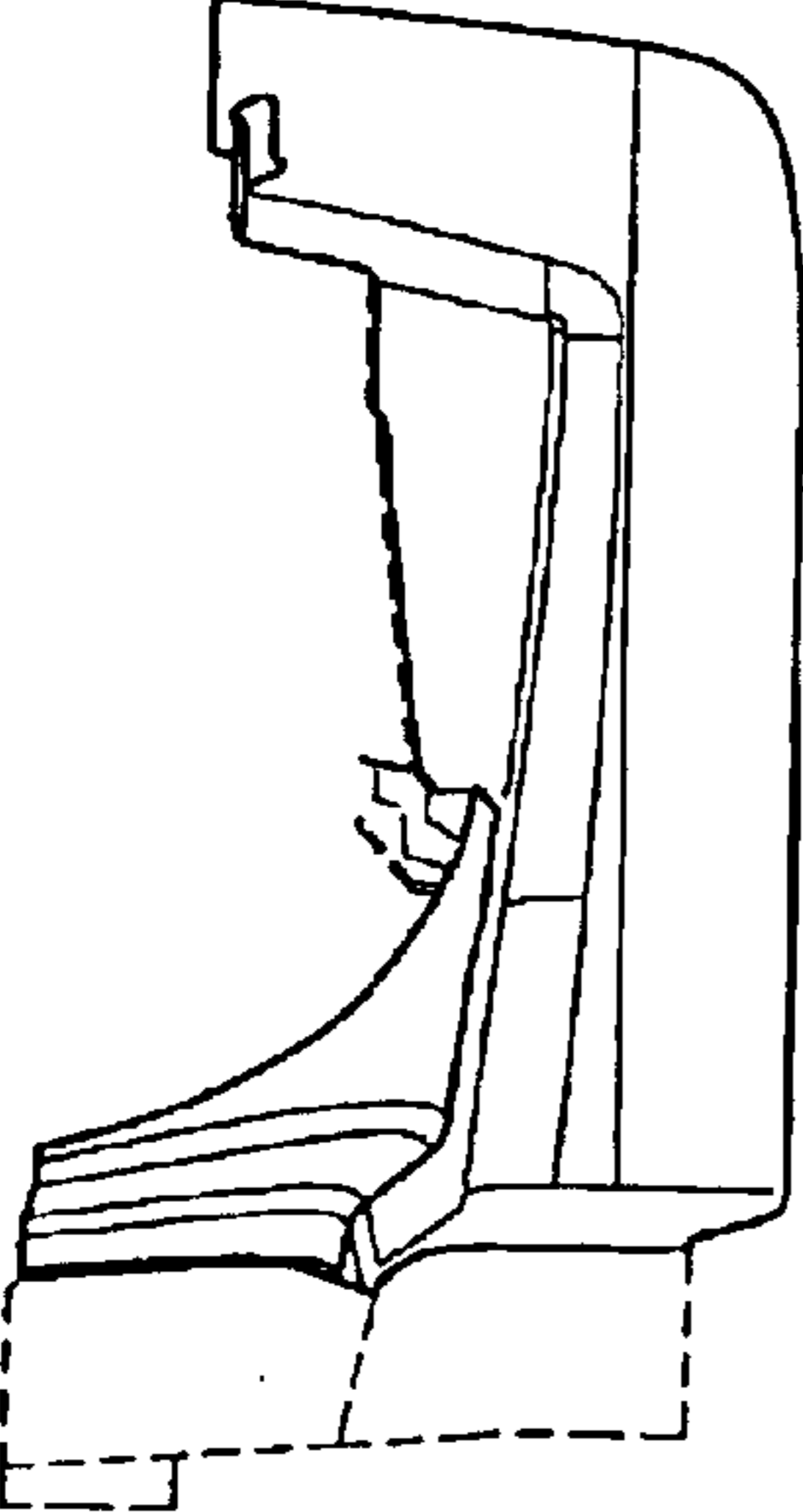

FIG. 3

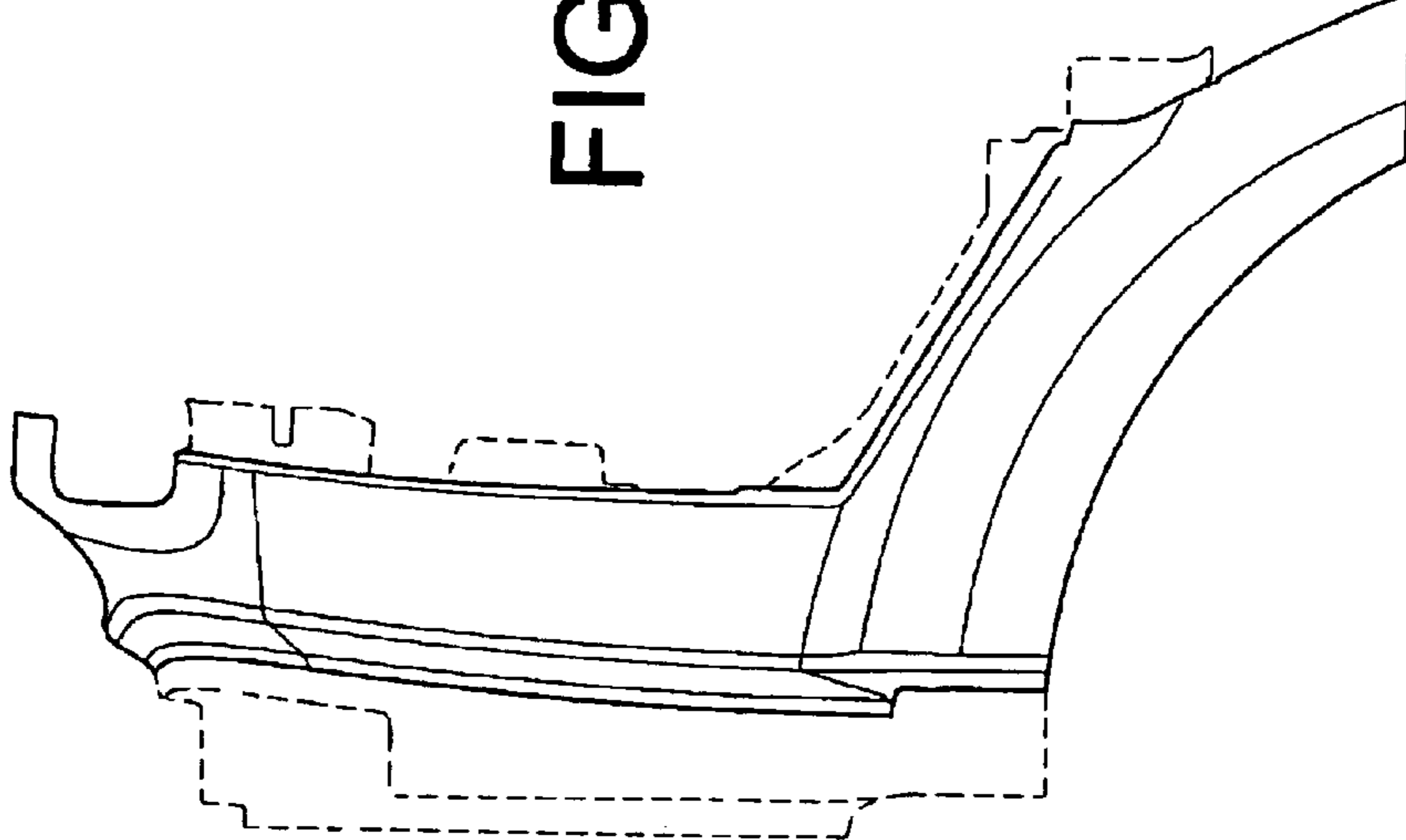

FIG. 5

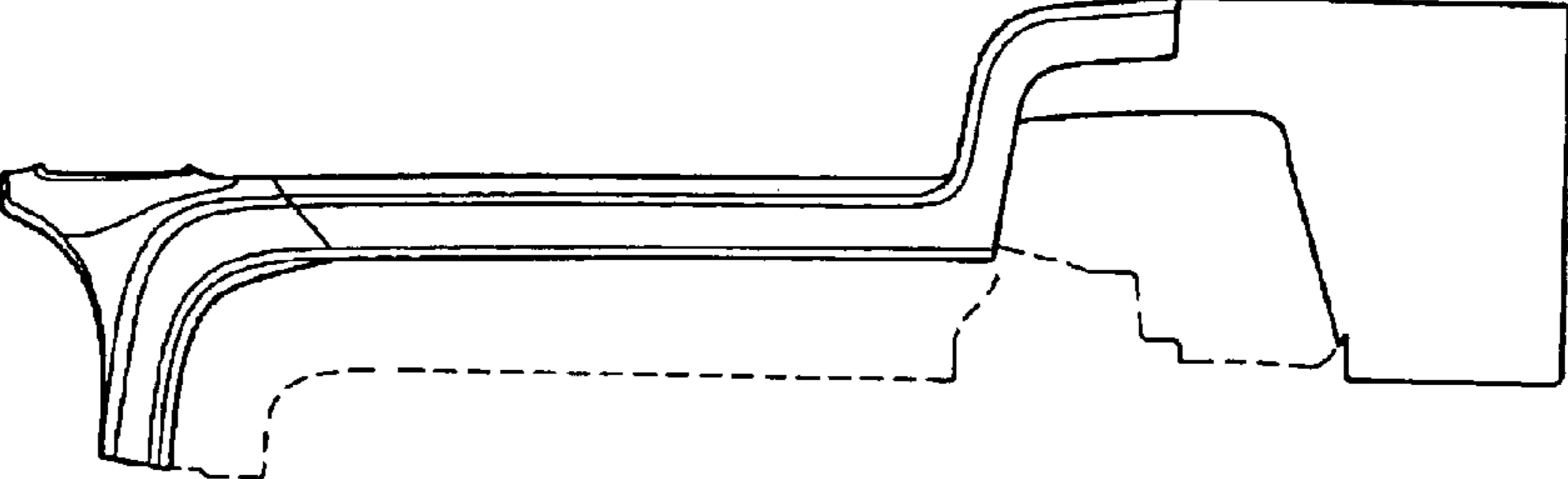

FIG. 4

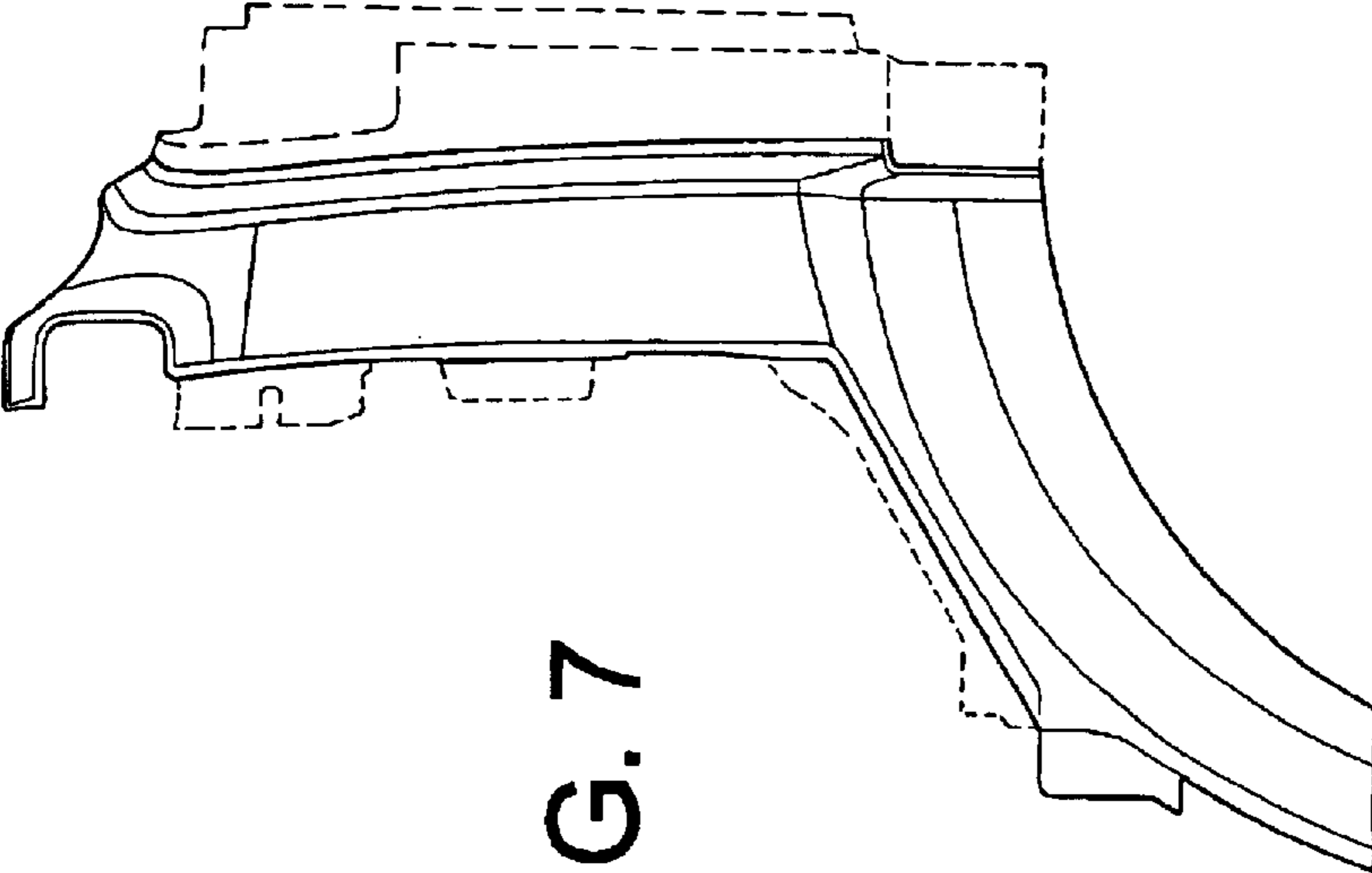

FIG. 7

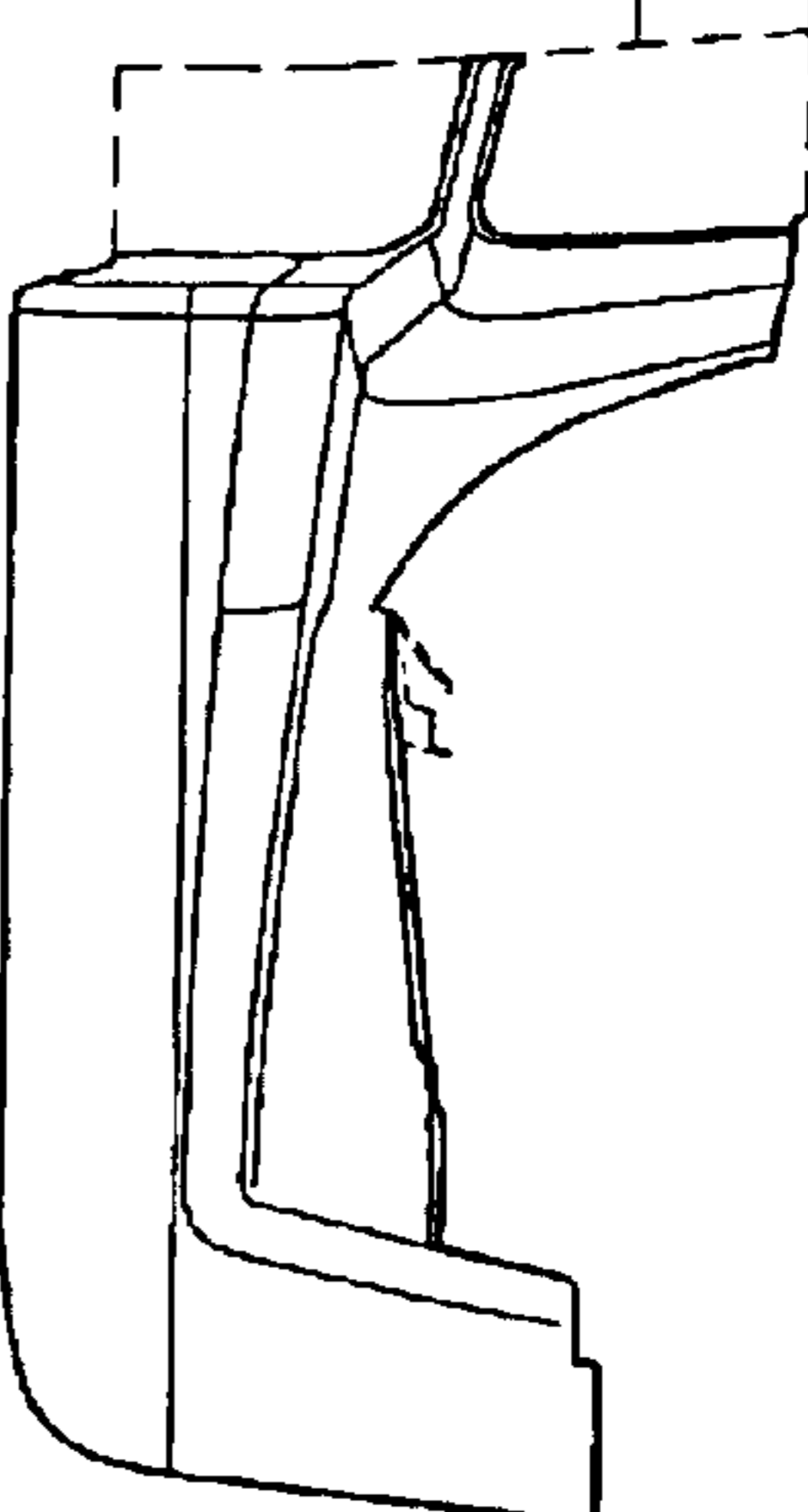

FIG. 8

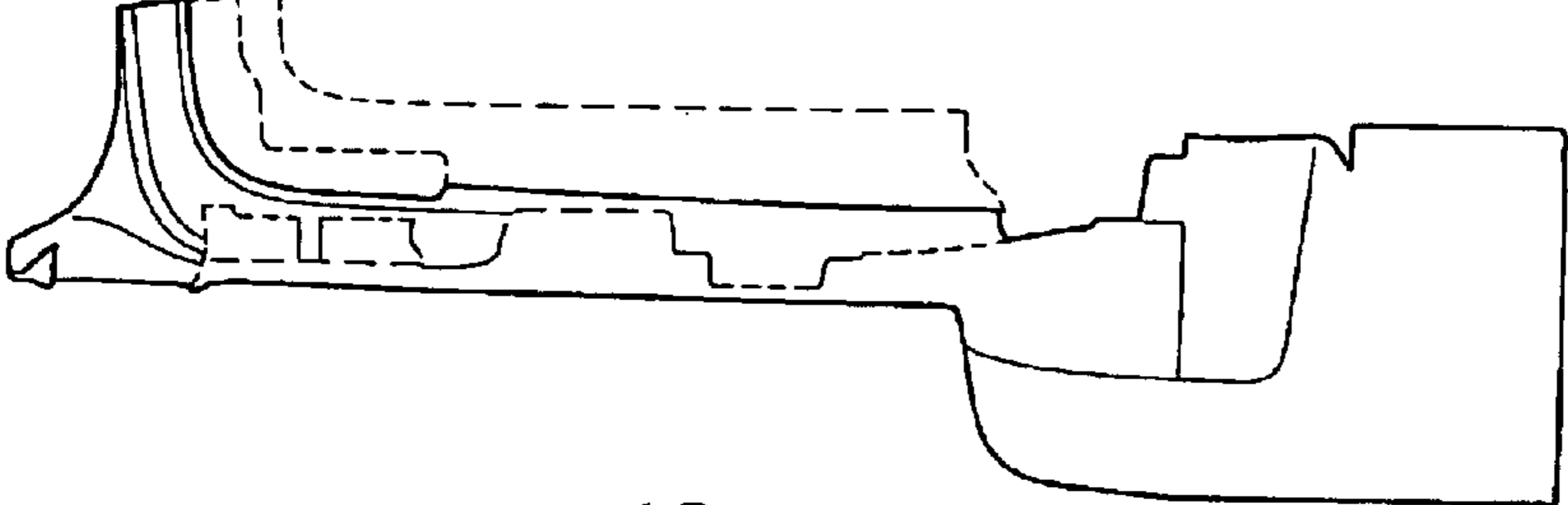

FIG. 6