

US00D495629S1

(12) **United States Design Patent**  
**Chelgren**

(10) **Patent No.:** **US D495,629 S**  
(45) **Date of Patent:** **\*\* Sep. 7, 2004**

(54) **SHOCK ABSORBING REAR SUSPENSION FOR WHEELCHAIR**

*Primary Examiner*—Marcus A. Jackson  
(74) *Attorney, Agent, or Firm*—Allan L. Harms

(75) **Inventor:** **Eric Mark Chelgren**, Vinton, IA (US)

(57) **CLAIM**

(73) **Assignee:** **Frog Legs, Inc.**, Vinton, IA (US)

I claim the ornamental design for shock absorbing rear suspension for wheelchair, as shown and described.

(\*\*) **Term:** **14 Years**

(21) **Appl. No.:** **29/191,560**

**DESCRIPTION**

(22) **Filed:** **Oct. 9, 2003**

(51) **LOC (7) Cl.** ..... **12-12**

FIG. 1 is a front left perspective of the design of a shock absorbing rear suspension for wheelchair;  
FIG. 2 is front elevation thereof;  
FIG. 3 is rear elevation thereof;  
FIG. 4 is a right elevational view thereof;  
FIG. 5 is a left elevational view thereof;  
FIG. 6 is a top plan view thereof; and,  
FIG. 7 is a bottom plan view thereof.

(52) **U.S. Cl.** ..... **D12/133**

(58) **Field of Search** ..... D12/128–133;  
280/284–288, 288.1, 288.3, 250.1, 304.1;  
297/DIG. 4, 423.19; 135/65–67

Broken line showing of parts of the wheelchair and wheel axle is for illustrative purposes only and forms no part of the claimed design.

(56) **References Cited**

**U.S. PATENT DOCUMENTS**

D429,186 S \* 8/2000 Trippensee et al. .... D12/133  
D475,324 S \* 6/2003 Hallgrimsson ..... D12/133

\* cited by examiner

**1 Claim, 7 Drawing Sheets**

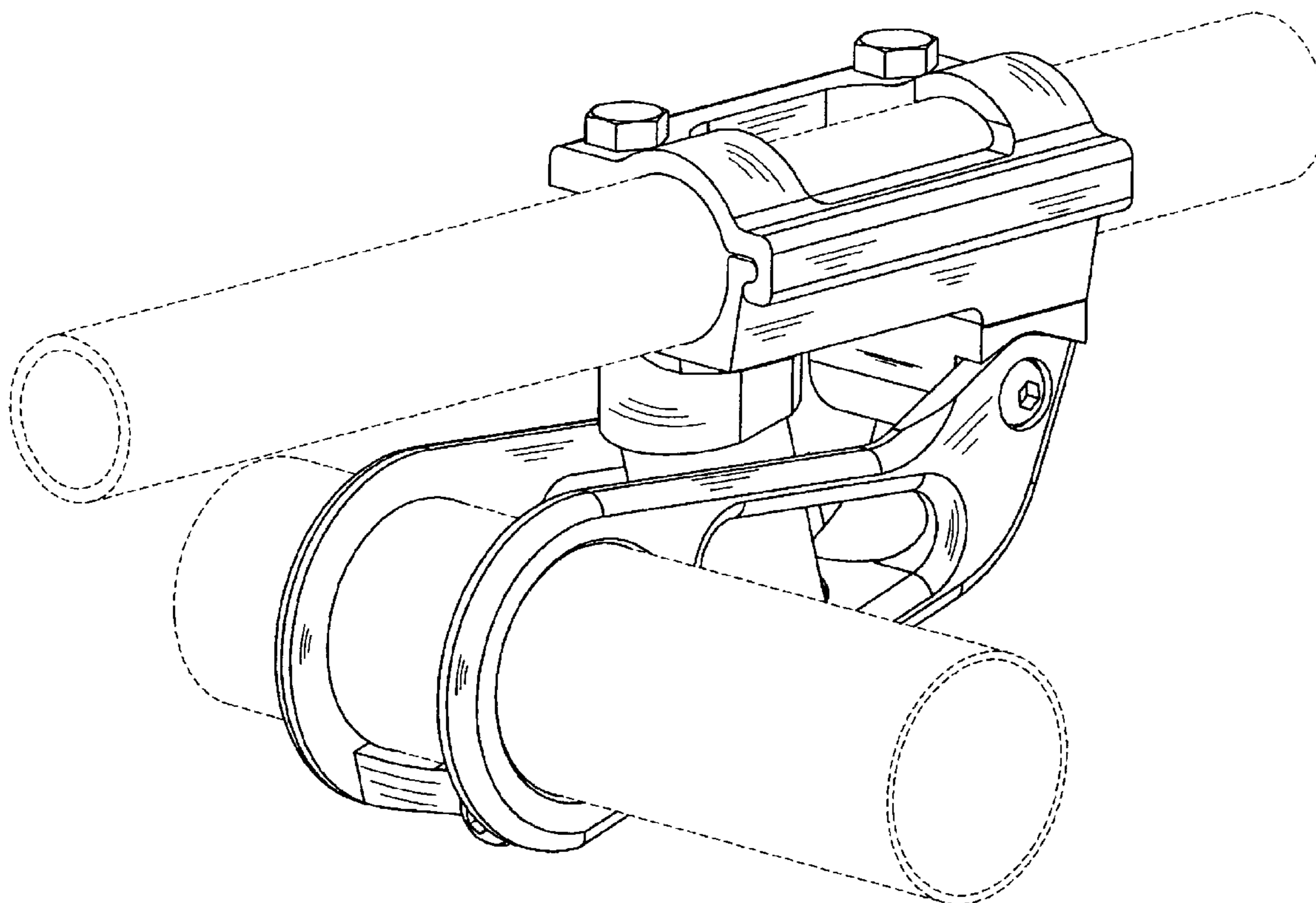

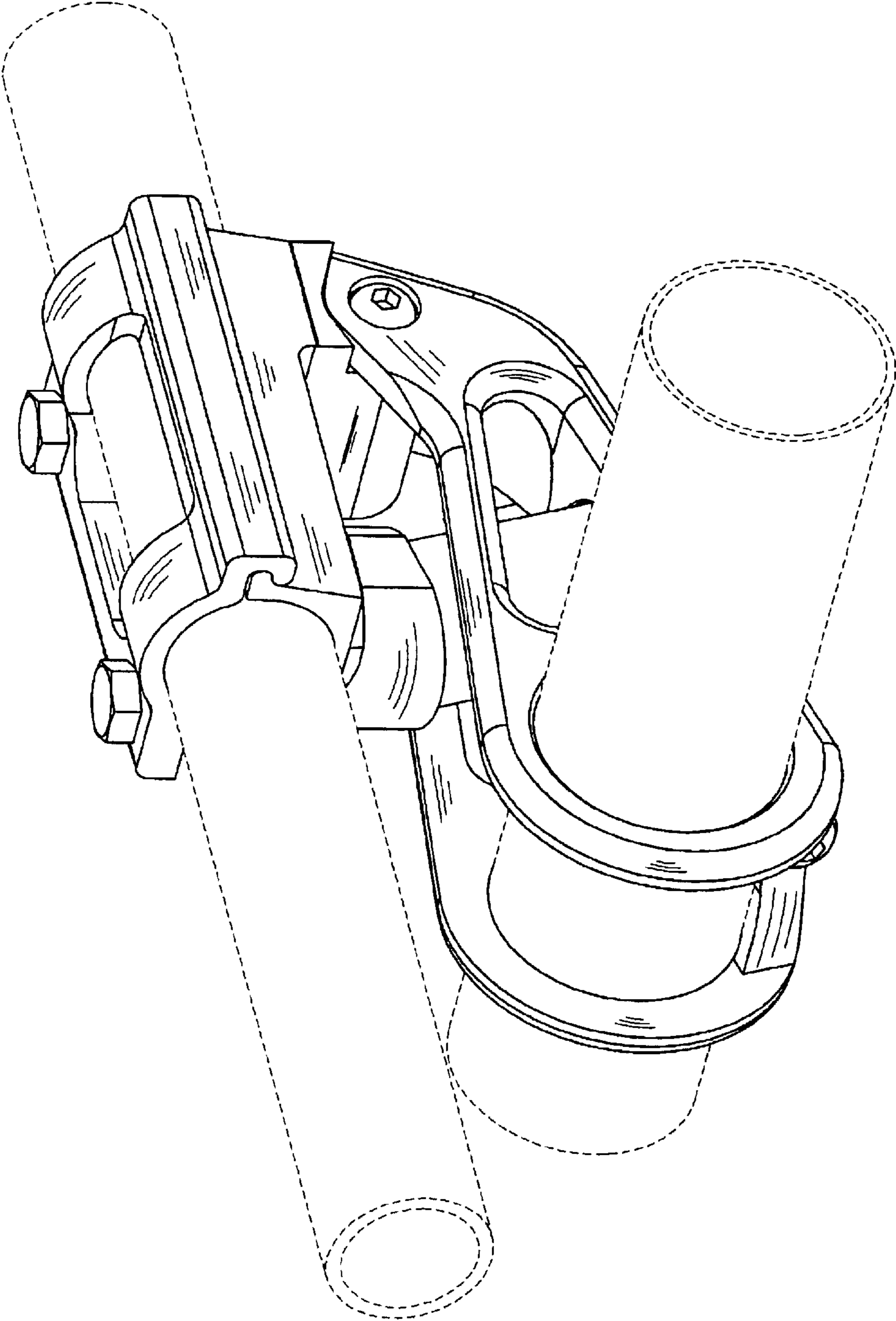

FIG. 1

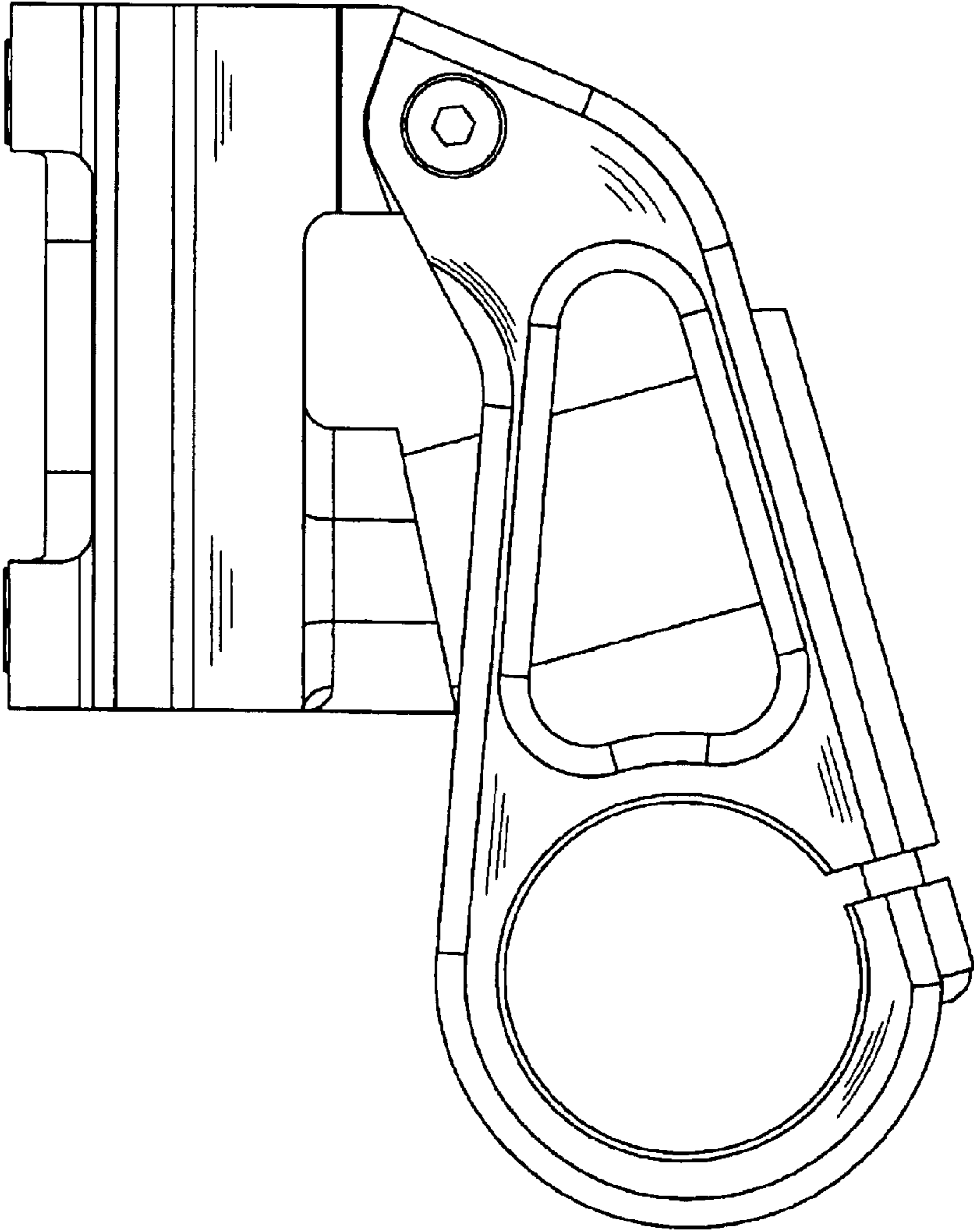

FIG. 2

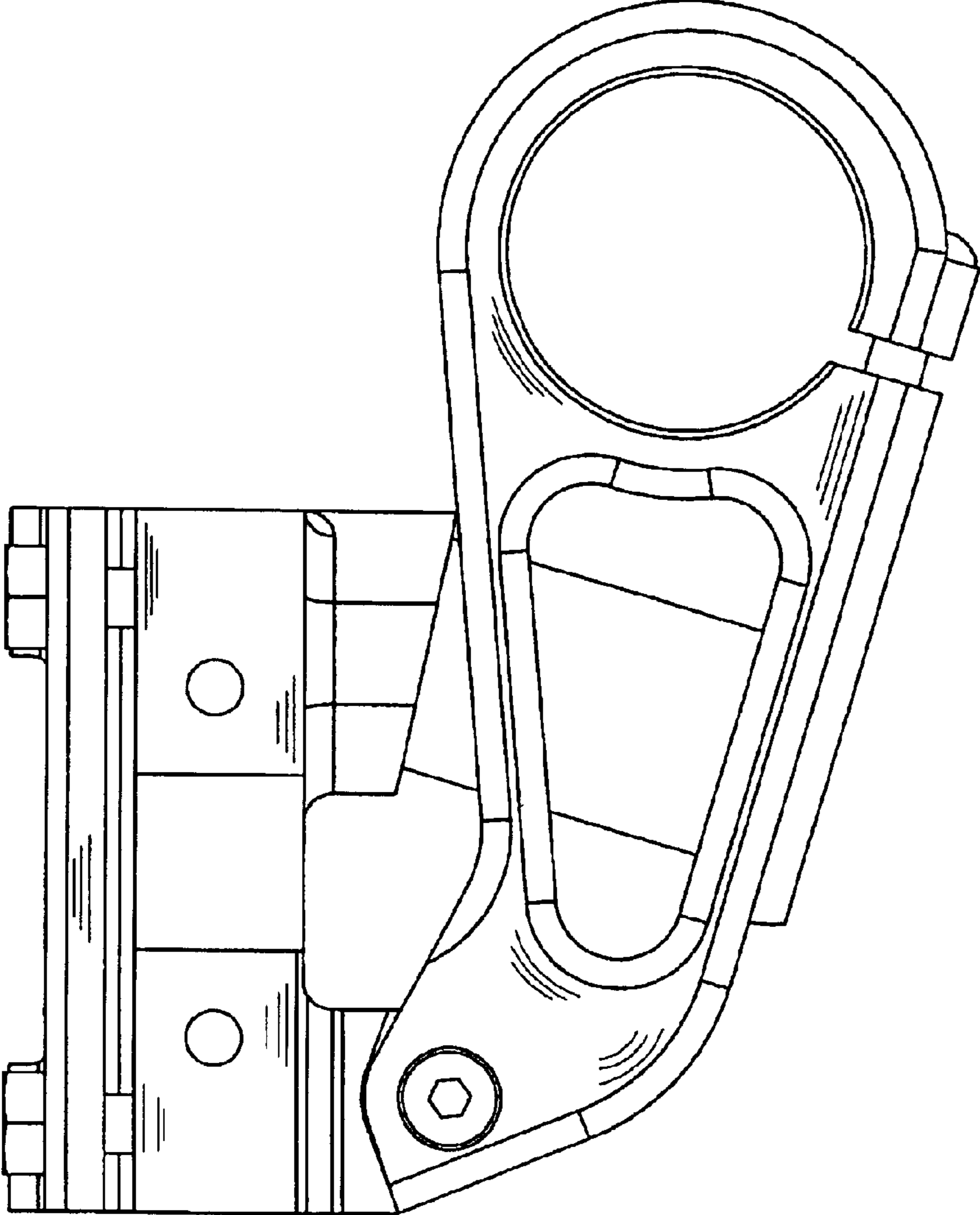

FIG. 3

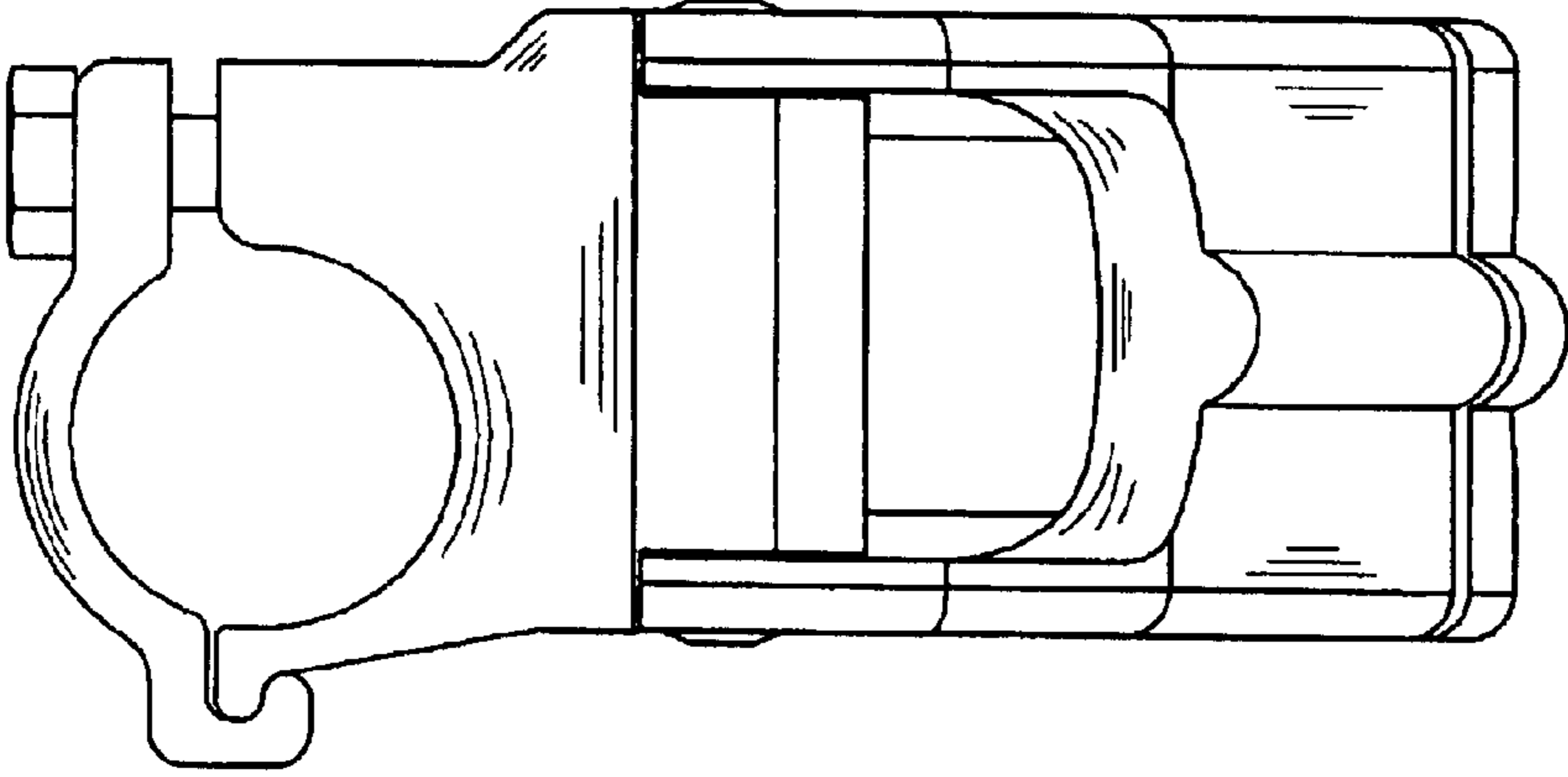

FIG. 4

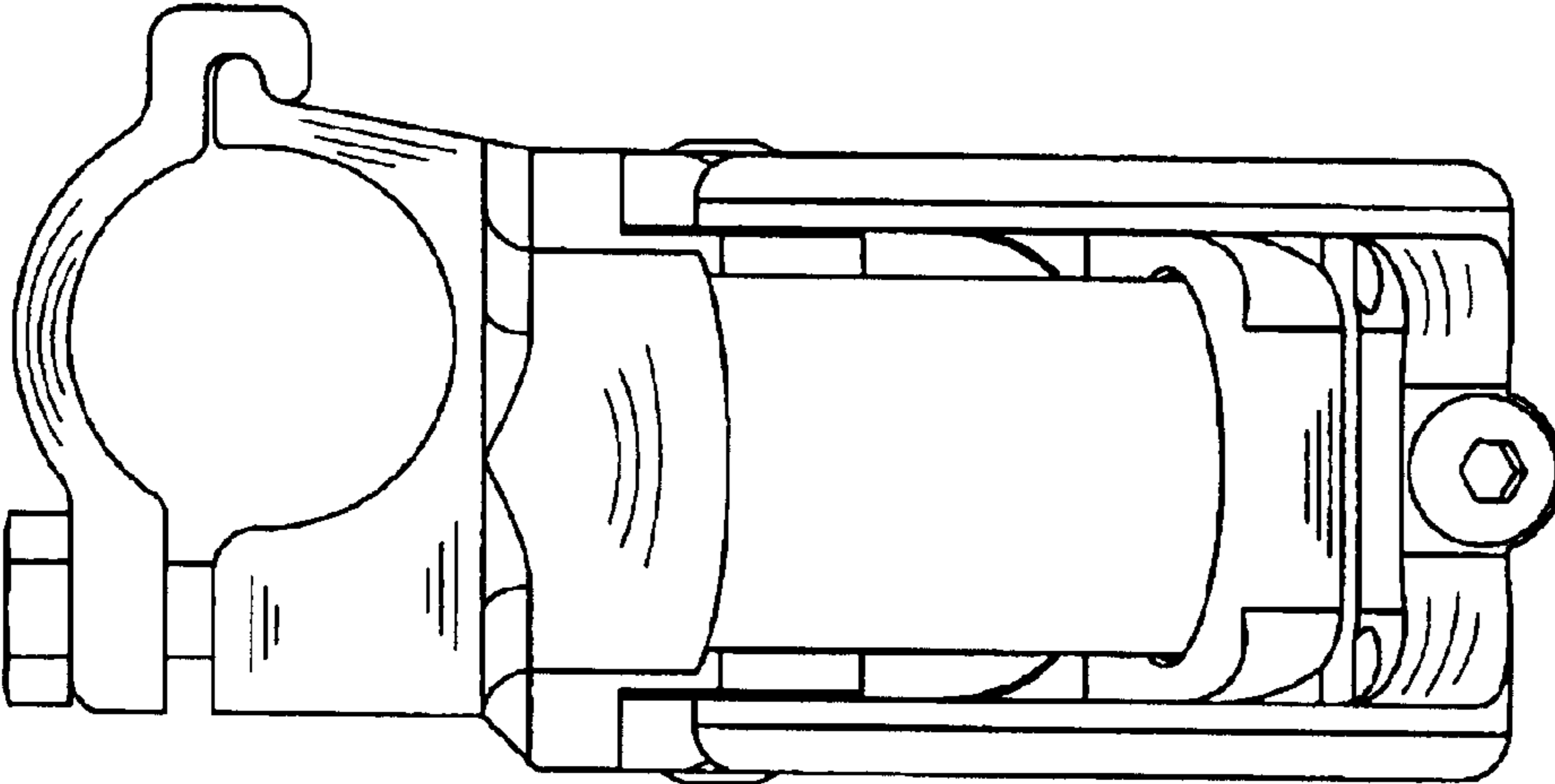

FIG. 5

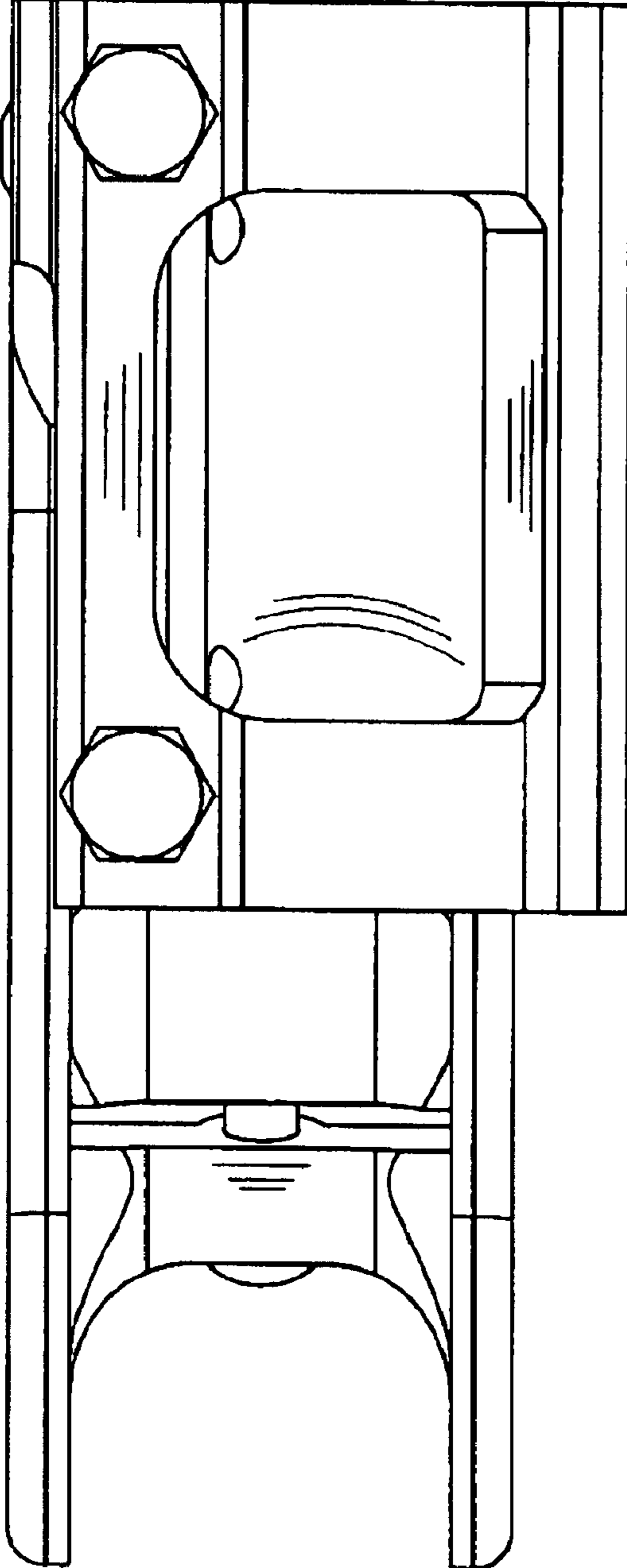

FIG. 6

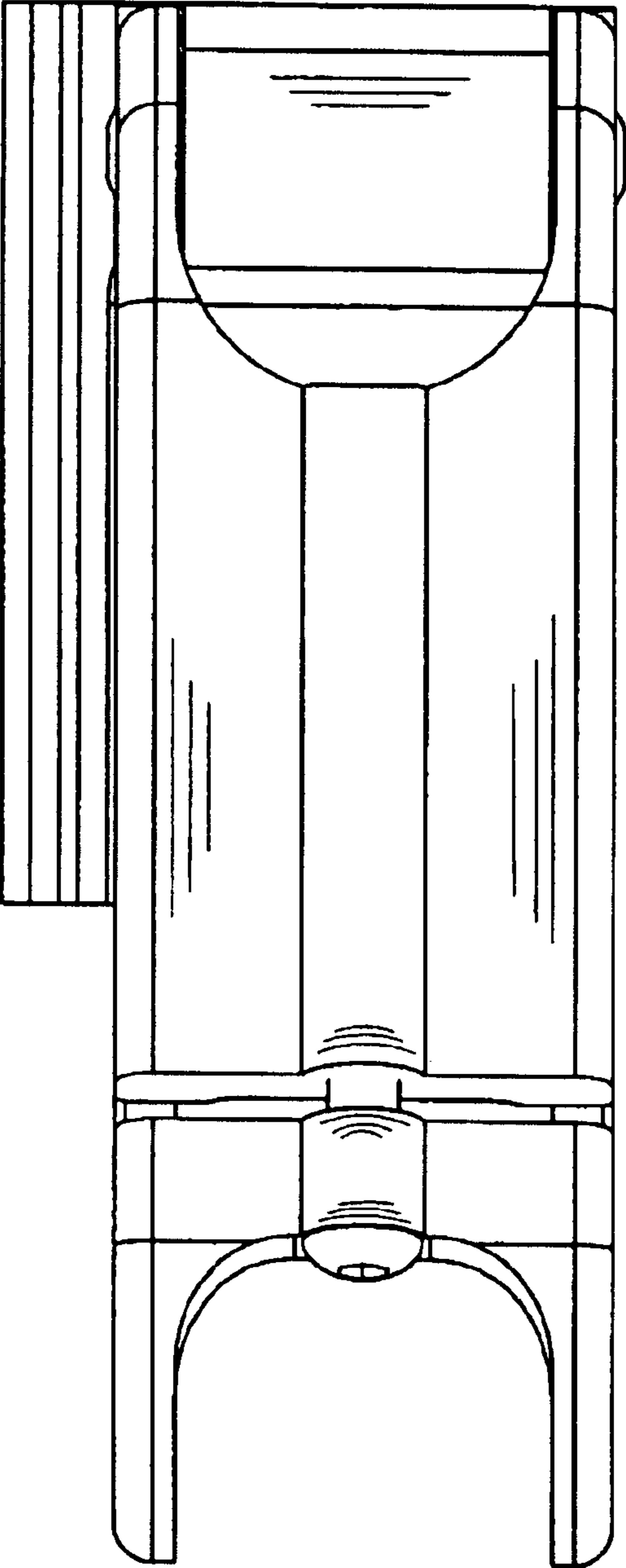

FIG. 7