



US00D495624S1

(12) **United States Design Patent**
Dolan et al.

(10) **Patent No.:** **US D495,624 S**
(45) **Date of Patent:** **** Sep. 7, 2004**

(54) **AUTOMOBILE BODY**
(75) Inventors: **Julie G Dolan**, Beverly Hills, MI (US);
Clifford Wilkins, Rochester Hills, MI (US); **Ricardo Z Aneiros**, Bingham Farms, MI (US); **Mark D Hall**, Rochester, MI (US); **Mark C Trostle**, Clarkston, MI (US); **Aaron Pizzuti**, Royal Oak, MI (US); **Dennis Myles**, W. Bloomfield, MI (US); **John D Bucci**, Rochester Hills, MI (US)

D466,053 S 11/2002 O'Connell et al.
D466,443 S 12/2002 Faurote et al.
D472,850 S 4/2003 Frasher et al.
D479,492 S * 9/2003 Gale et al. D12/91
D482,990 S * 12/2003 Sims et al. D12/91

* cited by examiner

Primary Examiner—Melody N. Brown
(74) *Attorney, Agent, or Firm*—Ralph E. Smith

(73) Assignee: **DaimlerChrysler Corporation**, Auburn Hills, MI (US)

(57) **CLAIM**

The ornamental design for an automobile body, as shown and described.

(**) Term: **14 Years**

DESCRIPTION

(21) Appl. No.: **29/189,195**

FIG. 1 is a front perspective view of an automobile body showing our new design;

(22) Filed: **Aug. 29, 2003**

FIG. 2 is a back perspective view thereof;

Related U.S. Application Data

FIG. 3 is a side view thereof;

(63) Continuation of application No. 29/172,968, filed on Dec. 19, 2002, now Pat. No. Des. 479,155.

FIG. 4 is a front view thereof; and,

(51) **LOC (7) Cl.** **12-08**

FIG. 5 is a rear view thereof.

(52) **U.S. Cl.** **D12/91**

(58) **Field of Search** D12/90-92, 86;
D21/424, 433; 296/185

It will be understood that the roof of the automobile body is plain and unornamental, and further that dashed lines presented in the drawings are for illustration only, and do not form a part of the claimed design.

(56) **References Cited**

U.S. PATENT DOCUMENTS

D454,521 S 3/2002 Allen

1 Claim, 5 Drawing Sheets

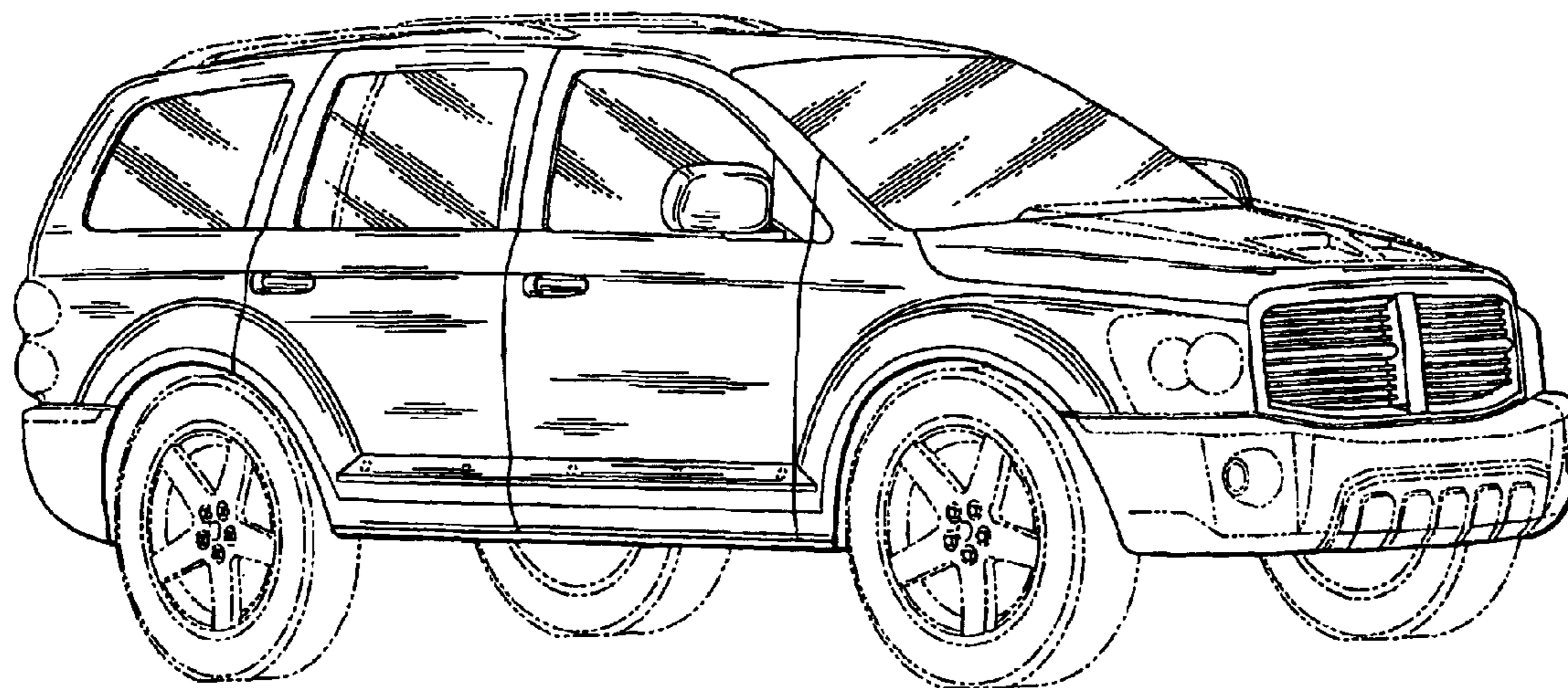

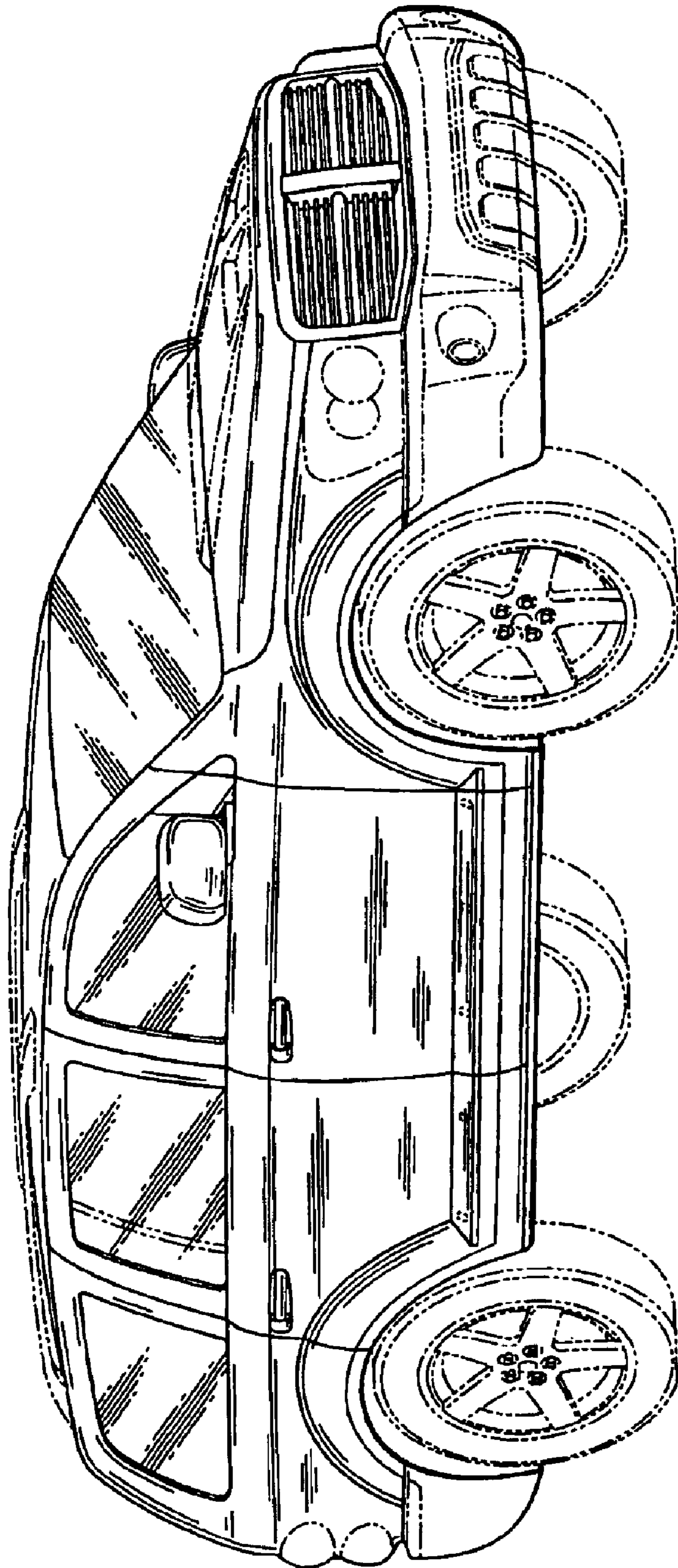

Fig. 1

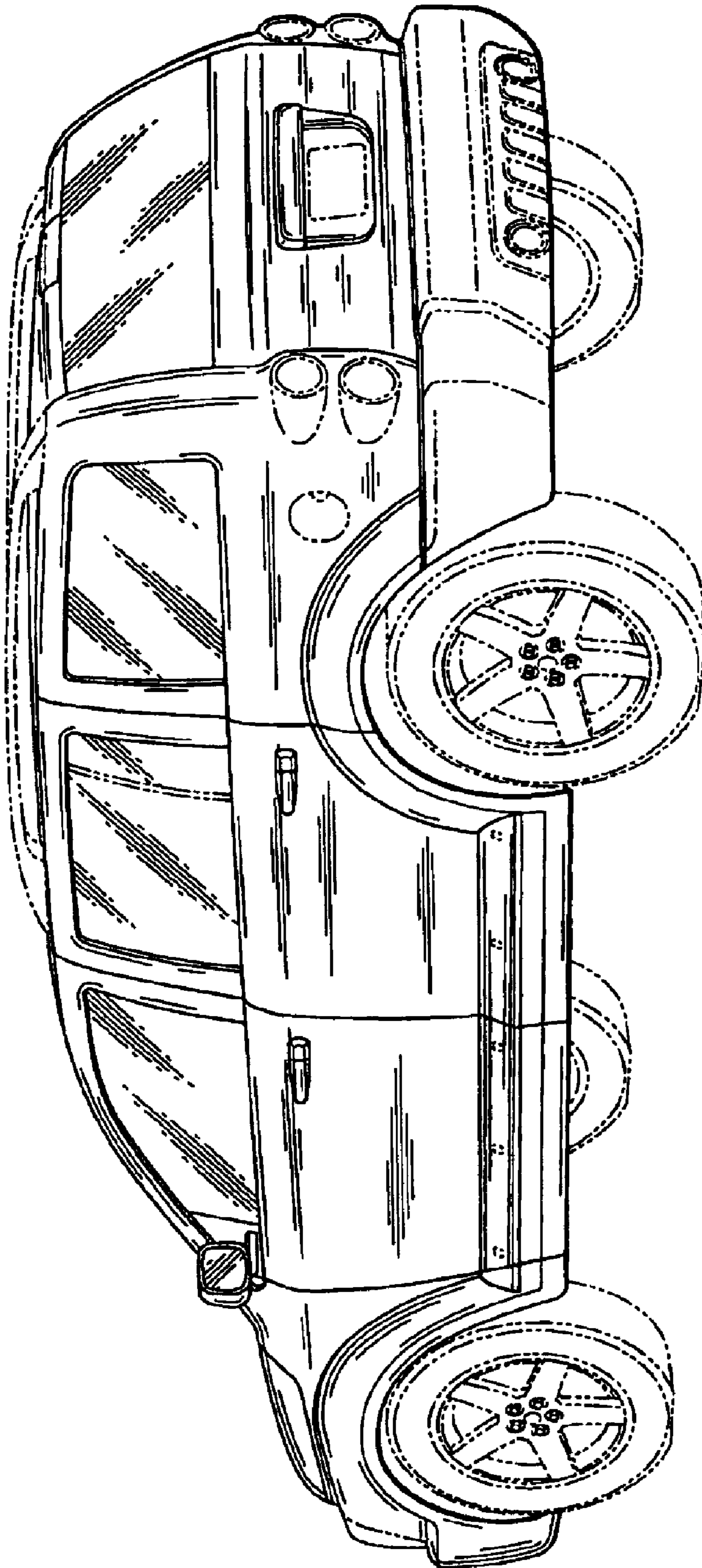

Fig. 2

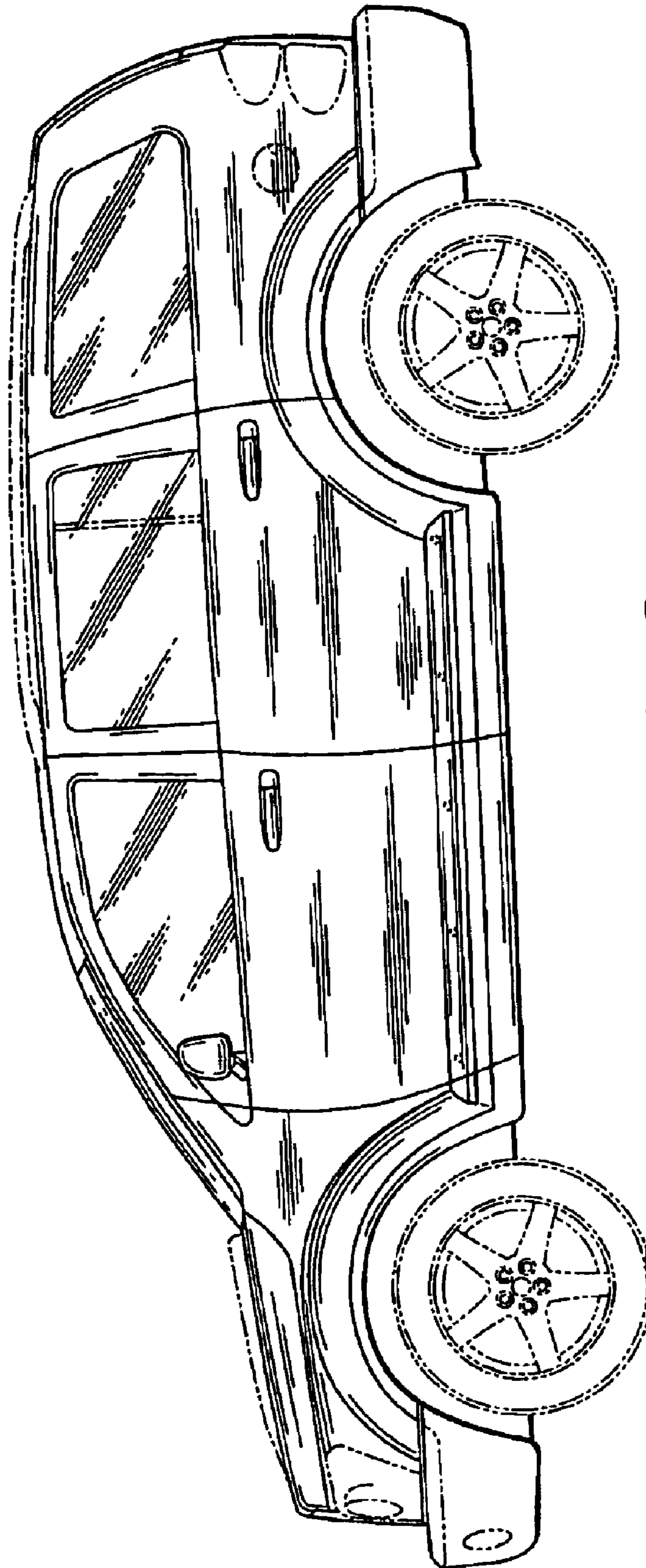

Fig. 3

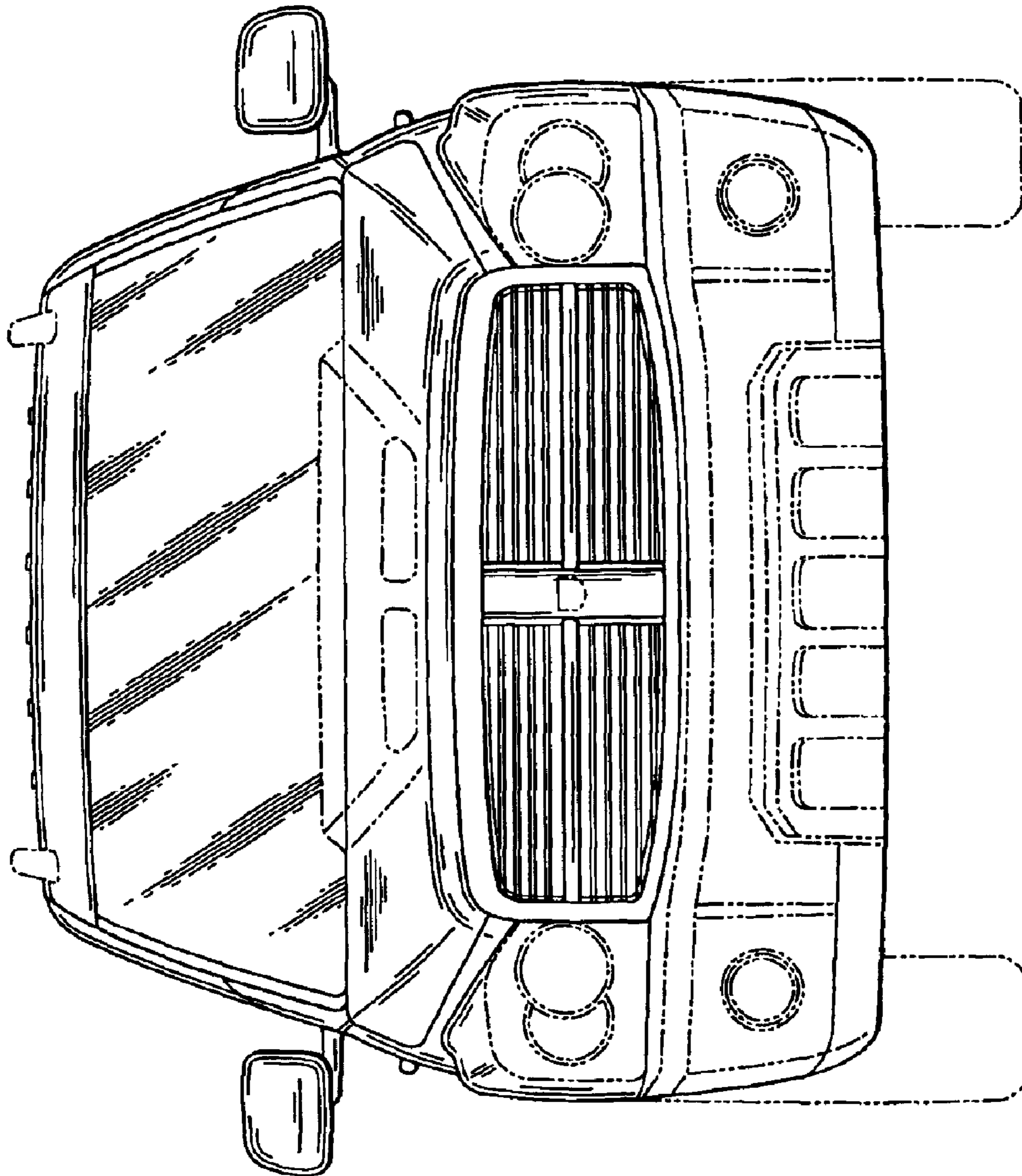

Fig. 4

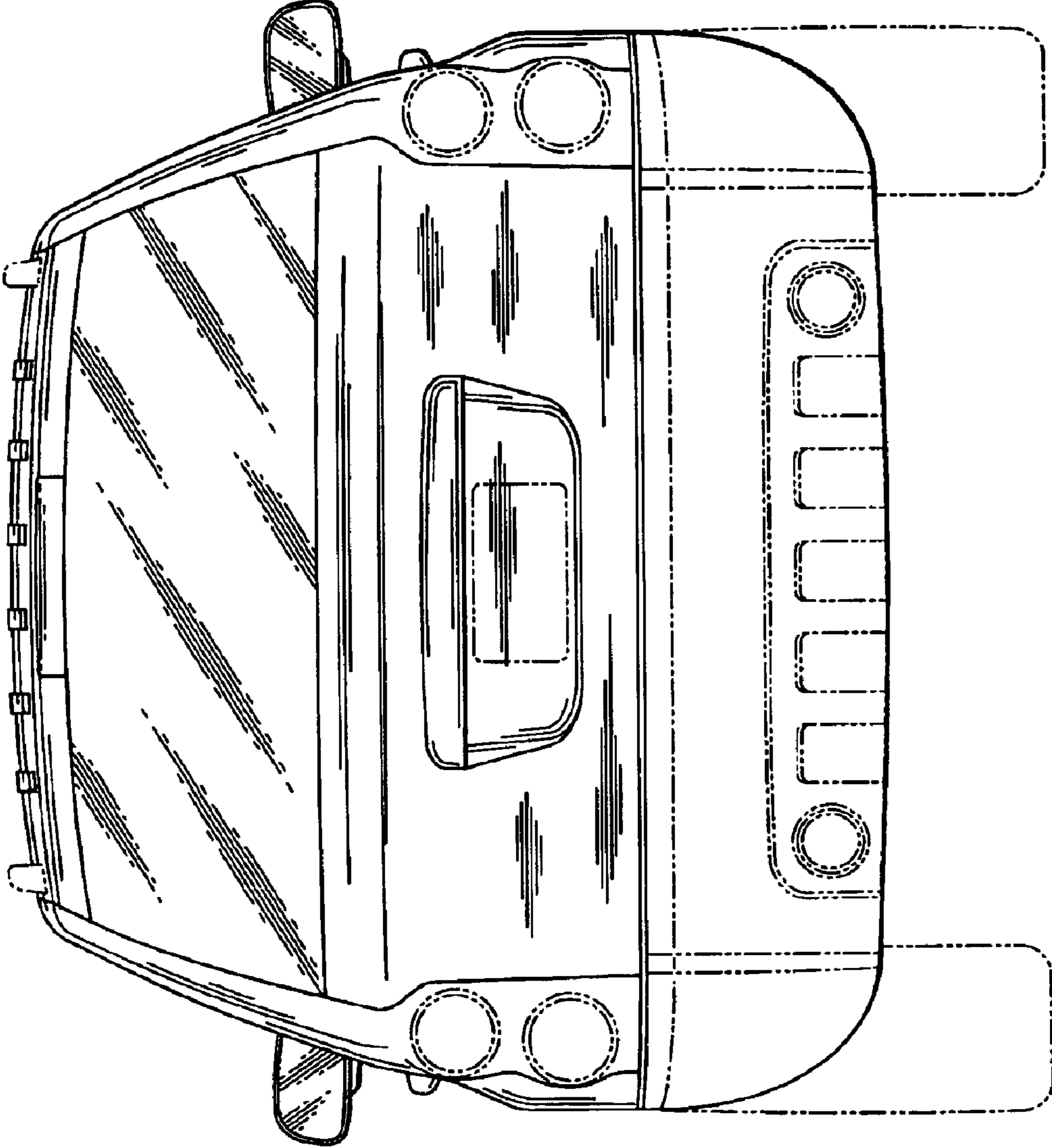

Fig. 5