

US00D495374S1

(12) **United States Design Patent** (10) **Patent No.:** **US D495,374 S**
Chuang (45) **Date of Patent:** **** Aug. 31, 2004**

(54) **CAMBERING VEHICLE HAVING A TRELLIS DESIGN**

(75) Inventor: **Jin Chen Chuang**, Taichung (TW)

(73) Assignee: **Unique Forces Company Limited** (VG)

(**) Term: **14 Years**

(21) Appl. No.: **29/188,760**

(22) Filed: **Aug. 22, 2003**

4,088,338 A	5/1978	Winchell et al.
4,123,079 A	10/1978	Biskup
4,133,551 A	1/1979	Biskup
4,165,093 A	8/1979	Biskup
4,325,565 A	4/1982	Winchell
4,526,390 A	7/1985	Skolnik
4,540,192 A	9/1985	Shelton
RE32,031 E	11/1985	Winchell
D291,211 S	* 8/1987	Man D21/423
4,776,604 A	10/1988	Valdez et al.
4,844,494 A	* 7/1989	Blanchard 280/87.05
5,039,121 A	8/1991	Holter
5,547,204 A	8/1996	Gamzo
5,785,331 A	7/1998	Rappaport
6,220,612 B1	4/2001	Beleski, Jr.

Related U.S. Application Data

(60) Division of application No. 29/186,392, filed on Jul. 15, 2003, which is a continuation-in-part of application No. 10/608,398, filed on Jun. 23, 2003.

(51) **LOC (7) Cl.** **21-01**

(52) **U.S. Cl.** **D21/423**

(58) **Field of Search** D21/419-435, D21/533, 760, 765, 771; D12/107, 110-112; 280/87.01, 87.021, 87.041, 87.042, 278, 220, 87.05; 180/181, 216, 219, 220

(56) **References Cited**

U.S. PATENT DOCUMENTS

1,303,127 A	5/1919	Wickman
1,336,100 A	4/1920	Shearer
1,664,858 A	4/1928	Headley
D219,372 S	* 12/1970	Levy D21/435
4,045,048 A	8/1977	Irwin
4,047,732 A	9/1977	Williams et al.
4,050,711 A	9/1977	Denzer
4,050,712 A	9/1977	Denzer et al.
4,050,713 A	9/1977	Williams
4,054,300 A	10/1977	Winchell
4,065,146 A	12/1977	Denzer
4,071,261 A	1/1978	Winchell
4,076,270 A	2/1978	Winchell
4,087,104 A	5/1978	Winchell et al.
4,087,106 A	5/1978	Winchell
4,087,107 A	5/1978	Winchell
4,087,108 A	5/1978	Winchell

(List continued on next page.)

FOREIGN PATENT DOCUMENTS

CA	2390224 A1	5/2001
WO	WO 01/32470 A3	5/2001
WO	WO 01/32470 A2	5/2001

OTHER PUBLICATIONS

Don Sherman, *Camber Jamboree*, Car and Driver Magazine, Jan. 1981, pp. 53-61, USA.

Primary Examiner—Raphael Barkai

(74) *Attorney, Agent, or Firm*—Lerner, David, Littenberg, Krumholz & Mentlik, LLP

(57) **CLAIM**

The ornamental design for a cambering vehicle having a trellis design, as shown and described.

DESCRIPTION

FIG. 1 is a perspective view of a cambering vehicle showing my new trellis design; FIG. 2 is a left side elevational view; FIG. 3 is a frontal elevational view; and, FIG. 4 is top plan view.

The broken lines shown in FIGS. 1-4 are for illustrative purposes only and form no part of the claimed design.

1 Claim, 3 Drawing Sheets

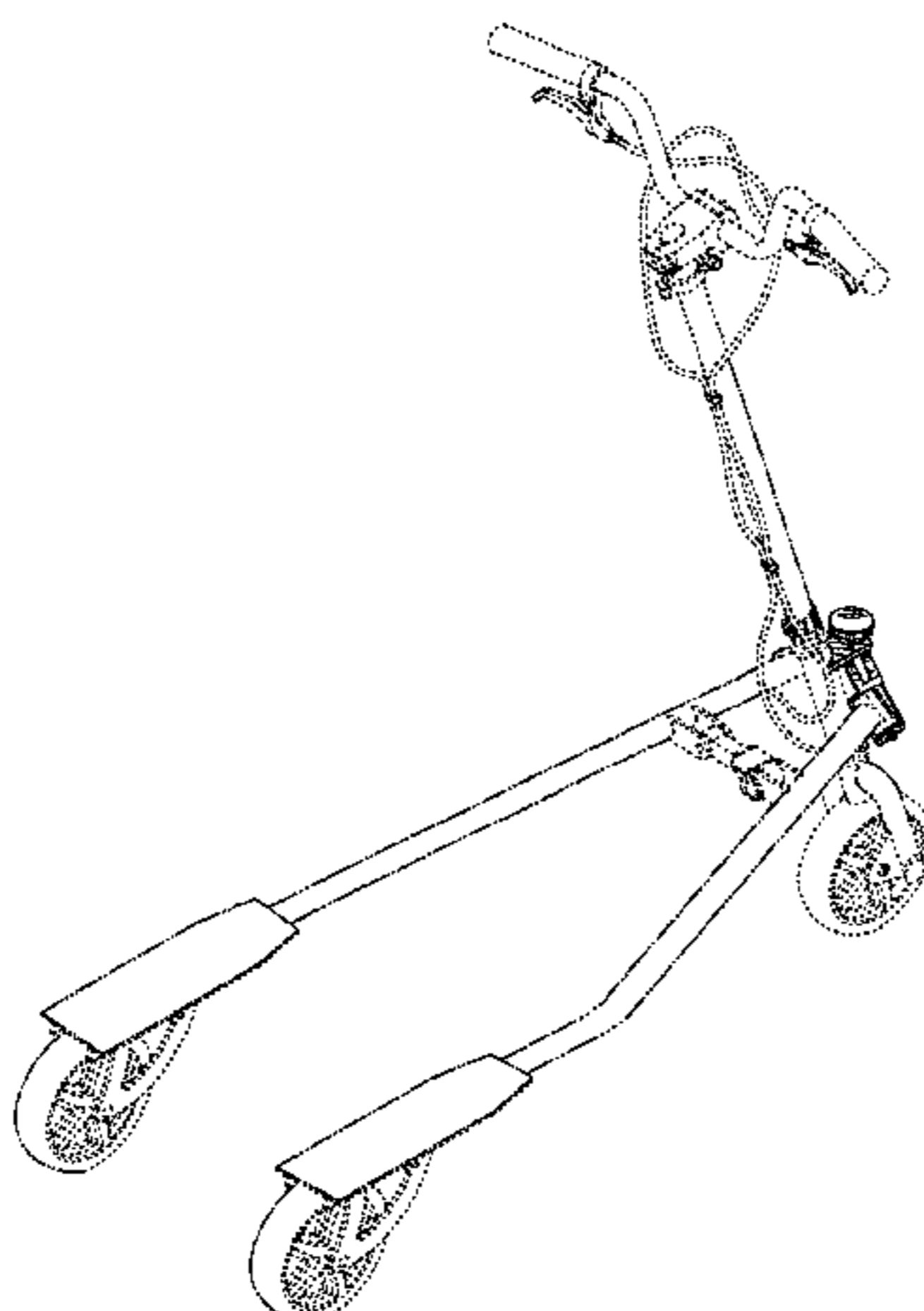

US D495,374 S

Page 2

U.S. PATENT DOCUMENTS

D444,184 S	*	6/2001	Kettler	D21/423	2002/0063406	A1	5/2002	Feng
6,318,741 B1		11/2001	Chen			2002/0063411	A1	5/2002	Feng
6,467,781 B1		10/2002	Feng			2002/0064417	A1	5/2002	Feng
6,499,751 B1		12/2002	Beleski, Jr.			2002/0070519	A1	6/2002	Rappaport
6,554,302 B1		4/2003	Liu			2003/0006569	A1	1/2003	Combs
2001/0003392	A1	6/2001	Rappaport			2003/0090076	A1	5/2003	Beleski, Jr.
2002/0050695	A1	5/2002	Feng						

* cited by examiner

FIG. 1

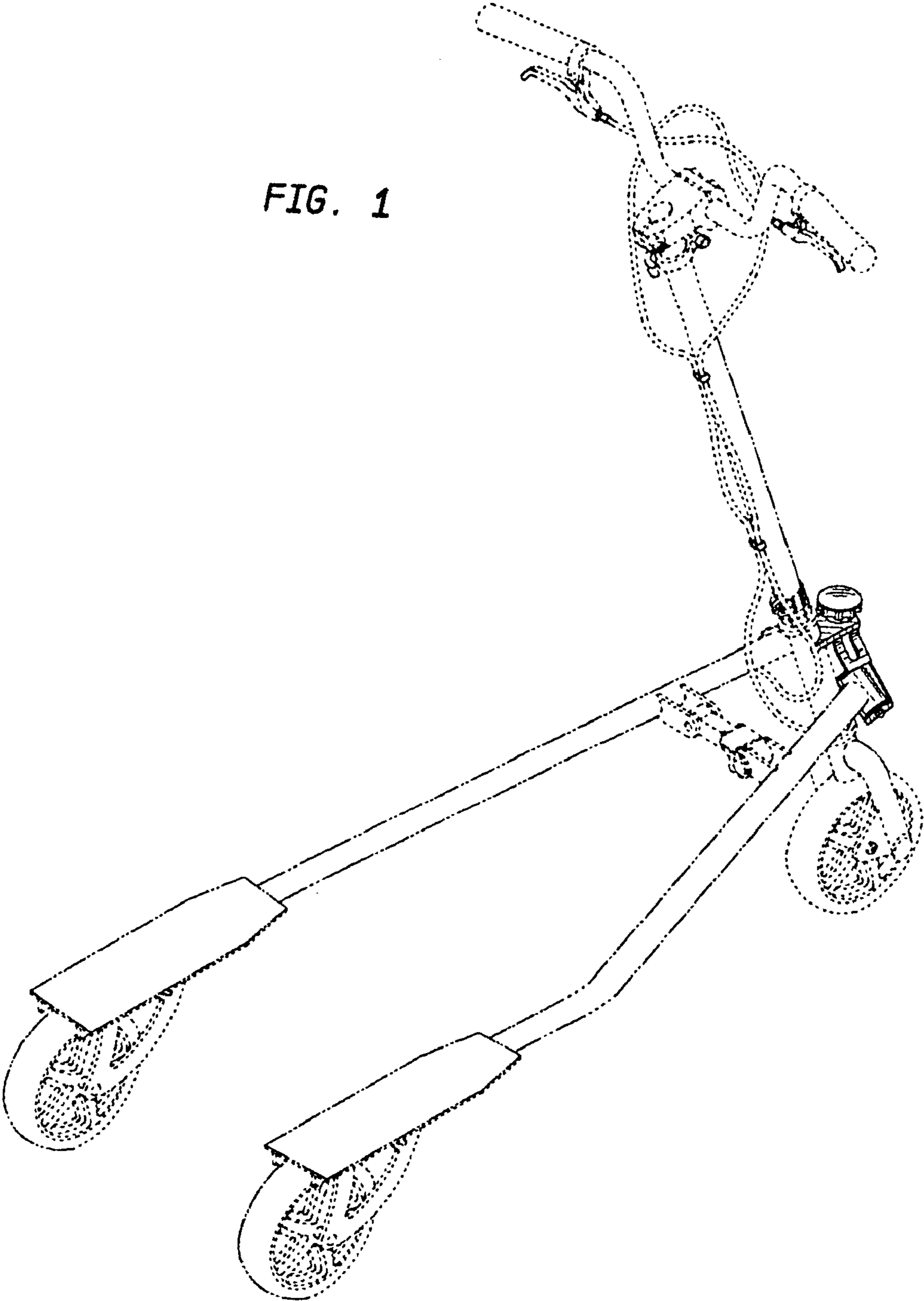

FIG. 2

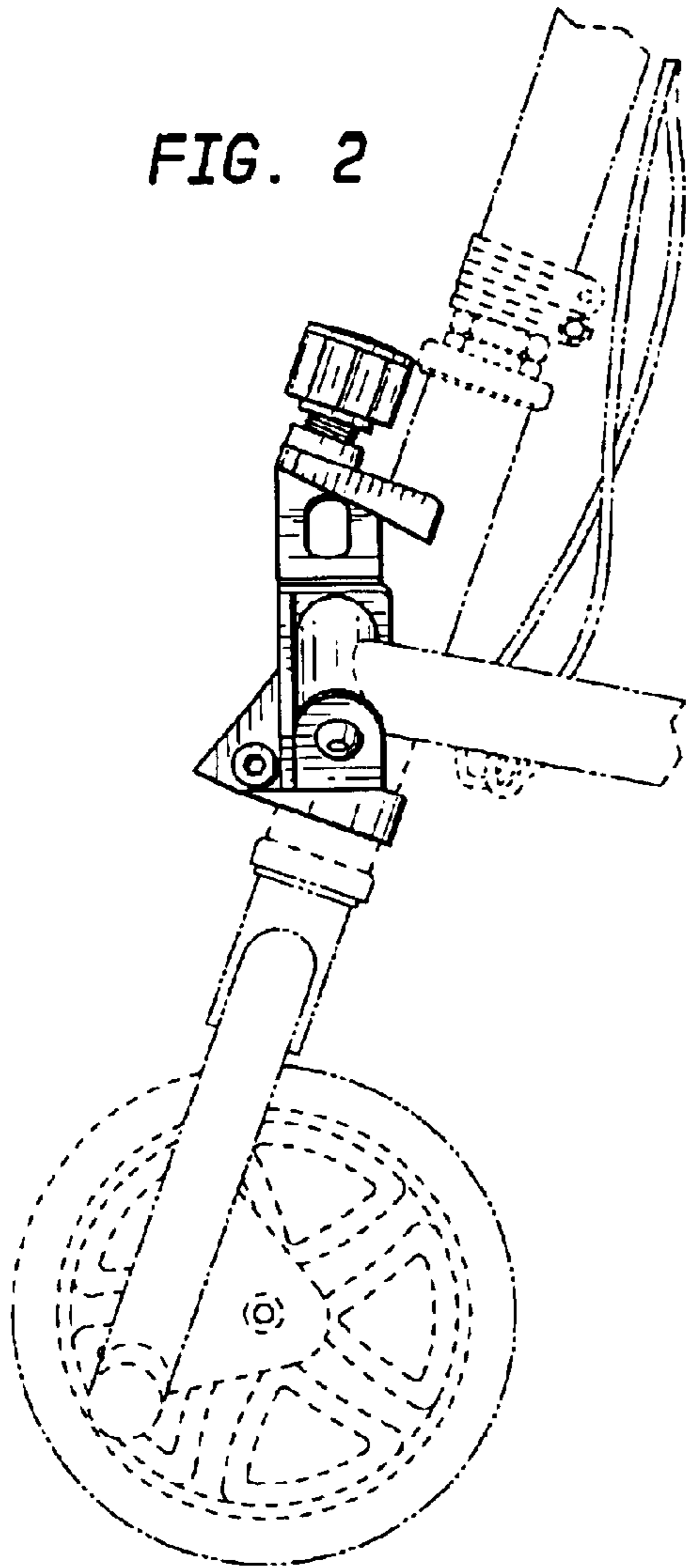

FIG. 3

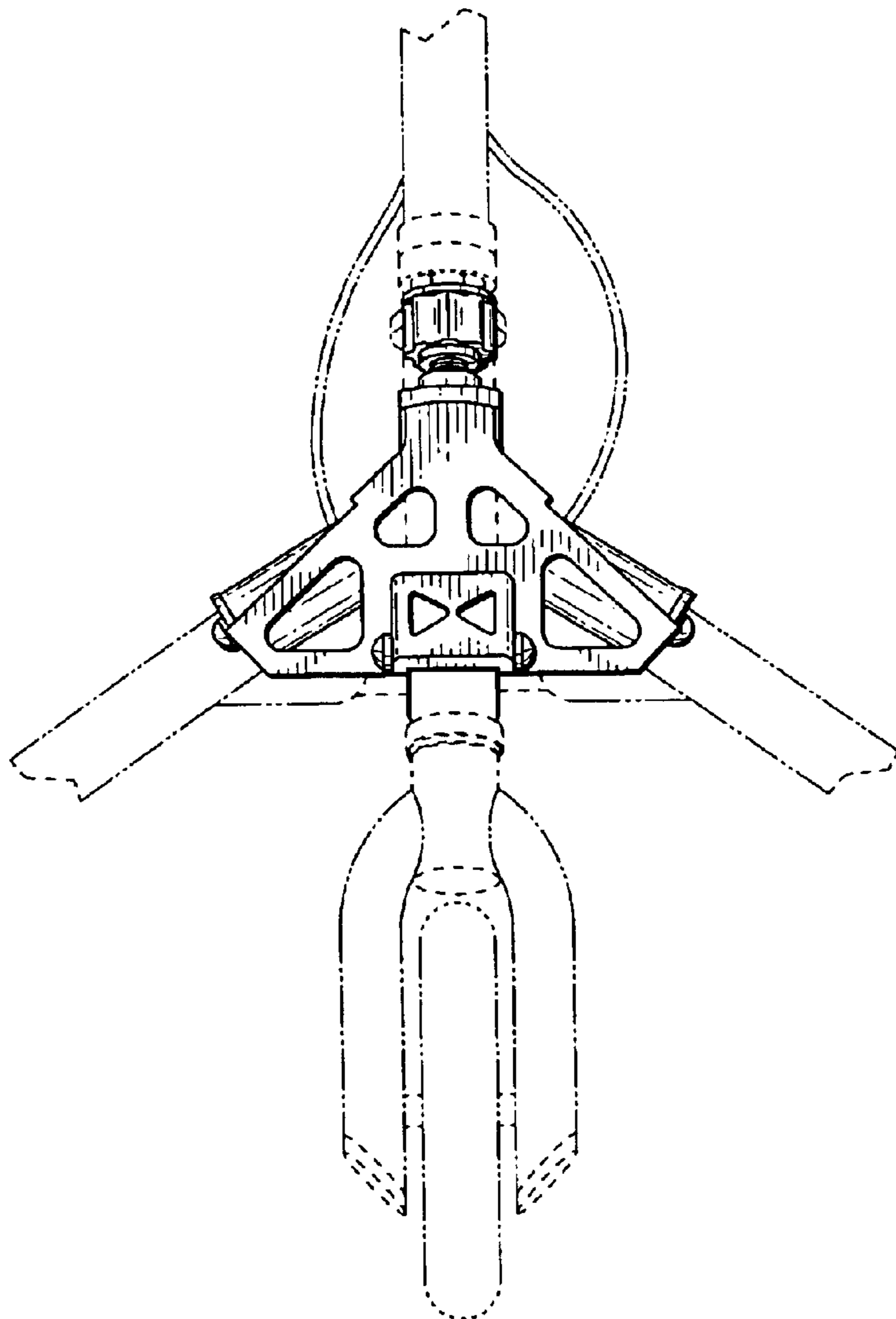

FIG. 4

