

US00D495370S1

(12) **United States Design Patent**
Loerop et al.

(10) **Patent No.: US D495,370 S**

(45) **Date of Patent: ** Aug. 31, 2004**

(54) **DISPLAY SIGN AND BASE**

(75) Inventors: **Kenneth W. Loerop**, Elmhurst, IL
(US); **Matthew Gieser**, Park Ridge, IL
(US)

(73) Assignee: **M&K Plastics Corporation**, Chicago,
IL (US)

(**) Term: **14 Years**

(21) Appl. No.: **29/187,176**

(22) Filed: **Jul. 29, 2003**

(51) **LOC (7) Cl.** **20-03**

(52) **U.S. Cl.** **D20/10**

(58) **Field of Search** D20/10, 15, 13-19,
D20/21, 43, 99; D14/374-5; 40/307, 331,
382, 607, 661

(56) **References Cited**

U.S. PATENT DOCUMENTS

D305,647 S	*	1/1990	Kato et al.	D14/374
D326,847 S	*	6/1992	Savio	D14/375
D346,594 S	*	5/1994	Skaggs et al.	D14/375
D357,468 S	*	4/1995	Rodd	D14/375

D380,498 S	*	7/1997	Lunetta	D20/10
D388,467 S	*	12/1997	Casiello	D20/43
D458,969 S	*	6/2002	Lakin	D20/10
D479,659 S	*	9/2003	Fleckenstein et al.	D6/470

* cited by examiner

Primary Examiner—Robert M. Spear

(74) *Attorney, Agent, or Firm*—McAndrews, Held & Malloy, Ltd.

(57) **CLAIM**

The ornamental design for a display sign and base, as shown and described.

DESCRIPTION

FIG. 1 is a top perspective view of a display sign and base. FIG. 2 is a bottom perspective view of the sign of FIG. 1. FIG. 3 is a side view of the sign of FIG. 1. FIG. 4 is a front view of the sign of FIG. 1. FIG. 5 is a top view of the sign of FIG. 1. FIG. 6 is a rear view of the sign of FIG. 1; and, FIG. 7 is a bottom view of the sign of FIG. 1. The broken line showing of advertising indicia is for illustrative purposes only and forms no part of the claimed design.

1 Claim, 2 Drawing Sheets

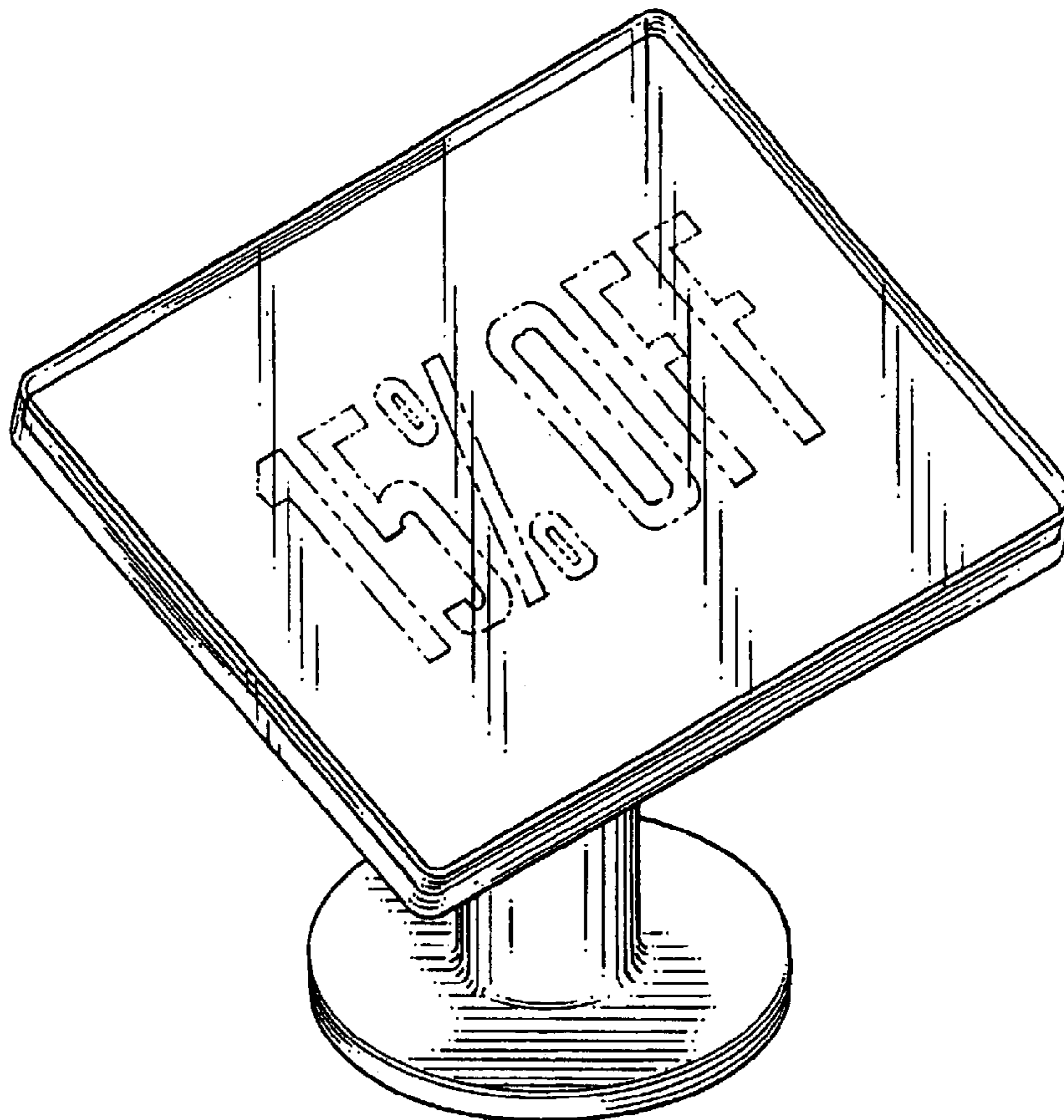

FIG.1

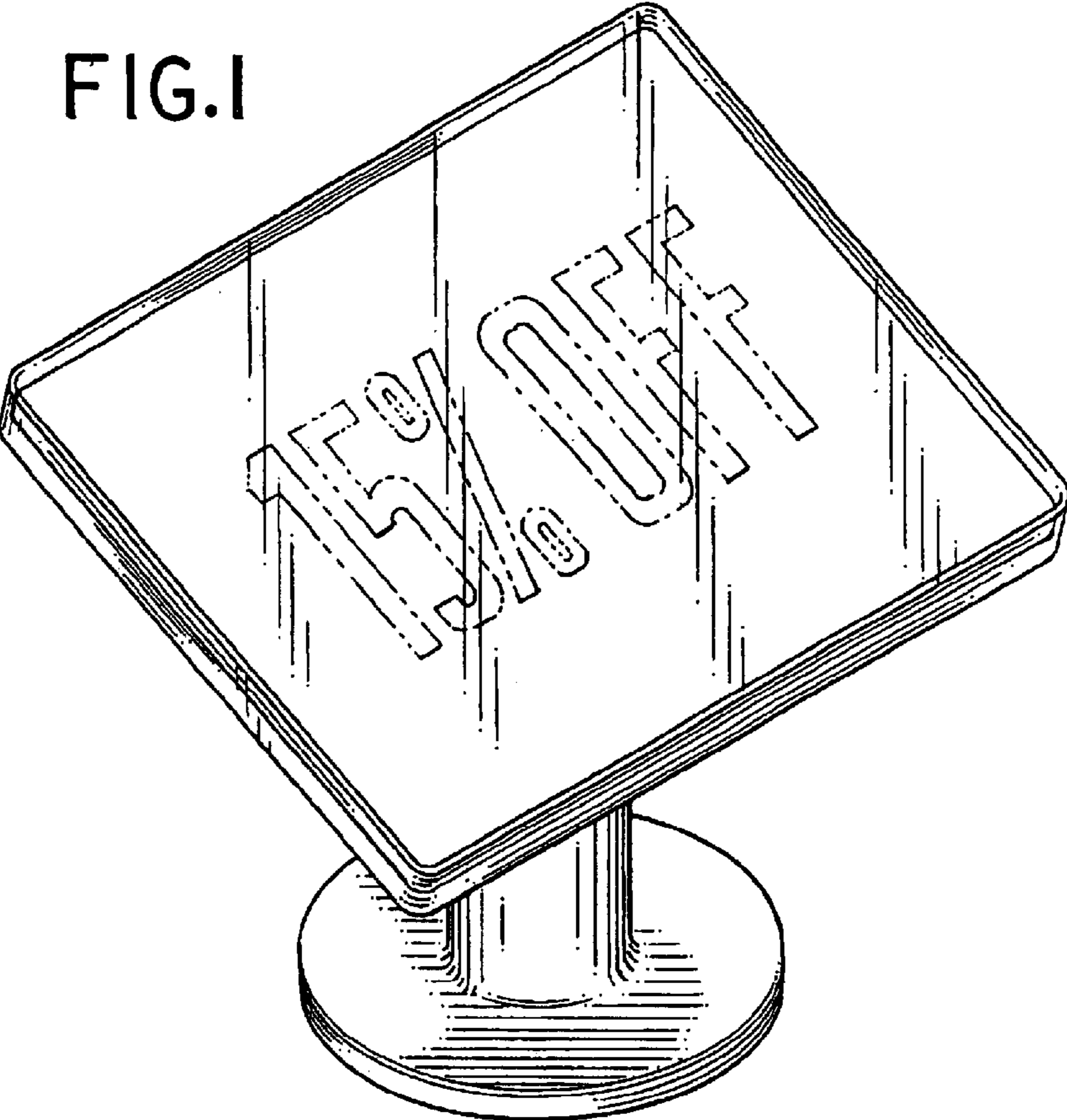

FIG.2

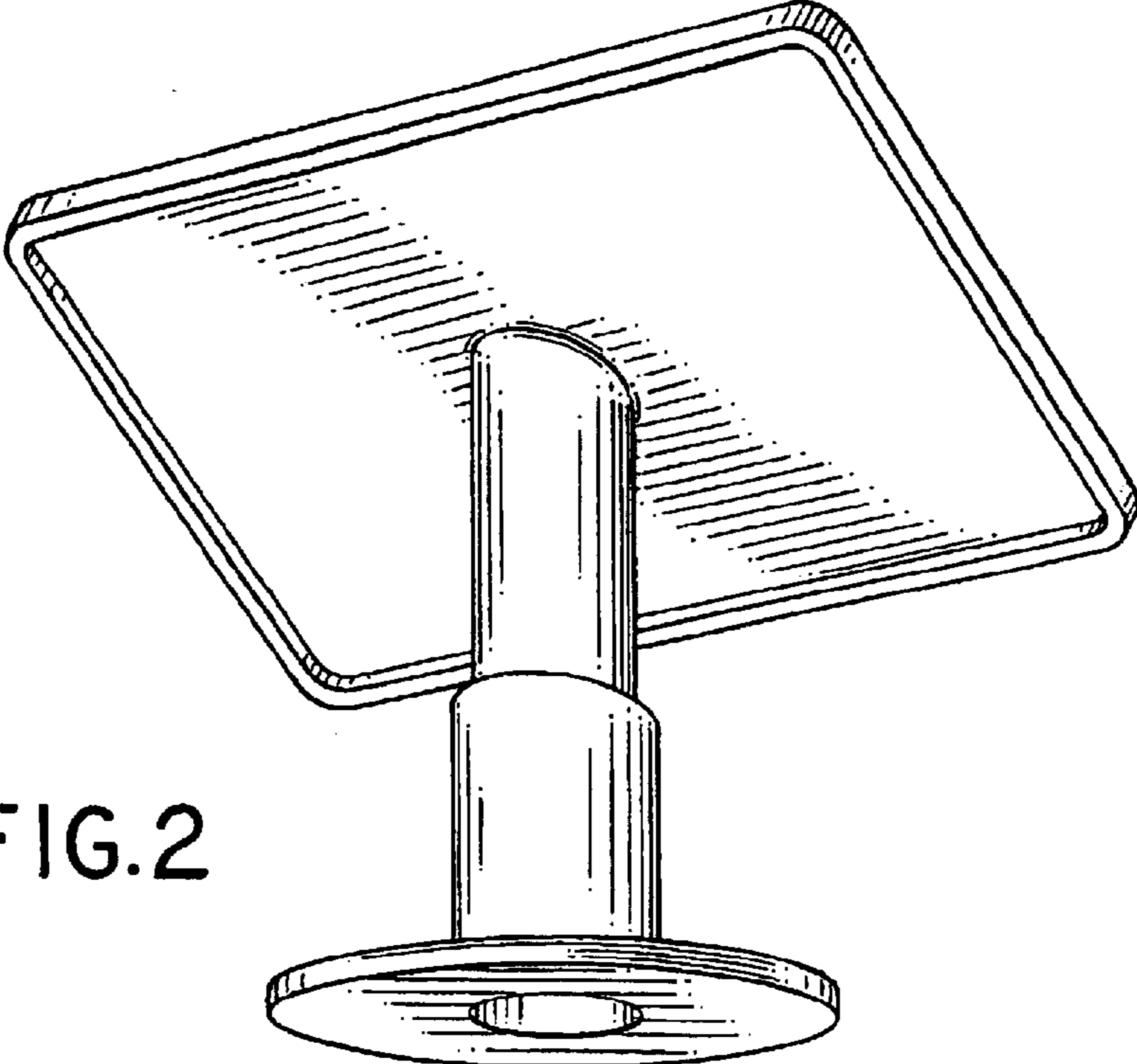

FIG.3

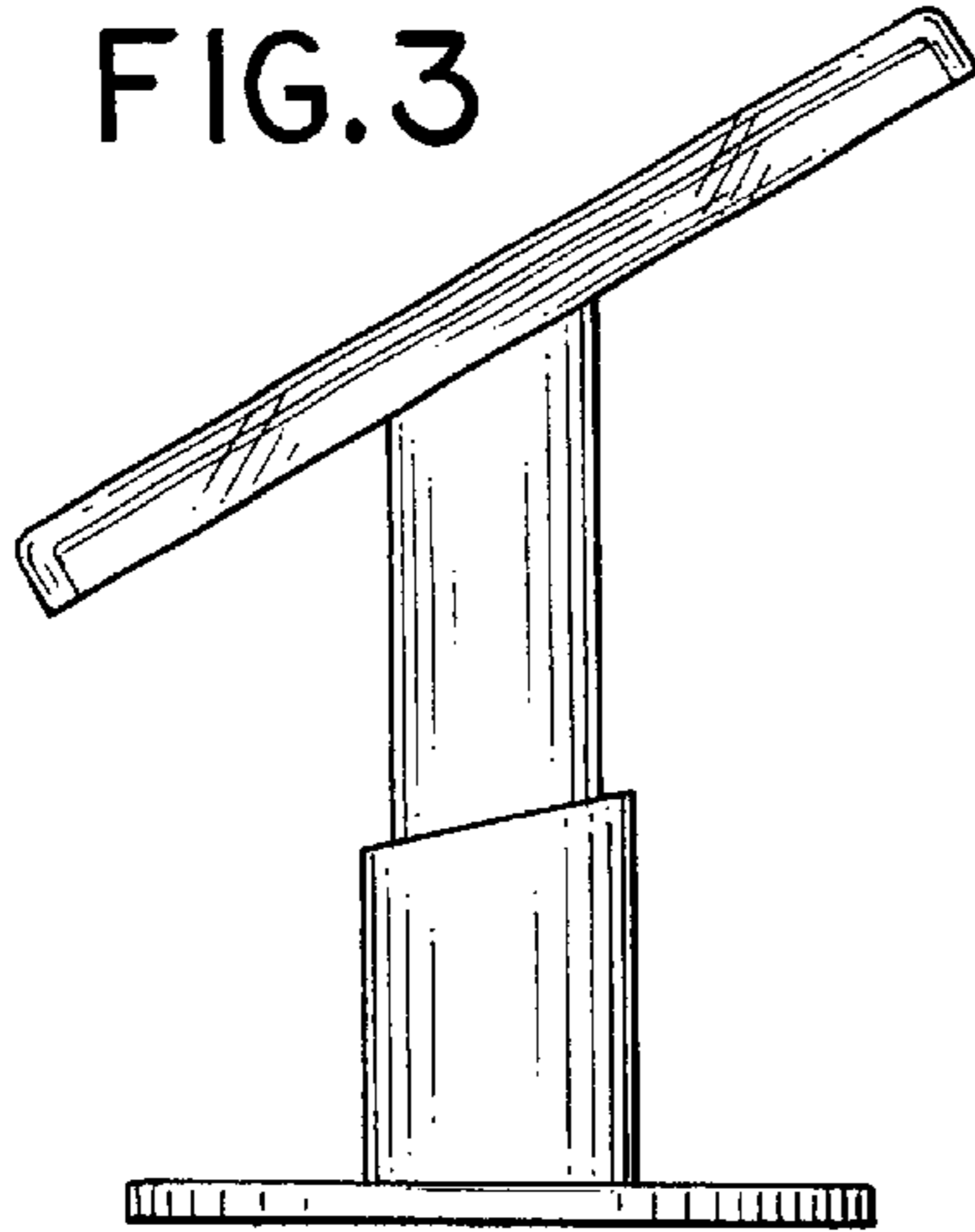

FIG.4

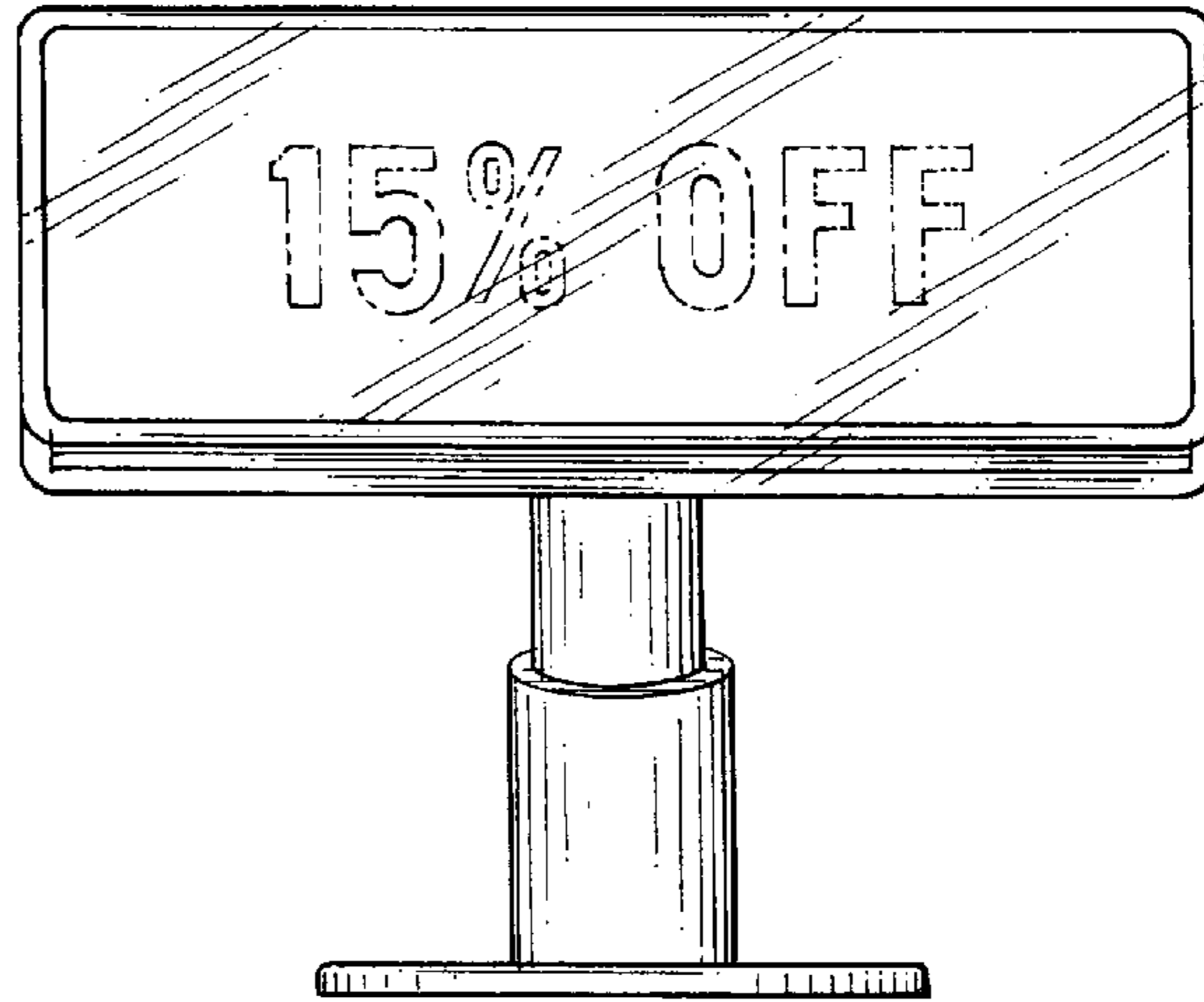

FIG.5



FIG.6

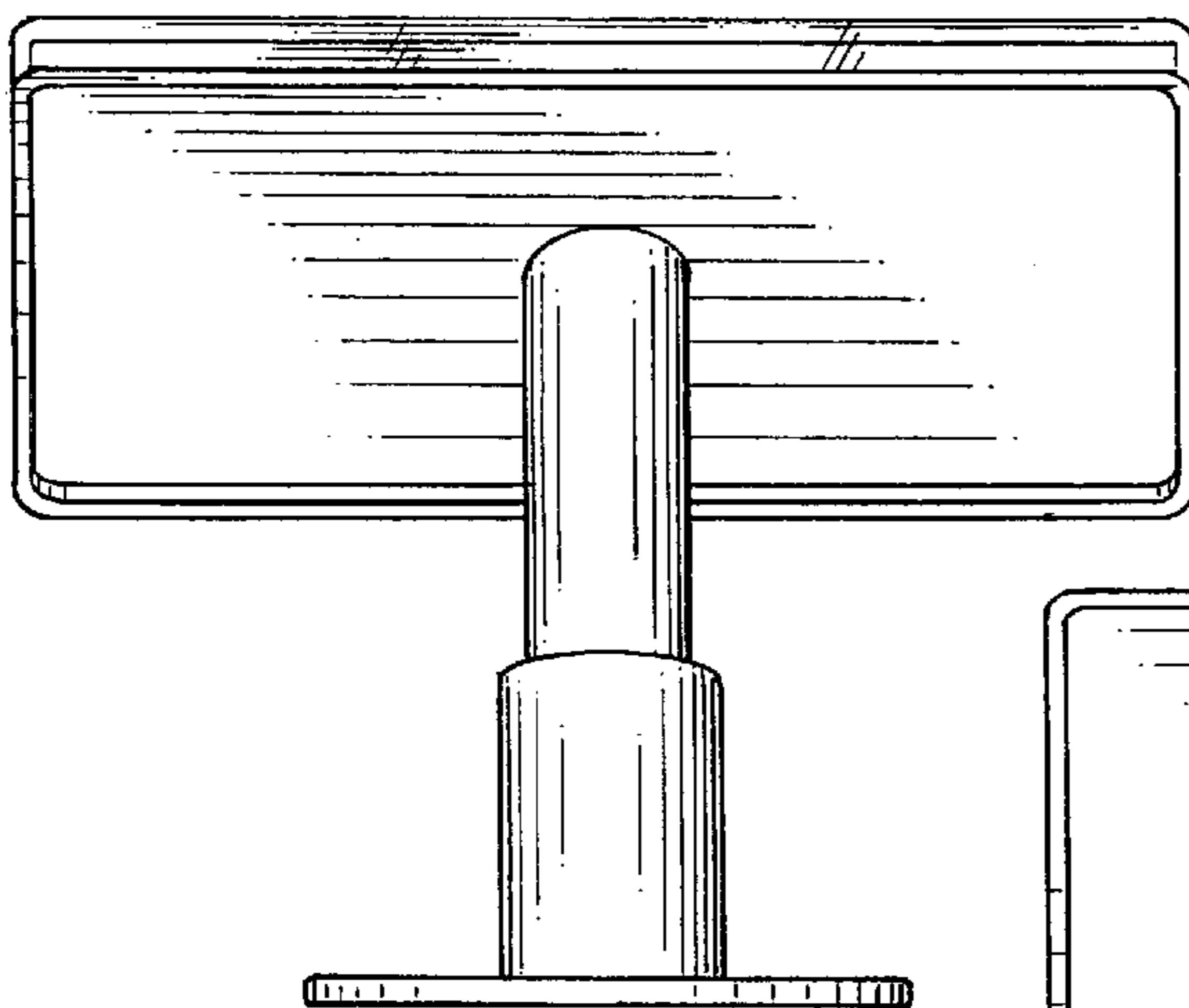

FIG.7

