

US00D495086S1

(12) **United States Design Patent**  
**Burkart et al.**

(10) **Patent No.: US D495,086 S**

(45) **Date of Patent: \*\* Aug. 24, 2004**

(54) **LANTERN CAP**

D484,631 S \* 12/2003 Chen ..... D26/67  
2003/0189834 A1 \* 10/2003 Hsing ..... 362/363

(75) Inventors: **Michael Burkart**, Denver, CO (US);  
**Scott A. Wilson**, Frederick, CO (US)

\* cited by examiner

(73) Assignee: **Stallion Fence Accessories**, Denver,  
CO (US)

*Primary Examiner*—Jennifer Rivard  
(74) *Attorney, Agent, or Firm*—Marsh Fischmann &  
Breyfogle LLP

(\*\*) Term: **14 Years**

(57) **CLAIM**

(21) Appl. No.: **29/193,553**

The ornamental design for a lantern cap, as shown and  
described.

(22) Filed: **Nov. 10, 2003**

**DESCRIPTION**

(51) **LOC (7) Cl.** ..... **26-99**

(52) **U.S. Cl.** ..... **D26/113**

(58) **Field of Search** ..... D26/67, 85, 113,  
D26/118; 362/359, 360, 362, 363, 367,  
431

FIG. 1 is a top perspective view of the cap;  
FIG. 2 is a bottom perspective view of the cap;  
FIG. 3 is a top plan view of the cap;  
FIG. 4 is a bottom plan view of the cap;  
FIG. 5 is a plan view of a first side of the cap;  
FIG. 6 is a plan view of a second side of the cap; and,  
FIG. 7 is a perspective the cap on a lantern lens assembly.  
The broken lines are shown for illustrative purposes only  
and form no part of the claimed design.

(56) **References Cited**

**U.S. PATENT DOCUMENTS**

D326,728 S \* 6/1992 Layne ..... D26/67  
D469,559 S \* 1/2003 Chang ..... D26/67

**1 Claim, 4 Drawing Sheets**

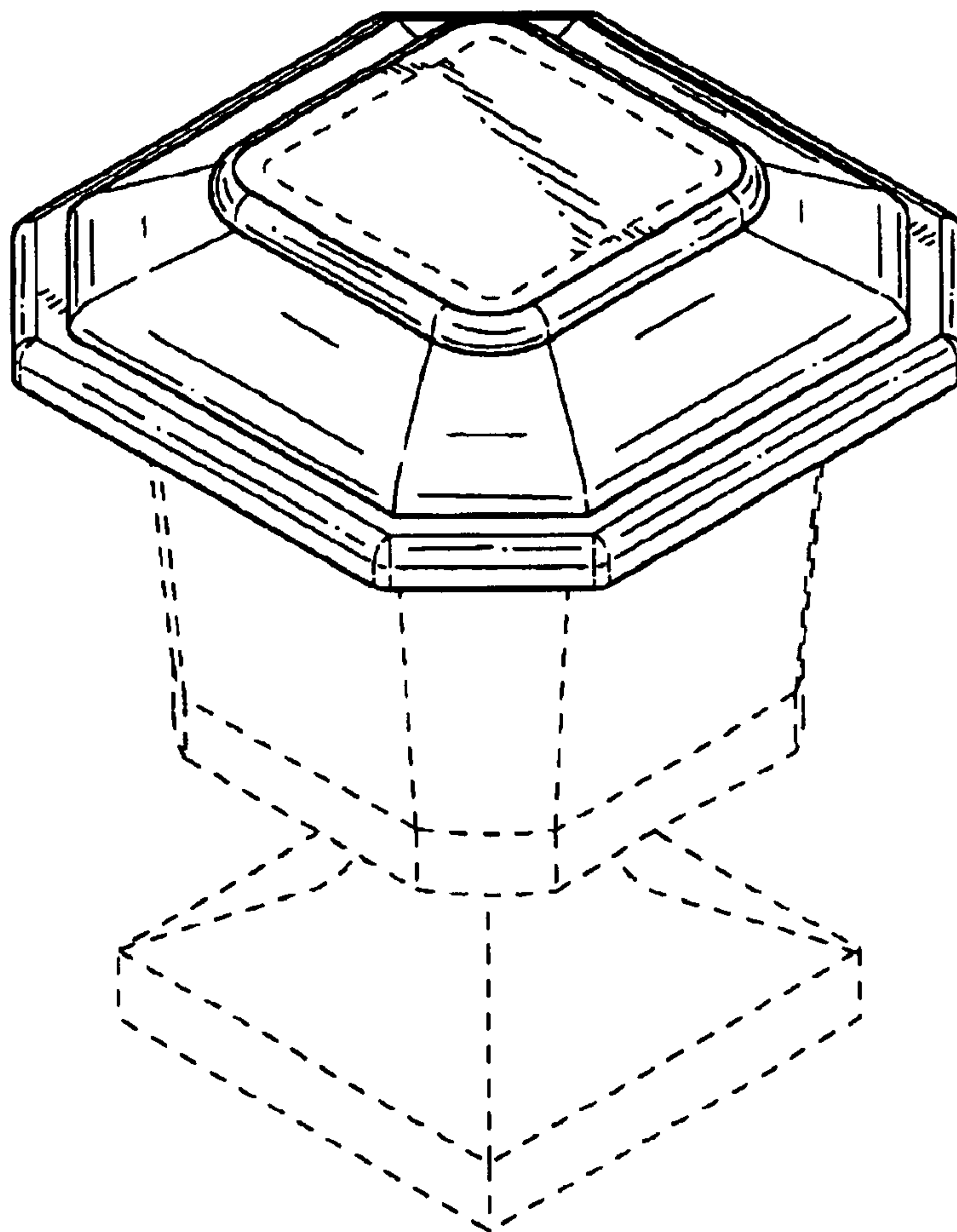

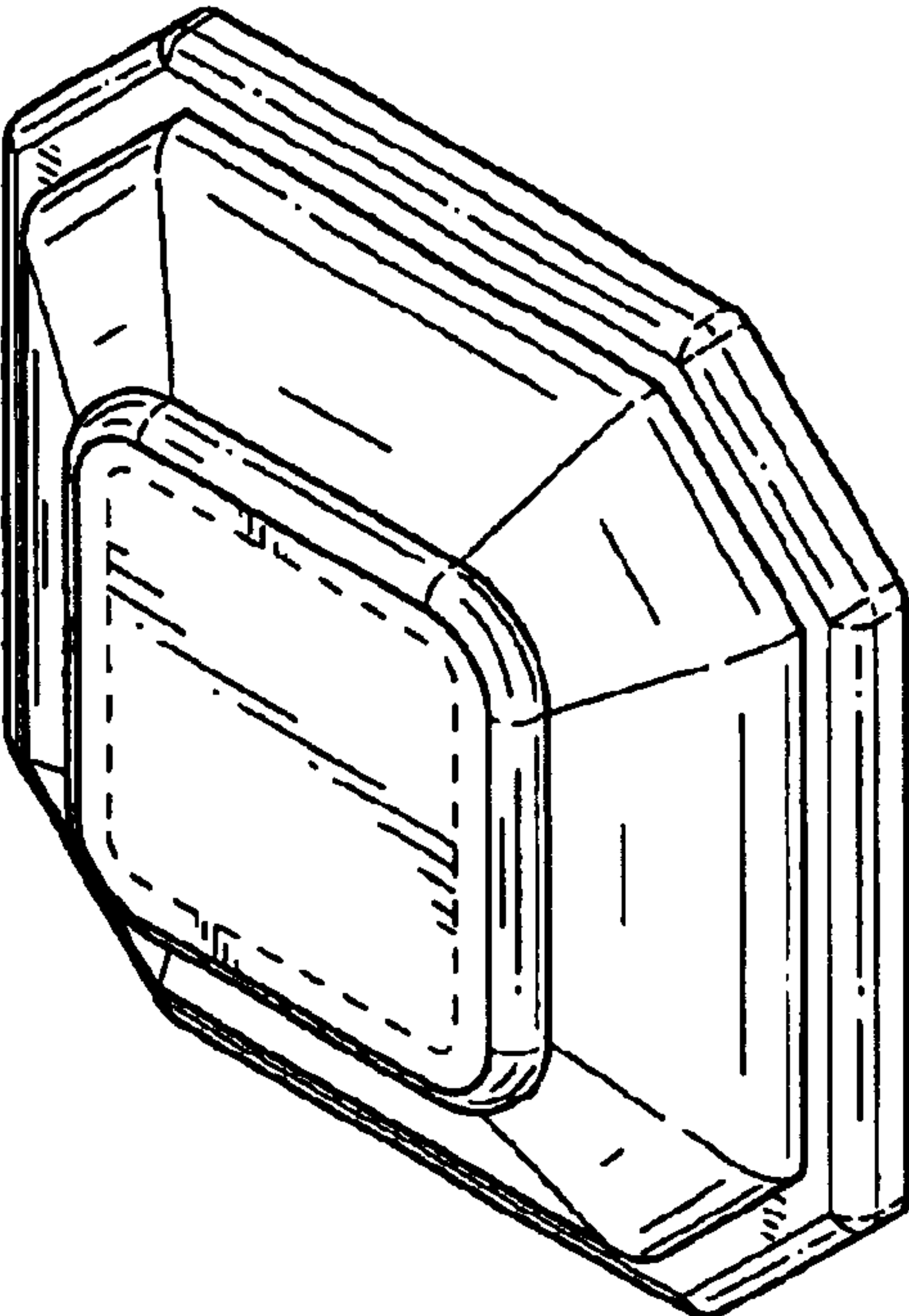

FIG.1

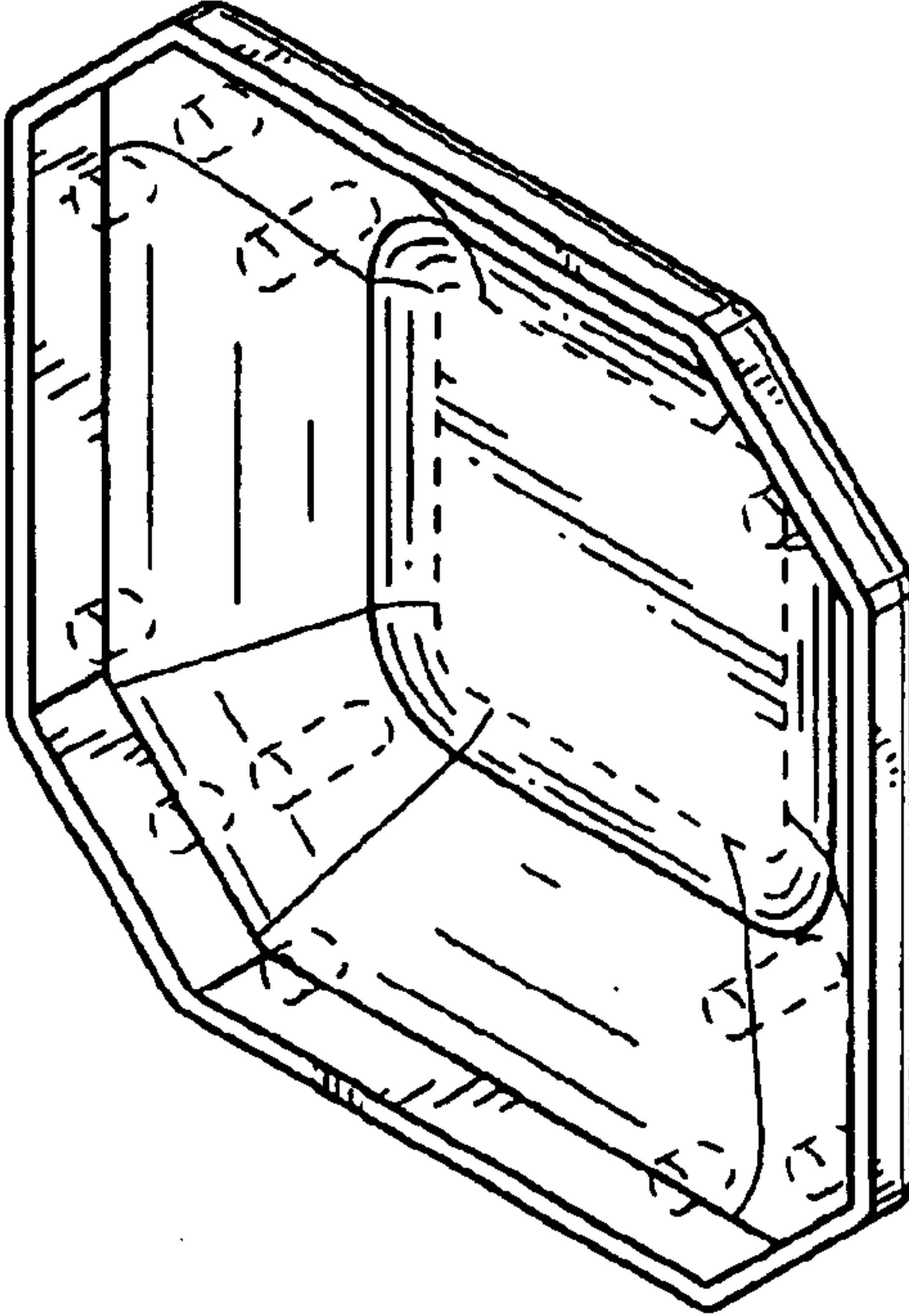

FIG.2

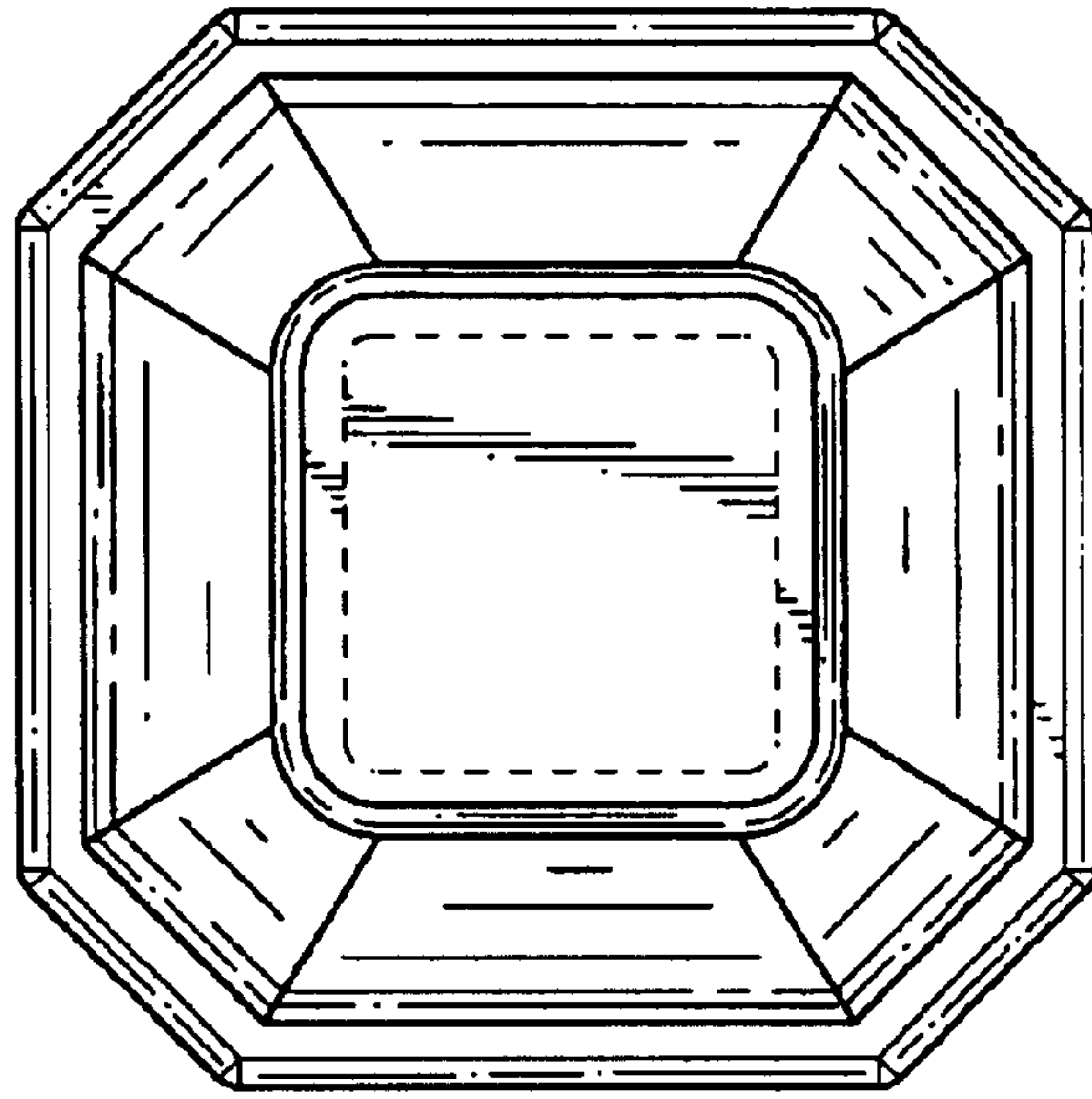

FIG.3

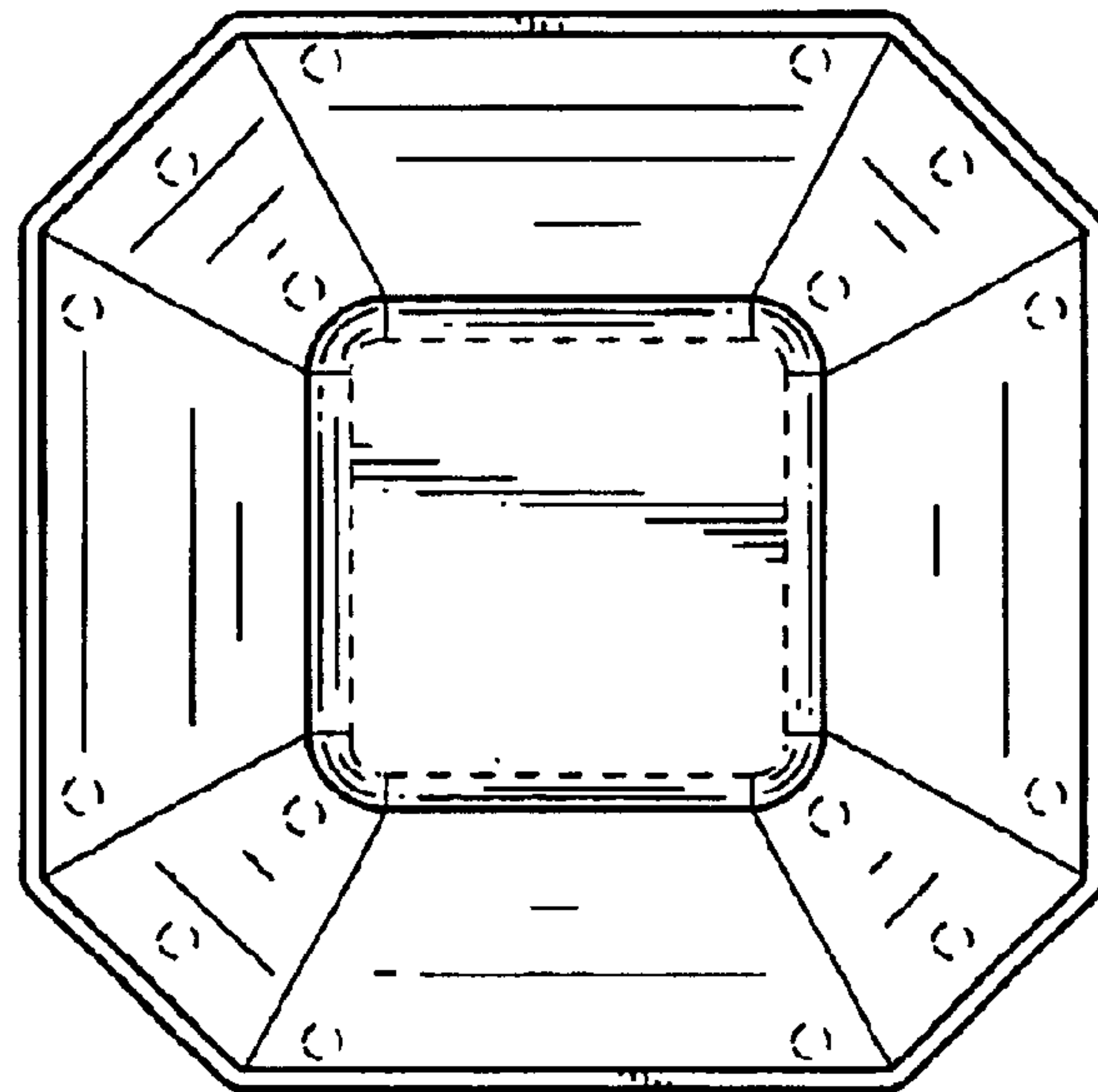

FIG.4

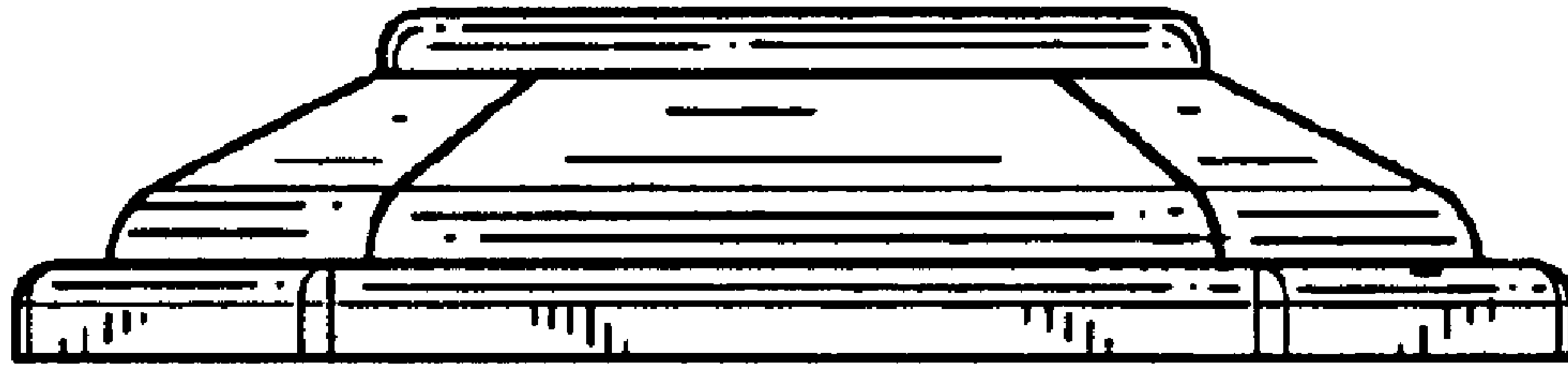

FIG. 5

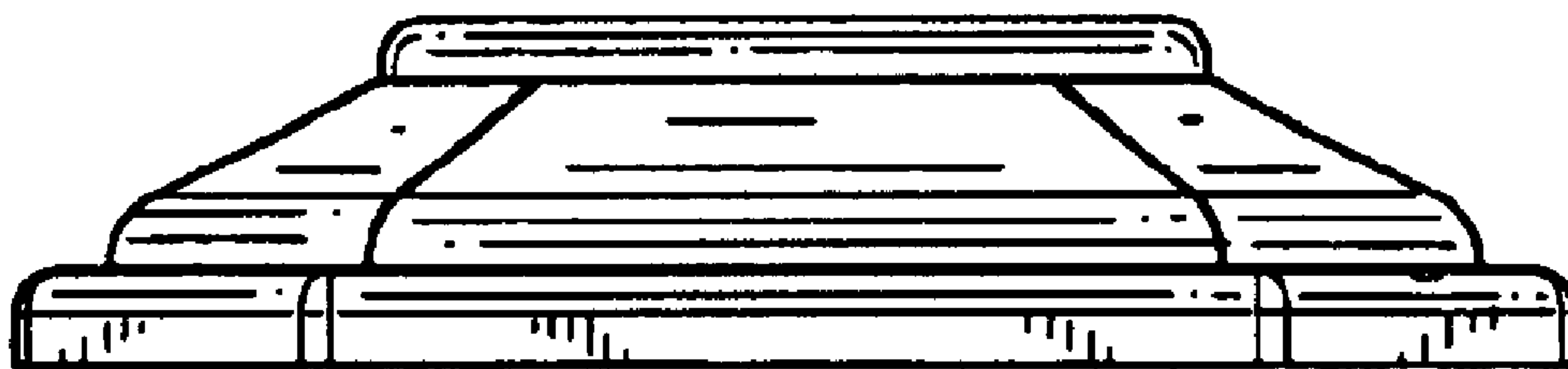

FIG. 6

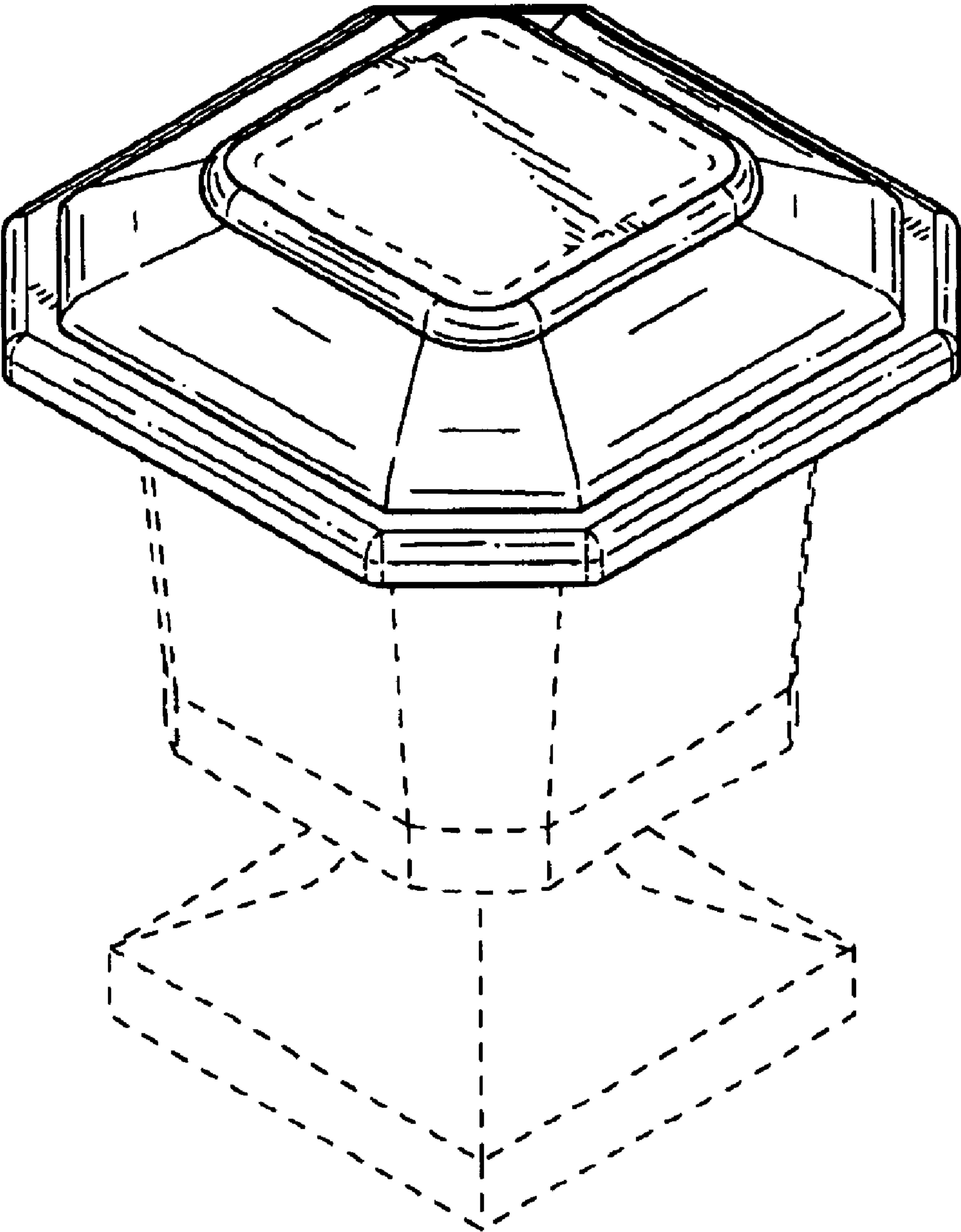

FIG.7