



US00D495031S1

(12) **United States Design Patent**  
**Taylor**

(10) **Patent No.:** **US D495,031 S**

(45) **Date of Patent:** **\*\* Aug. 24, 2004**

(54) **PILOT VALVE HOUSING**

(75) **Inventor:** **Julian S. Taylor**, Oklahoma City, OK  
(US)

(73) **Assignee:** **Taylor Innovations, L.L.C.**, Oklahoma  
City, OK (US)

(\*\*) **Term:** **14 Years**

(21) **Appl. No.:** **29/182,007**

(22) **Filed:** **May 19, 2003**

(51) **LOC (7) Cl.** ..... **23-01**

(52) **U.S. Cl.** ..... **D23/233**

(58) **Field of Search** ..... D23/233-249;  
137/115.19, 596.14; 251/50

(56) **References Cited**

**U.S. PATENT DOCUMENTS**

2,507,384 A \* 5/1950 Schneck ..... 137/474  
D160,365 S \* 10/1950 Brumbaugh ..... D23/246  
D270,752 S \* 9/1983 Gorans ..... D23/248

D414,844 S \* 10/1999 Lynch et al. .... D23/245  
D419,642 S \* 1/2000 Hiramatsu et al. .... D23/233  
6,125,886 A \* 10/2000 Sagawa et al. .... 137/625.69  
D442,259 S \* 5/2001 Takada et al. .... D23/233  
D460,148 S \* 7/2002 Hayashi et al. .... D23/233

\* cited by examiner

*Primary Examiner*—Nelson C. Holtje

(74) *Attorney, Agent, or Firm*—Fellers, Snider, et al.

(57) **CLAIM**

The ornamental design for a pilot valve housing, as shown.

**DESCRIPTION**

FIG. 1 is a perspective view of a pilot valve housing showing  
my new design;

FIG. 2 is a right side elevational view thereof;

FIG. 3 is a left side elevational view thereof;

FIG. 4 is a top plan view thereof;

FIG. 5 is a bottom plan view thereof;

FIG. 6 is a front elevational view thereof; and,

FIG. 7 is a rear elevational view thereof.

**1 Claim, 2 Drawing Sheets**

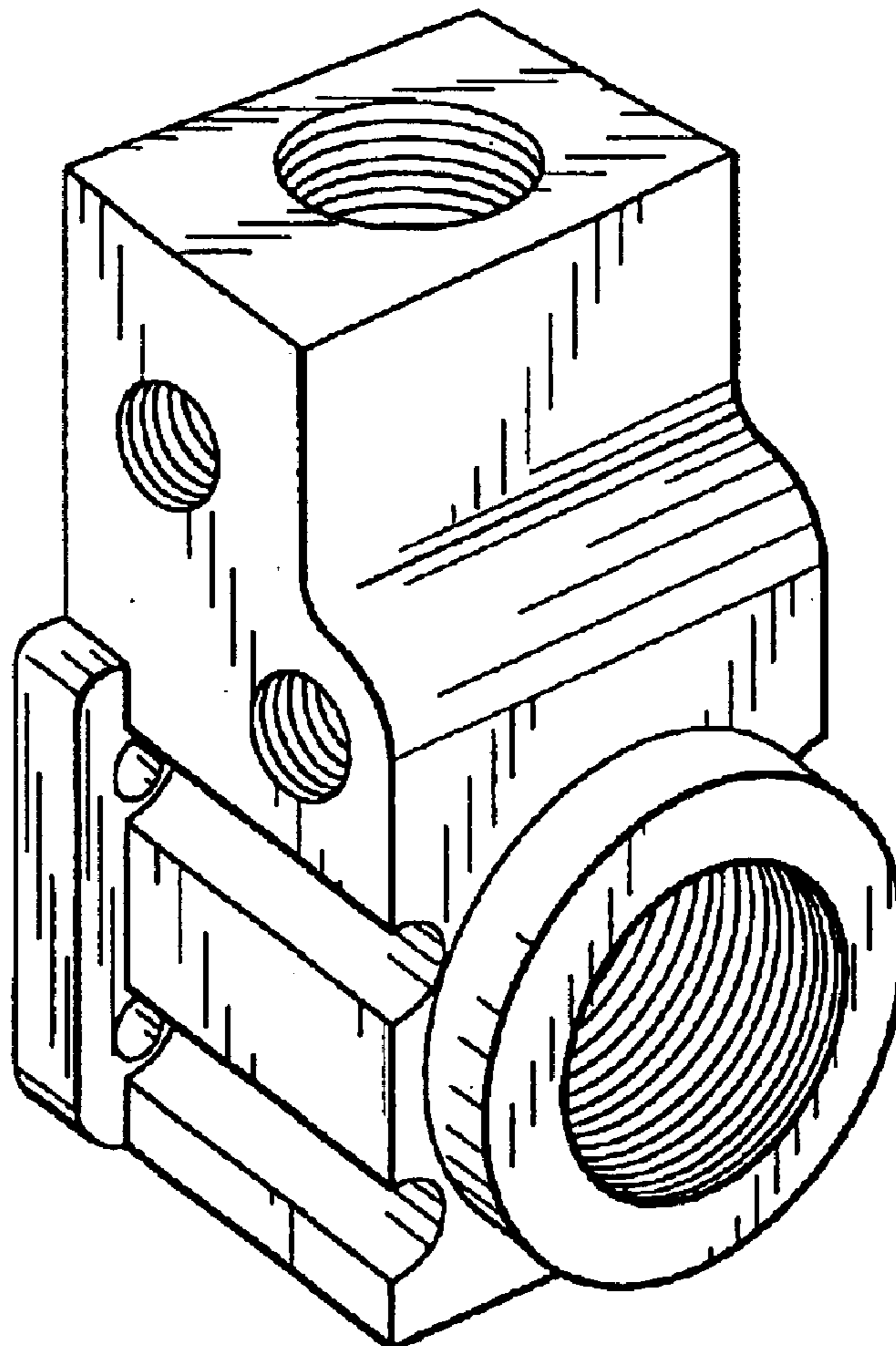

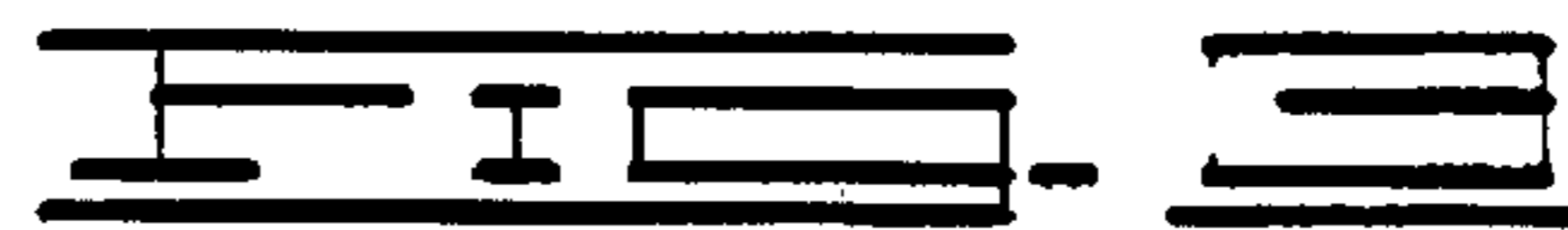
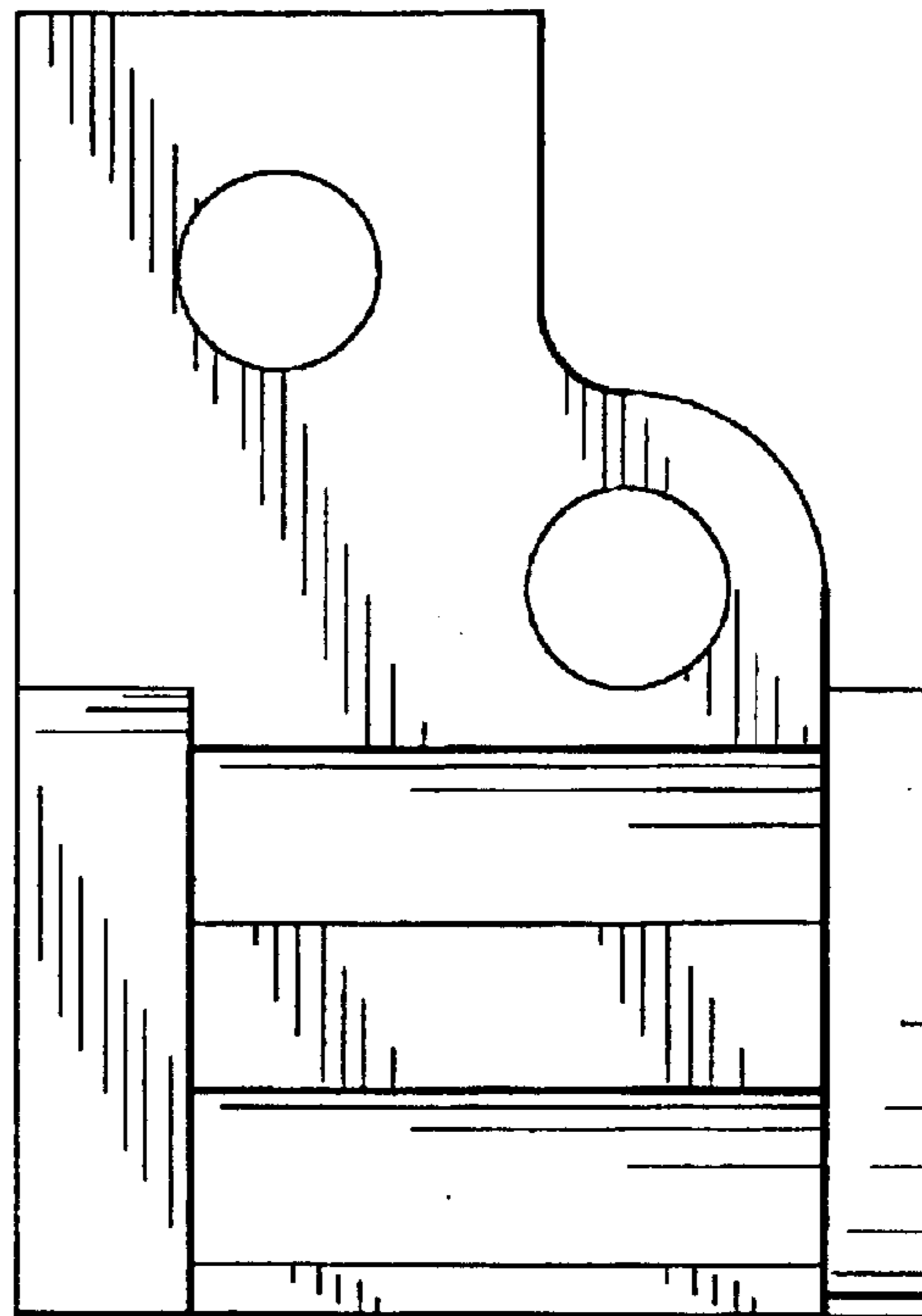
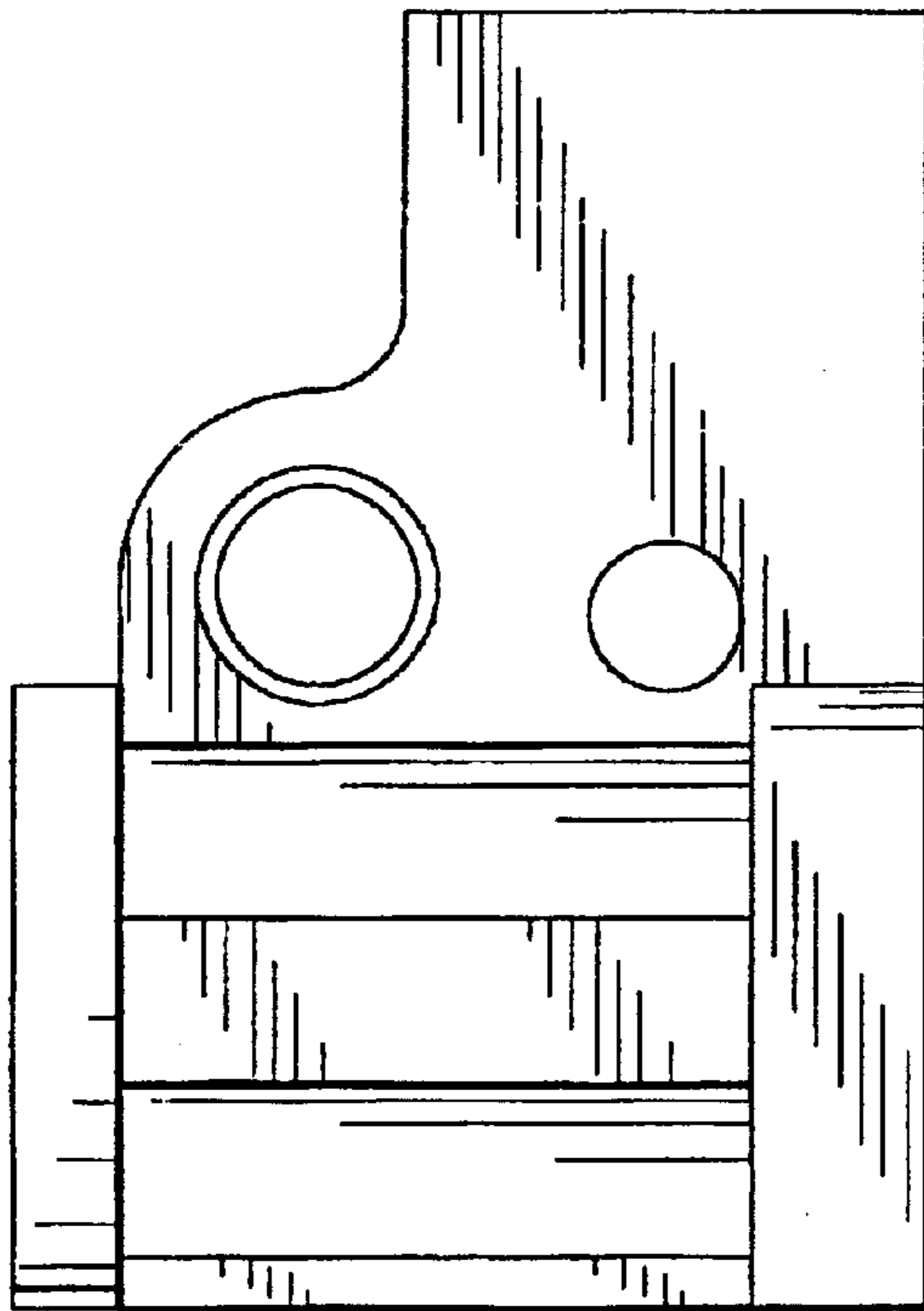
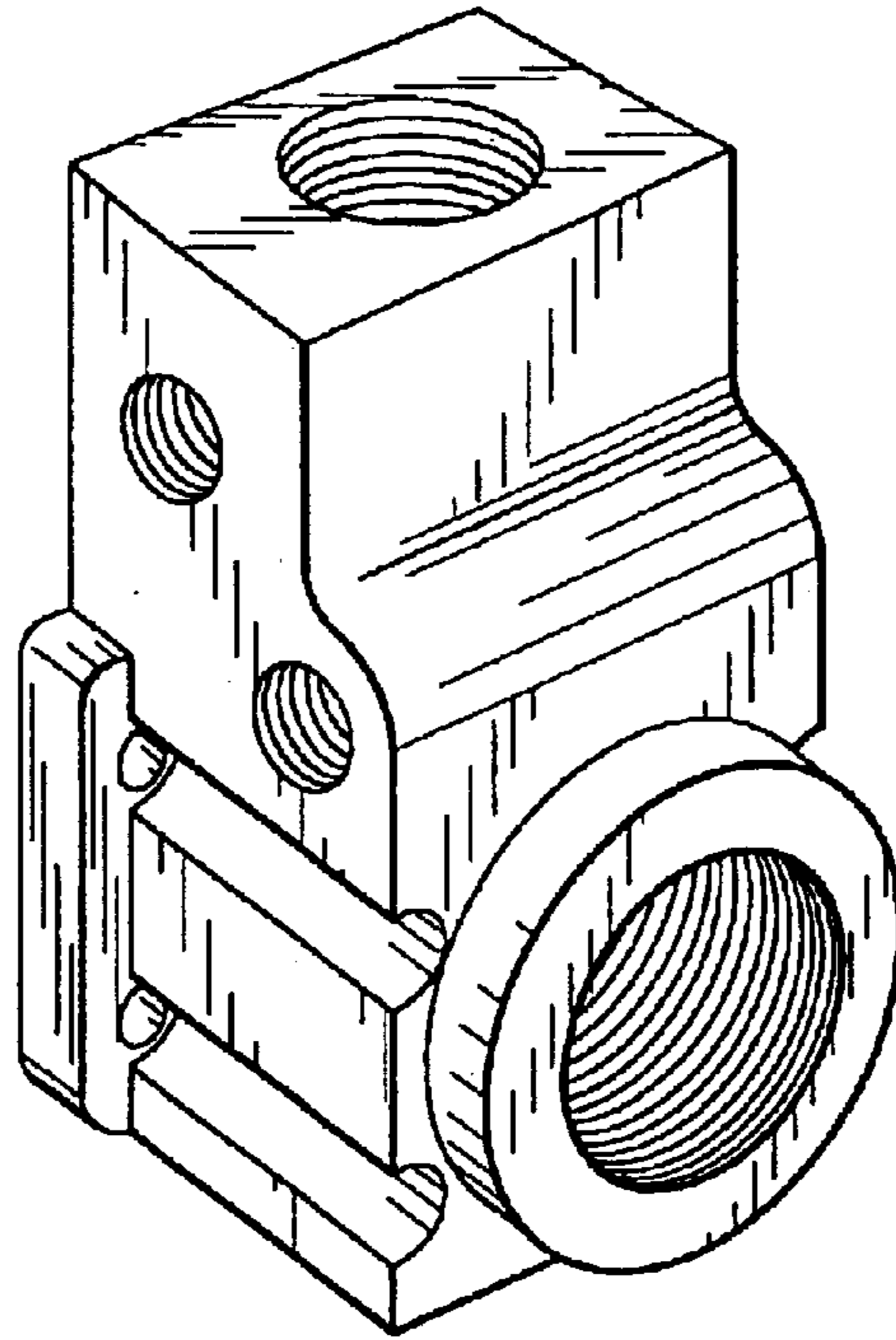

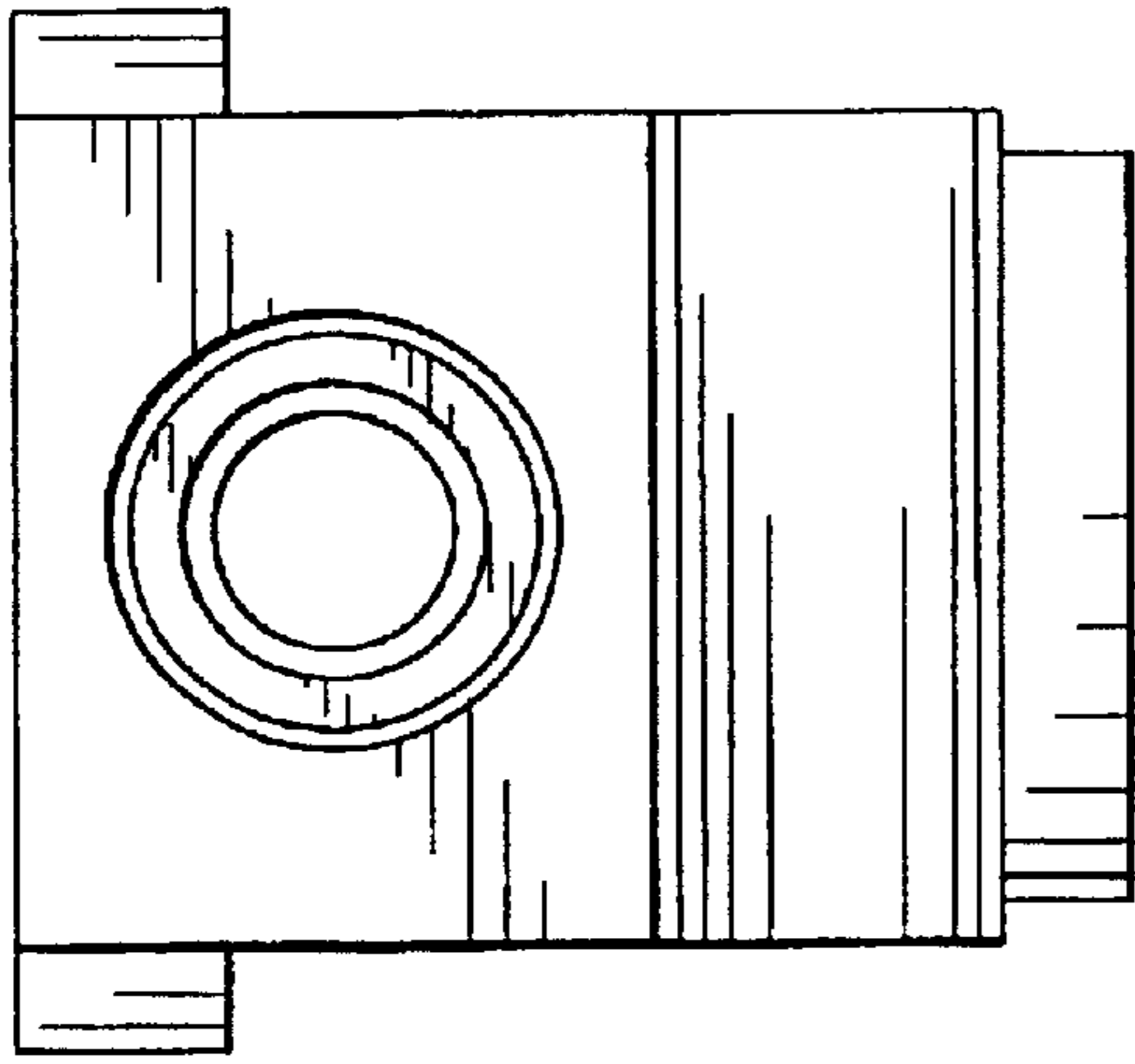

FIG. 4

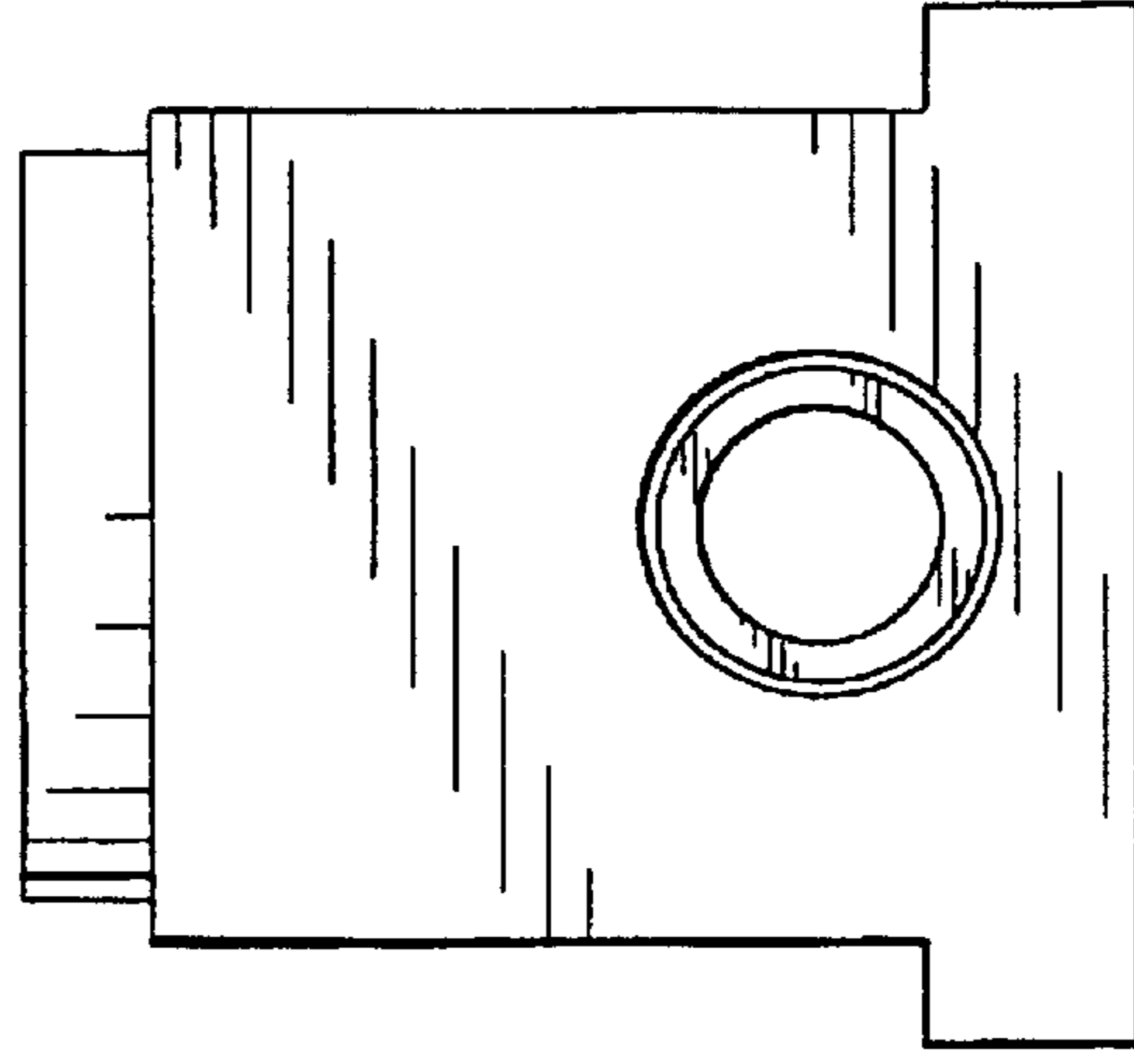

FIG. 5

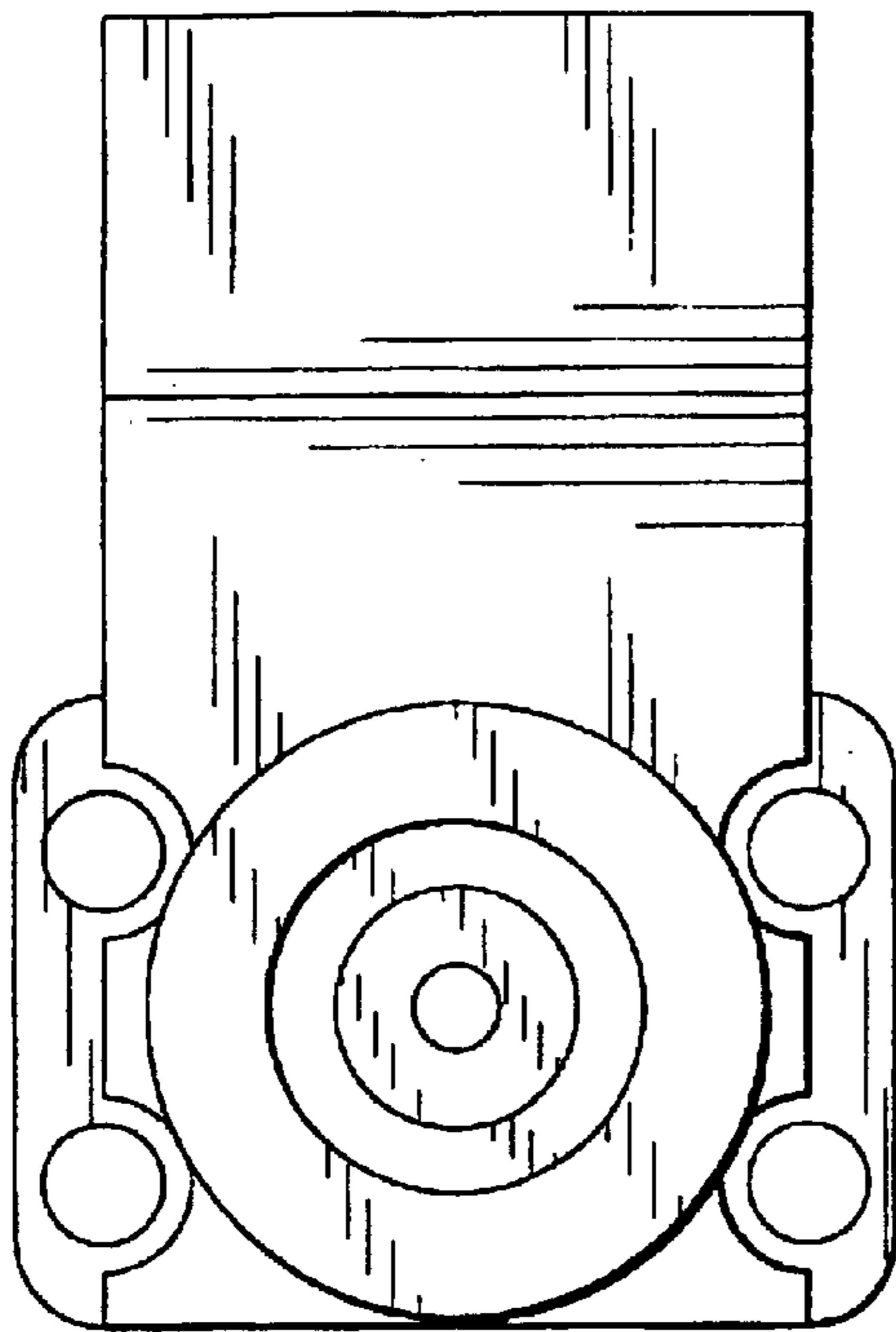

FIG. 6

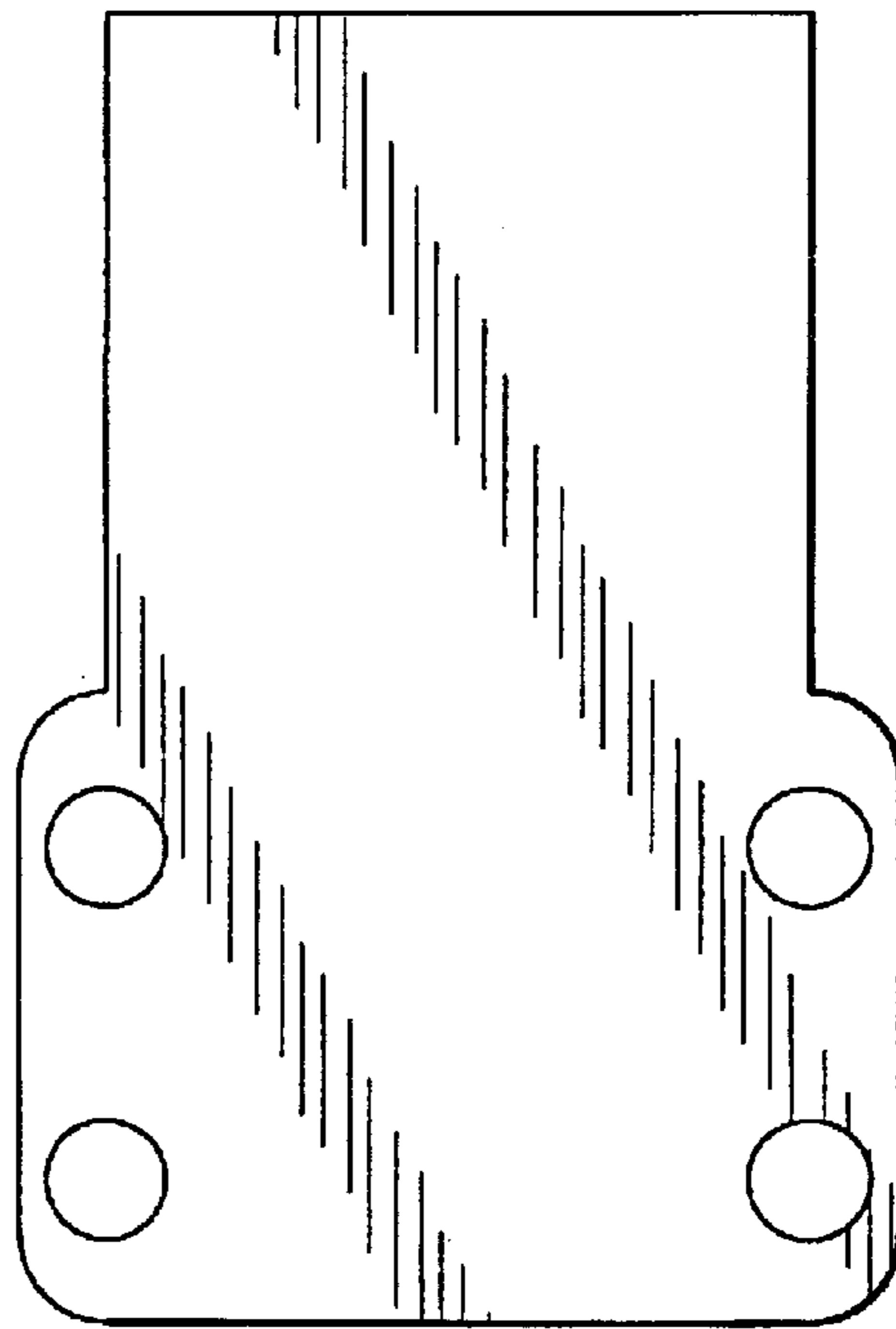

FIG. 7