

US00D494986S1

(12) **United States Design Patent**  
**Tokach et al.**

(10) **Patent No.:** **US D494,986 S**  
(45) **Date of Patent:** **\*\* Aug. 24, 2004**

(54) **MINI-EXCAVATOR CAB EXTERIOR**

D436,605 S \* 1/2001 Shaw et al. .... D15/30  
6,170,180 B1 1/2001 Schaeff ..... 37/443  
6,357,231 B1 3/2002 Duppong ..... 60/421

(75) Inventors: **Thomas J. Tokach**, Mandan, ND (US);  
**Michael D. Wetzel**, Bismarck, ND  
(US); **Henry J. Weber**, Bismarck, ND  
(US); **Troy D. Kraft**, Wahpeton, ND  
(US)

\* cited by examiner

*Primary Examiner*—Mitchell Siegel  
(74) *Attorney, Agent, or Firm*—Westman, Champlin &  
Kelly, P.A.

(73) Assignee: **Clark Equipment Company**,  
Woodcliff, NJ (US)

(57) **CLAIM**

(\*\*) Term: **14 Years**

The ornamental design for a mini-excavator cab exterior, as  
shown and described.

(21) Appl. No.: **29/168,104**

**DESCRIPTION**

(22) Filed: **Sep. 26, 2002**

(51) **LOC (7) Cl.** ..... **15-03**

(52) **U.S. Cl.** ..... **D15/30**

(58) **Field of Search** ..... D15/30, 10, 22-26,  
D15/28, 31; 180/89.1, 89.12, 900; 296/190.1;  
414/680, 685, 694, 698, 719, 743

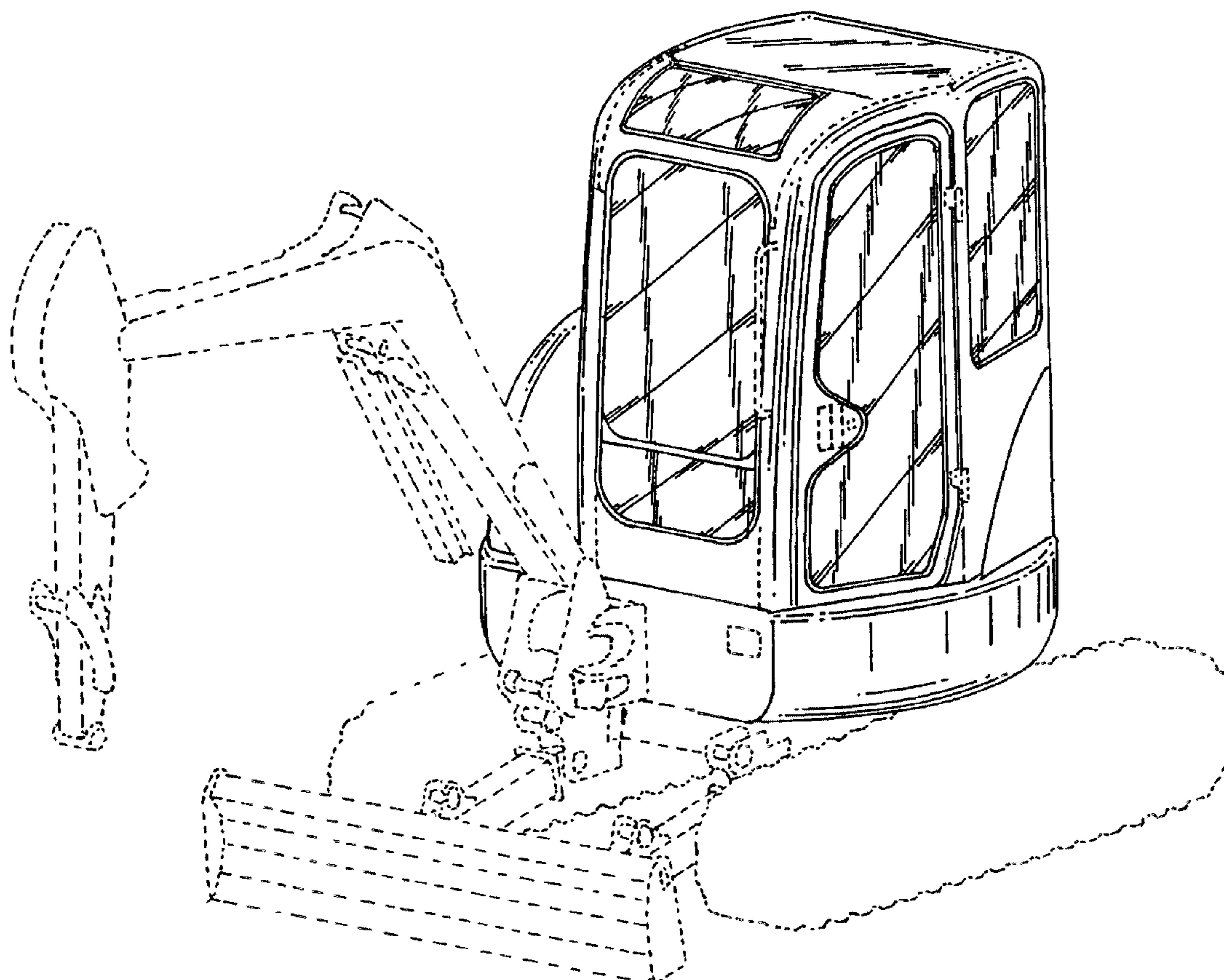
FIG. 1 is a view in perspective as seen from the front, side  
and top of a mini-excavator cab and body, with portions of  
the vehicle shown in dashed lines representing environment;  
FIG. 2 is another perspective view with environmental  
portions of the vehicle removed;  
FIG. 3 is a side elevation of the side shown in FIG. 2;  
FIG. 4 is a side elevation of the side opposite that shown in  
FIG. 3;  
FIG. 5 is a front elevational view;  
FIG. 6 is a rear elevational view;  
FIG. 7 is a top plan view; and,  
FIG. 8 is a bottom plan view.

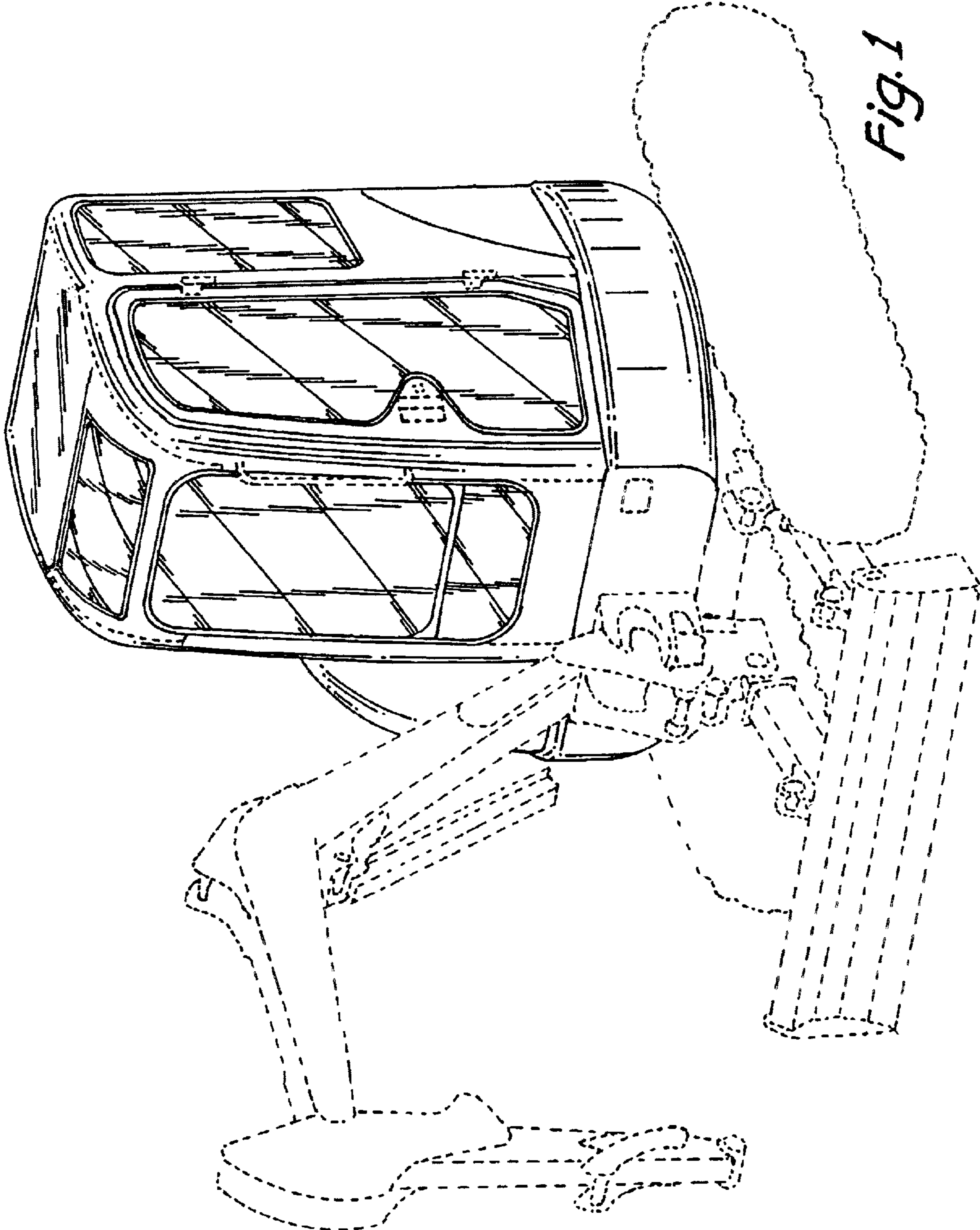
(56) **References Cited**

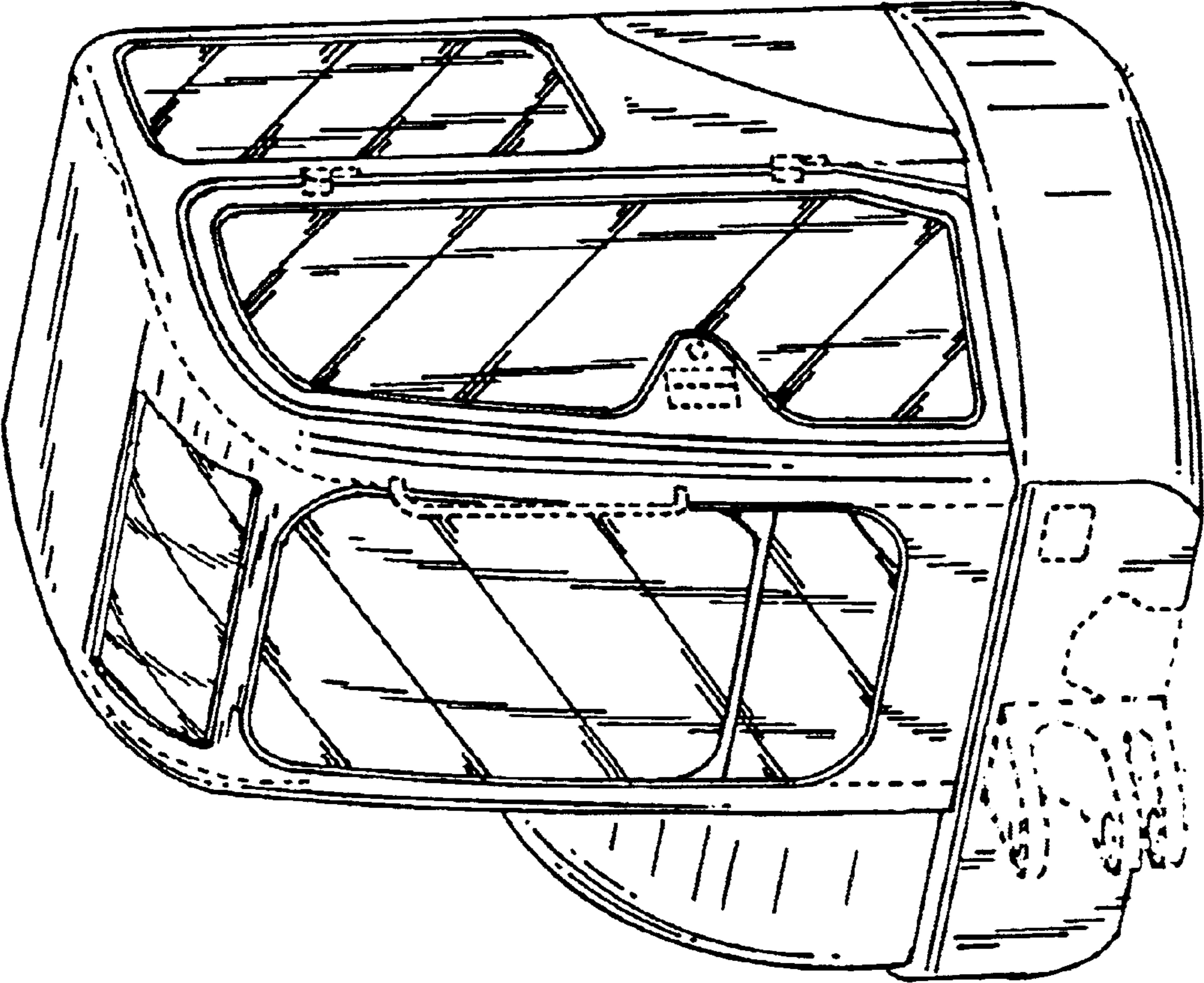
**U.S. PATENT DOCUMENTS**

5,184,933 A 2/1993 Pei-qian et al. .... 414/725  
D338,019 S \* 8/1993 Bhambra ..... D15/25  
6,018,895 A 2/2000 Duppong et al. .... 37/348  
D433,689 S \* 11/2000 Kraft et al. .... D15/30

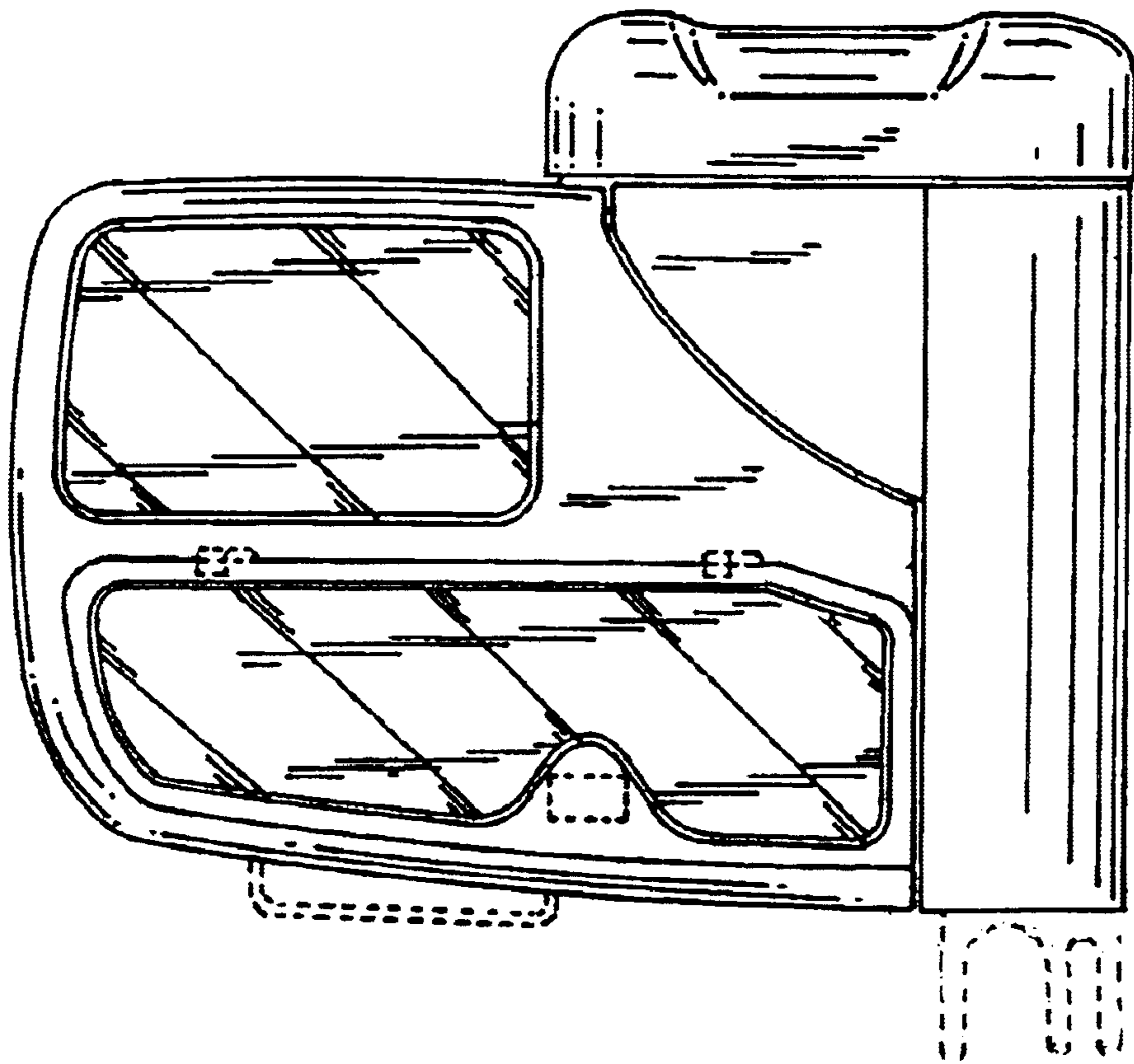
**1 Claim, 8 Drawing Sheets**





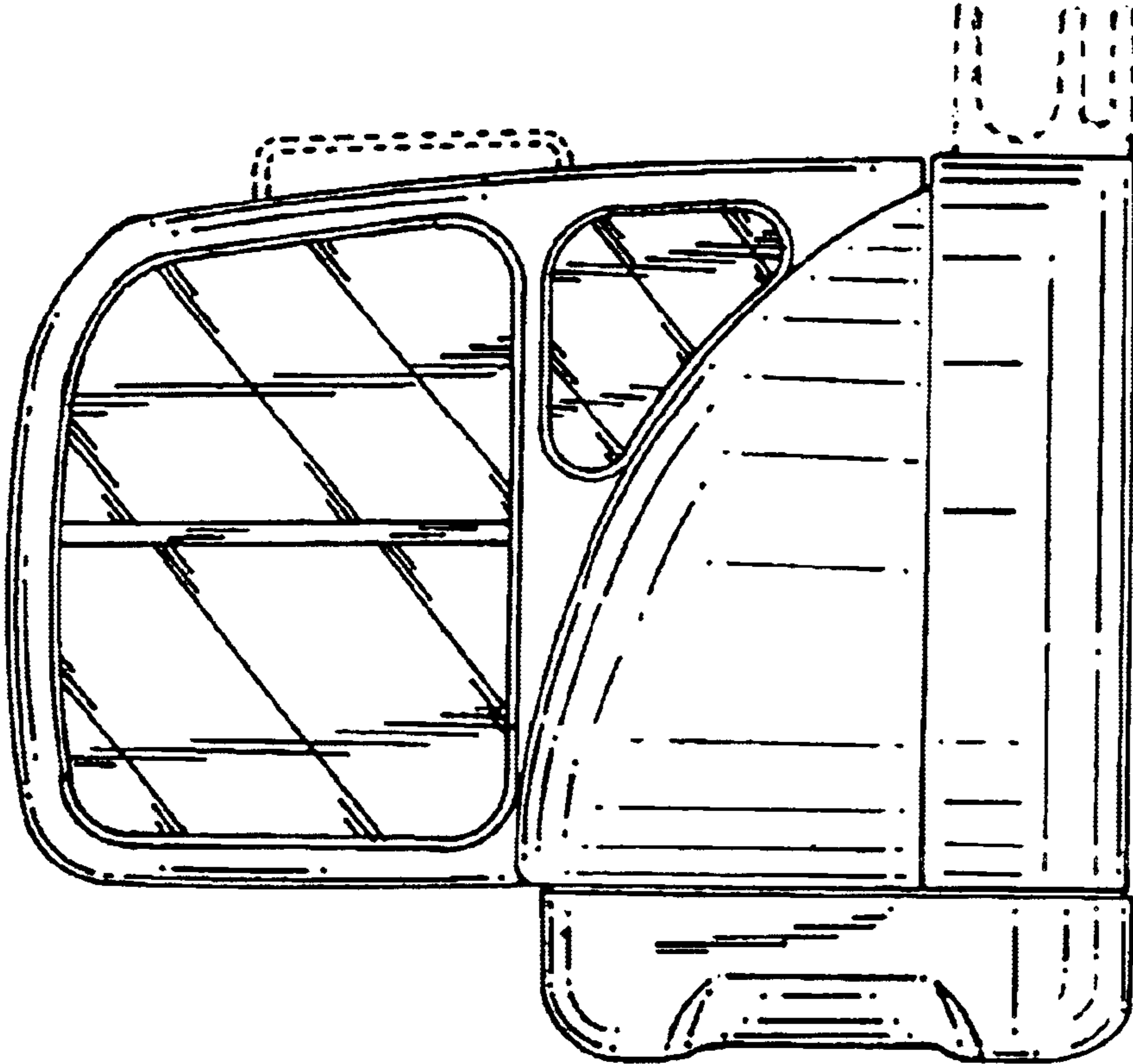


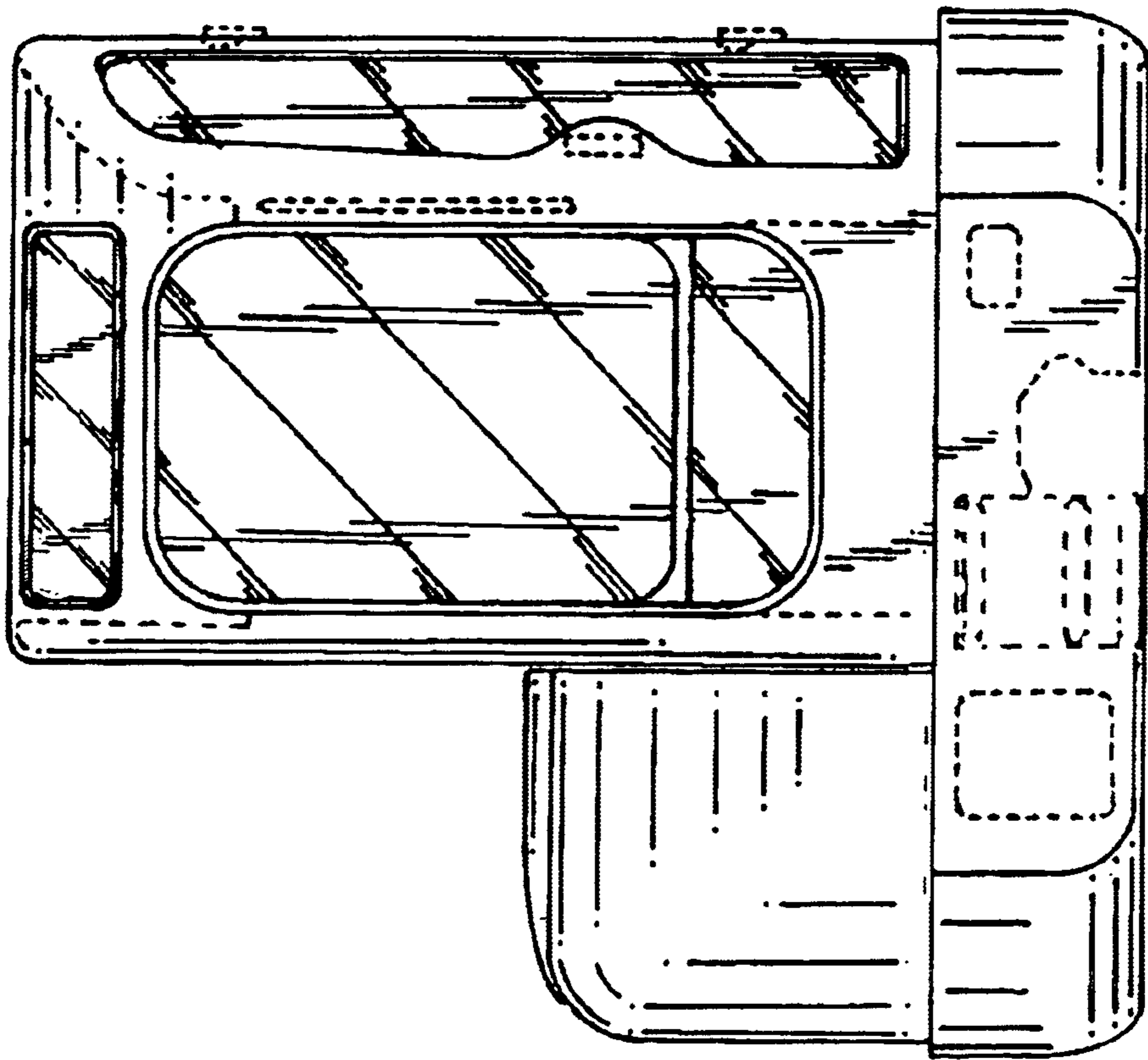
*Fig. 2*



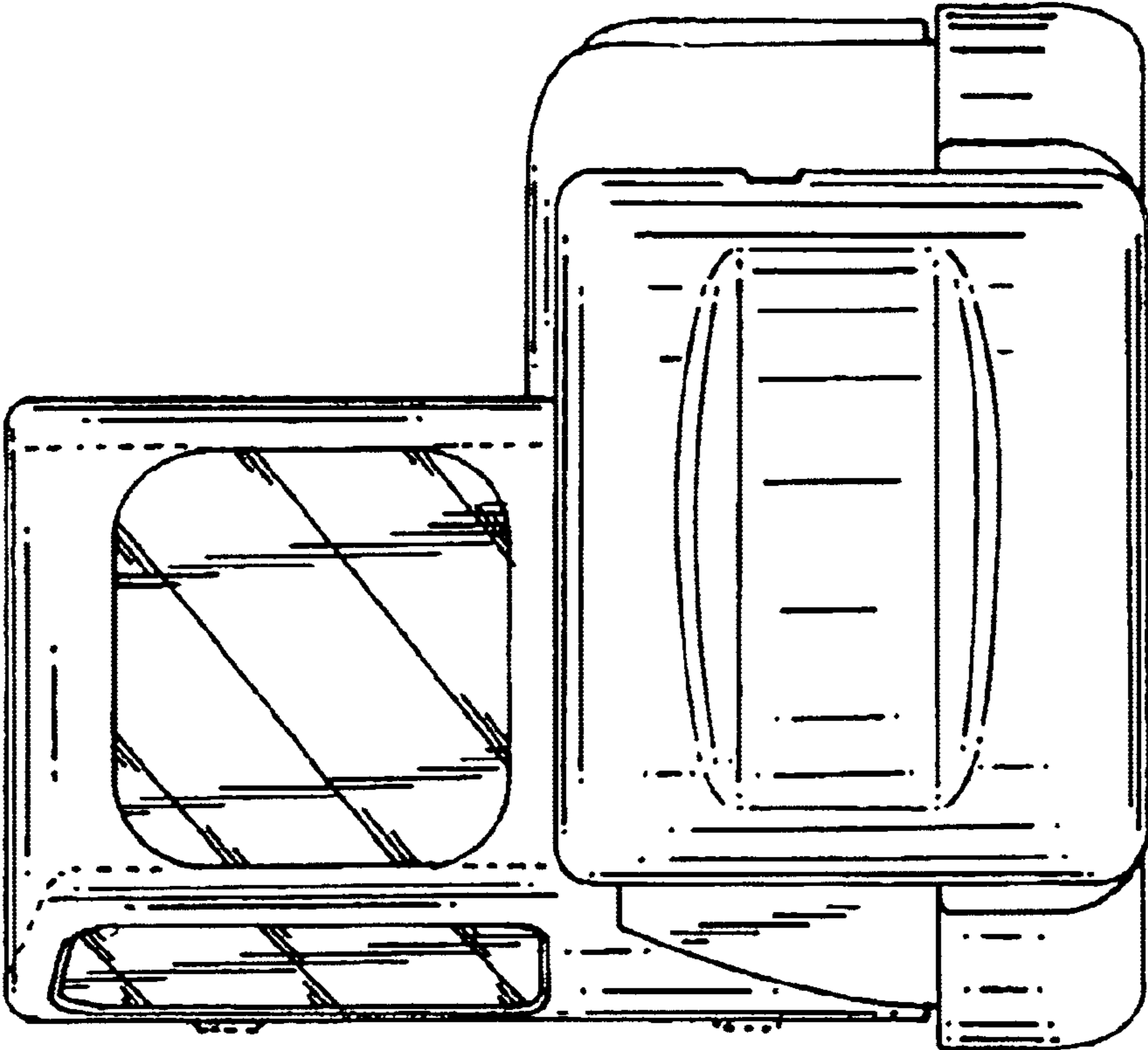
*Fig. 3*

*Fig. 4*





*Fig. 5*



*Fig. 6*

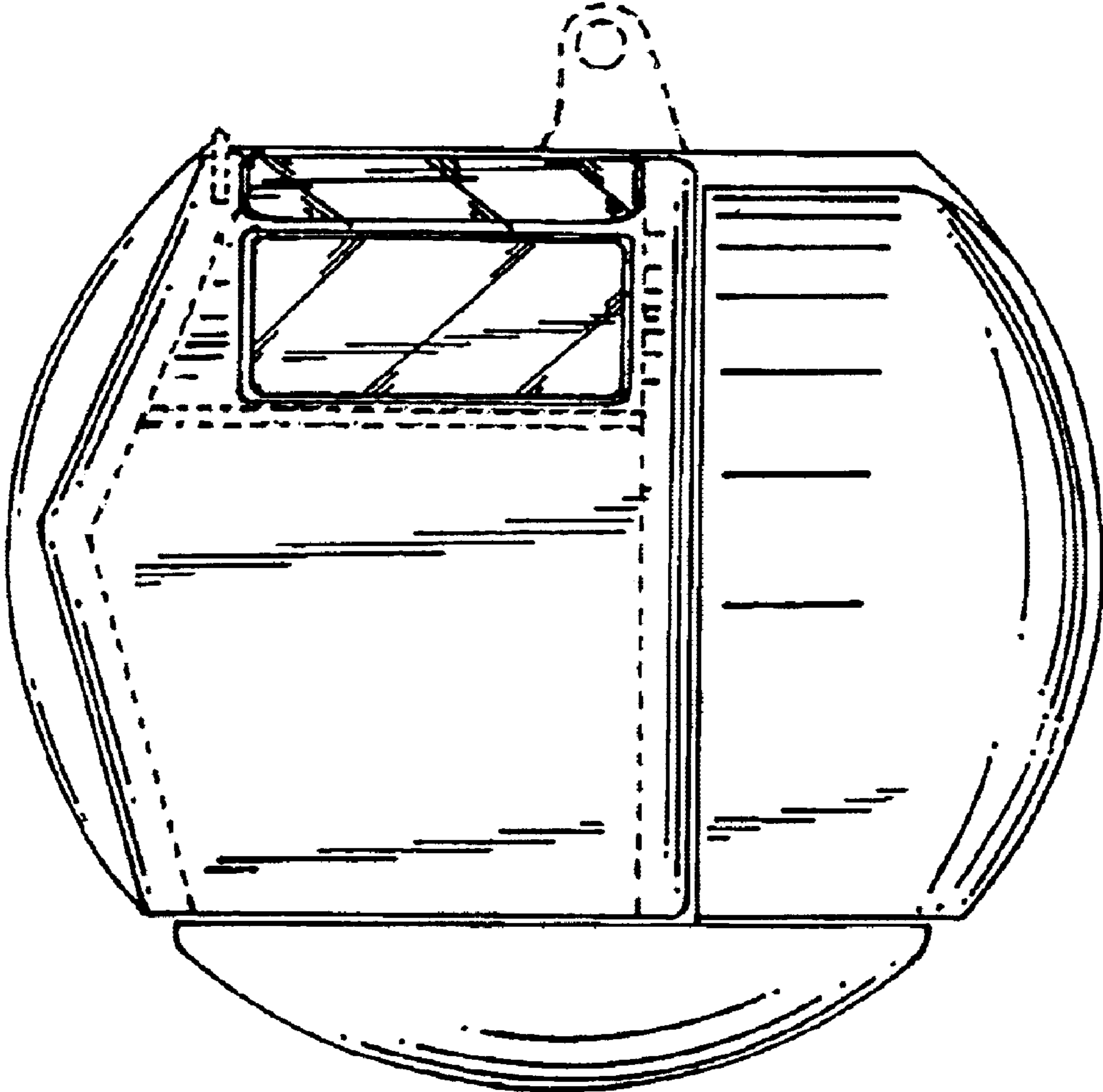
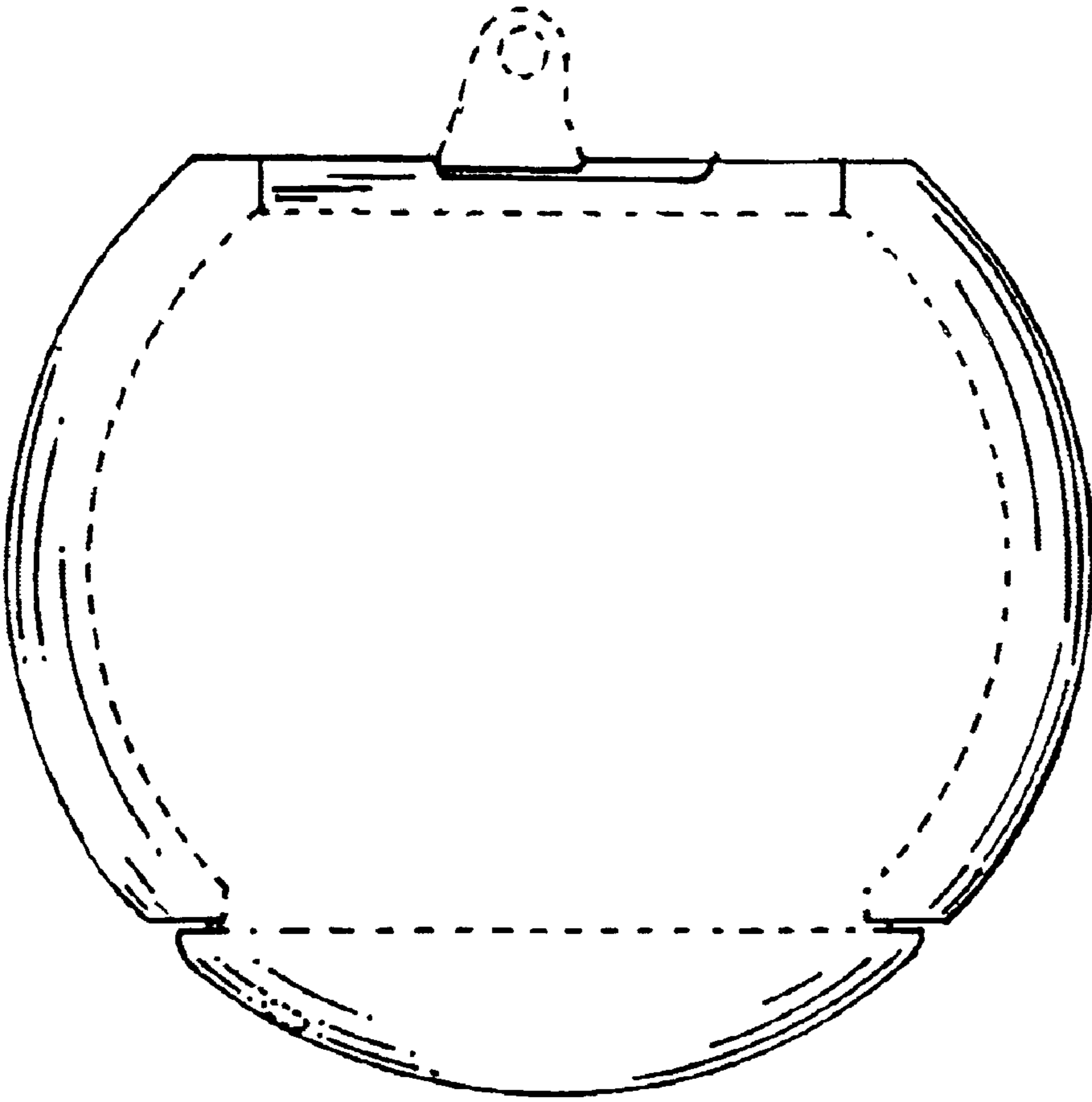


Fig. 7





*Fig. 8*

UNITED STATES PATENT AND TRADEMARK OFFICE  
**CERTIFICATE OF CORRECTION**

PATENT NO. : Des. 494,986 S  
DATED : August 24, 2004  
INVENTOR(S) : Thomas J. Tokach et al.

Page 1 of 1

It is certified that error appears in the above-identified patent and that said Letters Patent is hereby corrected as shown below:

Title page.

Item [73], Assignee, delete "**Clark Equipment Company**, Woodcliff, New Jersey (US)" and insert -- **Clark Equipment Company**, Woodcliff Lake, New Jersey (US) --.


Item [57], **CLAIM**, delete "cab exterior, as shown" and insert -- cab exterior as shown --.

**DESCRIPTION,**

FIG. 7, delete "view; and," and insert -- view; and --

Signed and Sealed this

Nineteenth Day of July, 2005

A handwritten signature in black ink on a dotted background. The signature reads "Jon W. Dudas" in a cursive style.

JON W. DUDAS

*Director of the United States Patent and Trademark Office*