

US00D494923S1

(12) **United States Design Patent**
Moler

(10) **Patent No.:** **US D494,923 S**

(45) **Date of Patent:** **** Aug. 24, 2004**

(54) **INTEGRAL FORCE TRANSFER MEMBER**

(75) **Inventor:** **Jeff Moler**, Sarasota, FL (US)

(73) **Assignee:** **Viking Technologies, L.C.**, Sarasota, FL (US)

(**) **Term:** **14 Years**

(21) **Appl. No.:** **29/162,686**

(22) **Filed:** **Jun. 19, 2002**

(51) **LOC (7) Cl.** **13-02**

(52) **U.S. Cl.** **D13/101**

(58) **Field of Search** D13/101, 118,
D13/152, 158, 173, 174; D15/1-7; 137/599;
310/328, 330, 348; 361/600, 605, 616

(56) **References Cited**

U.S. PATENT DOCUMENTS

3,558,936 A	1/1971	Horan	
3,649,857 A	3/1972	Knappe	
4,435,666 A	3/1984	Fukui et al.	
4,445,065 A	* 4/1984	Albert	310/338
4,460,840 A	7/1984	Weiger et al.	
4,570,095 A	2/1986	Uchikawa	
4,647,808 A	3/1987	Shibuya	
4,675,568 A	6/1987	Uchikawa et al.	
4,703,215 A	10/1987	Asano	
4,736,131 A	4/1988	Fujimoto	
4,777,398 A	10/1988	Shibuya	
4,783,610 A	11/1988	Asano	
4,785,215 A	* 11/1988	Blech	310/329
4,874,978 A	10/1989	Sakaida et al.	
4,874,980 A	10/1989	Mine et al.	
4,929,859 A	5/1990	Suzuki et al.	
4,937,489 A	6/1990	Hattori et al.	
4,979,275 A	12/1990	Sakaida et al.	
5,028,834 A	7/1991	Sakaida et al.	
5,059,850 A	* 10/1991	Yoshimura et al.	310/328

5,191,252 A	3/1993	Sano	
RE34,823 E	1/1995	Sakaida et al.	
5,410,206 A	4/1995	Luecke et al.	
5,479,064 A	12/1995	Sano	
5,712,524 A	1/1998	Suga	
5,881,767 A	3/1999	Loser	
6,025,671 A	2/2000	Boecking	
D430,116 S	* 8/2000	Huang	D13/184
6,131,879 A	10/2000	Kluge et al.	
6,250,158 B1	* 6/2001	Stewart	73/504.14
6,404,108 B1	* 6/2002	Yachi et al.	310/330
6,619,122 B1	* 9/2003	Nozoe	73/504.16

* cited by examiner

Primary Examiner—Philip S. Hyder

Assistant Examiner—Daniel Bui

(74) *Attorney, Agent, or Firm*—Young & Basile, P.C.

(57) **CLAIM**

The ornamental design for an integral force transfer member, as shown and described.

DESCRIPTION

FIG. 1 is a perspective view of an integral force transfer member, showing my design;

FIG. 2 is a front elevation view thereof. It is understood that the rear elevation view being a mirror image of FIG. 2;

FIG. 3 is a bottom plan view thereof;

FIG. 4 is a top plan view thereof;

FIG. 5 is a left side elevation view thereof; and,

FIG. 6 is a right side elevation view thereof.

The broken line showing of the environment is for illustrative purposes only and forms no part of the claimed design. The present design is directed to an ornamental design for the integral force transfer member for moving associated elements of a clamp, valve, or motor, with respect to one another using a piezoelectric actuator.

1 Claim, 2 Drawing Sheets

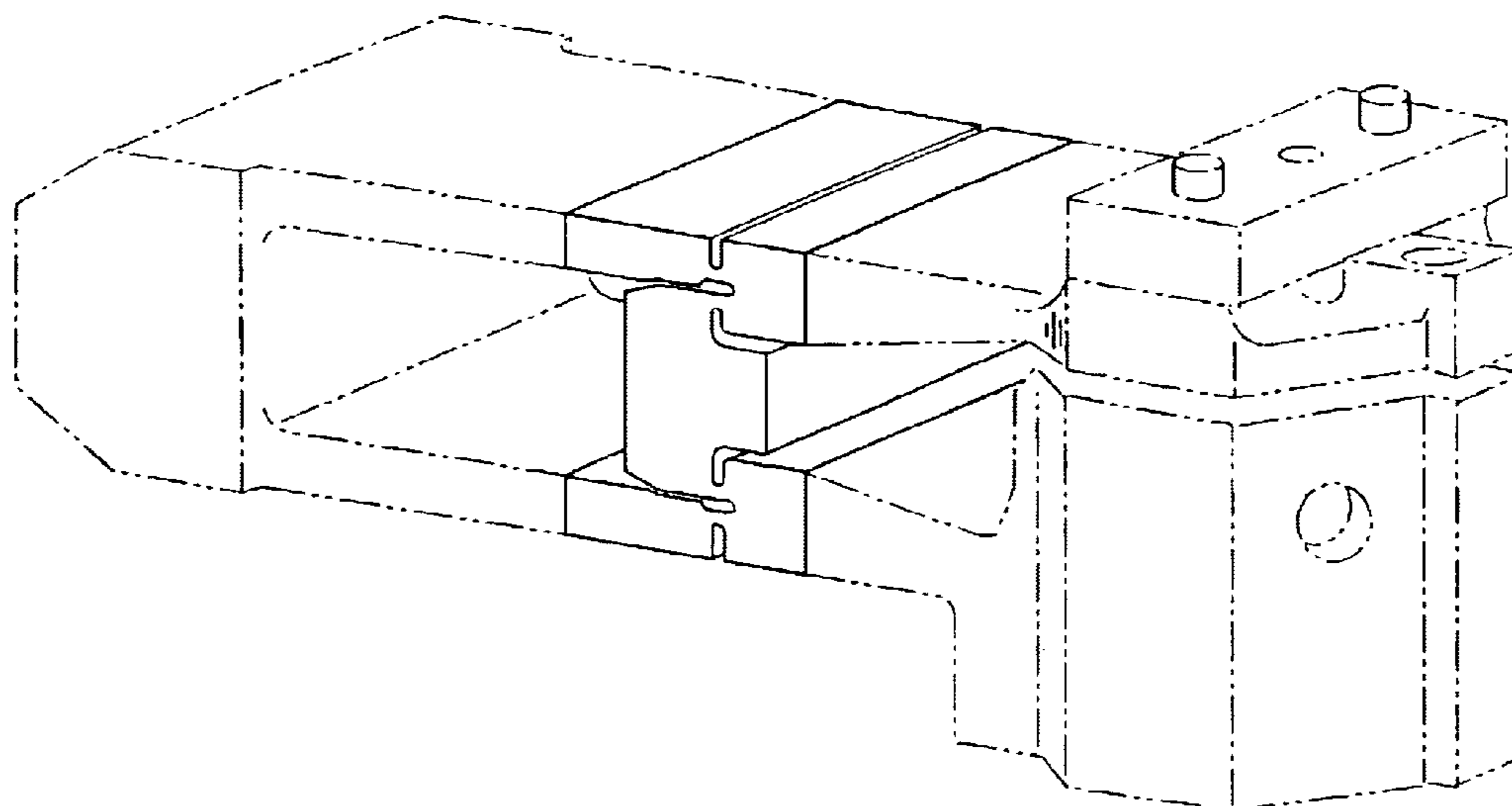

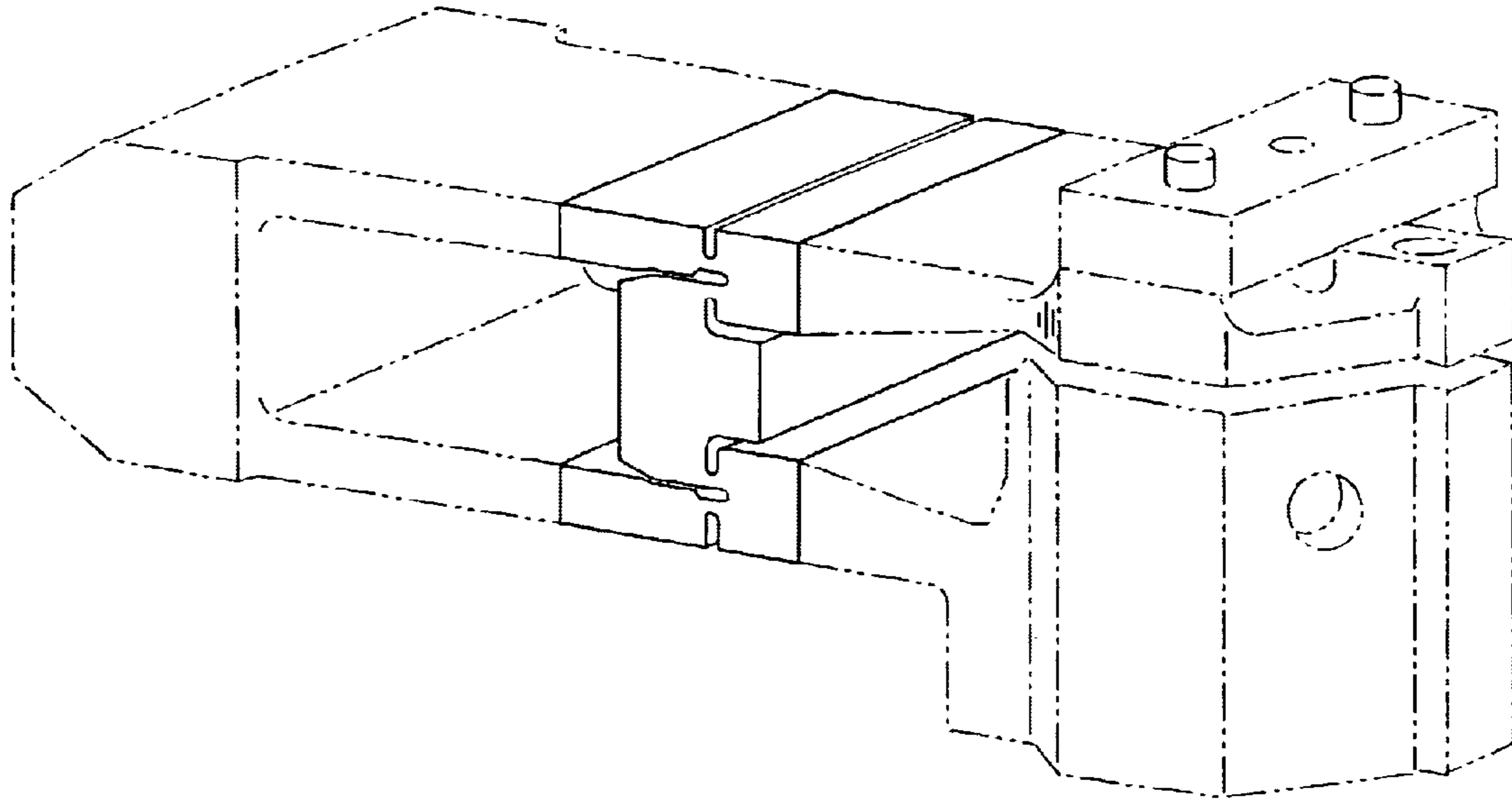

FIG - 1

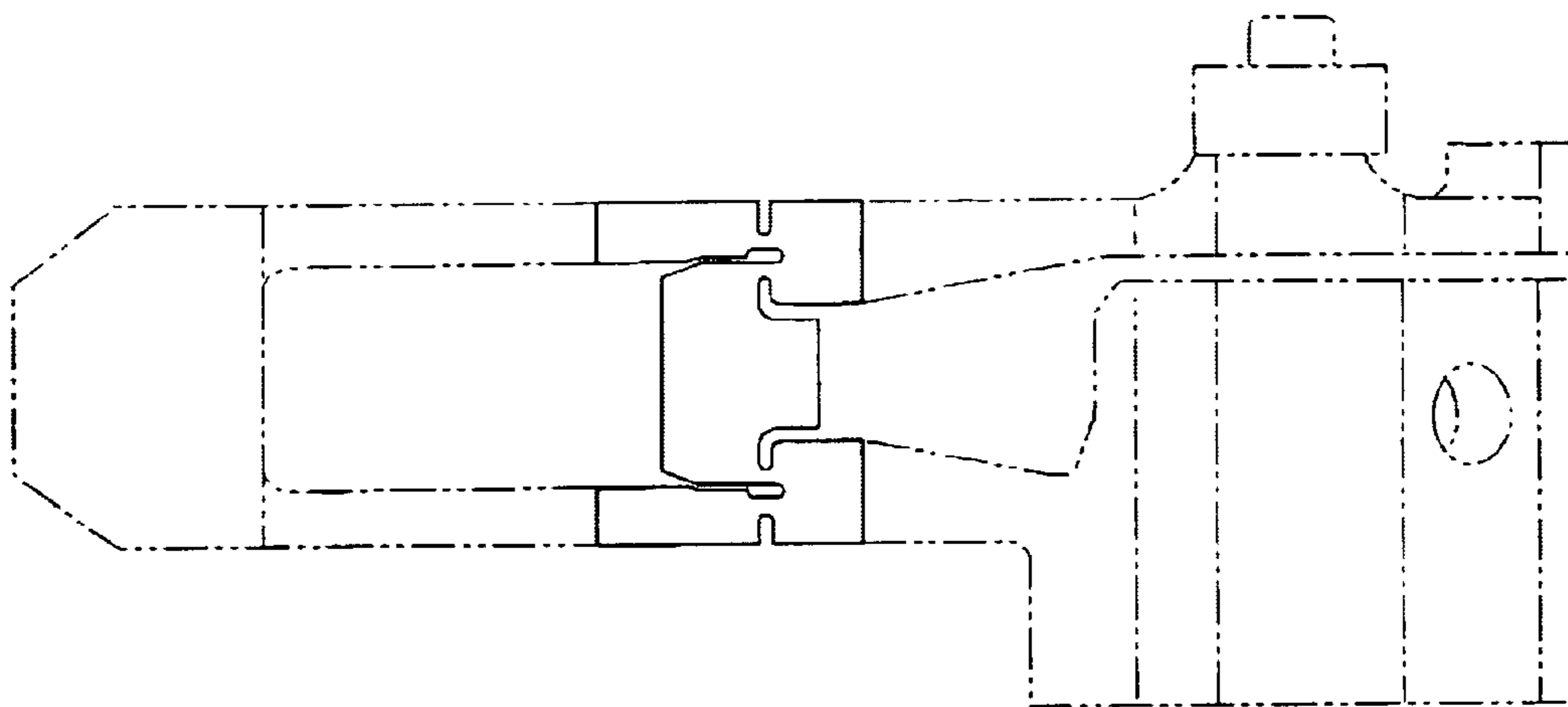

FIG - 2

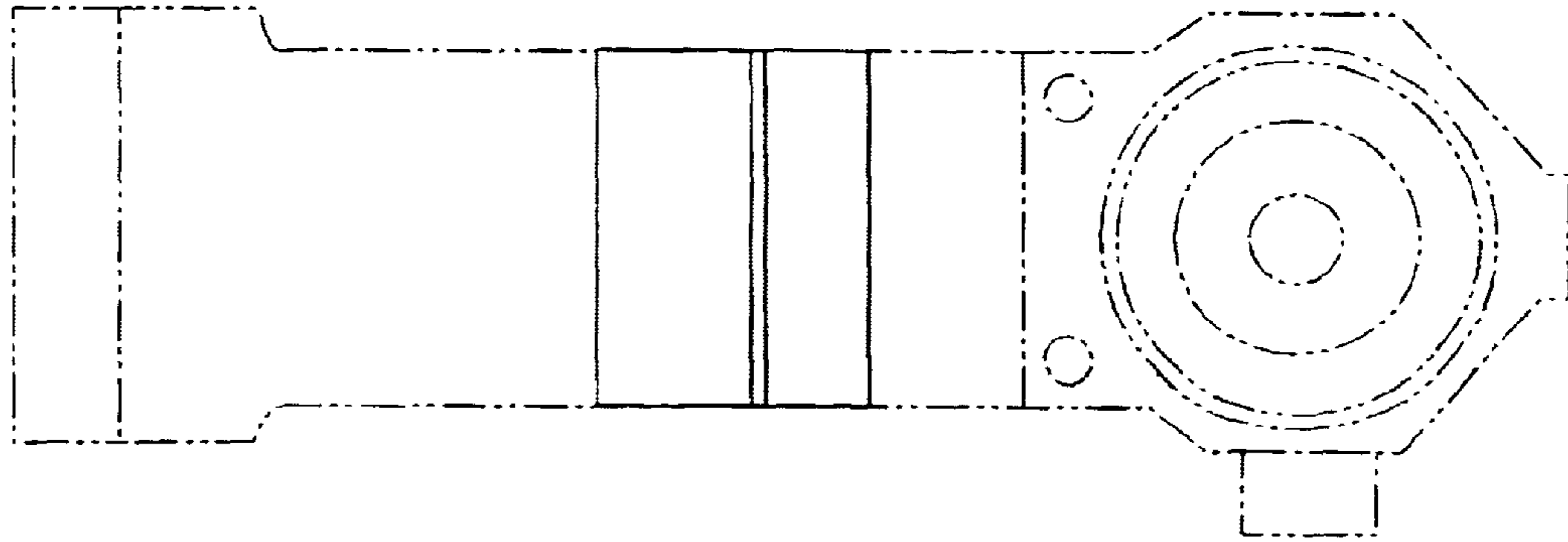

FIG - 3

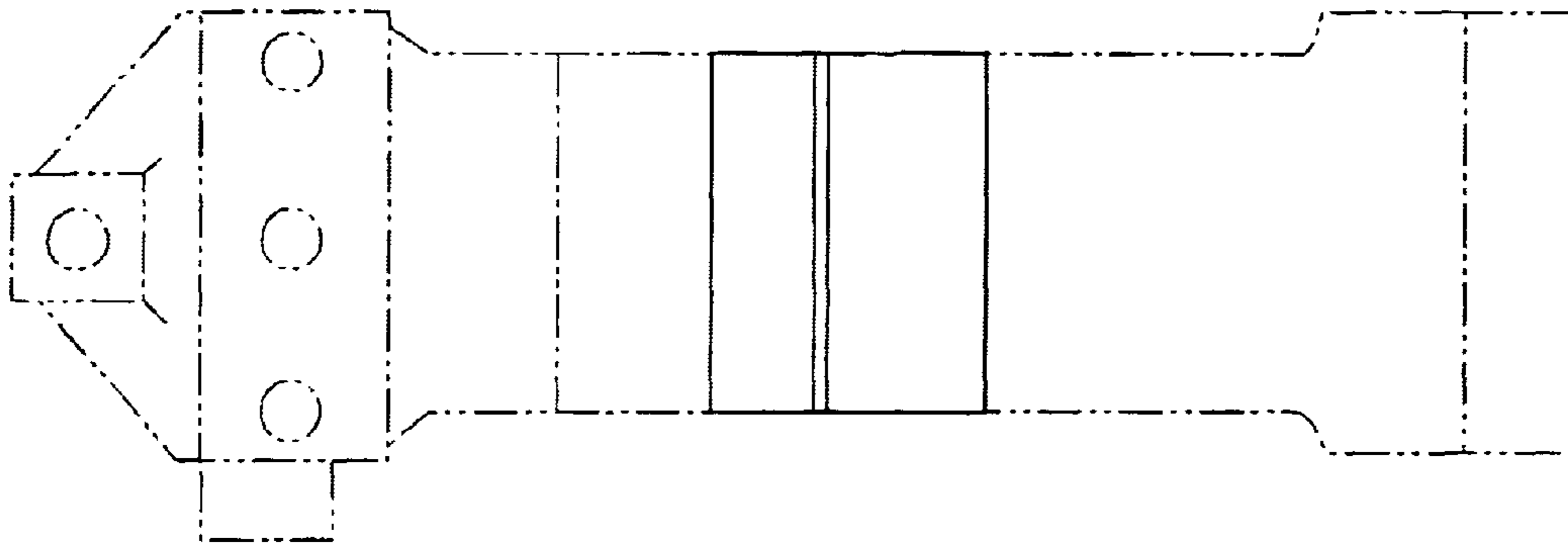

FIG - 4

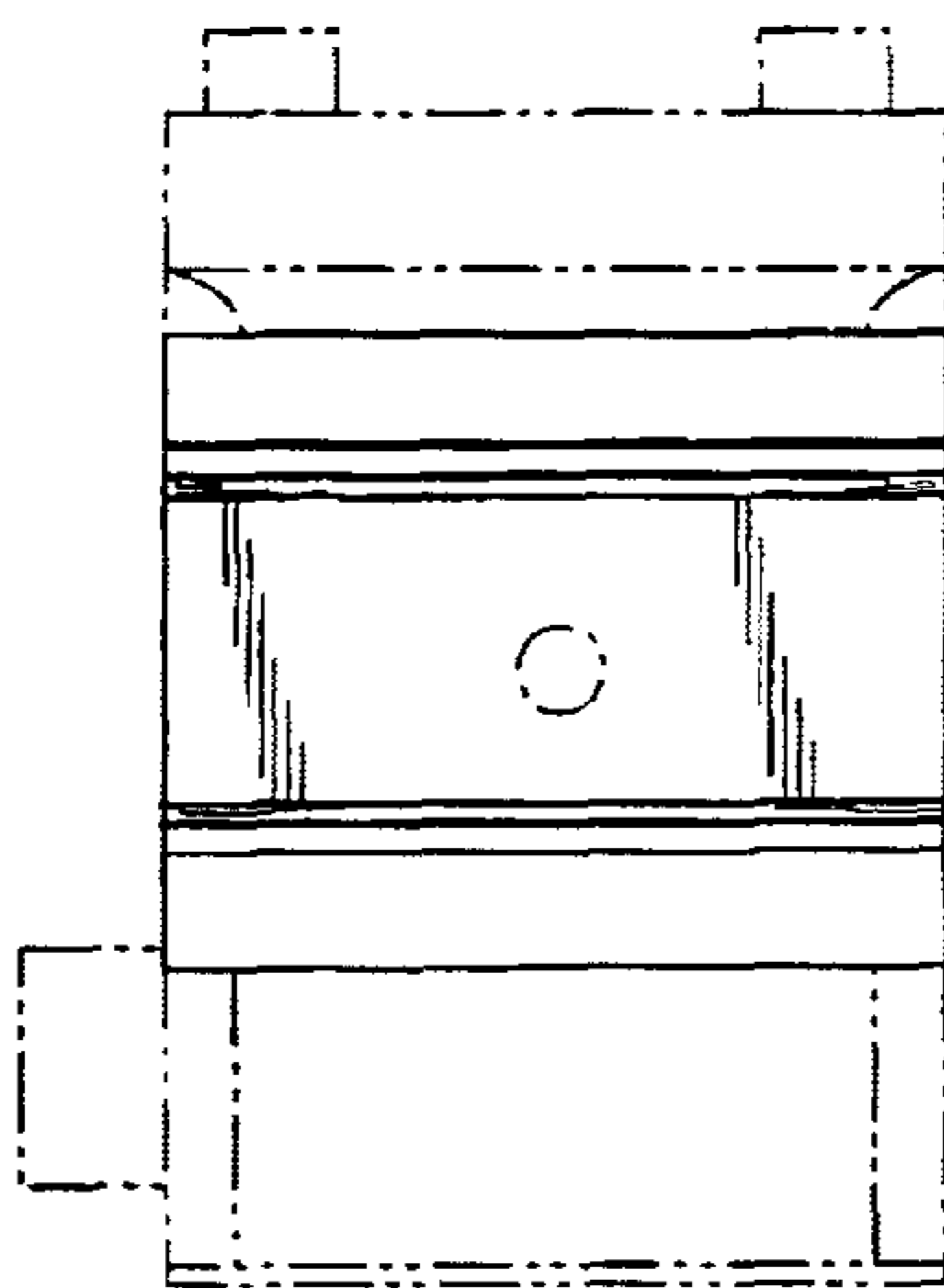

FIG - 5

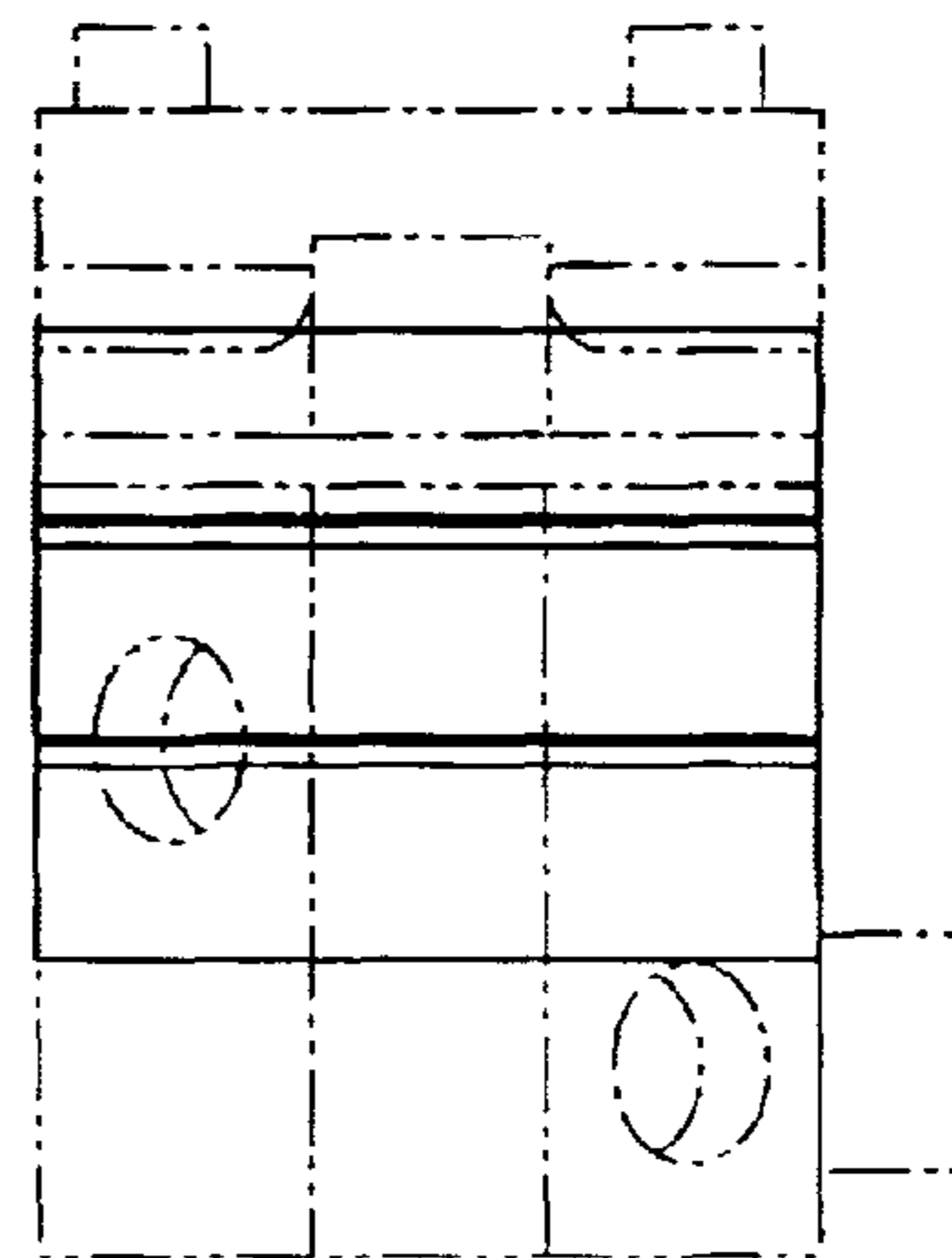

FIG - 6