

US00D494919S1

(12) **United States Design Patent**
Davis et al.

(10) **Patent No.:** **US D494,919 S**
(45) **Date of Patent:** **** Aug. 24, 2004**

(54) **VEHICLE TIE-DOWN UNIT**

(76) Inventors: **Gail M. Davis**, 5916 Tipton Road
N.W., Calgary, Alberta (CA), T2K 3L2;
Bradley R. Davis, 5916 Tipton Road
N.W., Calgary, Alberta (CA), T2K 3L2

(**) **Term:** **14 Years**

(21) **Appl. No.:** **29/174,955**

(22) **Filed:** **Jan. 29, 2003**

(51) **LOC (7) Cl.** **12-06**

(52) **U.S. Cl.** **D12/223**

(58) **Field of Search** D12/223, 400;
410/9-11, 20, 21, 30-33, 42-50, 91-121,
127, 129, 140, 152-154; 224/42.21, 42.28,
512, 513, 517

(56) **References Cited**

U.S. PATENT DOCUMENTS

4,008,669	A	*	2/1977	Sumrell	410/47
4,217,831	A		8/1980	Koliba et al.		
4,227,633	A		10/1980	Sellberg		
4,786,223	A		11/1988	Crissy et al.		
4,960,353	A	*	10/1990	Thorndyke	410/20
5,584,622	A	*	12/1996	Dickerson, Sr.	410/21
5,586,849	A	*	12/1996	Kissel et al.	410/10
5,658,106	A	*	8/1997	Dickerson, Sr.	410/20

5,888,039	A	*	3/1999	Cooley	410/50
5,941,665	A	*	8/1999	Dahlin	410/20
6,109,844	A	*	8/2000	Nadherny et al.	410/34
6,139,231	A	*	10/2000	Kissel	410/20
6,287,060	B1	*	9/2001	Girardin	410/7
6,422,794	B1	*	7/2002	Zhan et al.	410/100

* cited by examiner

Primary Examiner—Melody N. Brown

(74) *Attorney, Agent, or Firm*—Donald R. Schoonover

(57) **CLAIM**

The ornamental design for a vehicle tie-down unit, as shown and described.

DESCRIPTION

FIG. 1 is a perspective view of a vehicle tie-down unit showing our new design;
FIG. 2 is a side elevational view thereof;
FIG. 3 is an elevational view of the opposite side thereof;
FIG. 4 is an end elevational view thereof;
FIG. 5 is an elevational view of the opposite end thereof;
FIG. 6 is a top plan view thereof;
FIG. 7 is a bottom plan view thereof; and,
FIG. 8 is a reduced side elevation view showing the vehicle tie-down unit in use; the broken lines depict environmental structure for illustrative purposes only and form no part of the claimed design.

1 Claim, 5 Drawing Sheets

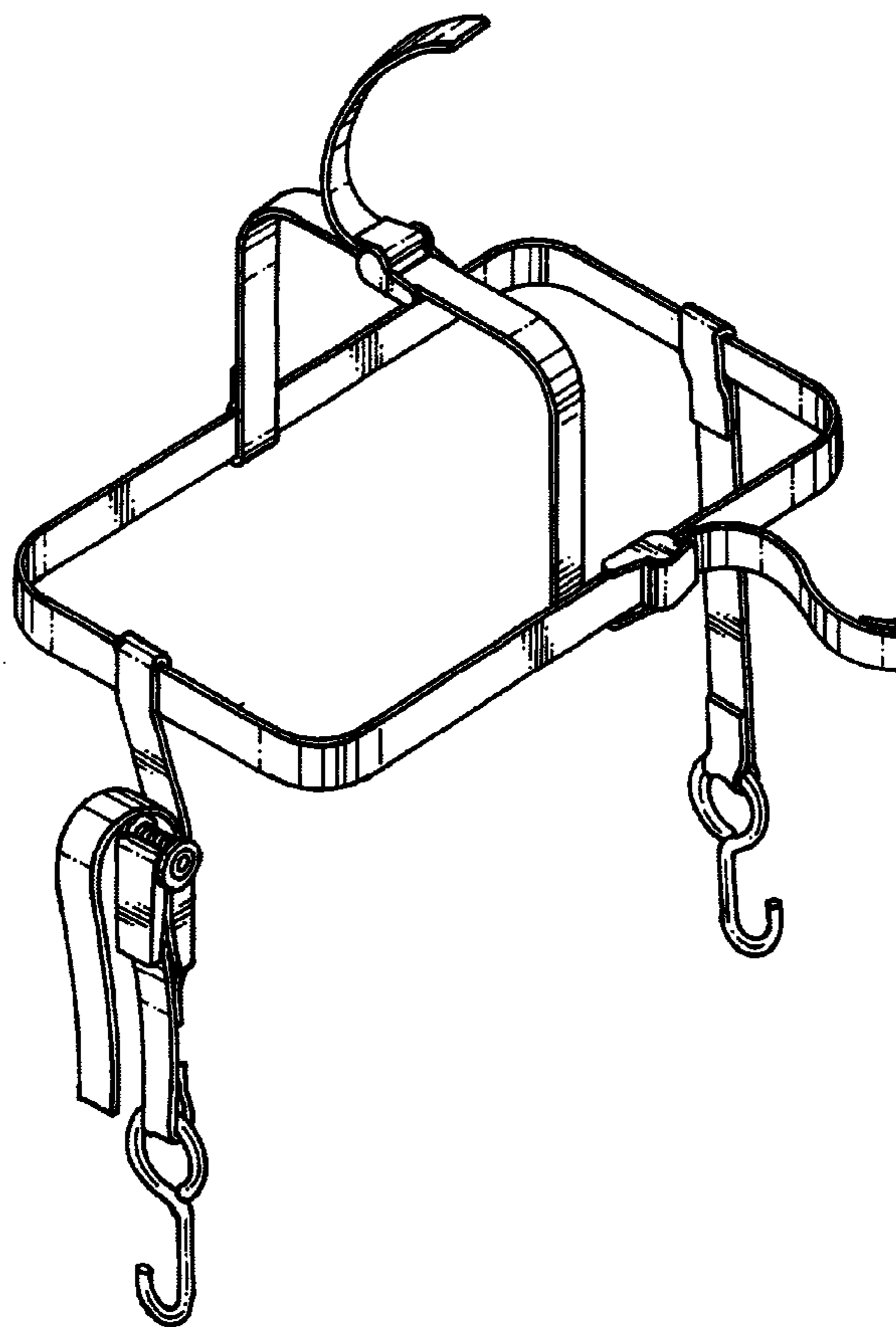

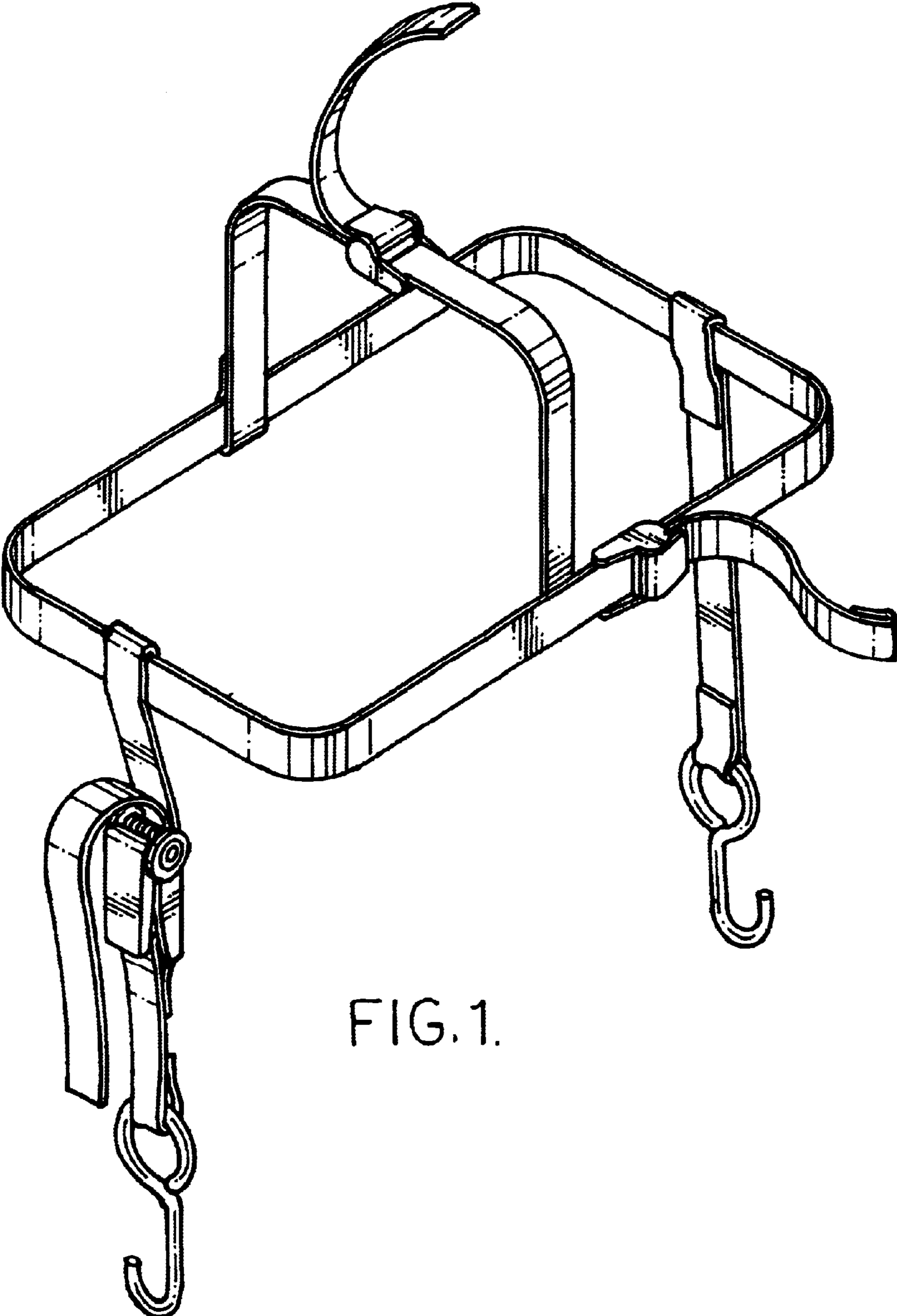
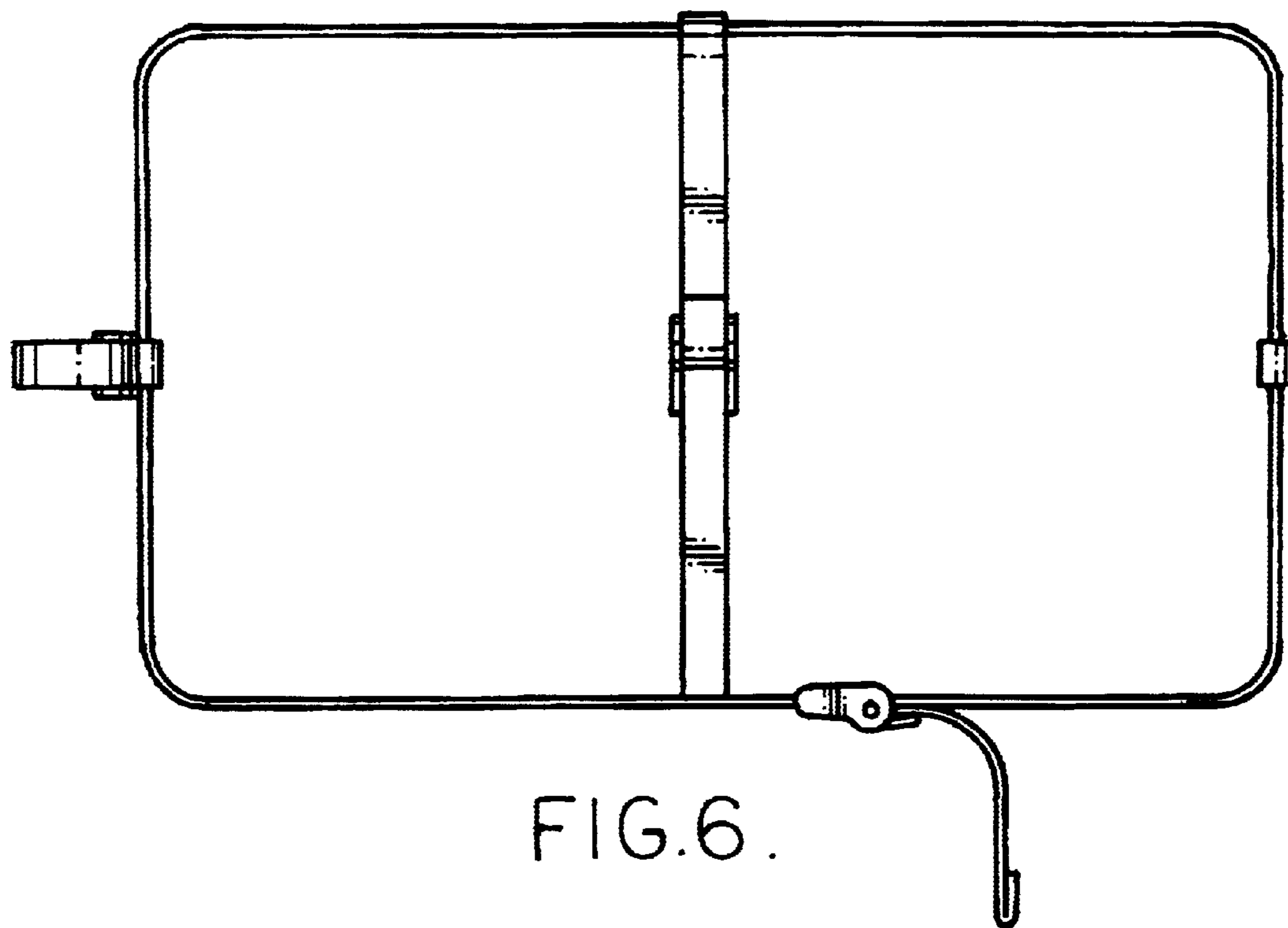
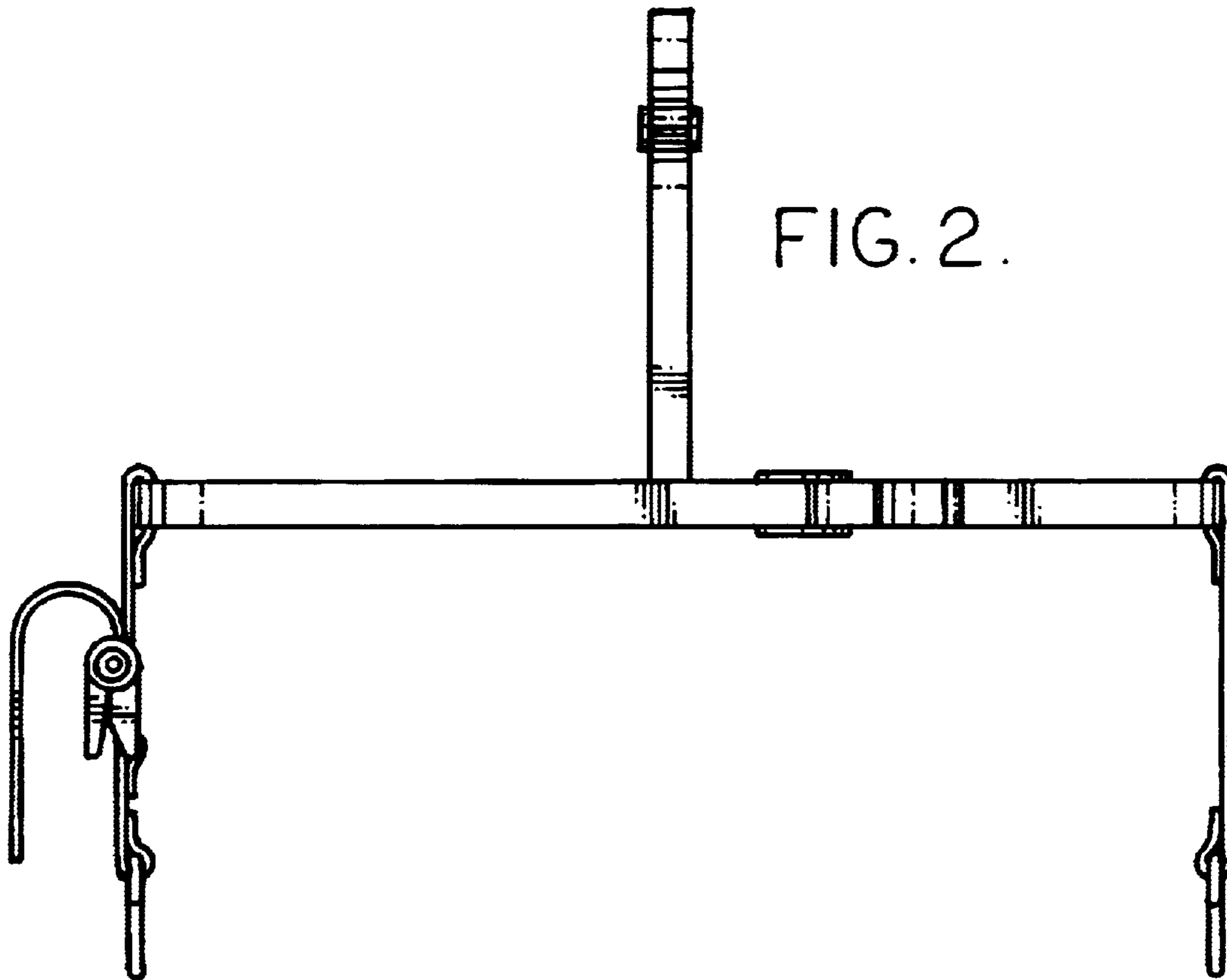
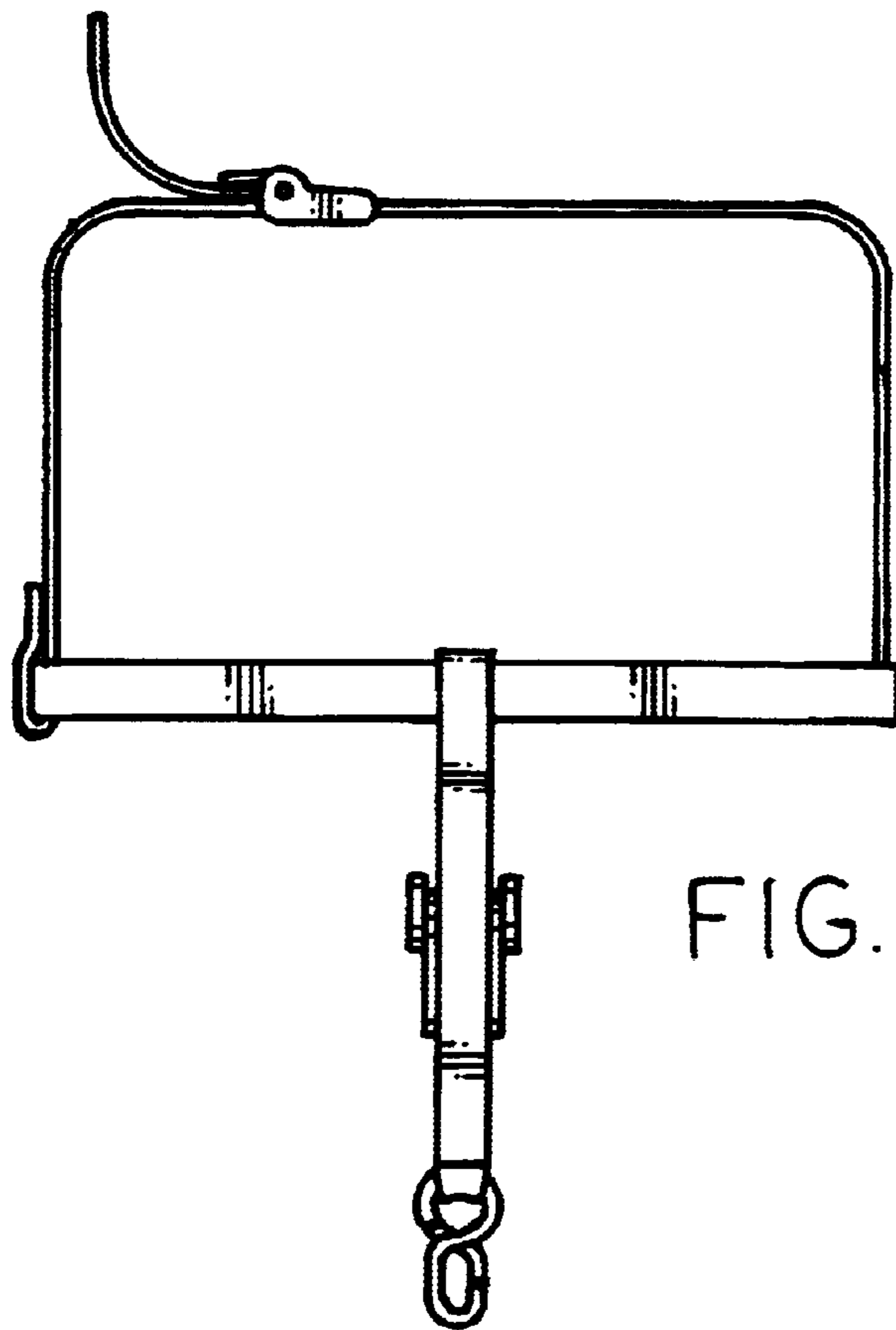
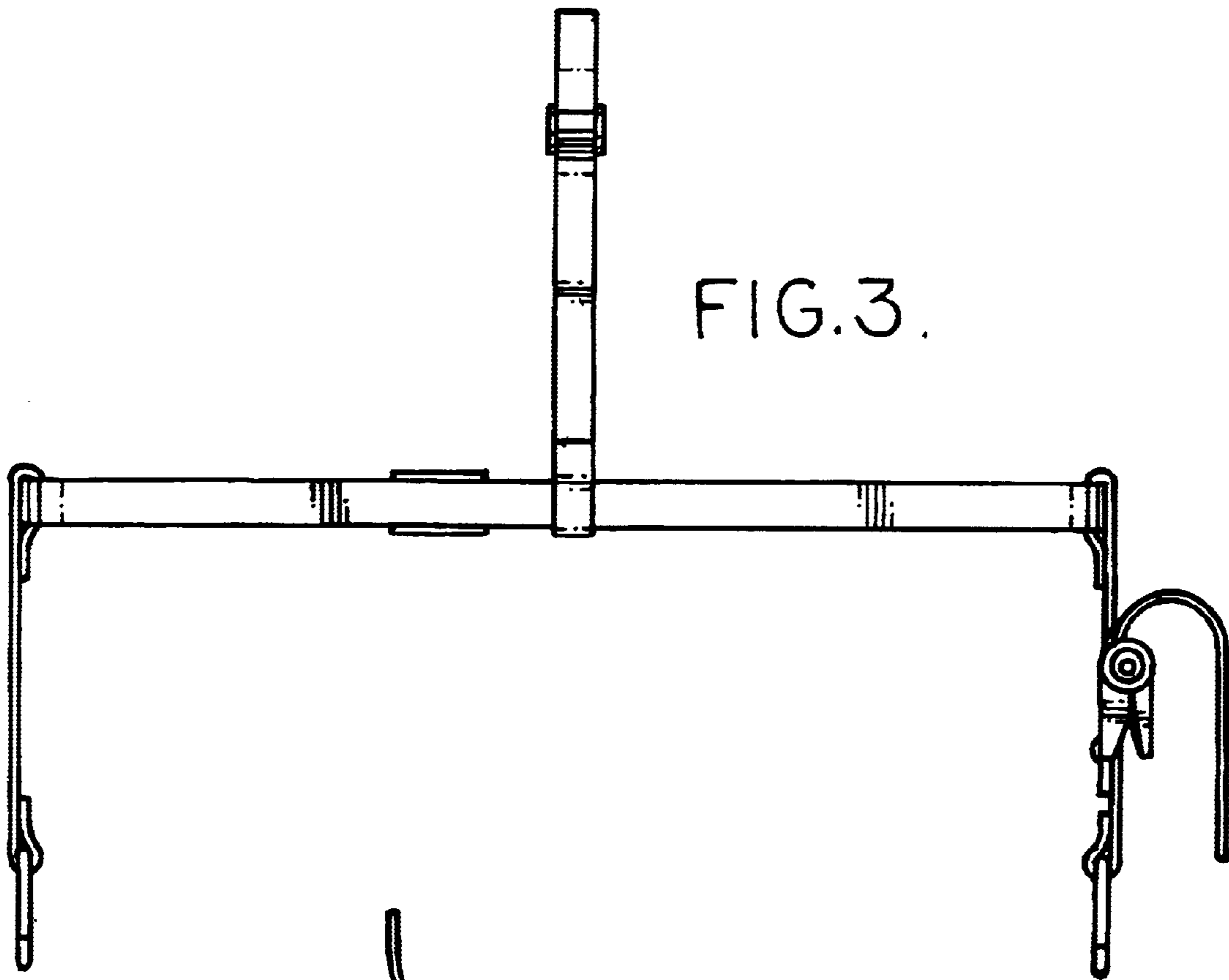

FIG. 1.





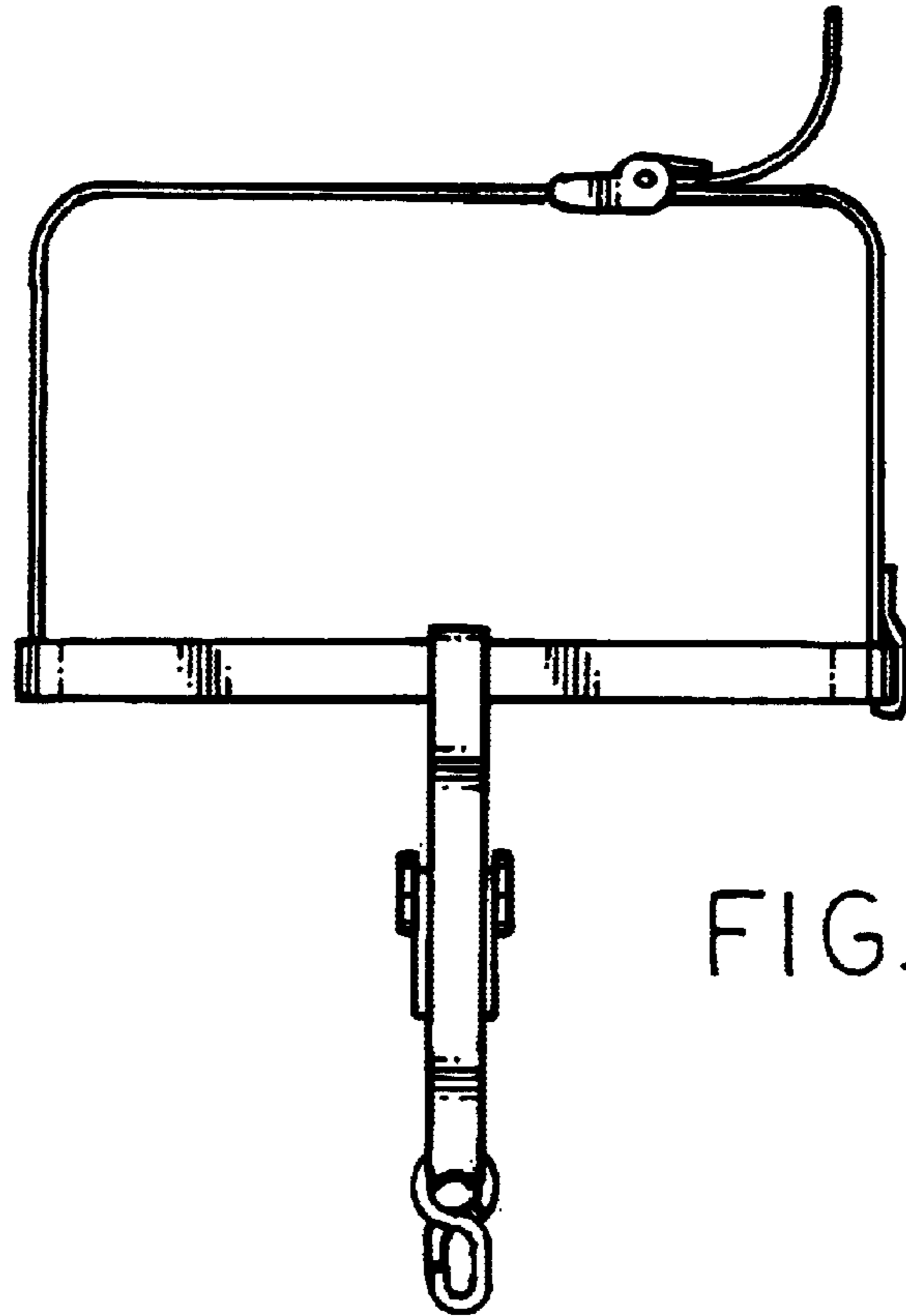

FIG. 5.

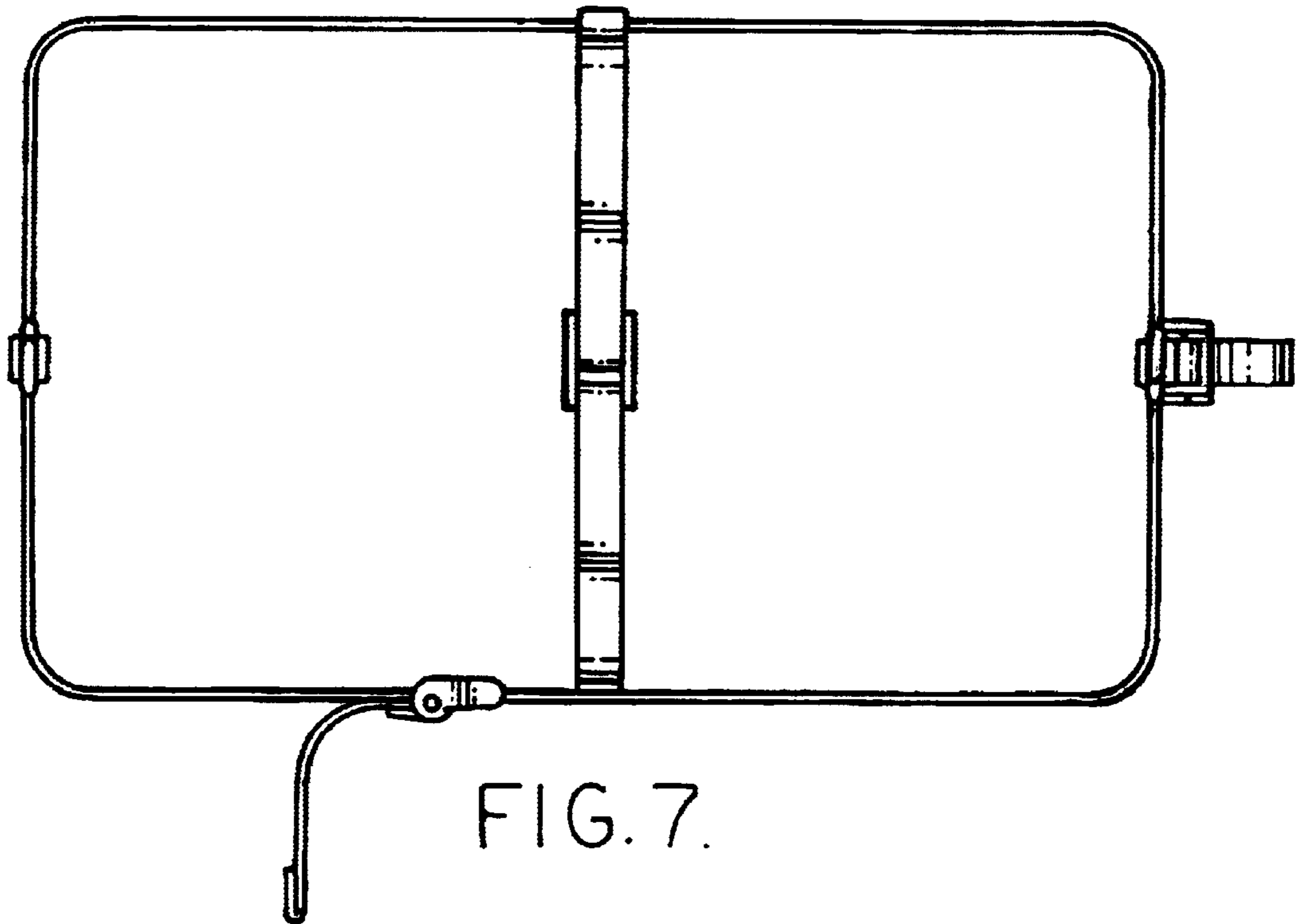

FIG. 7.

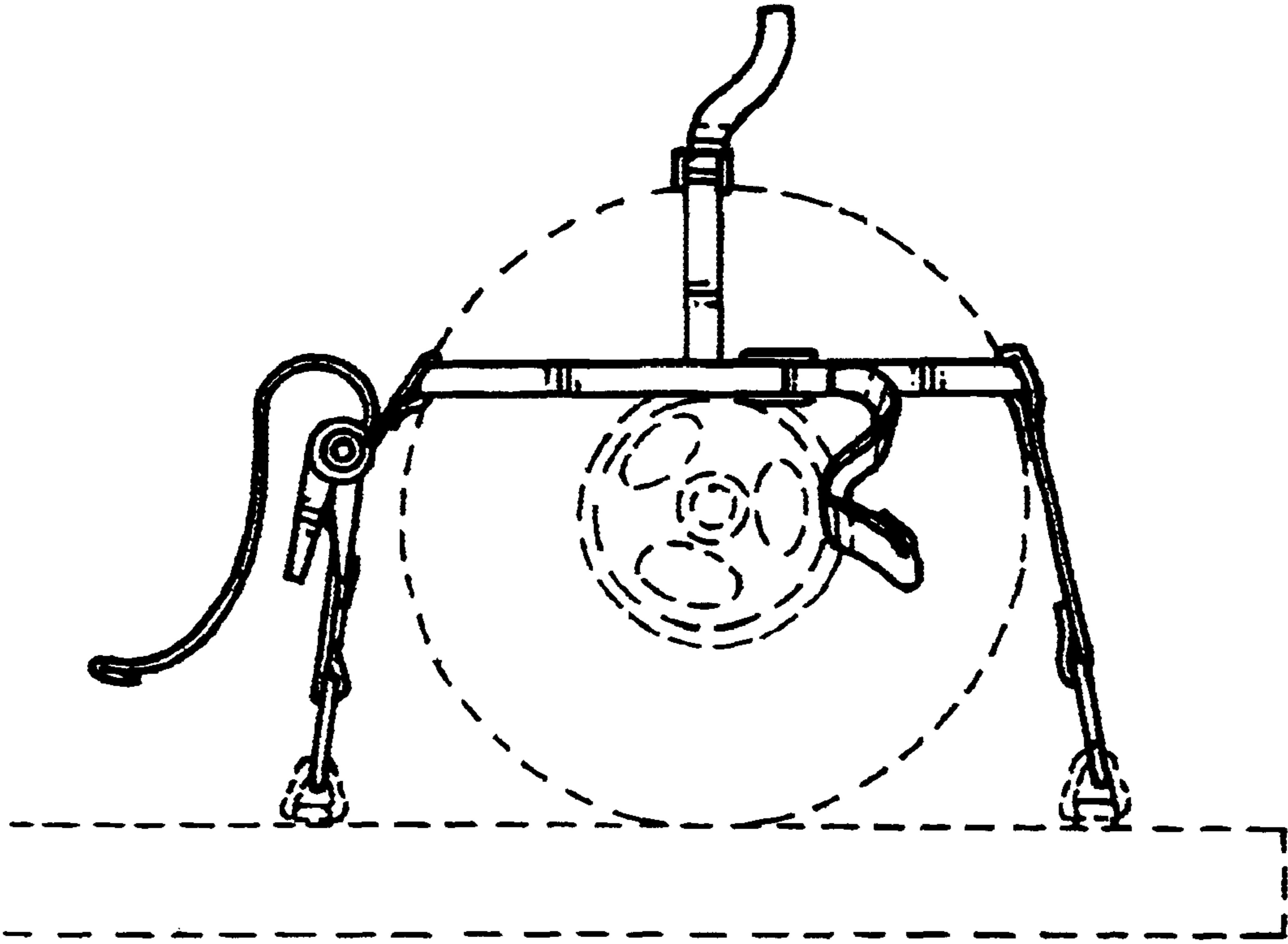

FIG.8.