



US00D494902S1

(12) **United States Design Patent**
Wen

(10) **Patent No.:** **US D494,902 S**

(45) **Date of Patent:** **** Aug. 24, 2004**

(54) **HYDRAULIC BRAKE**

Primary Examiner—Lisa Lichtenstein

(76) **Inventor:** **Chun Te Wen**, No. 1 Alley 16 Lane 40,
Jinn Te Road, Taichung (TW)

(57) **CLAIM**

The ornamental design for a hydraulic brake, as shown and described.

(**) **Term:** **14 Years**

(21) **Appl. No.:** **29/183,826**

DESCRIPTION

(22) **Filed:** **Jun. 16, 2003**

(51) **LOC (7) Cl.** **12-16**

(52) **U.S. Cl.** **D12/180**

(58) **Field of Search** D12/180; 188/71.1,
188/73.3, 73.45, 73.34, 73.35

FIG. 1 is a front-right-top perspective view of a hydraulic brake, showing my new design;
FIG. 2 is a front elevational view thereof;
FIG. 3 is a rear elevational view thereof.
FIG. 4 is a left side elevational view thereof;
FIG. 5 is a right side elevational view thereof;
FIG. 6 is a top plan view thereof; and,
FIG. 7 is a bottom plan view thereof.

(56) **References Cited**

U.S. PATENT DOCUMENTS

D392,234 S	*	3/1998	Wallace	D12/180
D439,873 S	*	4/2001	Terasawa	D12/180
D450,280 S	*	11/2001	Brumfield	D12/180
D462,040 S	*	8/2002	Ueno et al.	D12/180

The cross-hatching fragmentarily shown in FIGS. 4, 5 and 7 represents knurling, and is understood to extend uniformly throughout the areas represented.

* cited by examiner

1 Claim, 7 Drawing Sheets

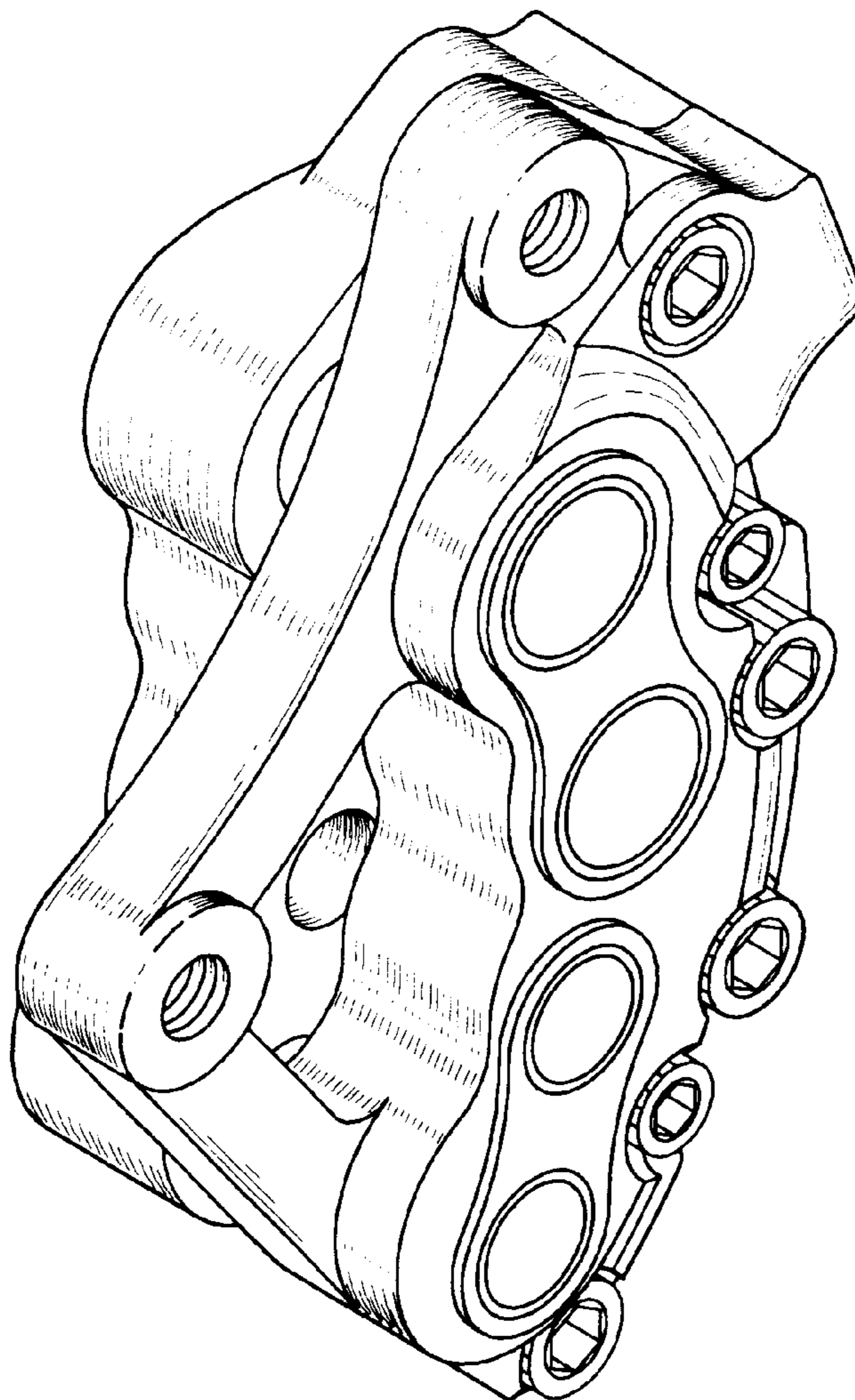

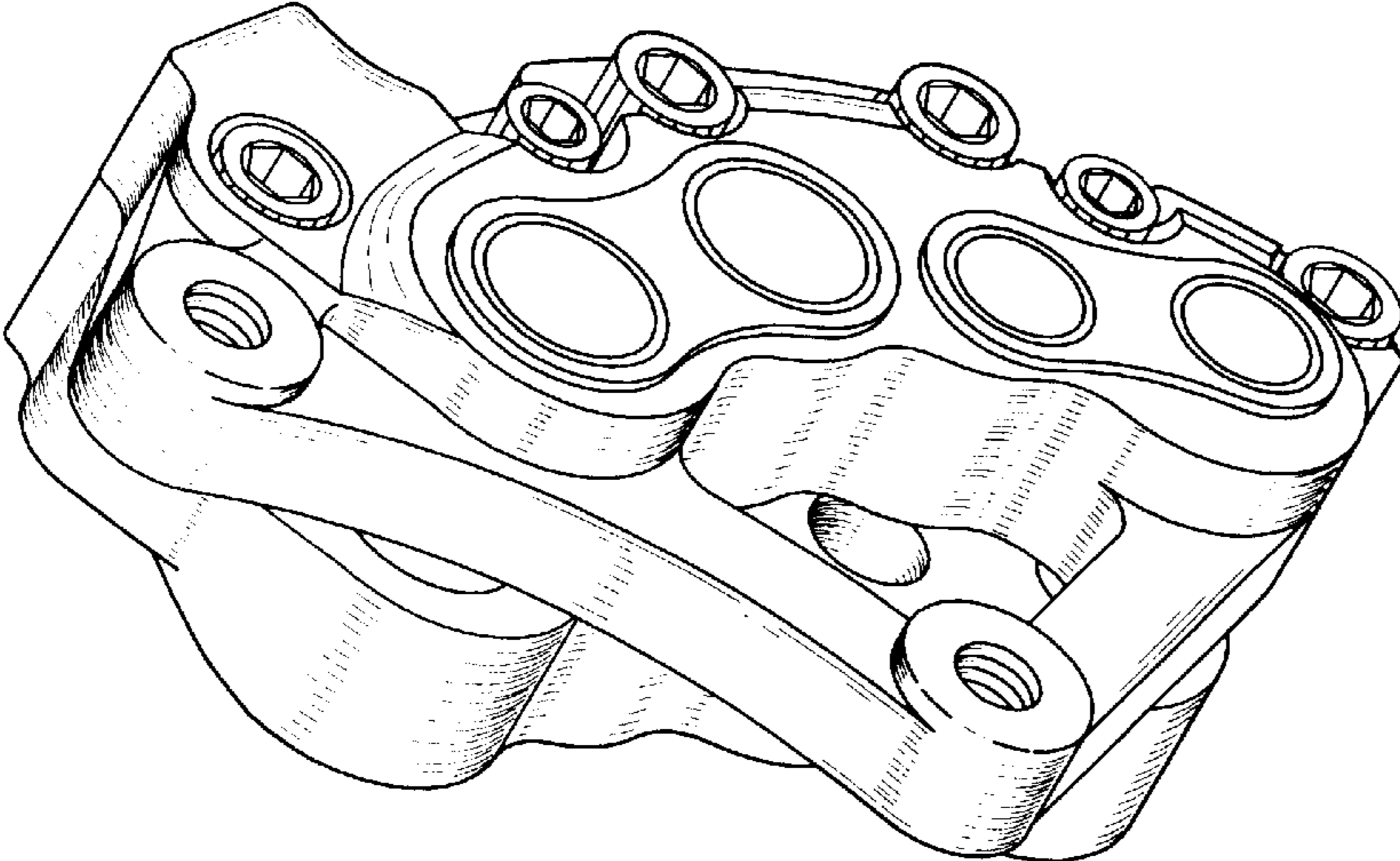

FIG.1

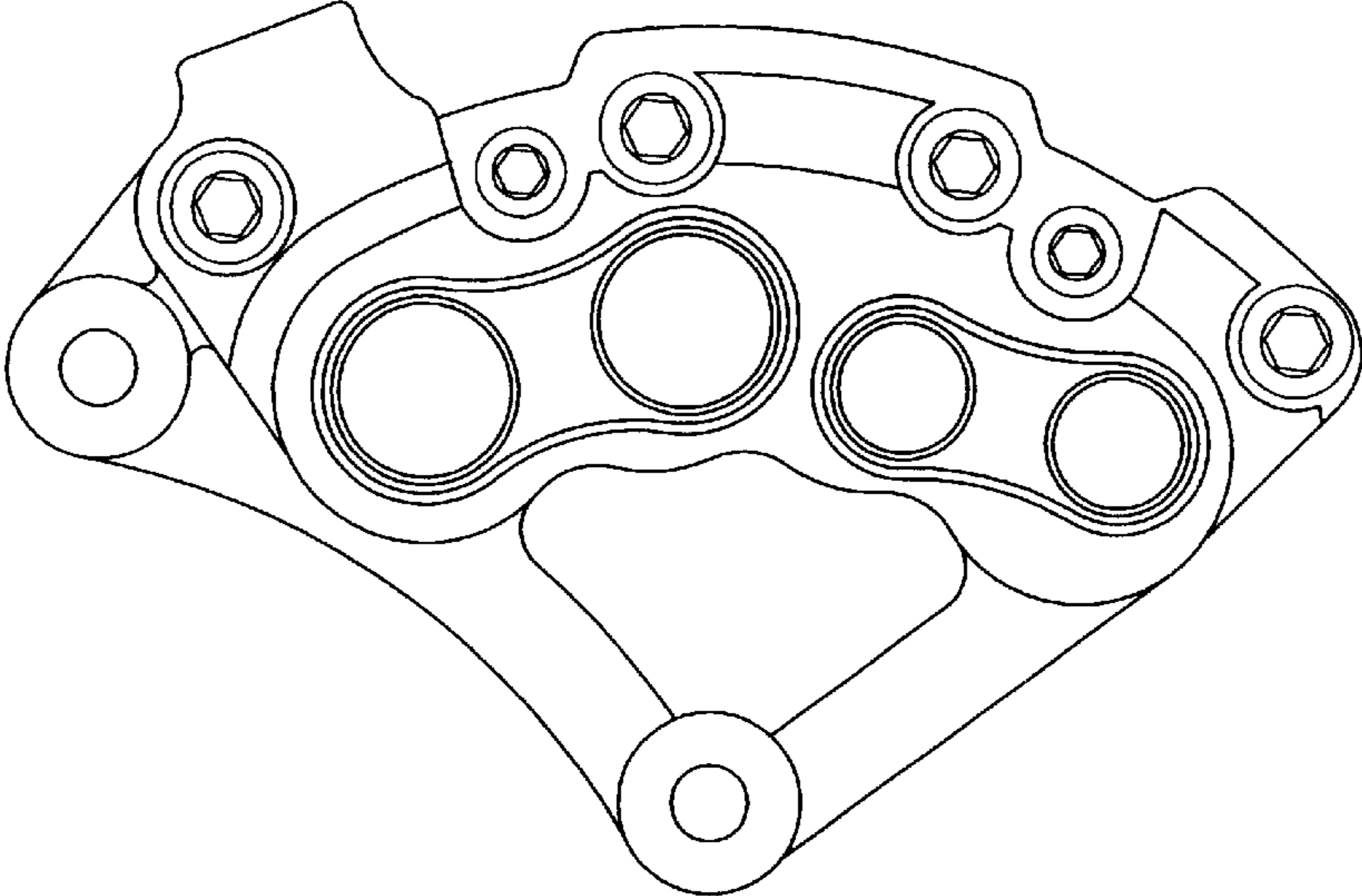

FIG.2

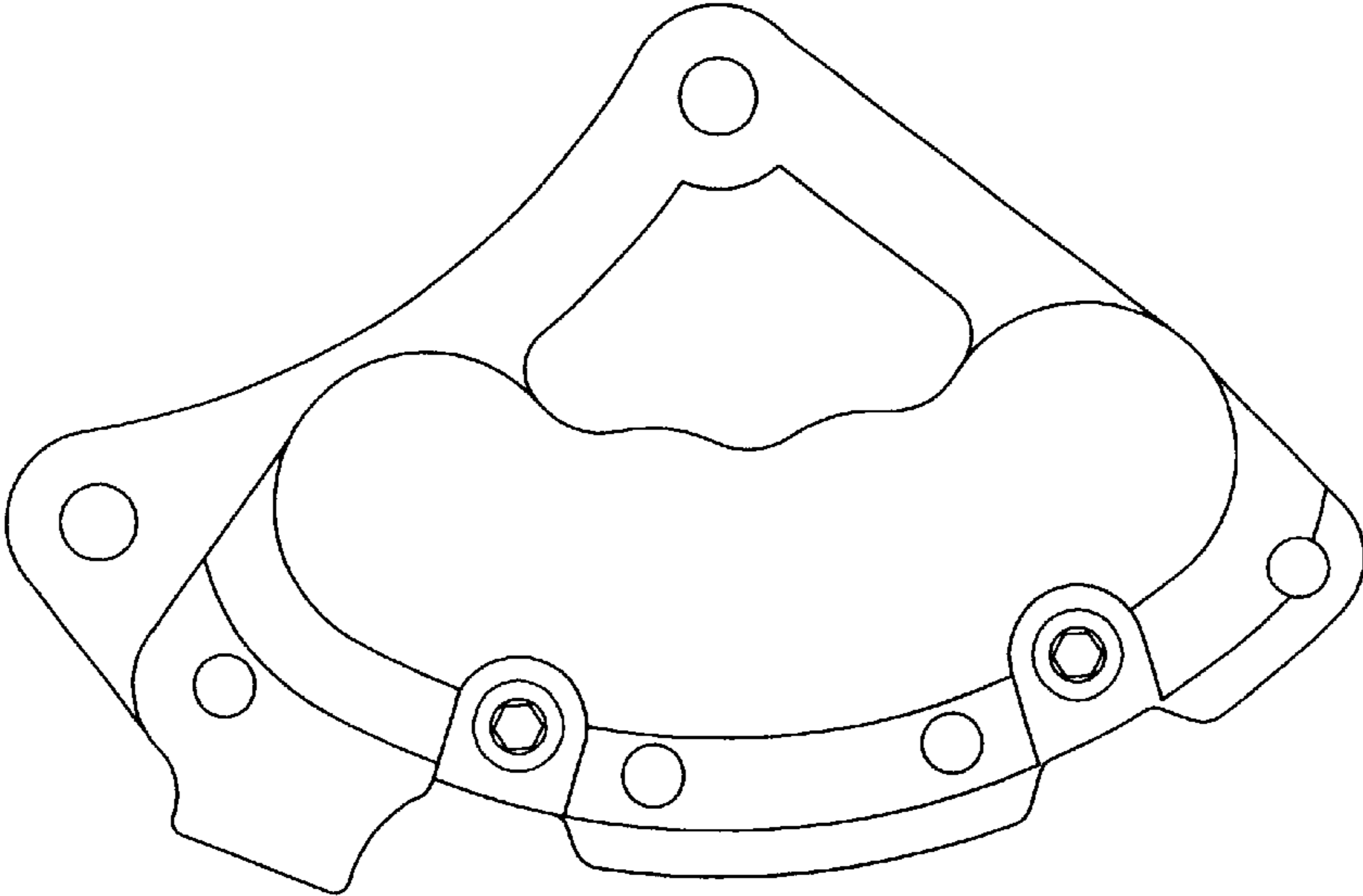

FIG.3

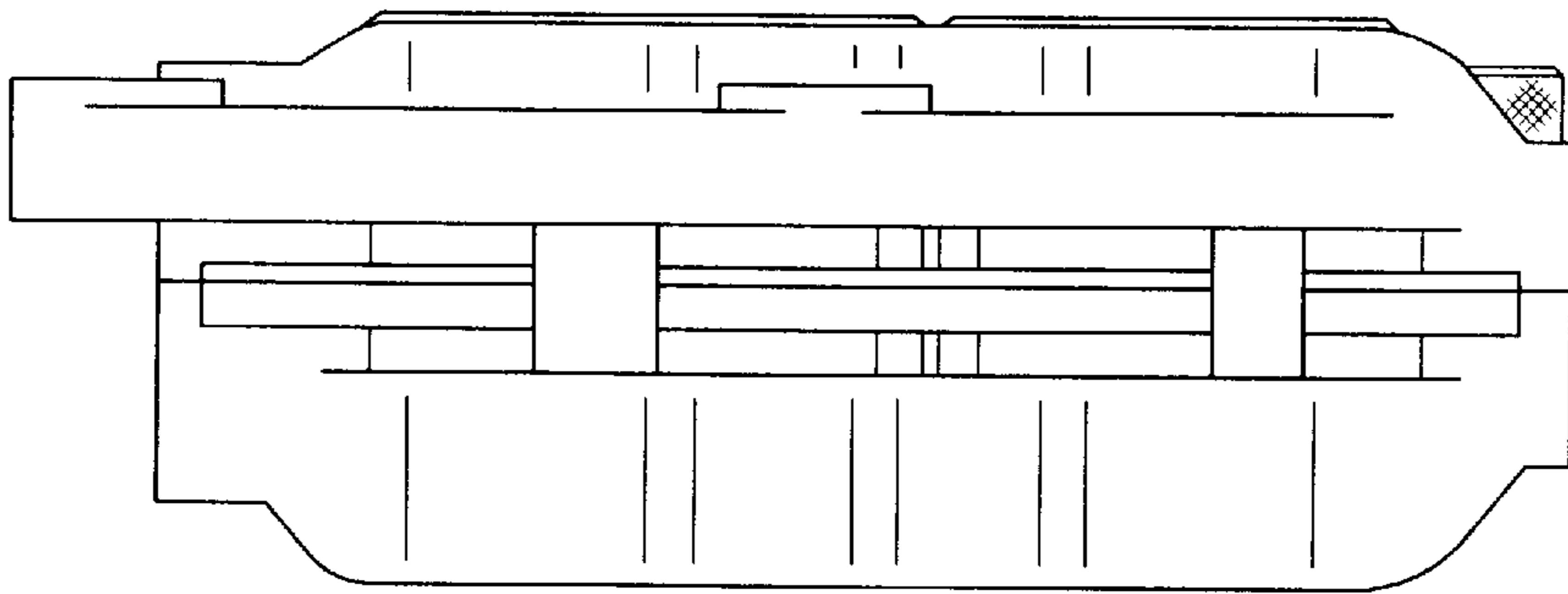

FIG. 4

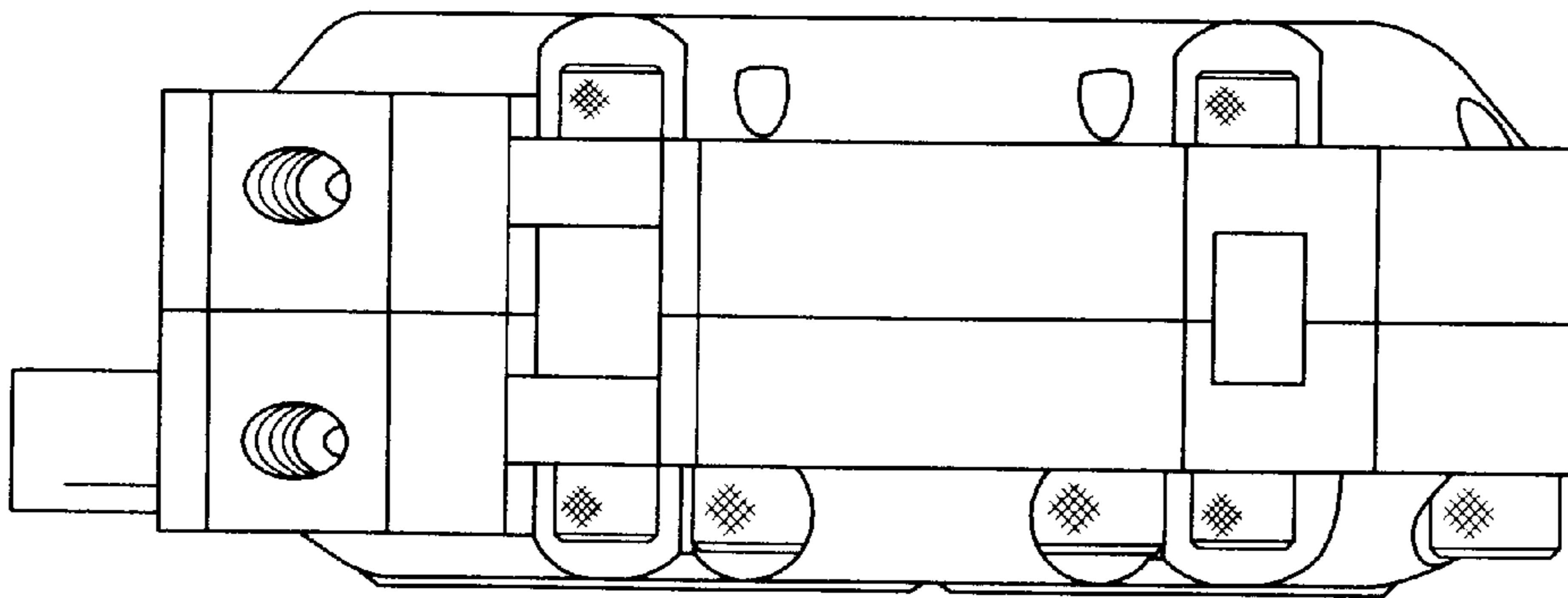

FIG. 5

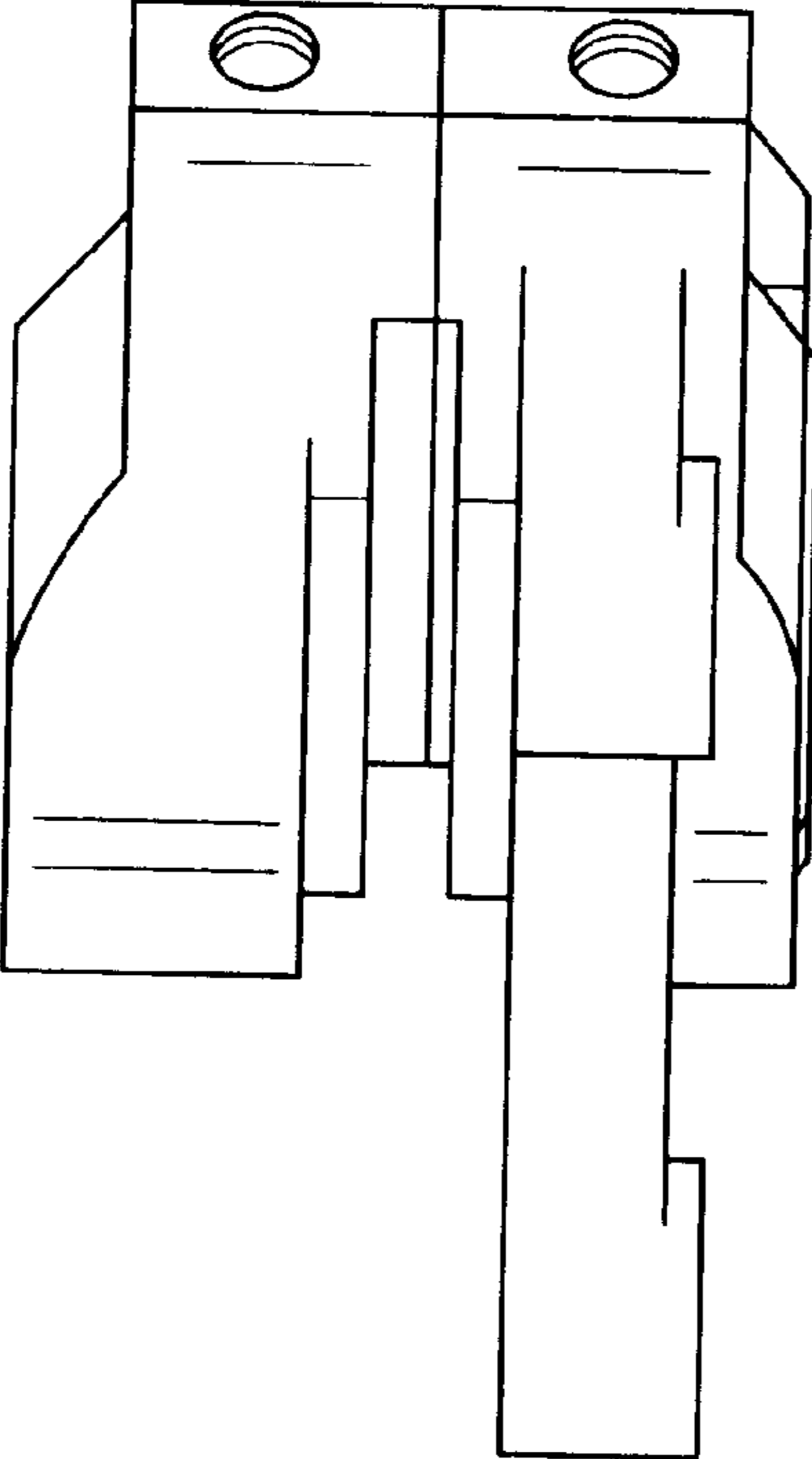

FIG.6

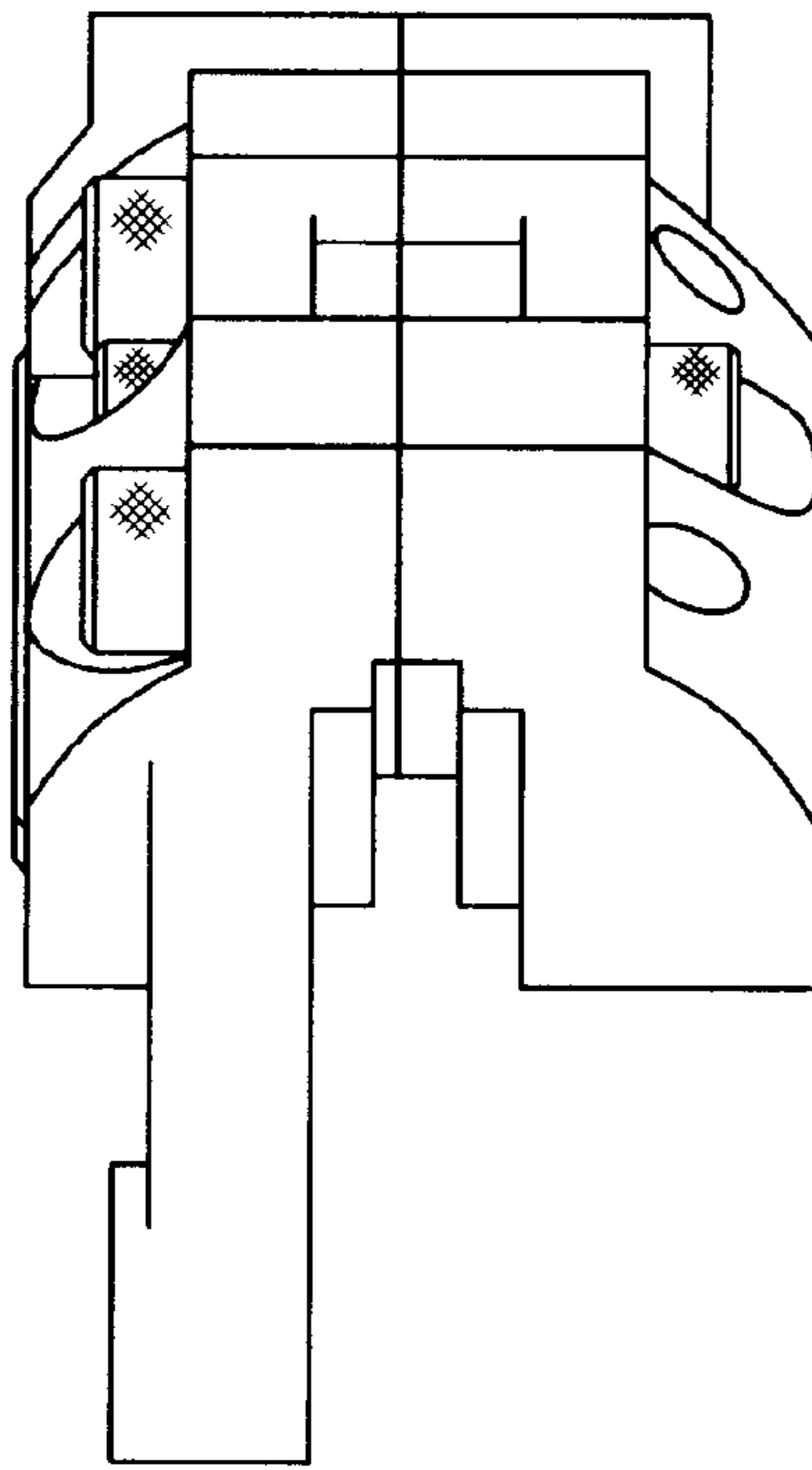

FIG. 7