

US00D494532S1

(12) **United States Design Patent** (10) **Patent No.:** **US D494,532 S**
Reese (45) **Date of Patent:** **** Aug. 17, 2004**

(54) **SET OF VEHICLE RACKS**

6,186,571 B1 * 2/2001 Burke 296/3
D444,446 S * 7/2001 Carter D12/406

(76) Inventor: **Loyd R. Reese**, Lot 17B Sumner Lesh Sub., Flat Lake, AK (US) 99652

* cited by examiner

(**) Term: **14 Years**

Primary Examiner—Stacia Cadmus
(74) *Attorney, Agent, or Firm*—Angenehm Law Firm, Ltd; N Paul Friederichs

(21) Appl. No.: **29/149,899**

(22) Filed: **Oct. 18, 2001**

(57) **CLAIM**

(51) **LOC (7) Cl.** **12-16**

The ornamental design for a set of vehicle racks as shown and described.

(52) **U.S. Cl.** **D12/406**

DESCRIPTION

(58) **Field of Search** D12/406, 414, D12/414.1; 224/400–405, 497, 531, 534–535, 563, 569, 502, 523; 296/3, 37.1, 37.6, 36, 26.09, 26.08; 248/242; 108/44; 414/462; 280/404, 490.1; D6/552–553, 567, 572; 211/182, 162, 175, 205–206, 35, 85.7, 103, 207, 193; 52/731.6, 731.8, 735.1, 736.1, 737.6

The ornamental design has joints of the appearance and location as shown.

FIG. 1 is a right side elevation view of one of the rack members of the set of vehicle racks;

FIG. 2 is a front elevation view of one of the rack members of the set of vehicle racks;

FIG. 3 is a left side elevation view of one of the rack members of the set of vehicle racks;

FIG. 4 is a top view of one of the rack members of the set of vehicle racks;

FIG. 5 is a rear elevation view of one of the rack members of the set of vehicle racks;

FIG. 6 is a bottom view of one of the rack members of the set of vehicle racks;

FIG. 7 is an exploded view of one of the rack members of the set of vehicle racks;

FIG. 8 is an exploded view of the embodiment shown in FIG. 7 and further showing an alternate position of the top portion;

FIG. 9 is a perspective view one of the rack members of the set of vehicle racks installed in a vehicle; and,

FIG. 10 is a perspective view of one of the rack members of the set of vehicle racks installed in a vehicle.

The broken line showing of environment is for illustrative purposes only and forms no part of the claimed design.

(56) **References Cited**

U.S. PATENT DOCUMENTS

2,678,150	A	*	5/1954	Lund	224/405
D236,973	S	*	9/1975	Burton	D12/406
D245,247	S	*	8/1977	Russell et al.	D12/406
D256,303	S	*	8/1980	Rieman	D6/552
4,630,990	A	*	12/1986	Whiting	414/462
4,751,981	A	*	6/1988	Mitchell et al.	296/3 X
4,989,768	A	*	2/1991	McNulty	296/3
5,004,133	A	*	4/1991	Wyers	224/405
D335,275	S	*	5/1993	Wright, Jr.	D12/406
5,350,095	A	*	9/1994	Stevens	224/405 X
D358,506	S	*	5/1995	Lara	D12/406 X
5,458,389	A	*	10/1995	Young	296/26
5,560,666	A	*	10/1996	Vieira et al.	296/3
5,649,656	A	*	7/1997	Davy	224/405
5,662,254	A	*	9/1997	Lemajeur et al.	224/405
5,788,133	A	*	8/1998	Mareno	224/406
D398,284	S	*	9/1998	Carter et al.	D12/406
5,810,542	A	*	9/1998	Ostrander	414/462
D436,915	S	*	1/2001	Burger	D12/406

1 Claim, 4 Drawing Sheets

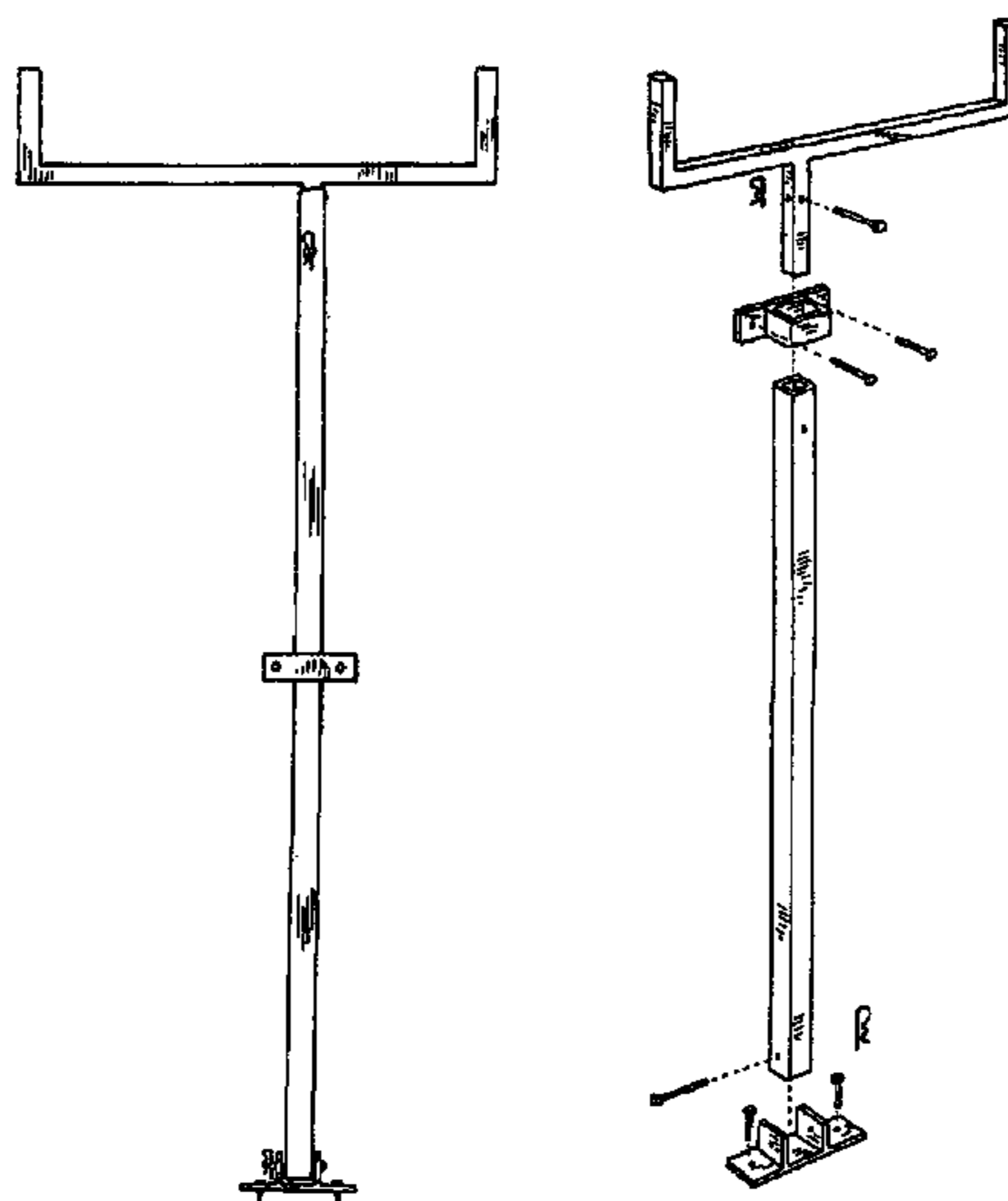

FIG. 1



FIG. 2

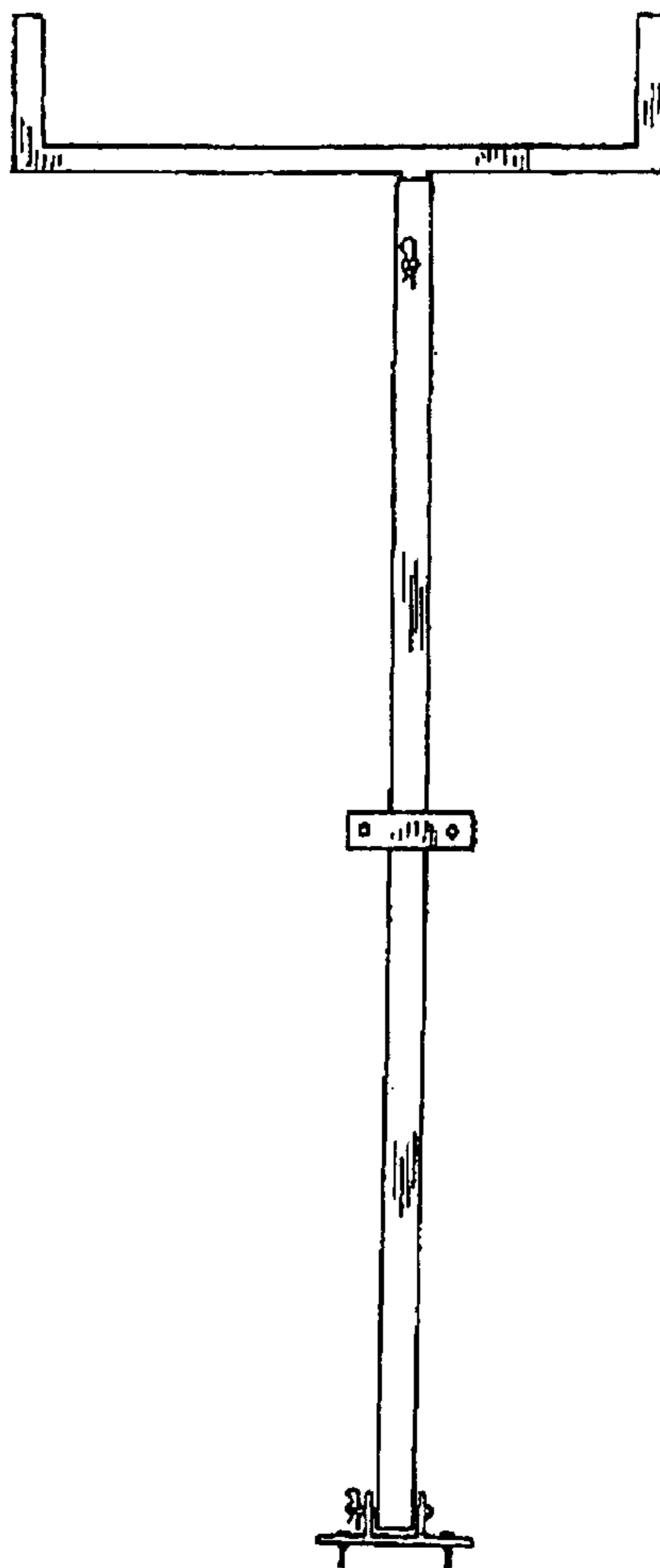

FIG. 3



FIG. 4

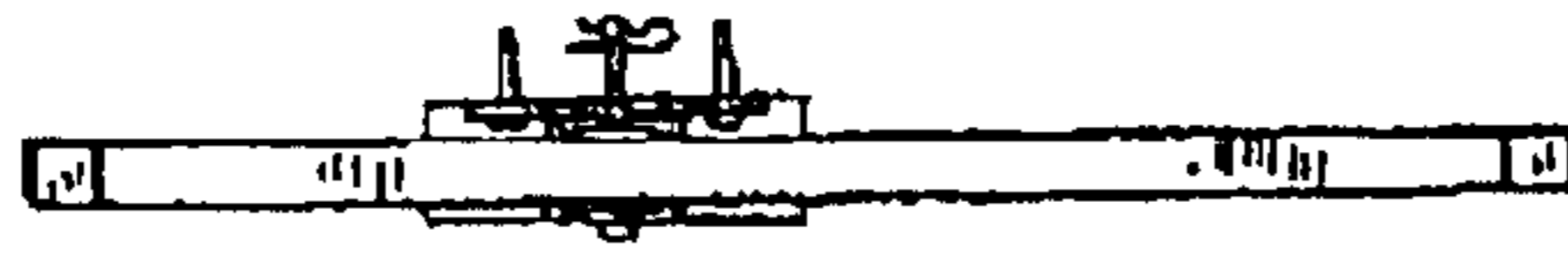

FIG. 5

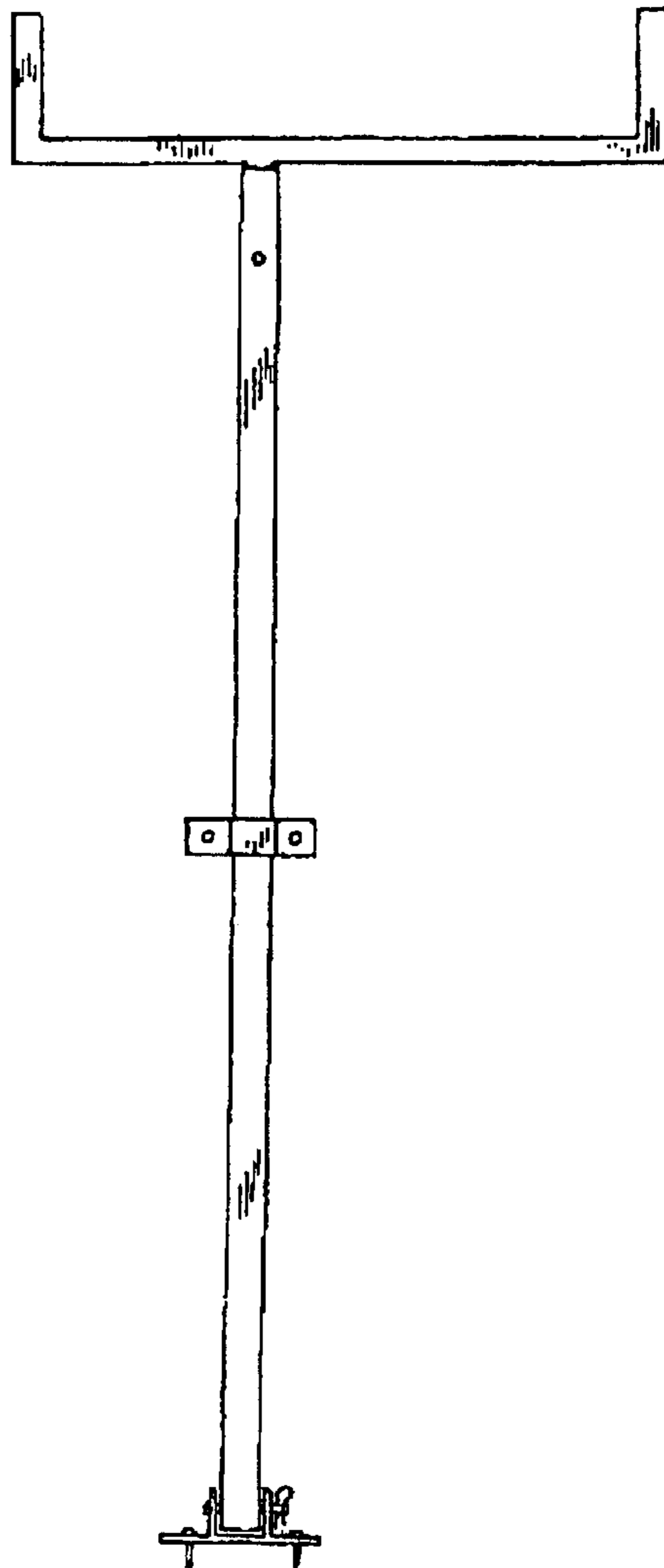

FIG. 6



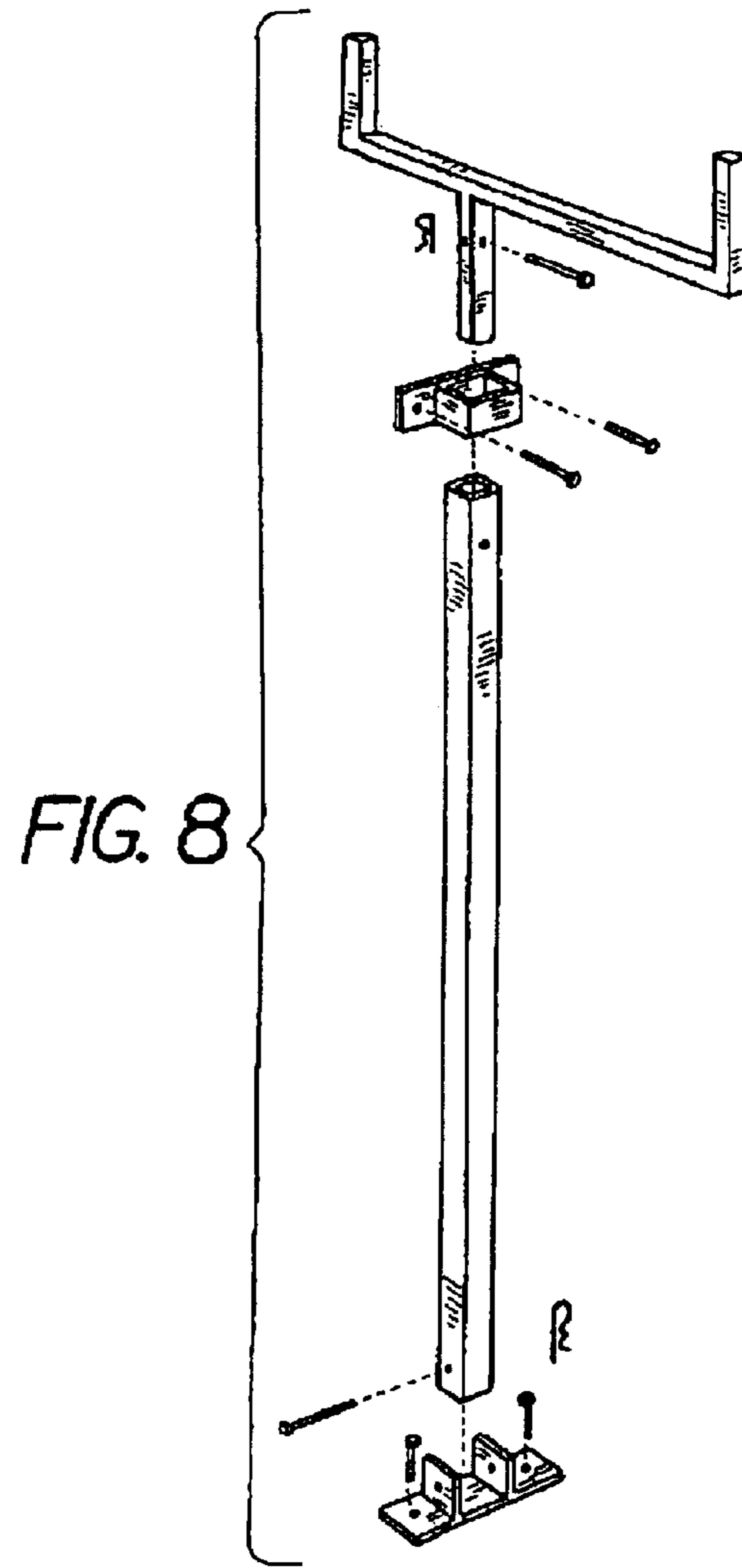
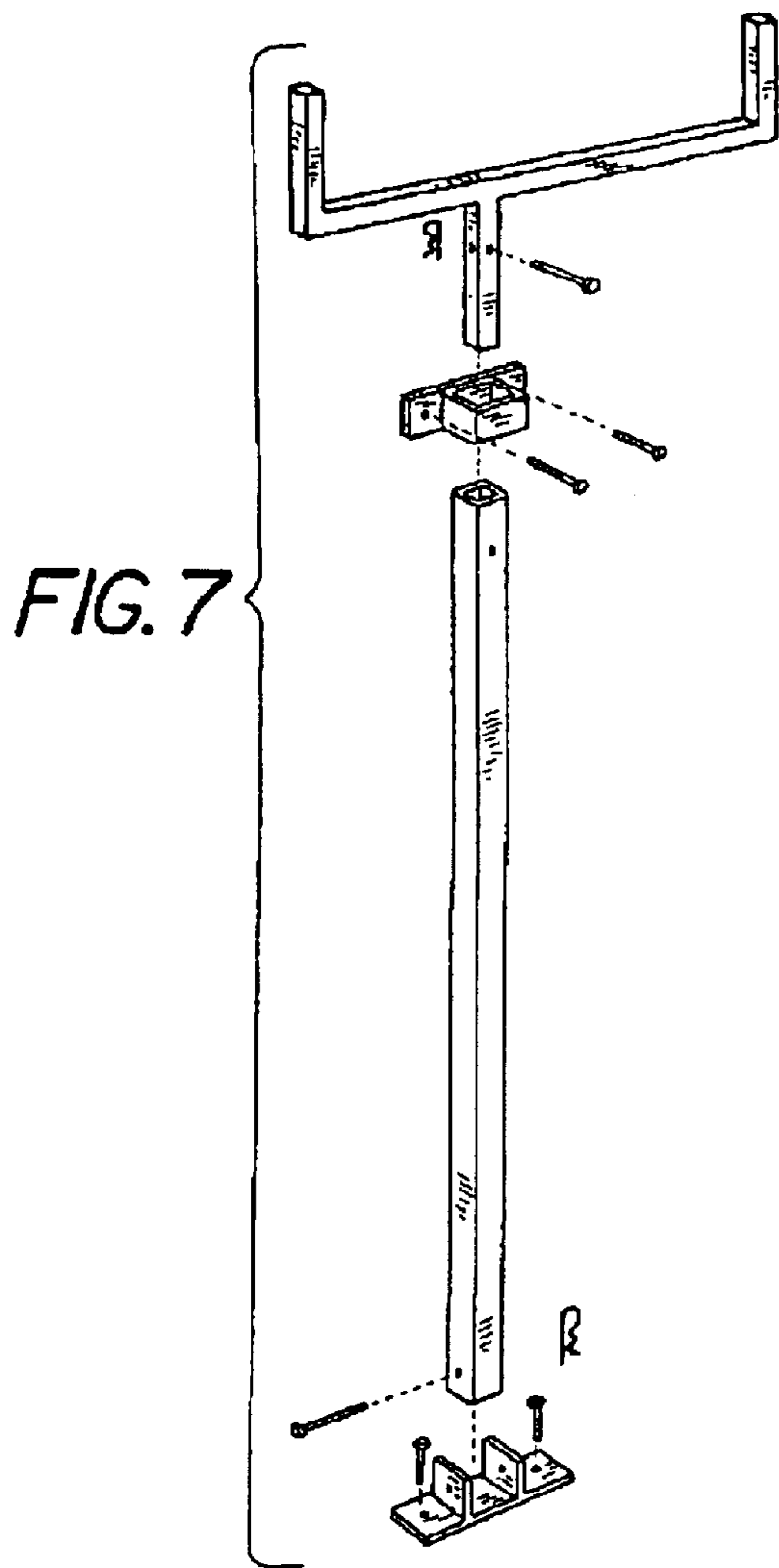

FIG. 9

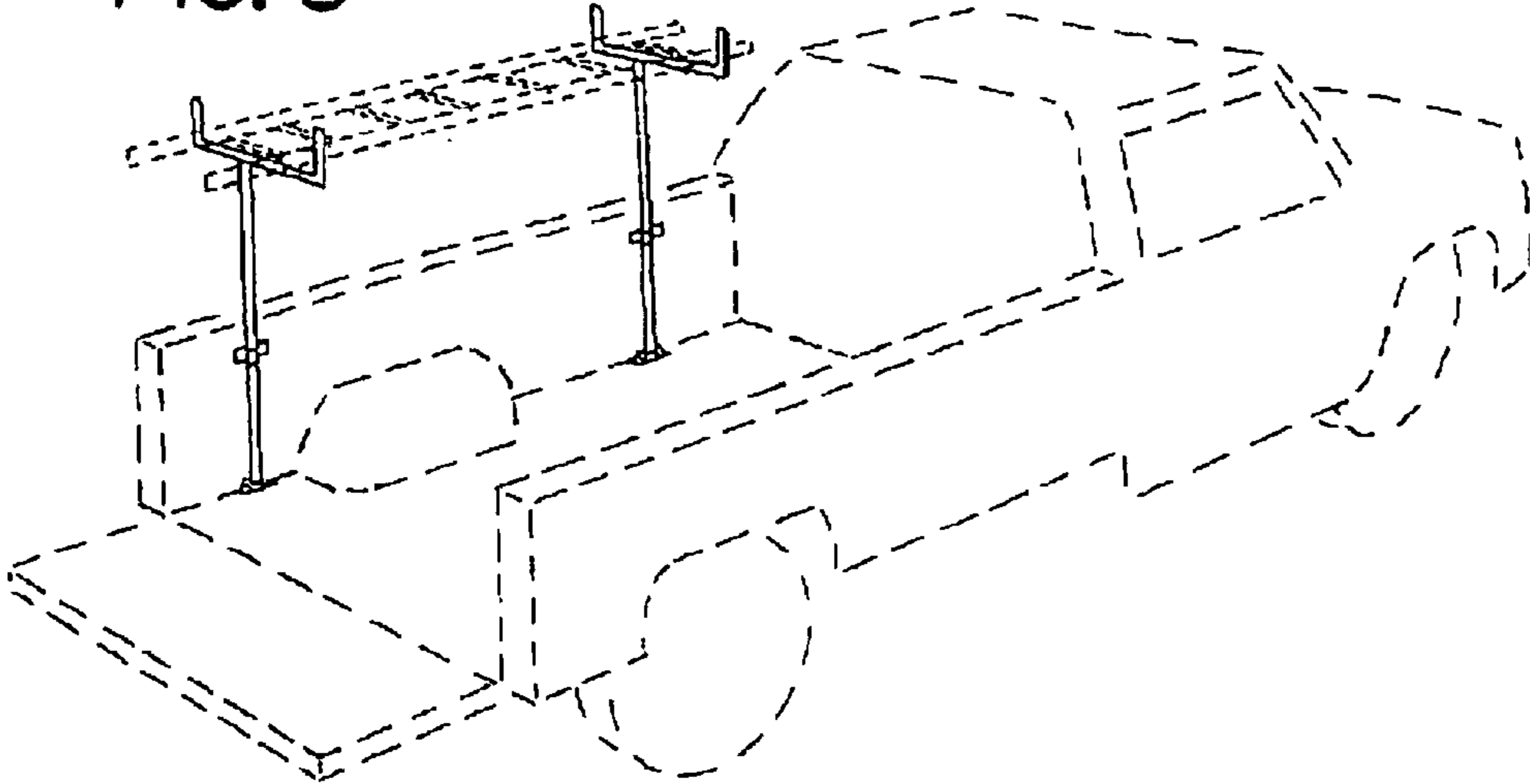

FIG. 10

