



US00D494516S1

(12) **United States Design Patent**
Swan et al.

(10) **Patent No.: US D494,516 S**

(45) **Date of Patent: ** Aug. 17, 2004**

(54) **STEERING WHEEL WITH STICK AND KNOB**

D479,168 S * 9/2003 Faust et al. D12/176

* cited by examiner

(75) Inventors: **Fred Swan**, Castro Valley, CA (US);
John Faust, Burlingame, CA (US);
Christopher Pate, Fremont, CA (US);
David McVicar, El Dorado, CA (US);
Vance Prather, Tracy, CA (US);
Manuel Tavano, San Donato Milanese (IT);
Paolo Cattaneo, Pavia (IT);
Klaus Fiorino, Magenta (IT); **Andrea Zardoni**, Villasanta (IT); **Masayuki Hotta**, Shinjuku-ku (JP); **Chau-Chang Chou**, Taichung (TW); **Ming Yu**, Taipei (TW)

Primary Examiner—Lisa Lichtenstein

(74) *Attorney, Agent, or Firm*—Townsend and Townsend and Crew LLP

(57) **CLAIM**

The ornamental design for a steering wheel with stick and knob, as shown and described.

DESCRIPTION

FIG. 1 is a perspective view of a steering wheel with stick and knob showing our new design;

FIG. 2 is a left side elevational view thereof;

FIG. 3 is a right side elevational view thereof;

FIG. 4 is a view taken along line 4—4 in FIG. 2;

FIG. 5 is a top plan view of FIG. 6;

FIG. 6 is a front elevational view taken along line 6—6 in FIG. 2;

FIG. 7 is a rear elevational view of FIG. 6; and,

FIG. 8 is a bottom plan view of FIG. 6.

The broken line showing of environmental structure is for illustrative purposes only and forms no part of the claimed design.

(73) Assignee: **Logitech Europe S.A.** (CH)

(**) Term: **14 Years**

(21) Appl. No.: **29/183,088**

(22) Filed: **Jun. 4, 2003**

(51) **LOC (7) Cl.** **12-16**

(52) **U.S. Cl.** **D12/176**

(58) **Field of Search** D12/176, 175,
D12/179; 74/552, 558, 558.5

(56) **References Cited**

U.S. PATENT DOCUMENTS

D463,764 S * 10/2002 Swan et al. D12/176

1 Claim, 4 Drawing Sheets

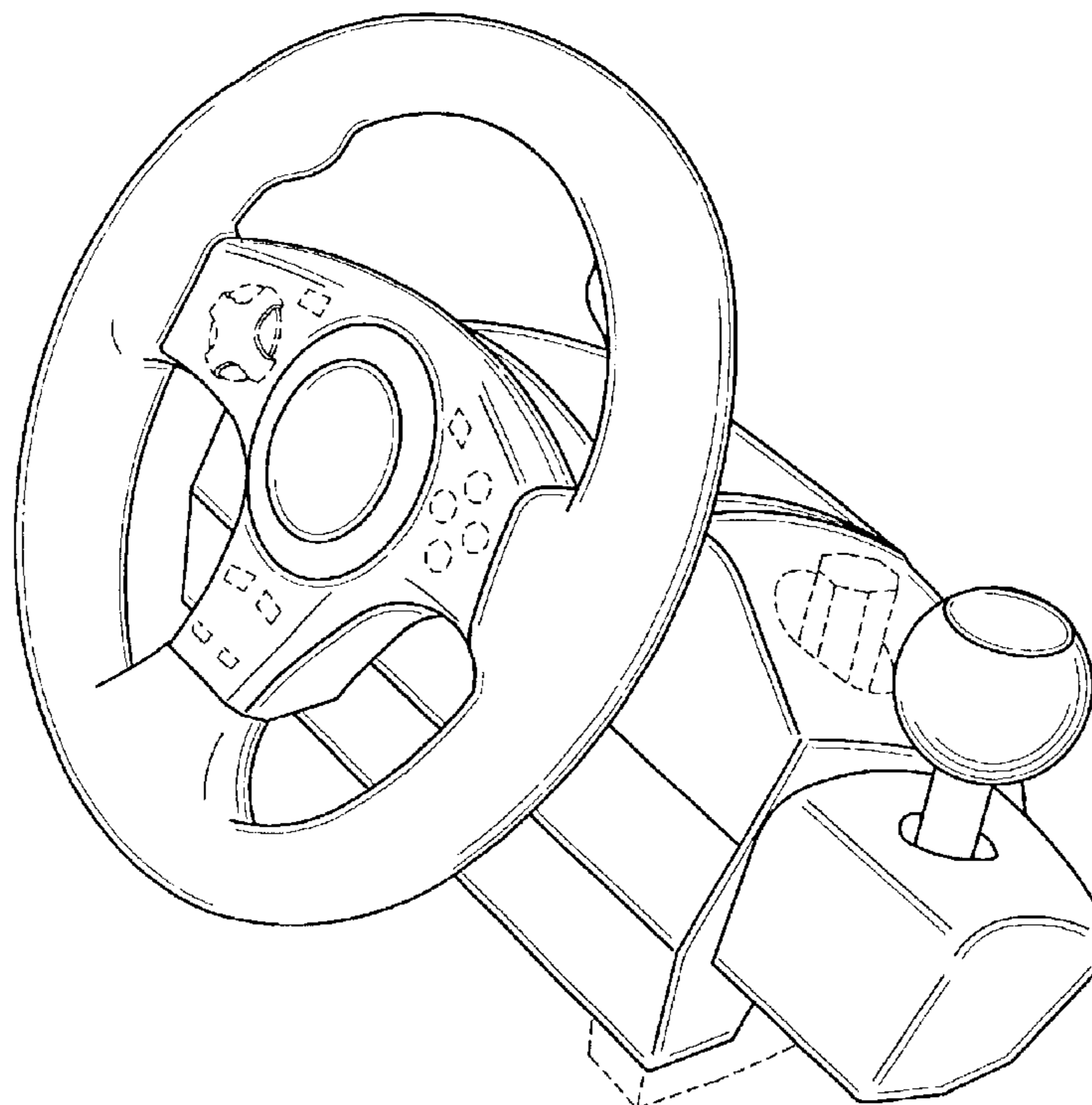

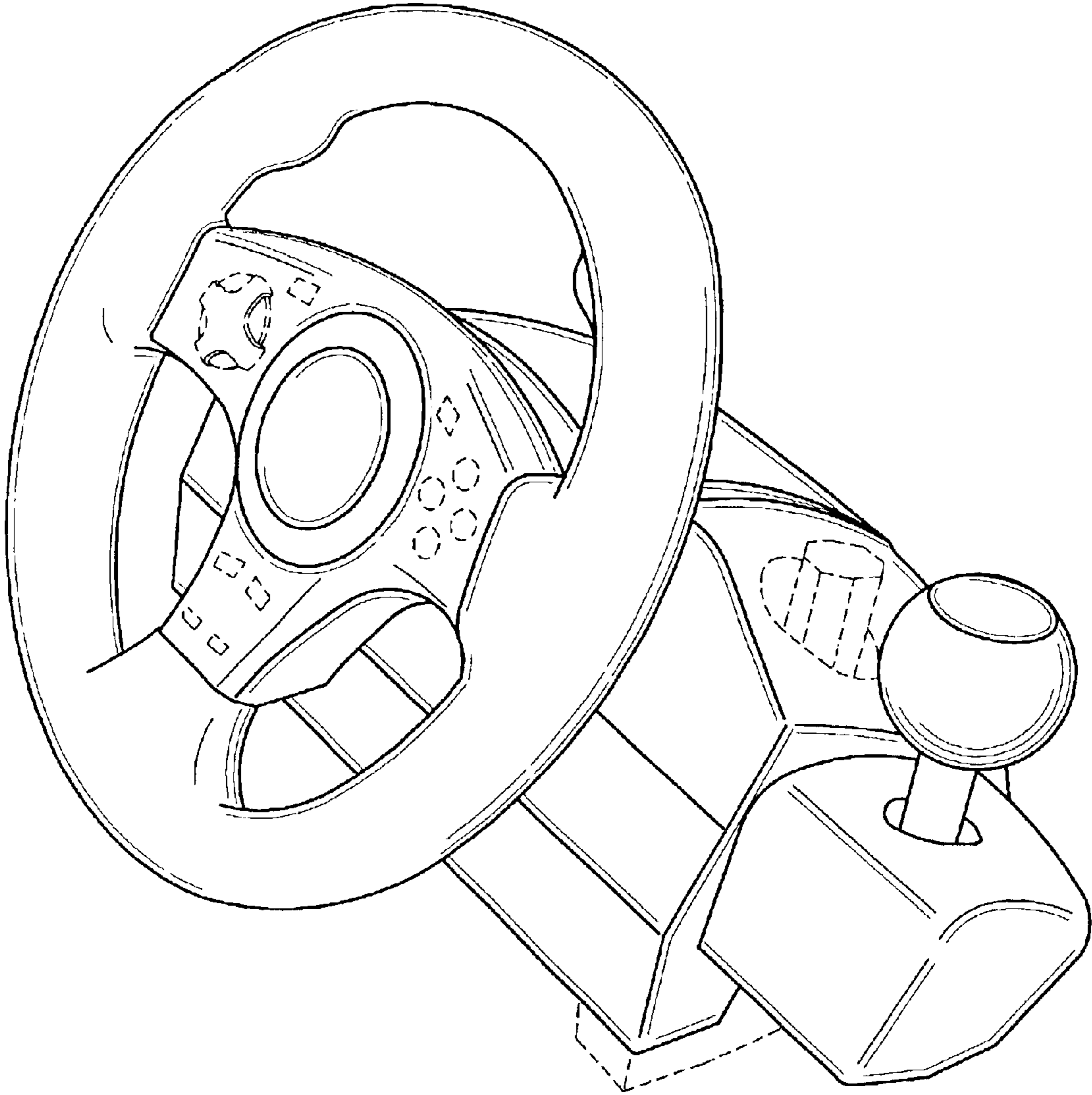
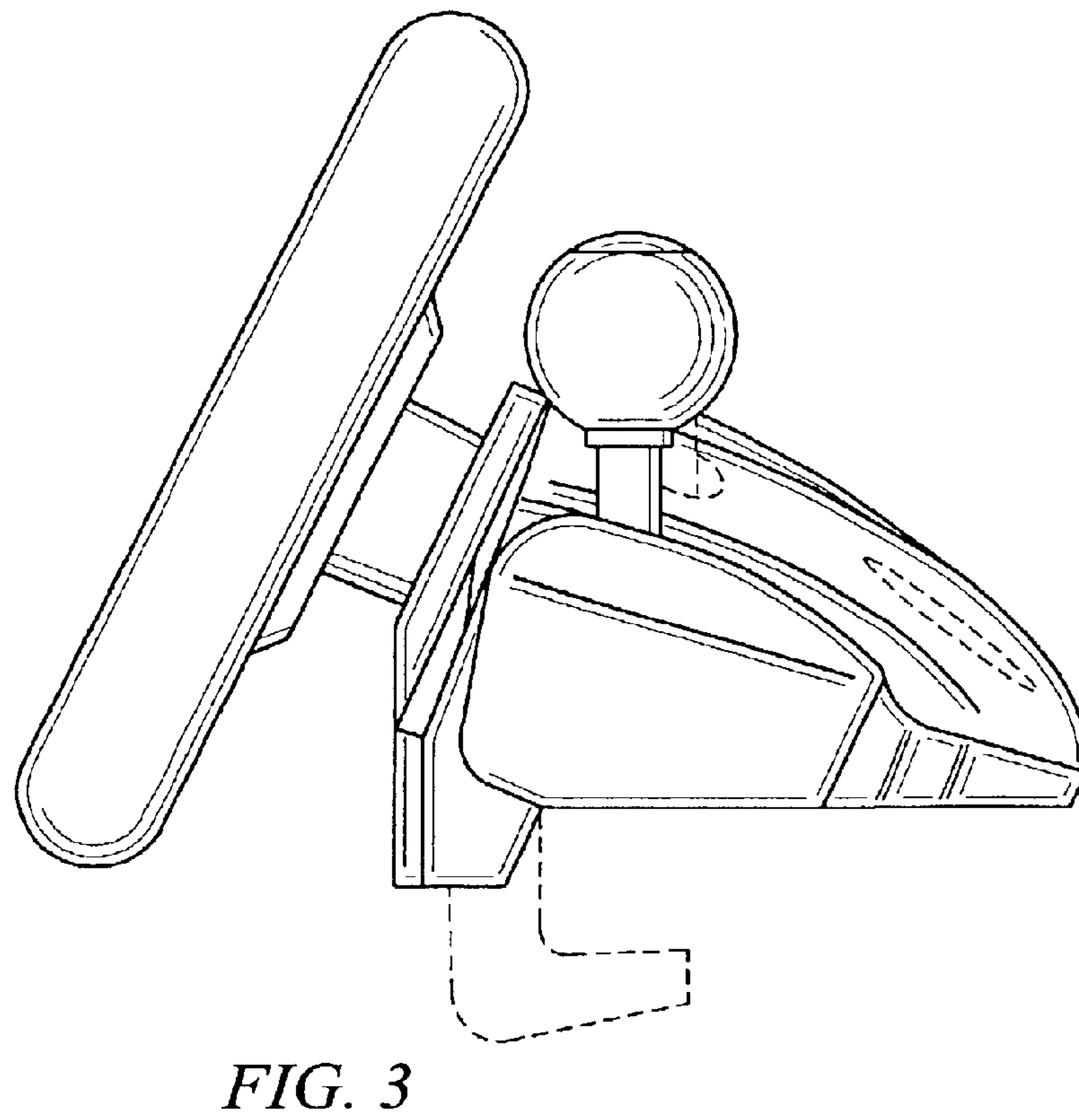
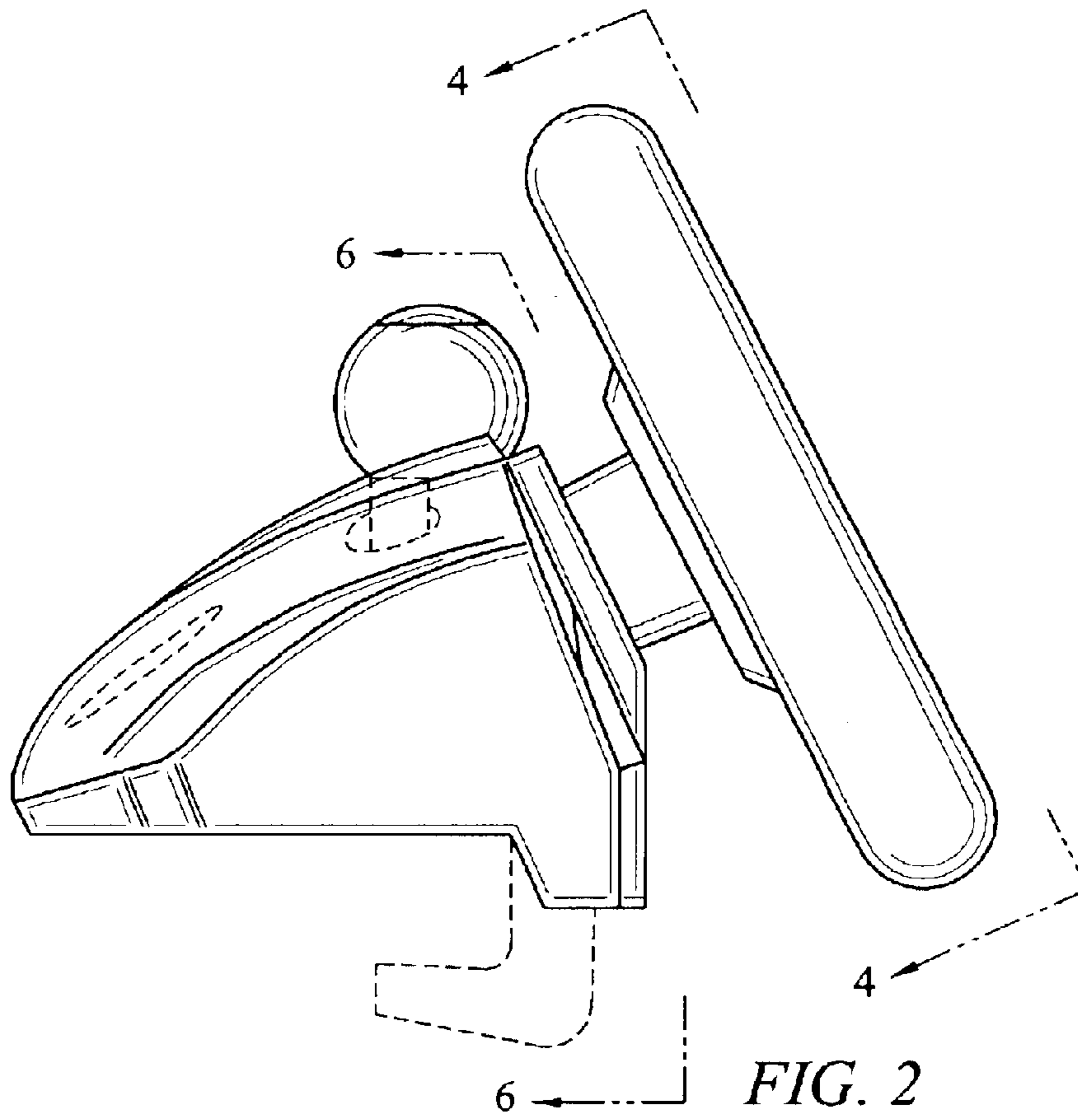

FIG. 1



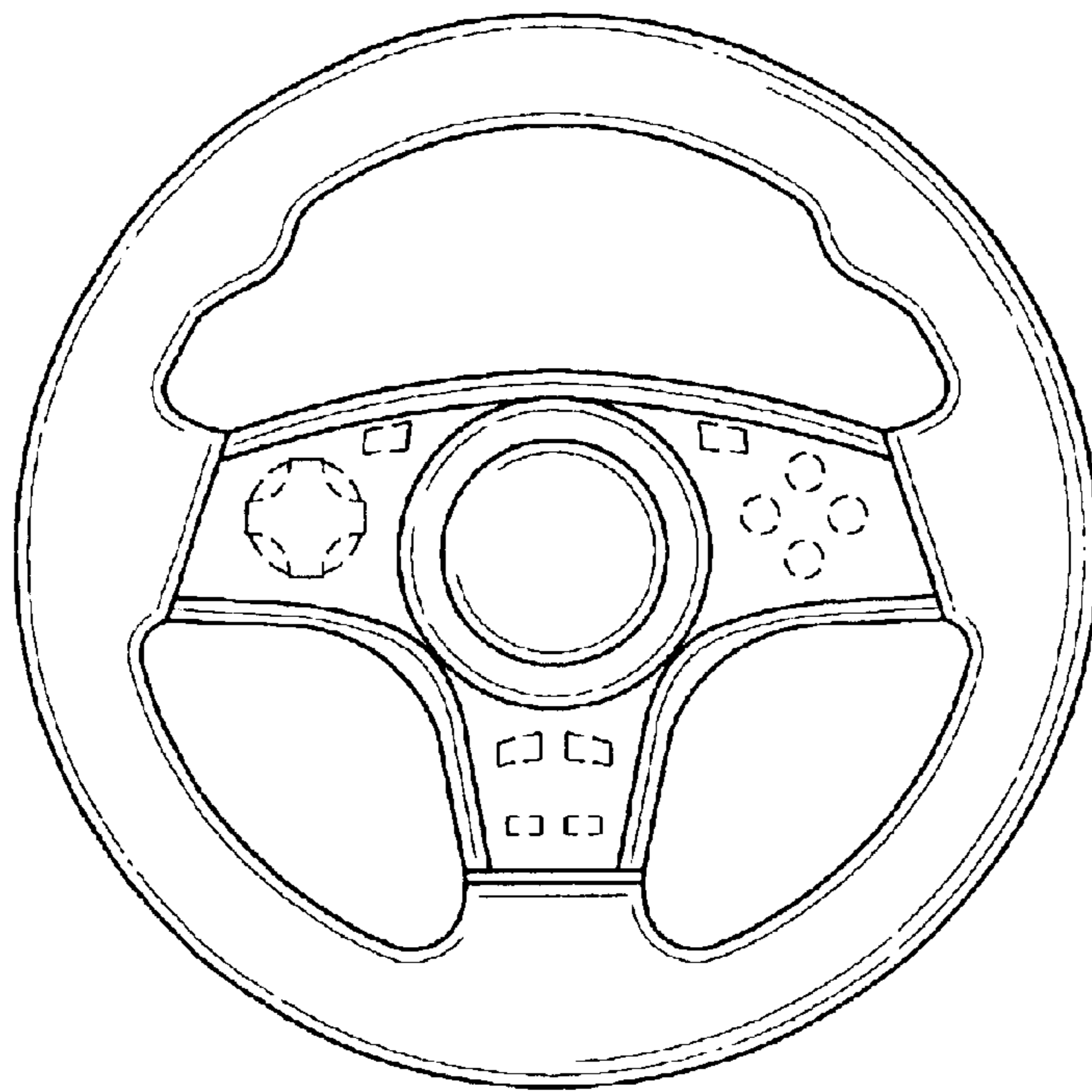

FIG. 4

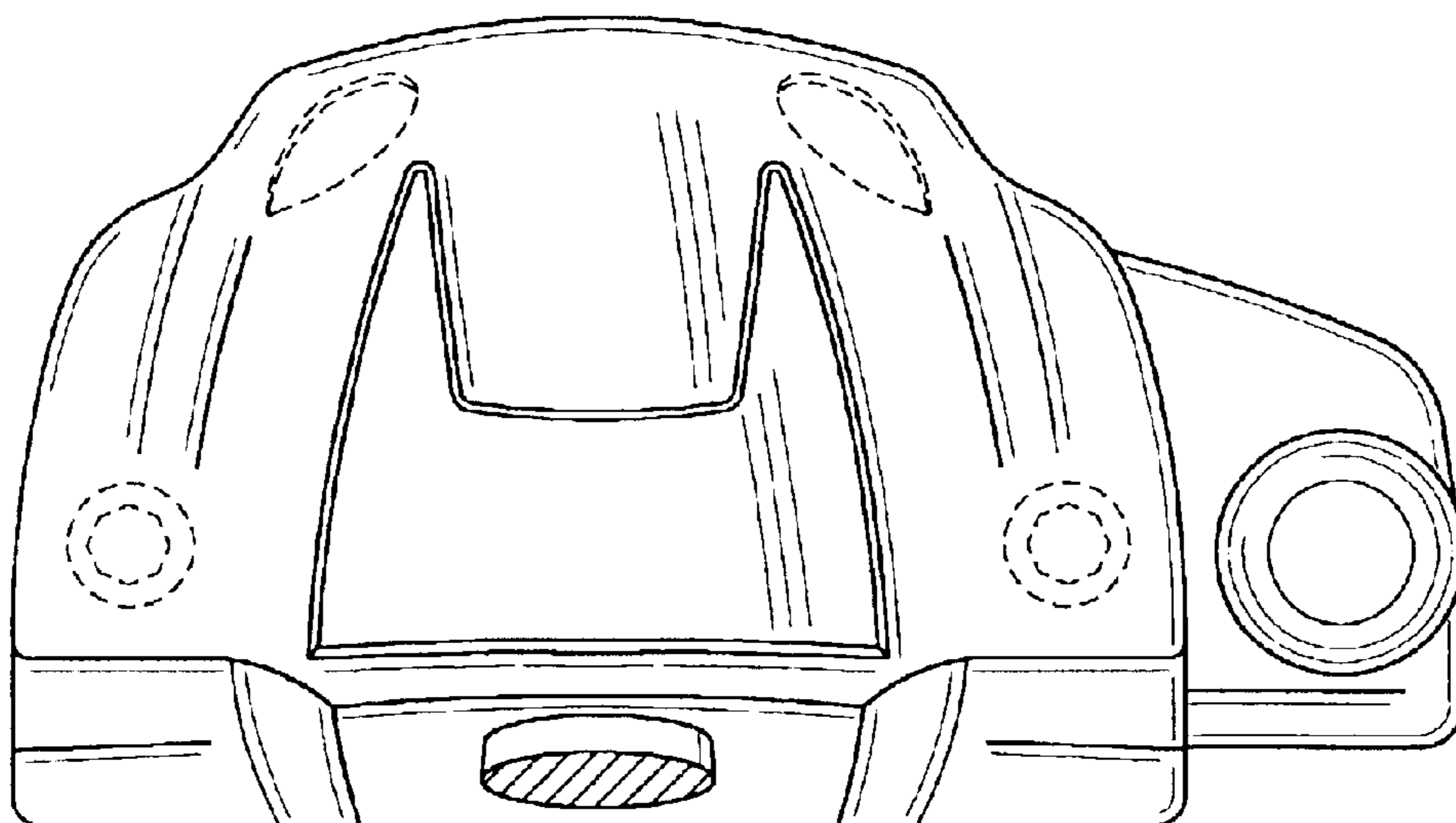

FIG. 5

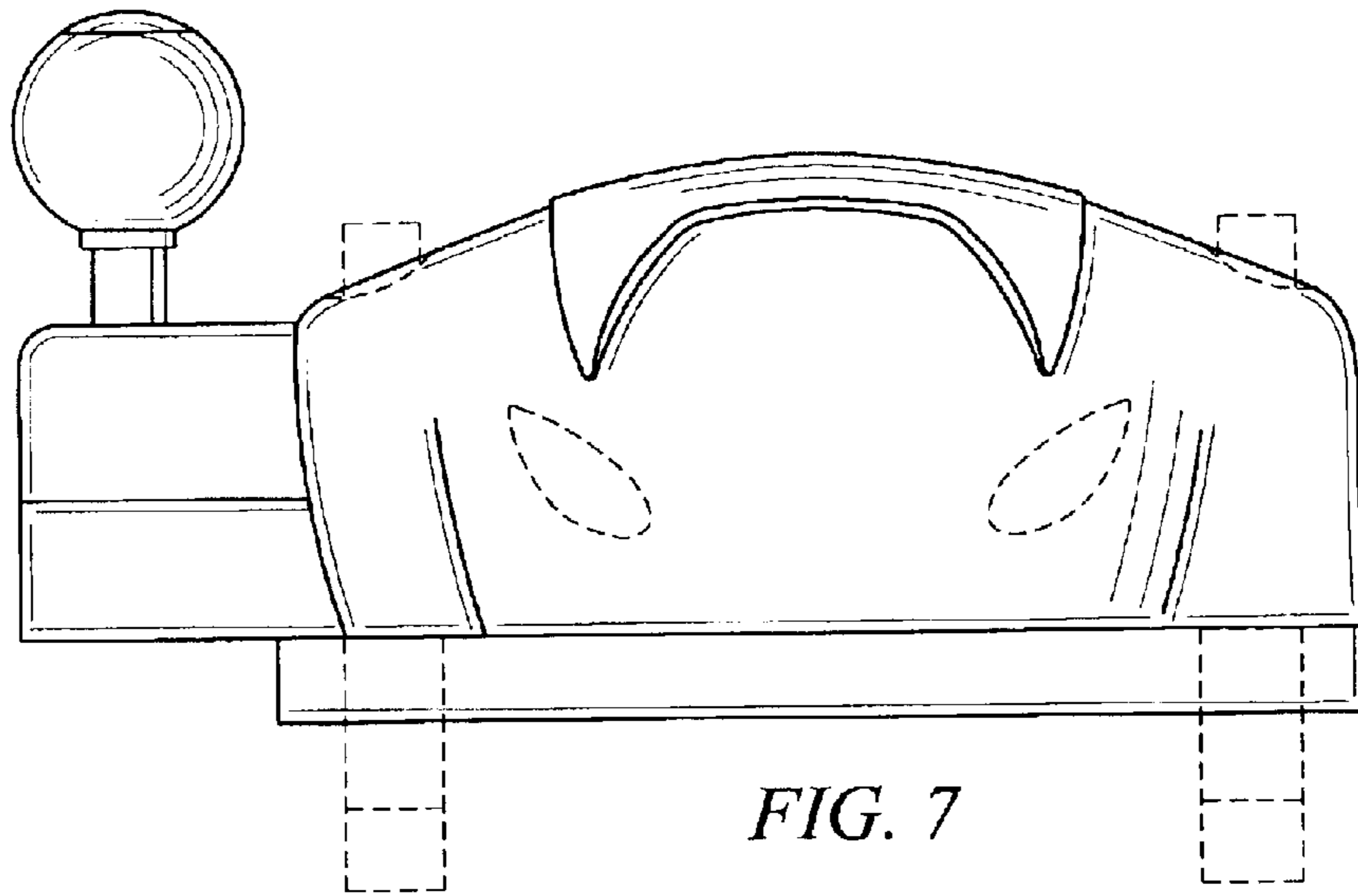
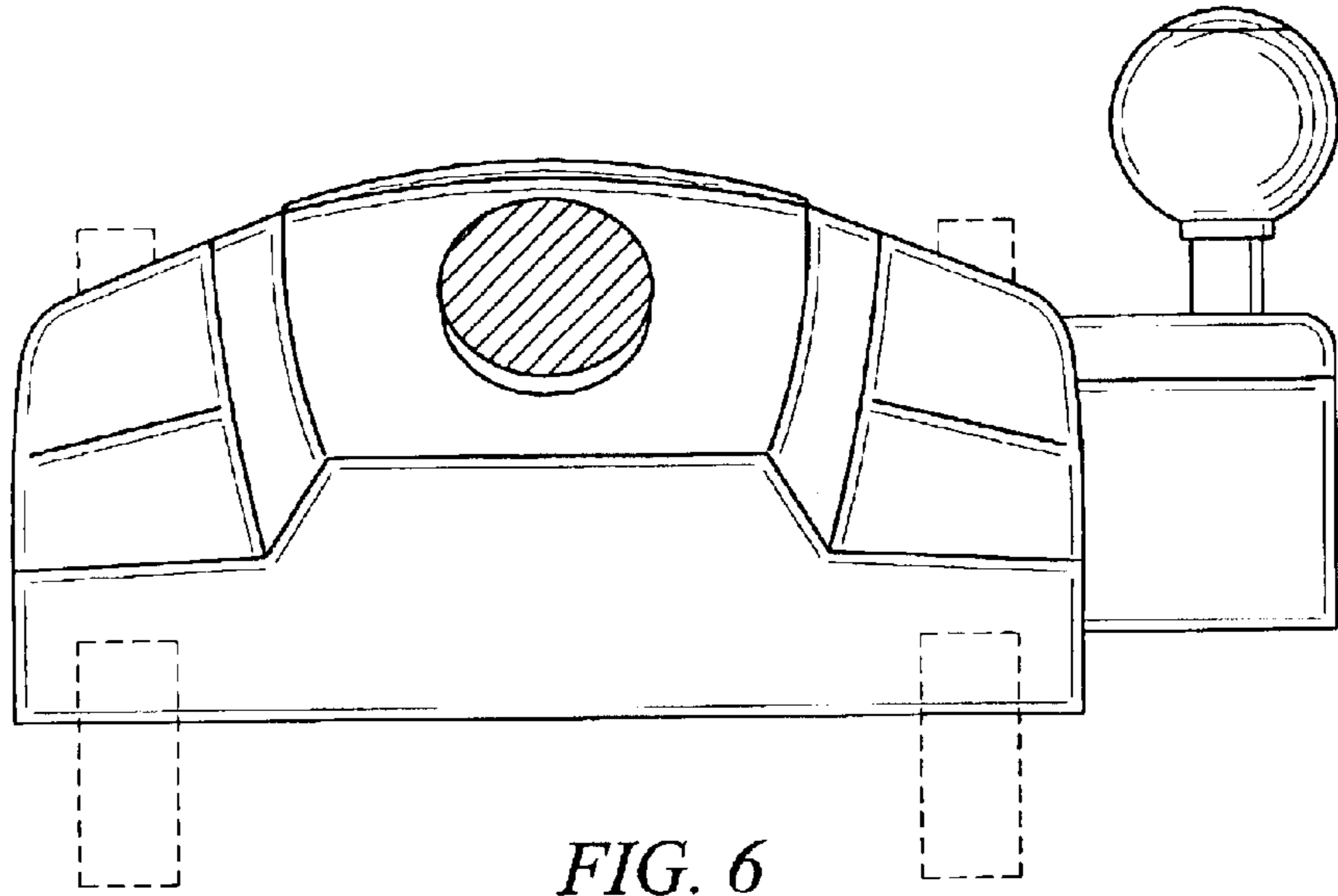

FIG. 8

