

US00D494322S1

(12) **United States Design Patent** (10) **Patent No.:** **US D494,322 S**  
**Winkler** (45) **Date of Patent:** **\*\* Aug. 10, 2004**

(54) **BATTERY-OPERATED TOOTHPICK**

D458,412 S 6/2002 Bojar ..... D28/65  
6,422,867 B2 \* 7/2002 Lang et al. .... 433/118

(75) Inventor: **Till Winkler**, Kronberg (DE)

**FOREIGN PATENT DOCUMENTS**

(73) Assignee: **The Gillette Company**, Boston, MA  
(US)

DE 40004796.9 7/2000

(\*\*) Term: **14 Years**

**OTHER PUBLICATIONS**

(21) Appl. No.: **29/186,896**

Sullivan-Schein Dental catalog, 2002, p. 493, "Water Pik"  
Battery-powered Flosser.\*

(22) Filed: **Jul. 24, 2003**

\* cited by examiner

(30) **Foreign Application Priority Data**

*Primary Examiner*—Lucy Lieberman

Jan. 27, 2003 (WO) ..... DM/062 879

(74) *Attorney, Agent, or Firm*—Fish & Richardson P.C.

(51) **LOC (7) Cl.** ..... **28-03**

(57) **CLAIM**

(52) **U.S. Cl.** ..... **D28/65**

The ornamental design for a battery-operated toothpick, as  
shown and described.

(58) **Field of Search** ..... D28/65, 66, 68;  
132/321–329; D24/152; 433/141, 146, 147

**DESCRIPTION**

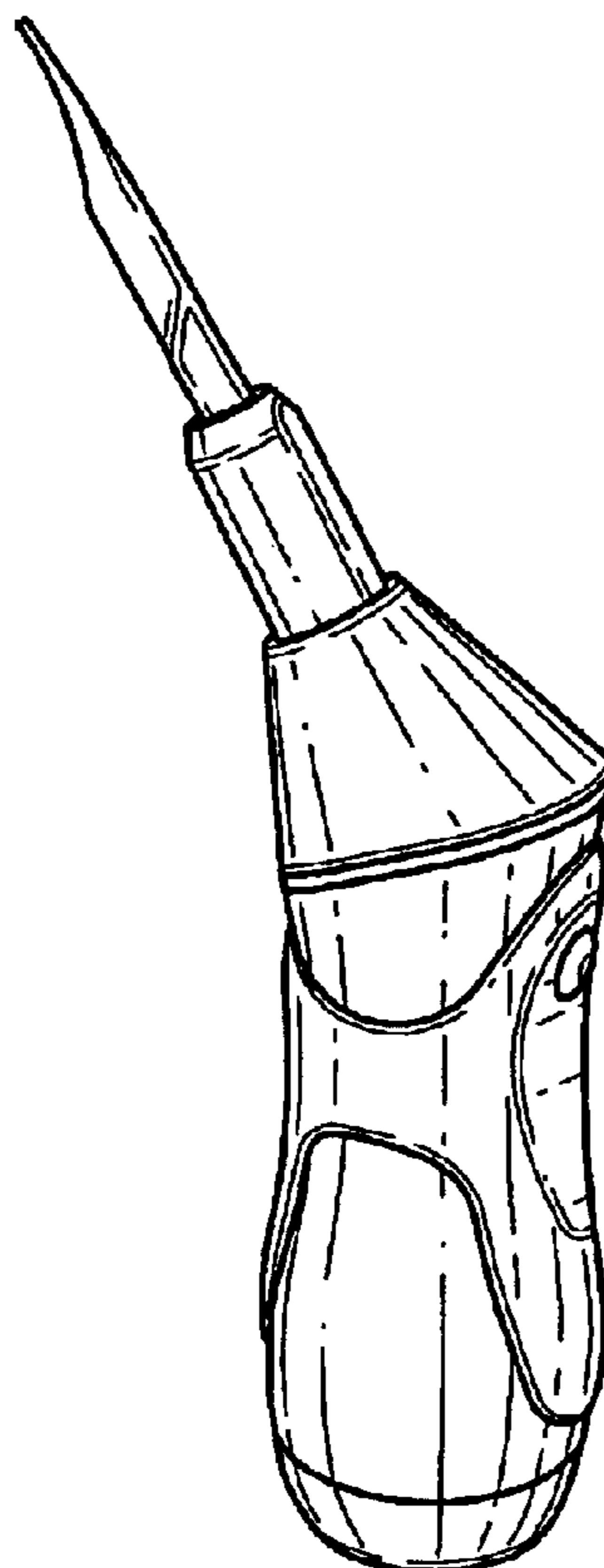
(56) **References Cited**

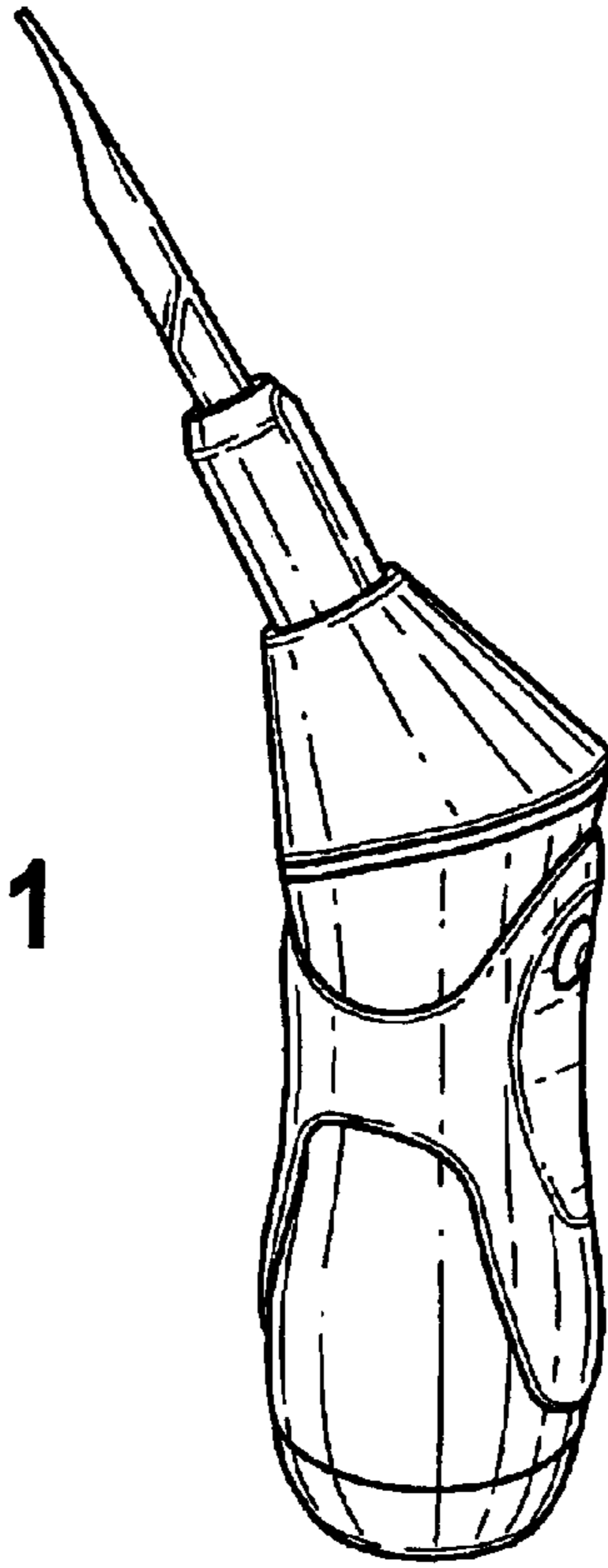
FIG. 1 is a perspective view of a battery-operated toothpick  
showing my new design;  
FIG. 2 is a front view of the appliance;  
FIG. 3 is a right side view of the appliance;  
FIG. 4 is a rear view of the appliance;  
FIG. 5 is a left side view of the appliance;  
FIG. 6 is a top plan view of the appliance; and,  
FIG. 7 is a bottom plan view of the appliance.

**U.S. PATENT DOCUMENTS**

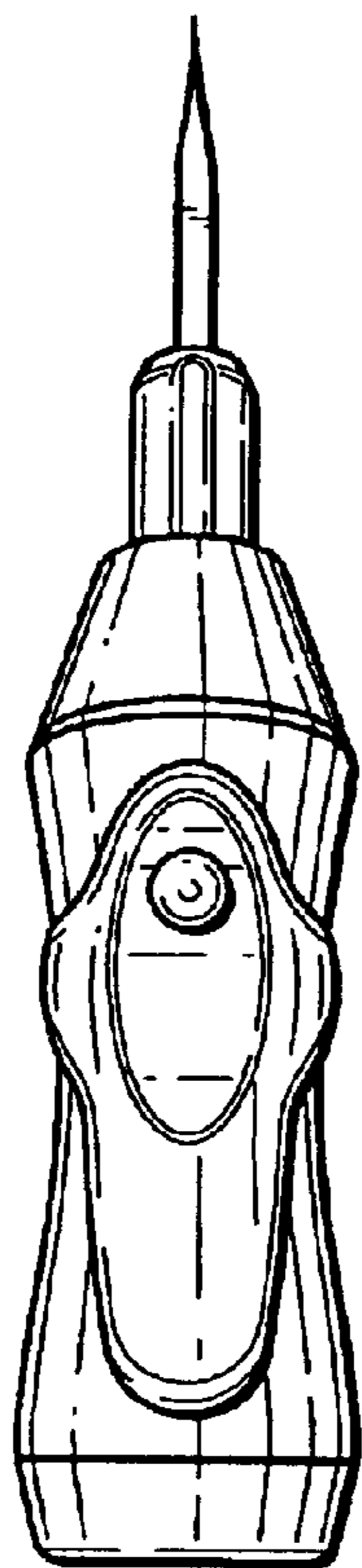
186,952 A	*	2/1877	Poznanski	.....	132/328
1,355,037 A	*	10/1920	Dziuk	.....	132/328
D251,513 S	*	4/1979	Kent	.....	D28/68
4,605,025 A	*	8/1986	McSpadden	.....	132/322
5,069,233 A	*	12/1991	Ritter	.....	132/322
5,573,020 A	*	11/1996	Robinson	.....	132/322
D398,077 S	*	9/1998	Young	.....	D28/66

**1 Claim, 2 Drawing Sheets**

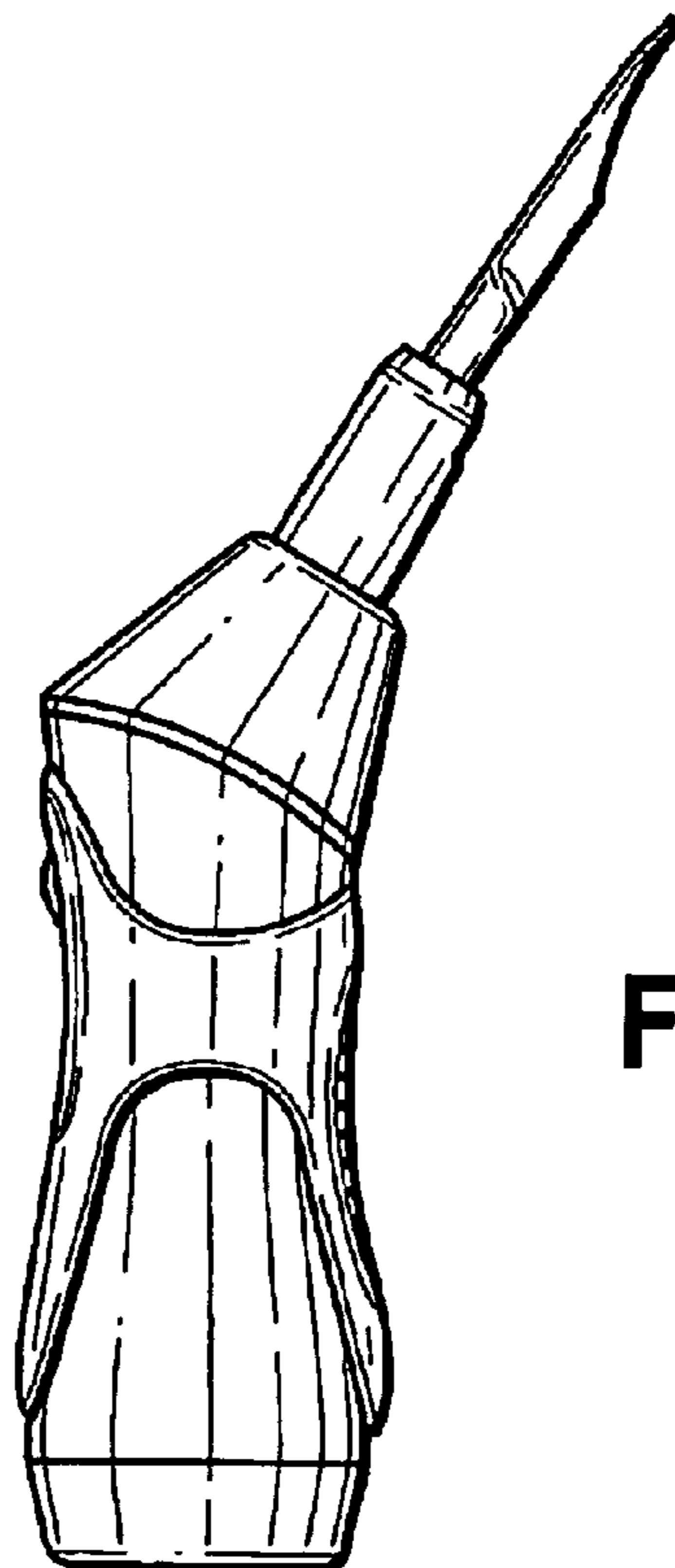




**Fig. 1**

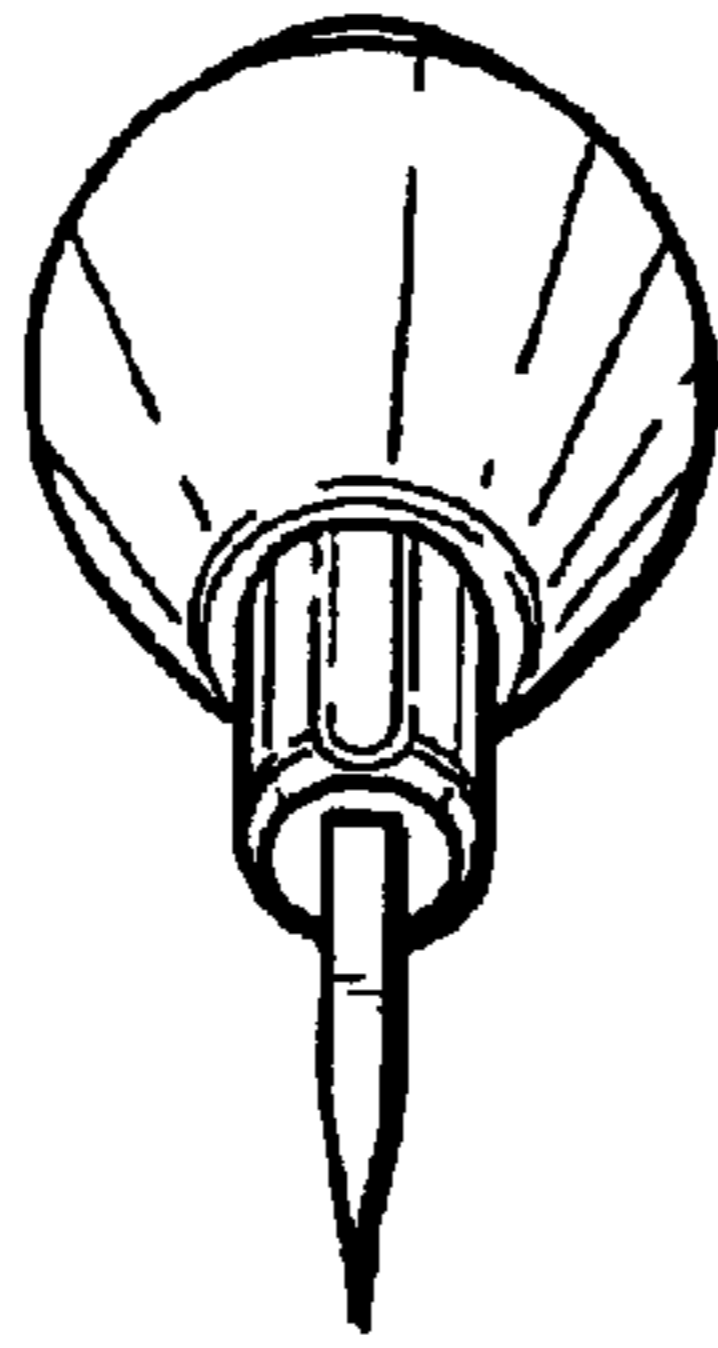


**Fig. 2**

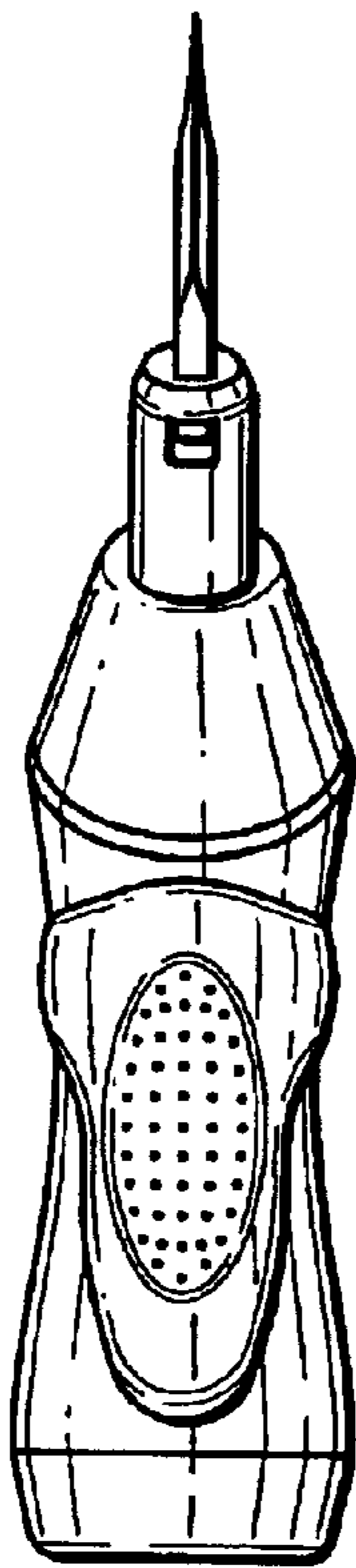


**Fig. 3**

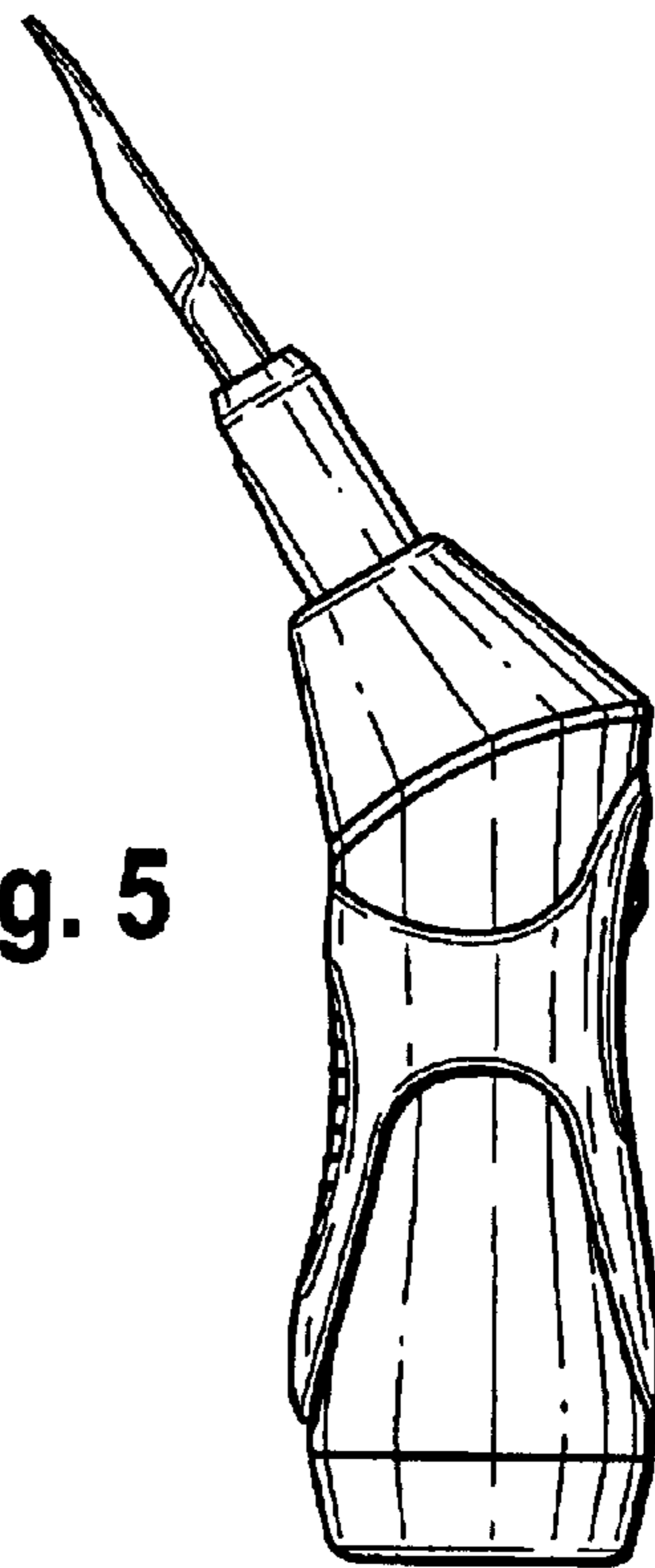
**Fig. 6**



**Fig. 4**



**Fig. 5**



**Fig. 7**

