

US00D494158S1

(12) **United States Design Patent**
Warden

(10) **Patent No.:** **US D494,158 S**

(45) **Date of Patent:** **** Aug. 10, 2004**

(54) **TONE ARM ASSEMBLY**

(75) **Inventor:** **Robert A. Warden**, Providence, RI (US)

(73) **Assignee:** **Numark Industries, LLC**, Cumberland, RI (US)

(**) **Term:** **14 Years**

(21) **Appl. No.:** **29/175,614**

(22) **Filed:** **Feb. 6, 2003**

(51) **LOC (7) Cl.** **14-01**

(52) **U.S. Cl.** **D14/262**

(58) **Field of Search** D14/199-203,
D14/261-263, 168; 369/63, 127, 153, 141,
244, 232, 234, 237, 266, 268, 271

(56) **References Cited**

U.S. PATENT DOCUMENTS

D179,570 S	*	1/1957	Heintze	D14/262
3,552,816 A		1/1971	Wolanin		
4,004,817 A	*	1/1977	Shimoda et al.	369/244
4,054,291 A		10/1977	Maeda	274/39 R
D247,488 S		3/1978	Ohtomo	D14/17
4,118,037 A		10/1978	Ngai	274/1 A
D250,333 S		11/1978	Meunier	D14/17
D250,334 S		11/1978	Meunier	D14/17
D252,330 S		7/1979	Leech	D17/17
D252,393 S		7/1979	Kashidaira	D14/17
4,189,155 A		2/1980	Ngai	274/1 A
D256,461 S		8/1980	Guillon	D14/25
D256,462 S		8/1980	Vachus	D14/25
D258,652 S		3/1981	Guillon	D14/25

D258,653 S		3/1981	Vachus	D14/25
D260,766 S		9/1981	Vachus	D14/25
D261,388 S		10/1981	Vachus	D14/25
D277,178 S	*	1/1985	Morita	D14/203
4,524,438 A		6/1985	Einhaus	369/75.1
D282,839 S	*	3/1986	Vinogradov et al.	D14/262
4,734,902 A		3/1988	Dennis et al.	369/176
4,788,676 A		11/1988	Dennis	369/176
5,040,164 A		8/1991	Liu	369/268
D433,011 S	*	10/2000	O'Donnell et al.	D14/202
6,469,974 B1	*	10/2002	Kaneko	369/127

* cited by examiner

Primary Examiner—Nanda Bondade

(74) *Attorney, Agent, or Firm*—Barlow, Josephs & Holmes, Ltd.

(57) **CLAIM**

The ornamental design for a tone arm assembly, as shown and described.

DESCRIPTION

FIG. 1 is a front perspective view of a tone arm assembly showing my new design;
FIG. 2 is a top view thereof;
FIG. 3 is a bottom view thereof;
FIG. 4 is a front elevational view thereof;
FIG. 5 is a rear elevational view thereof;
FIG. 6 is a left elevational view thereof; and,
FIG. 7 is a right elevational view thereof.
The broken line showing of a tone arm tube and cartridge on FIGS. 1-4 and 6-7 is for illustrative purposes only and forms no part of the claimed design.

1 Claim, 7 Drawing Sheets

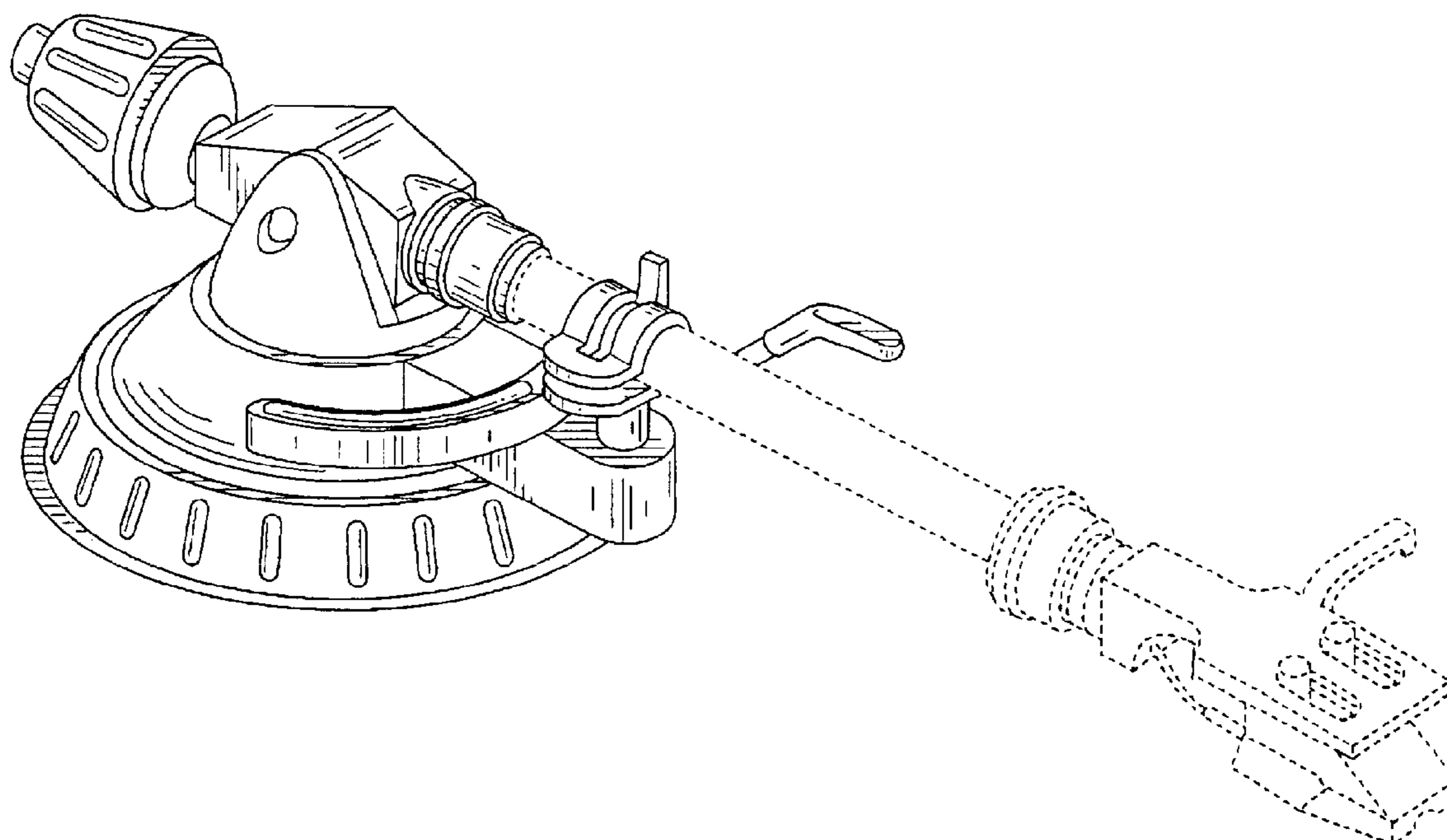

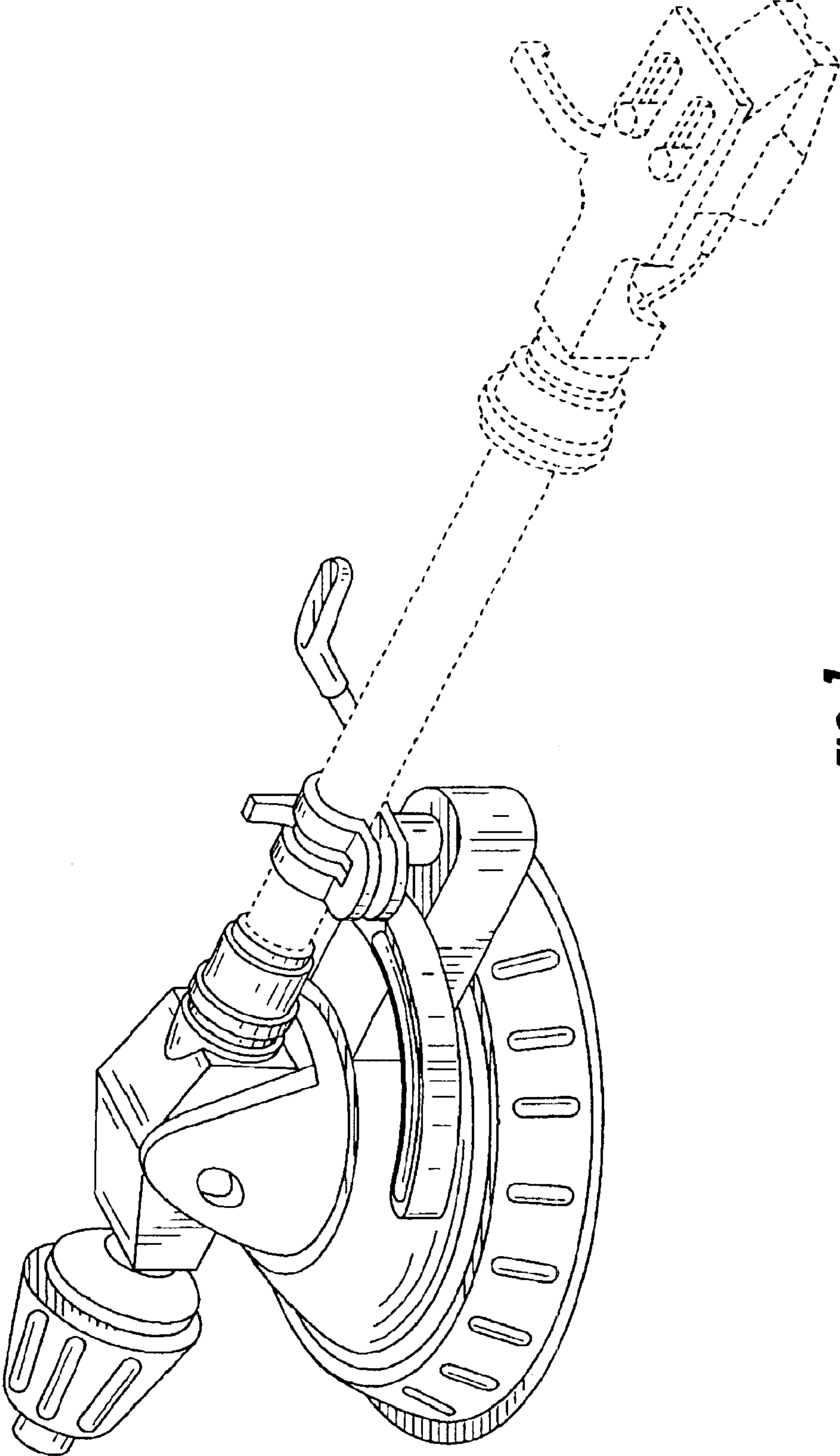

FIG. 1.

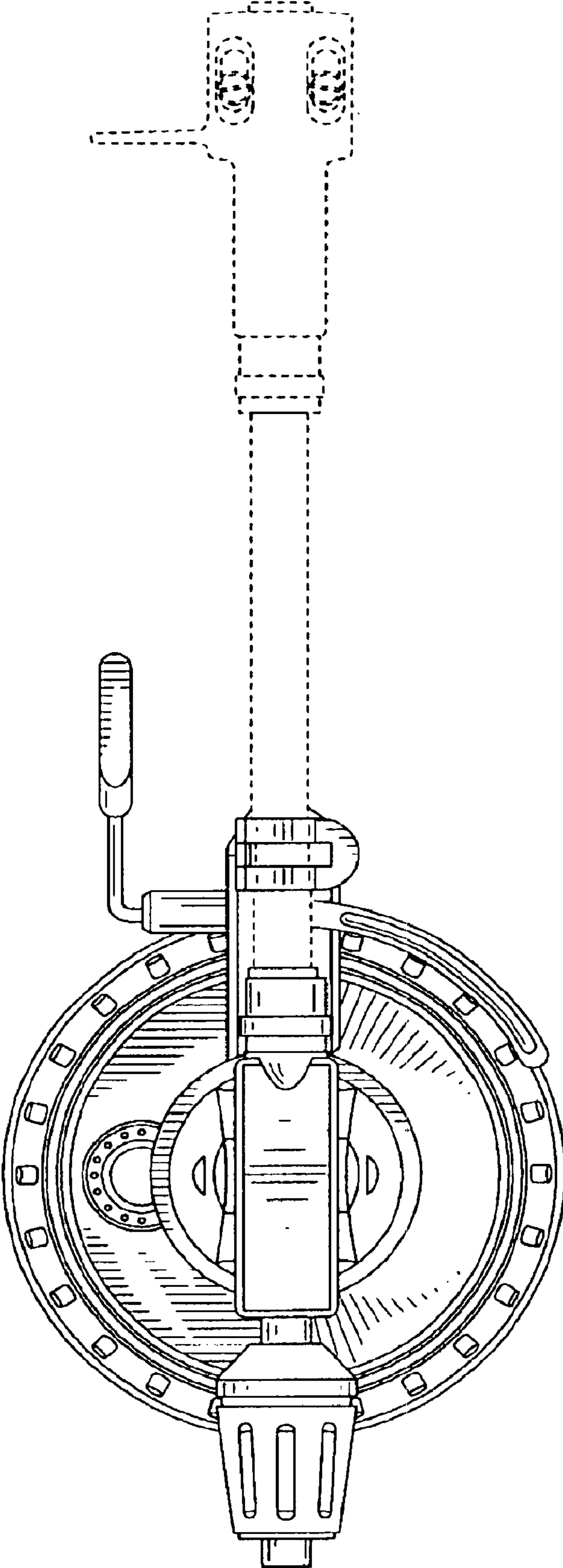

FIG. 2.

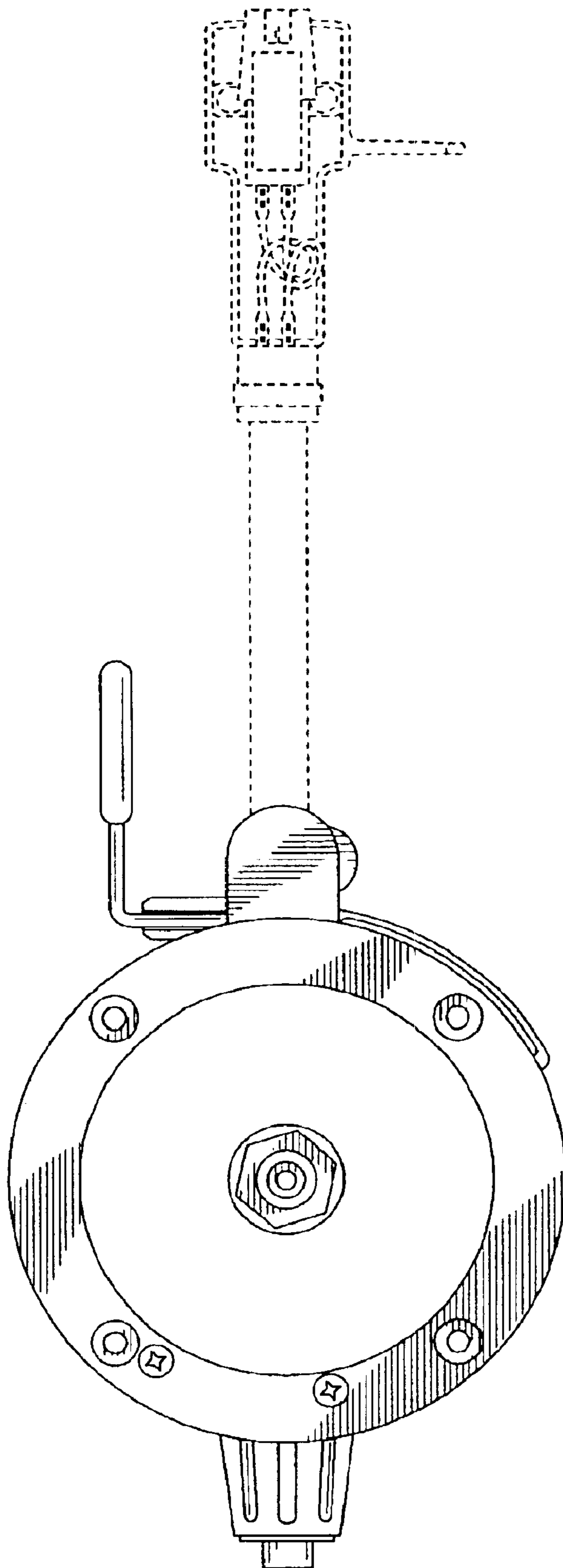

FIG. 3.

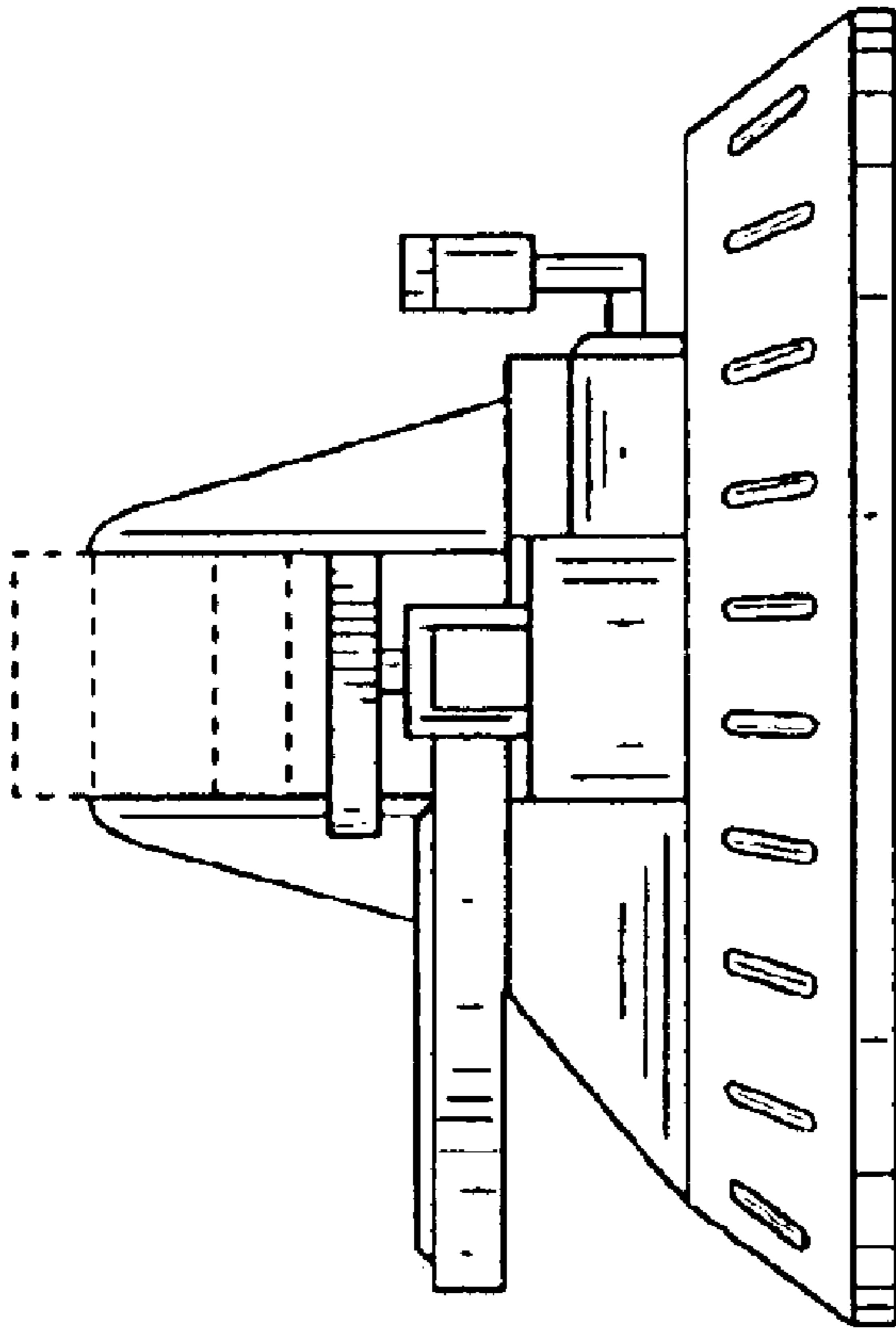

FIG. 4.

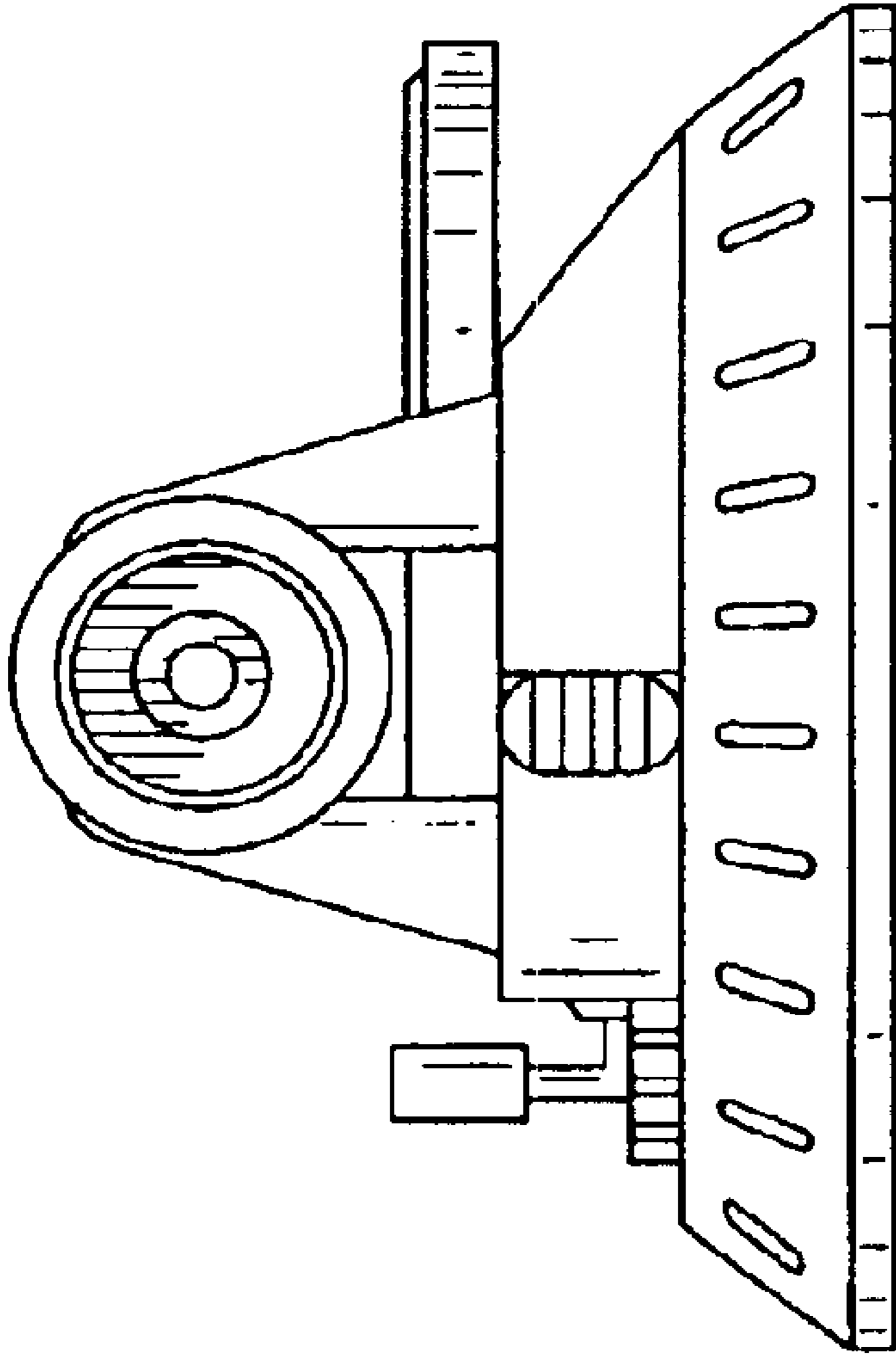

FIG. 5.

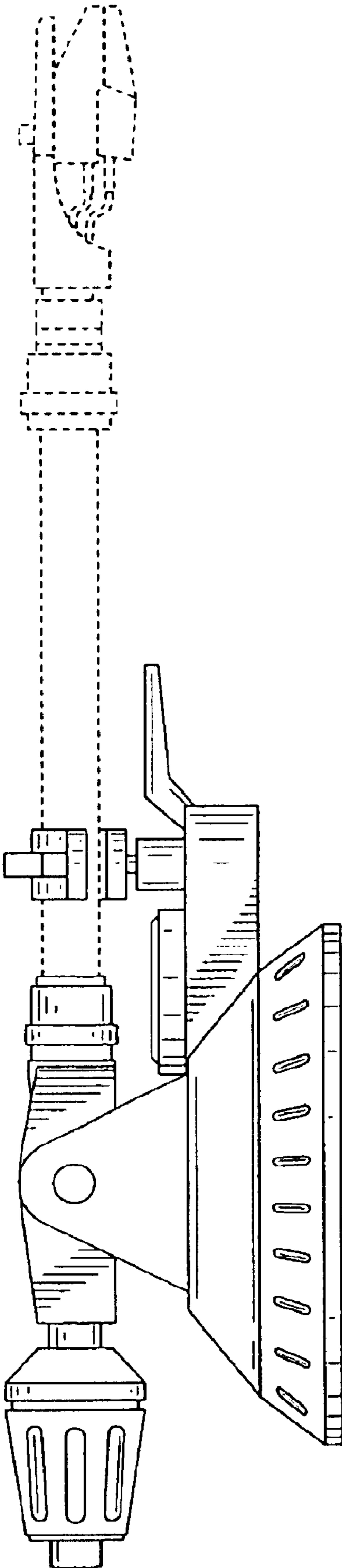

FIG. 6.

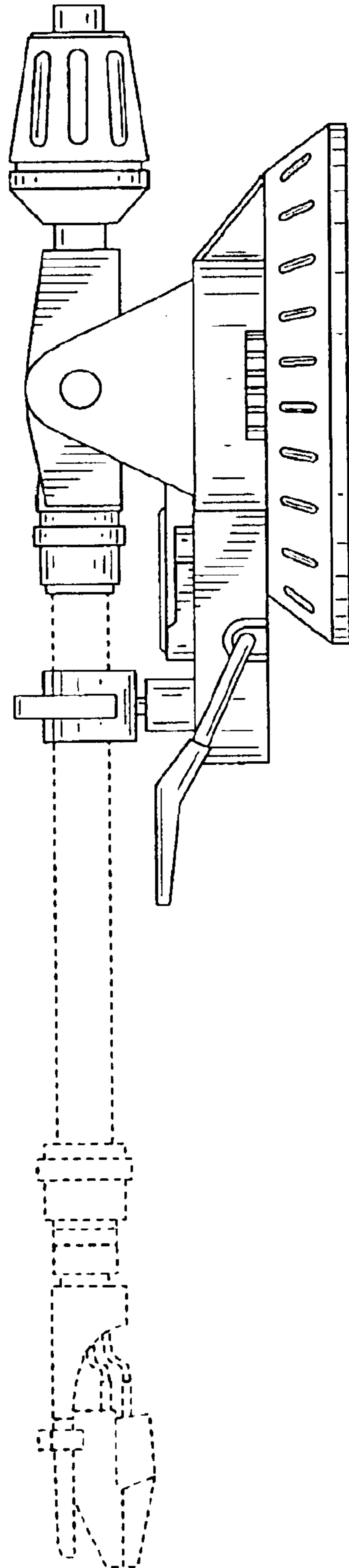

FIG. 7.