

US00D494127S1

(12) **United States Design Patent** (10) **Patent No.:** **US D494,127 S**
Eatkins et al. (45) **Date of Patent:** **** Aug. 10, 2004**

(54) **WING CONFIGURATION FOR A JET AIRPLANE**

(75) Inventors: **Mark Eatkins**, Kirkland, WA (US);
Paul Dees, Woodinville, WA (US);
Blake Emery, Enumclaw, WA (US);
Chris B. Kettering, Kirkland, WA (US);
Kevin Retz, Bothell, WA (US);
Paul Mikulencak, Everett, WA (US)

(73) Assignee: **The Boeing Company**, Chicago, IL (US)

(**) Term: **14 Years**

(21) Appl. No.: **29/187,437**

(22) Filed: **Aug. 1, 2003**

Related U.S. Application Data

(62) Division of application No. 29/181,153, filed on May 5, 2003.

(51) **LOC (7) Cl.** **12-99**

(52) **U.S. Cl.** **D12/319**

(58) **Field of Search** D12/319-345;
244/45 A, 45 R, 13, 15, 91, 198, 211, 218

(56) **References Cited**

U.S. PATENT DOCUMENTS

D354,474 S * 1/1995 Murphy et al. D12/319

D370,456 S * 6/1996 Buchsel et al. D12/319
D397,989 S * 9/1998 Al-Sabah D12/319
D426,804 S * 6/2000 Birrenbach D12/319
D451,879 S * 12/2001 Fraser D12/319

* cited by examiner

Primary Examiner—Marcus A. Jackson

(57) **CLAIM**

The ornamental design for the wing configuration for a jet airplane, as shown and described.

DESCRIPTION

FIG. 1 is a perspective view of the inventive wing configuration for a jet airplane;

FIG. 2 is a top plan view of the wing configuration for a jet airplane;

FIG. 3 is a front end plan view of the wing configuration for a jet airplane;

FIG. 4 is a rear end plan view of the wing configuration for a jet airplane;

FIG. 5 is a side plan view of the wing configuration for a jet airplane, with the opposite side being a mirror image thereof; and,

FIG. 6 is a bottom plan view of the wing configuration for a jet airplane.

Other portions of the jet airplane are shown in hidden lines. These form part of the environment of the present invention but are not part of the claimed invention.

1 Claim, 5 Drawing Sheets

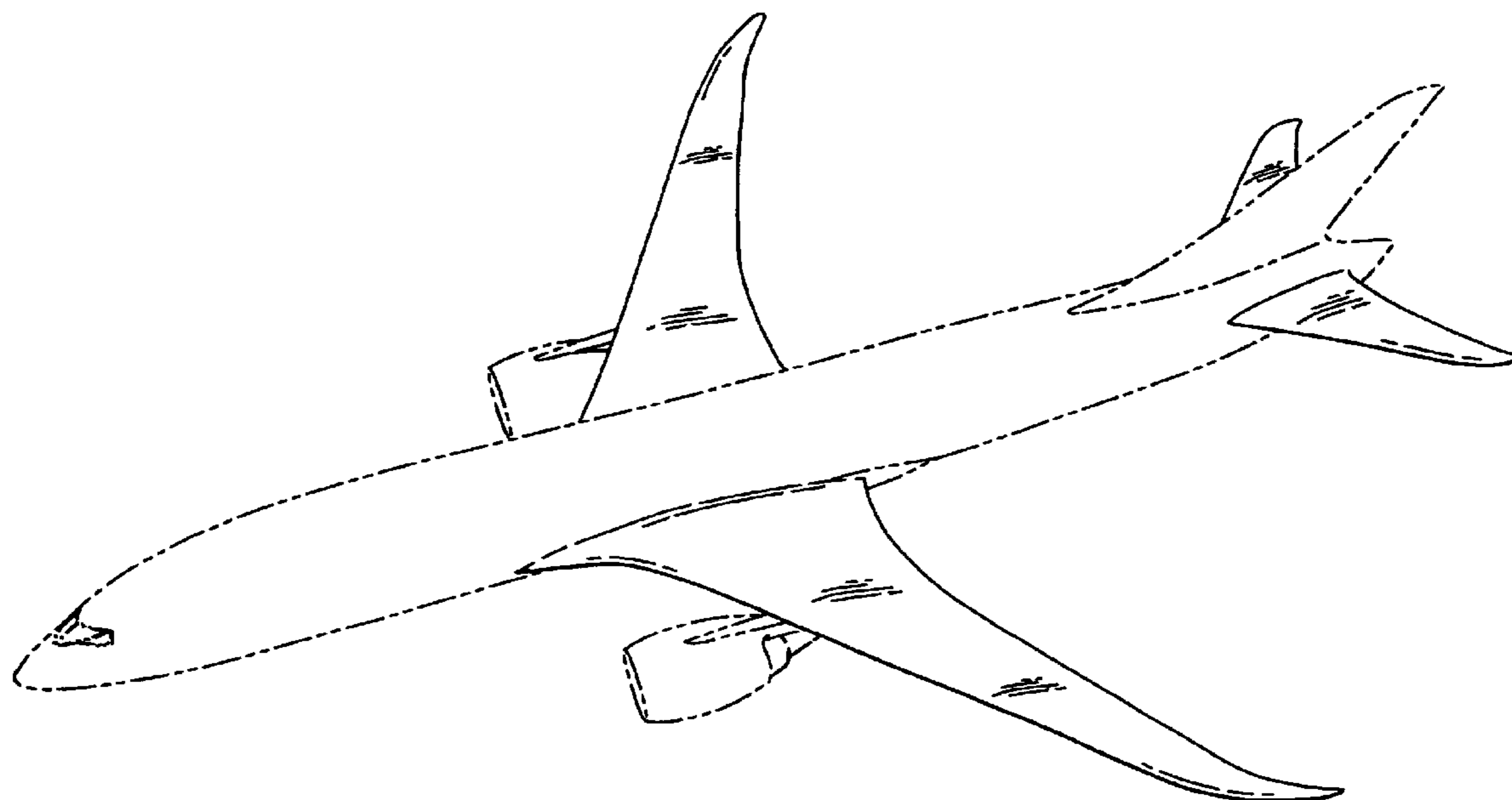

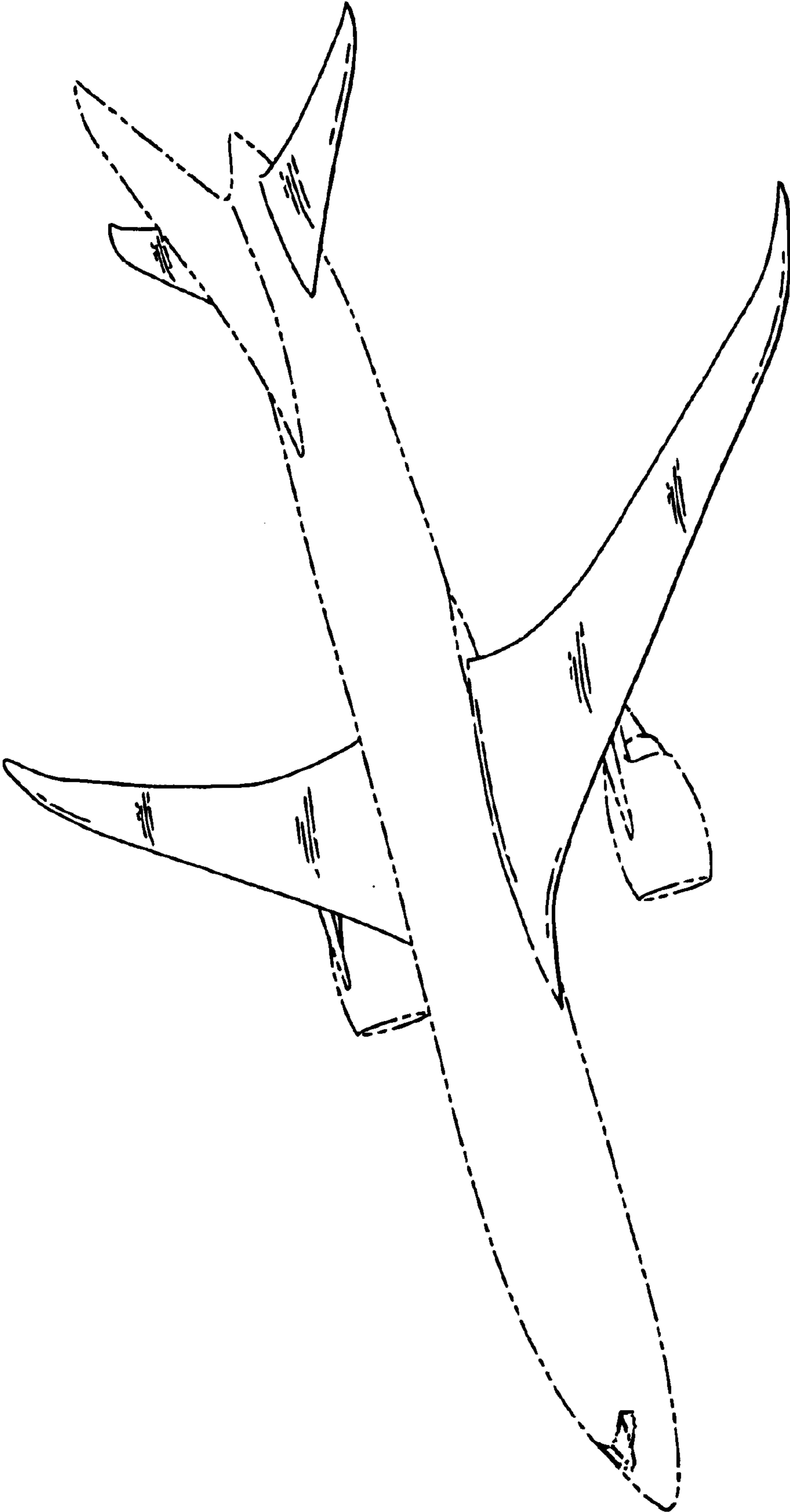

FIG. 1

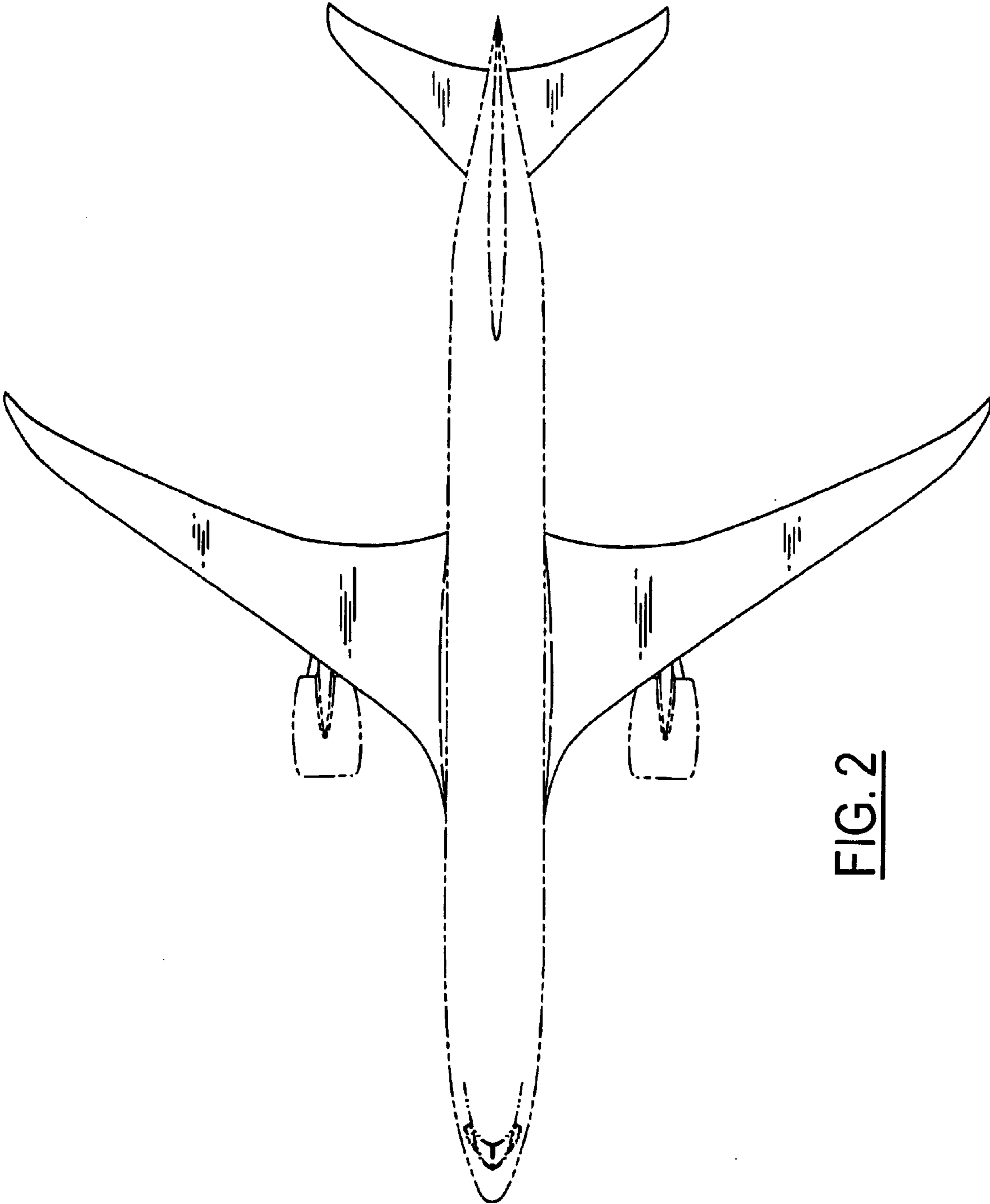

FIG. 2

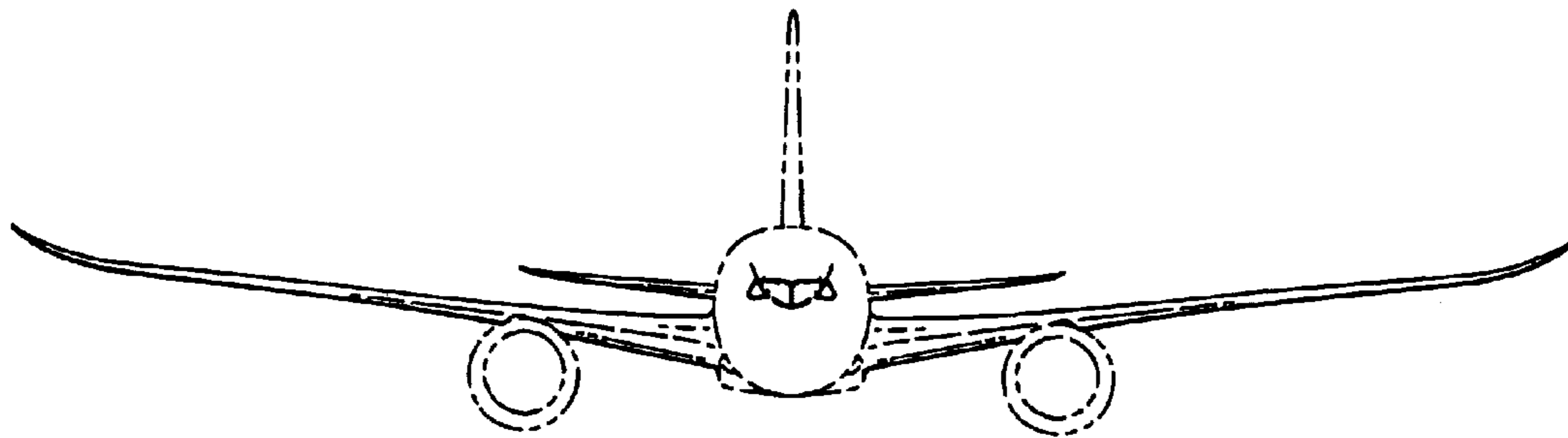

FIG. 3

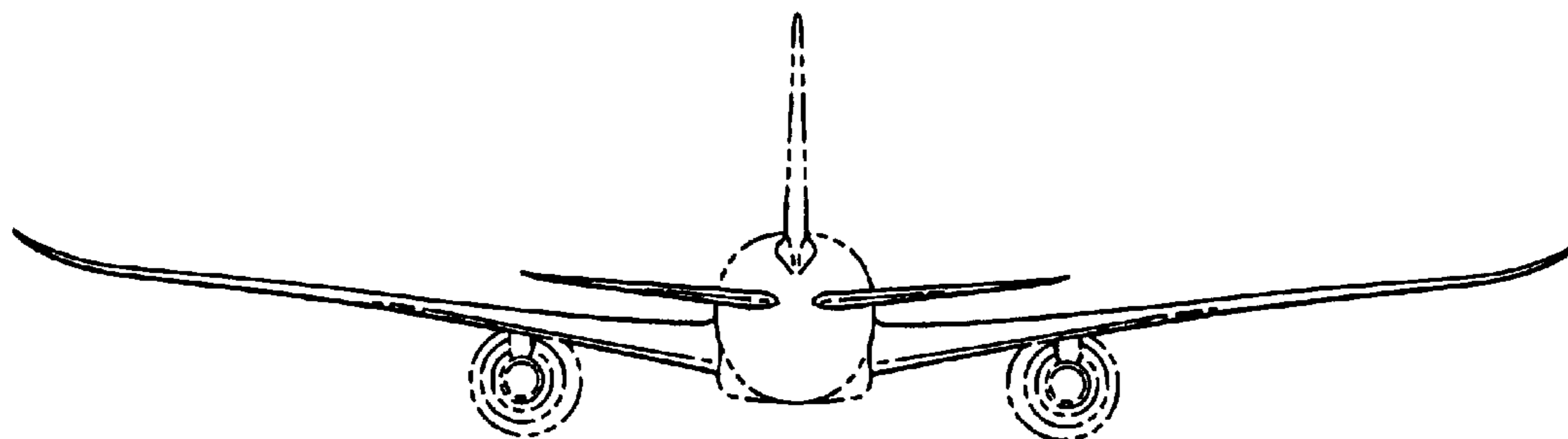

FIG. 4

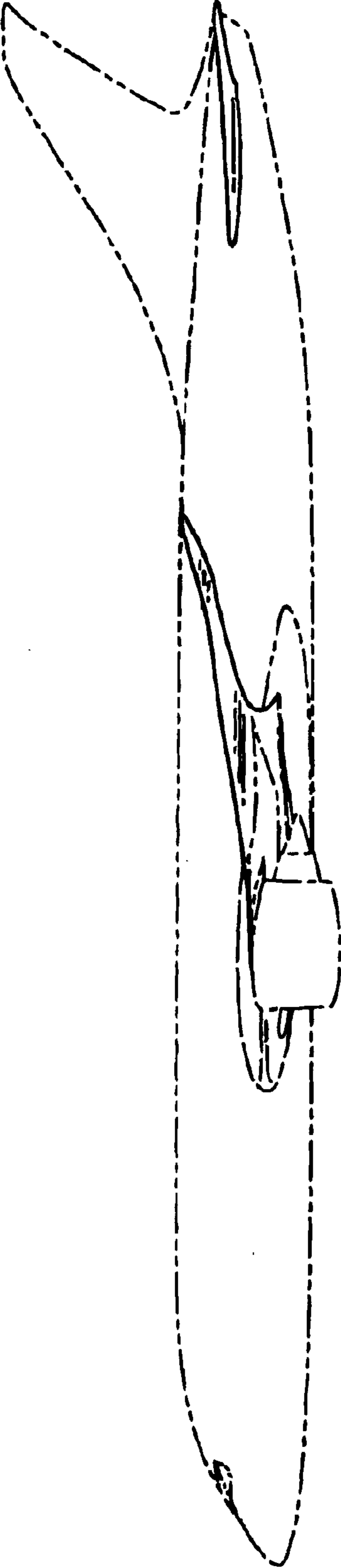

FIG. 5

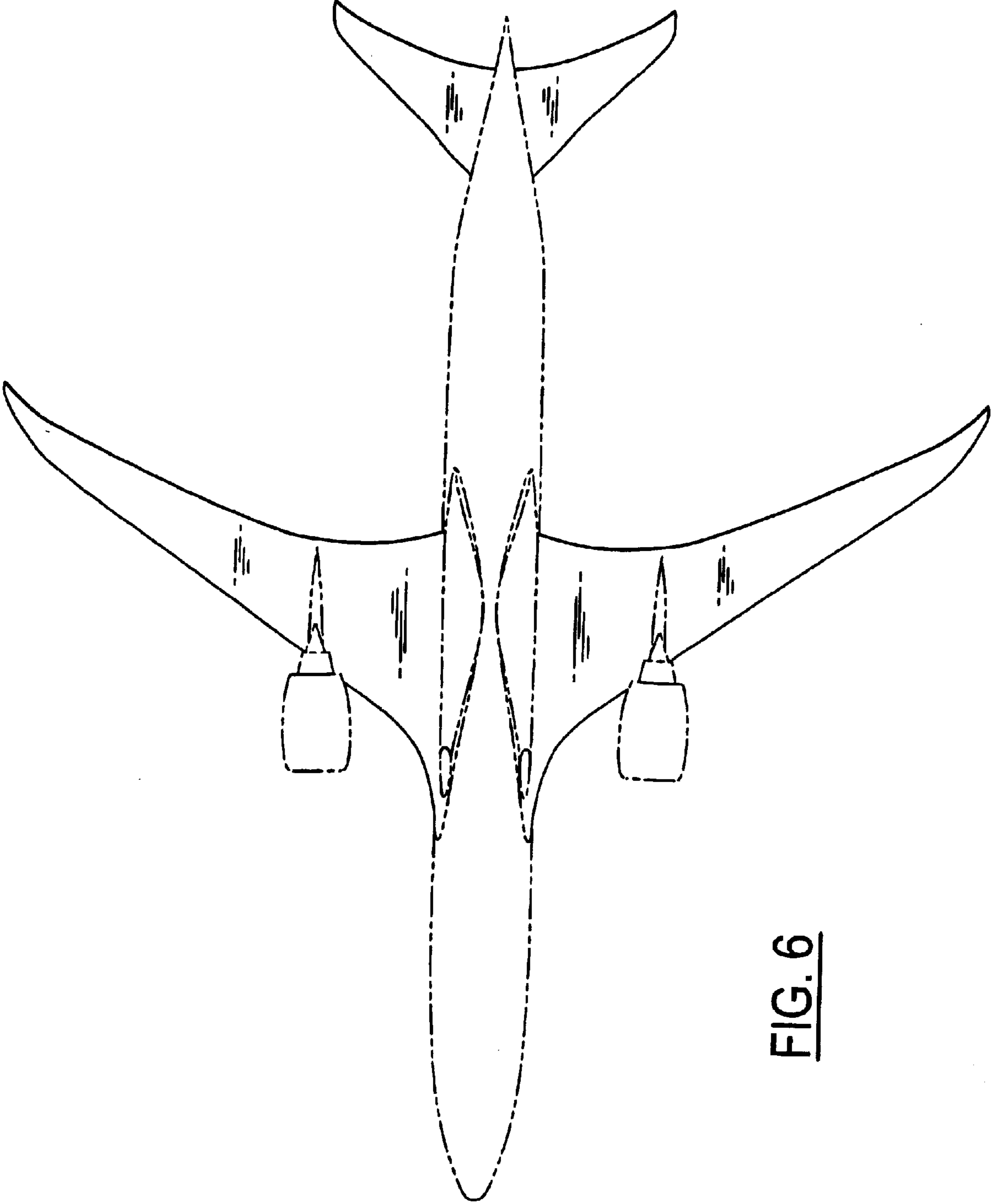

FIG. 6