



US00D493900S1

(12) **United States Design Patent** (10) **Patent No.:** **US D493,900 S**
Jacobs (45) **Date of Patent:** **** Aug. 3, 2004**

(54) **MOTORCYCLE LIGHT**

(75) Inventor: **Christopher G. Jacobs**, Cincinnati, OH (US)

(73) Assignee: **Let's Roll, Inc.**, Cincinnati, OH (US)

(**) Term: **14 Years**

(21) Appl. No.: **29/164,976**

(22) Filed: **Aug. 2, 2002**

(51) **LOC (7) Cl.** **26-06**

(52) **U.S. Cl.** **D26/28**

(58) **Field of Search** D26/28-36; 362/61,
362/80, 81, 82, 83, 83.4, 267, 269, 275,
330-340

(56) **References Cited**

U.S. PATENT DOCUMENTS

D397,475 S	*	8/1998	Jacobs	D26/28
D423,126 S	*	4/2000	Doss	D26/28
D440,675 S	*	4/2001	Okuda	D26/28
D462,467 S		9/2002	Nakazawa et al.	26/28
D471,659 S	*	3/2003	Jacobs	D26/28

* cited by examiner

Primary Examiner—Marcus A. Jackson

(74) *Attorney, Agent, or Firm*—Wood, Herron & Evans, L.L.P.

(57) **CLAIM**

The ornamental design for the motorcycle light, as shown and described.

DESCRIPTION

FIG. 1 is a perspective view of the front, top and right side of a first embodiment of my new motorcycle light design;

FIG. 2 is a front elevational view thereof;
FIG. 3 is a right-side elevational view thereof;
FIG. 4 is a rear elevational view thereof;
FIG. 5 is a left-side elevational view thereof;
FIG. 6 is a top plan view thereof; and
FIG. 7 is a bottom plan view thereof.
FIG. 8 is a perspective view of the front, top and right side of a second embodiment of my new motorcycle light design.
FIG. 9 is a front elevational view thereof;
FIG. 10 is a right-side elevational view thereof;
FIG. 11 is a left-side elevational view thereof;
FIG. 12 is a top plan view thereof; and
FIG. 13 is a bottom plan view thereof.

The rear elevational view thereof is identical to FIG. 5.
FIG. 14 is a perspective view of the front, top and right side of a third embodiment of my new motorcycle light design.
FIG. 15 is a front elevational view thereof;
The right side, left side, and rear elevational views thereof are identical to FIGS. 3, 4, and 5, respectively.
The top and bottom plan views thereof are identical to FIGS. 6 and 7, respectively.

FIG. 16 is a perspective view of the front, top and right side of a fifth embodiment of my new motorcycle light design; and,
FIG. 17 is a front elevational view thereof.
The right side, left side, and rear elevational views thereof are identical to FIGS. 3, 4, and 5, respectively.
The top and bottom plan views thereof are identical to FIGS. 6 and 7, respectively.

The broken lines in the figures of the motorcycle light are for illustrative purposes only and form no part of the claimed design.

1 Claim, 5 Drawing Sheets

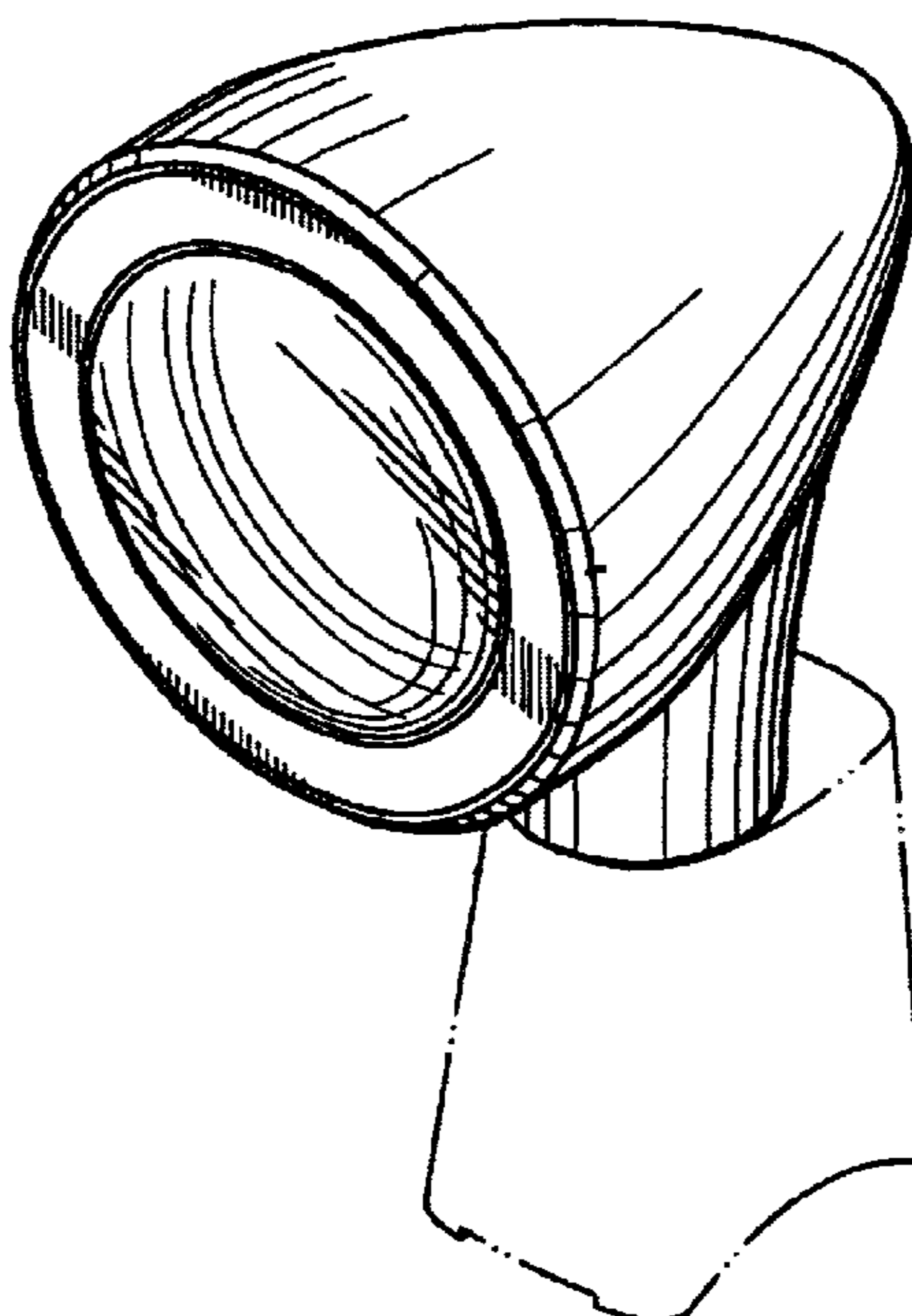

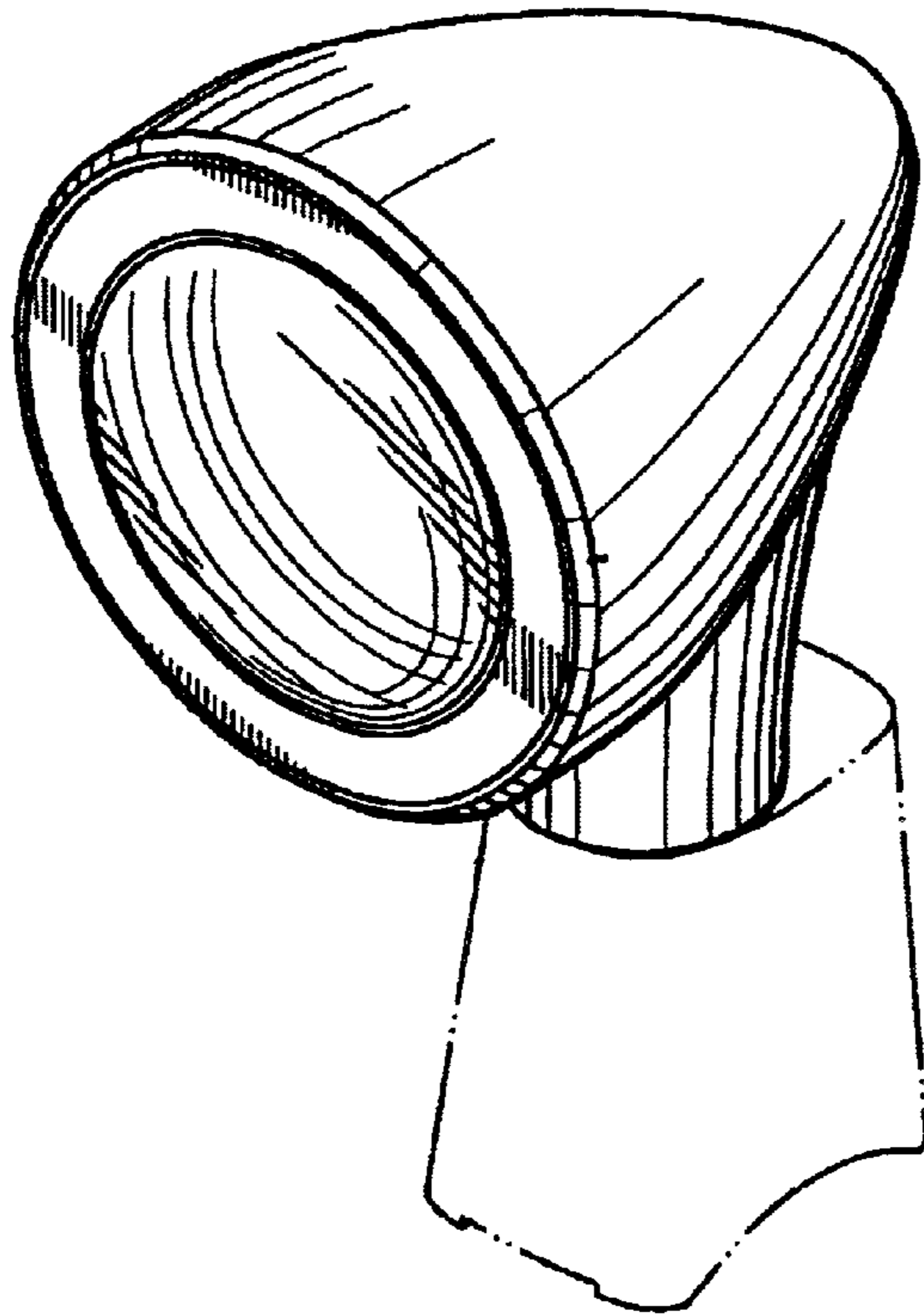

FIG. 1

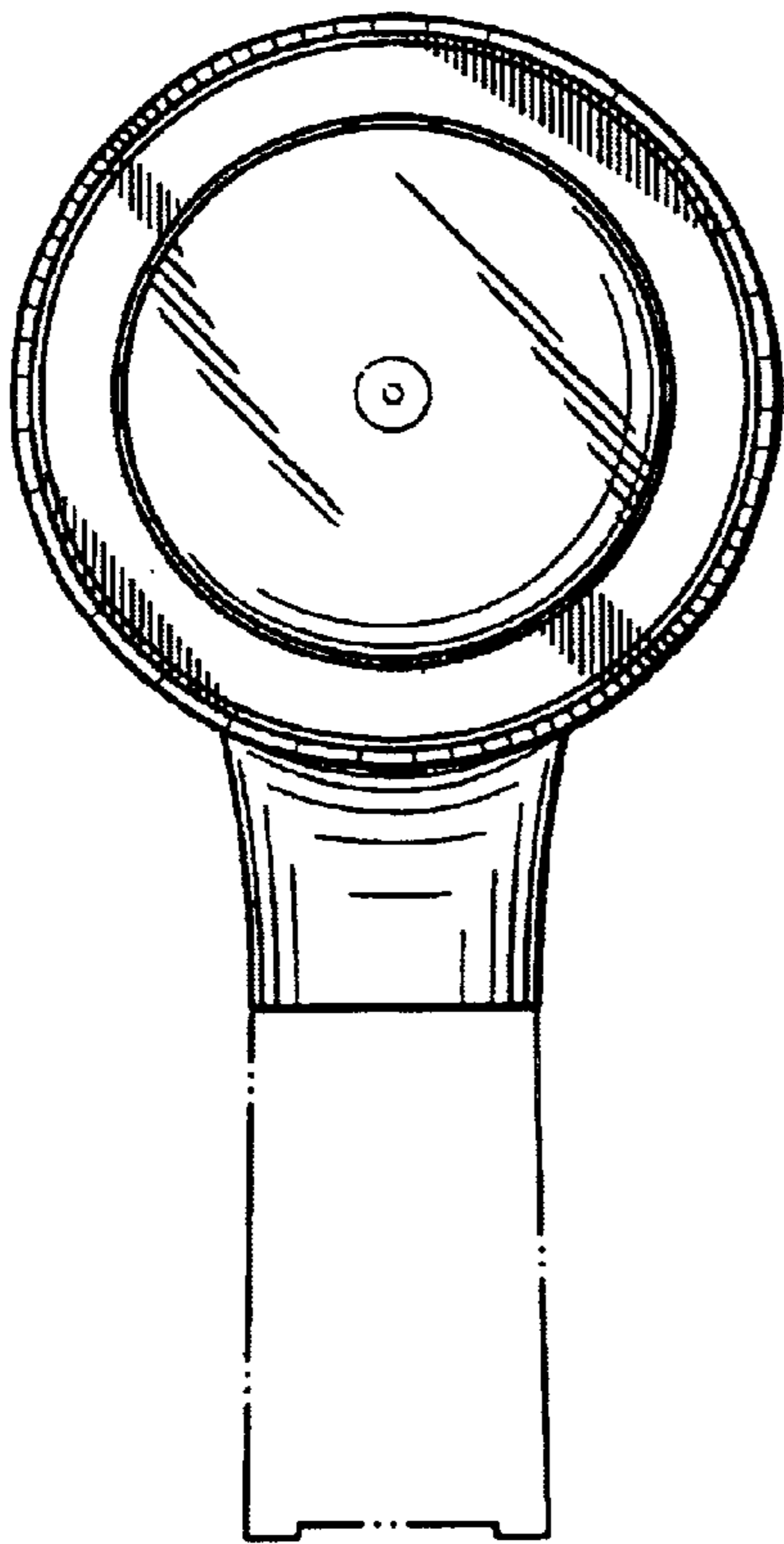

FIG. 2

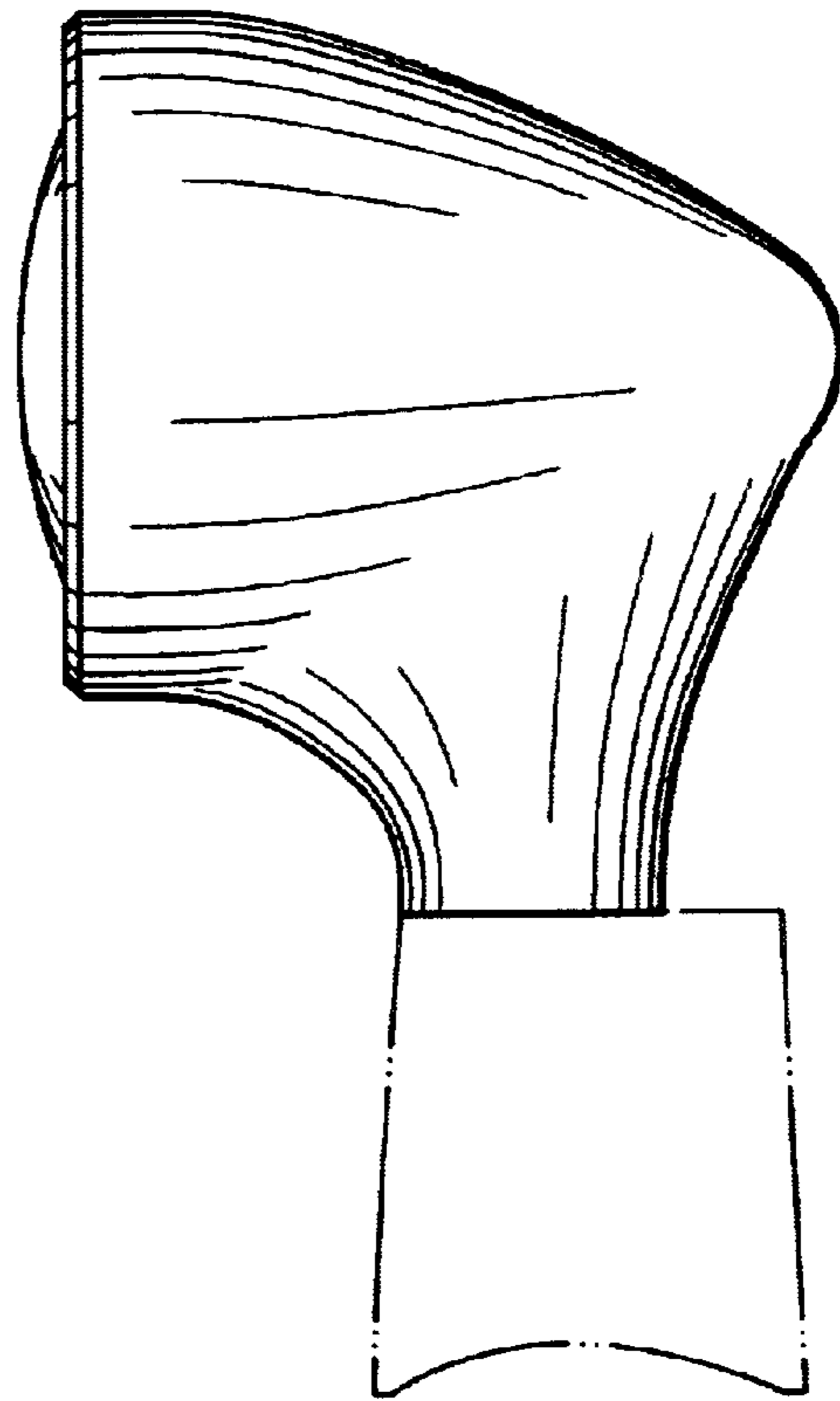

FIG. 3

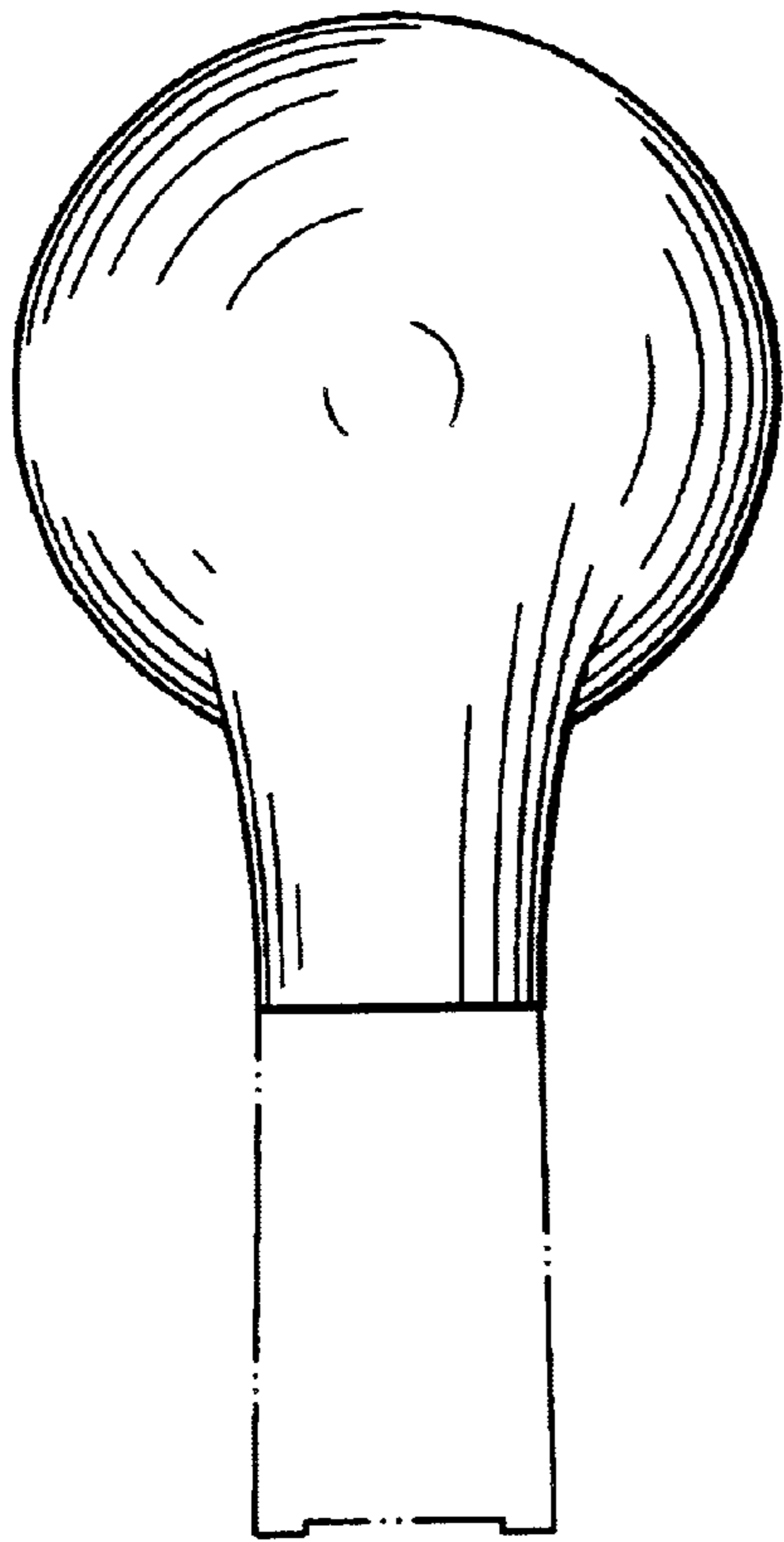

FIG. 4

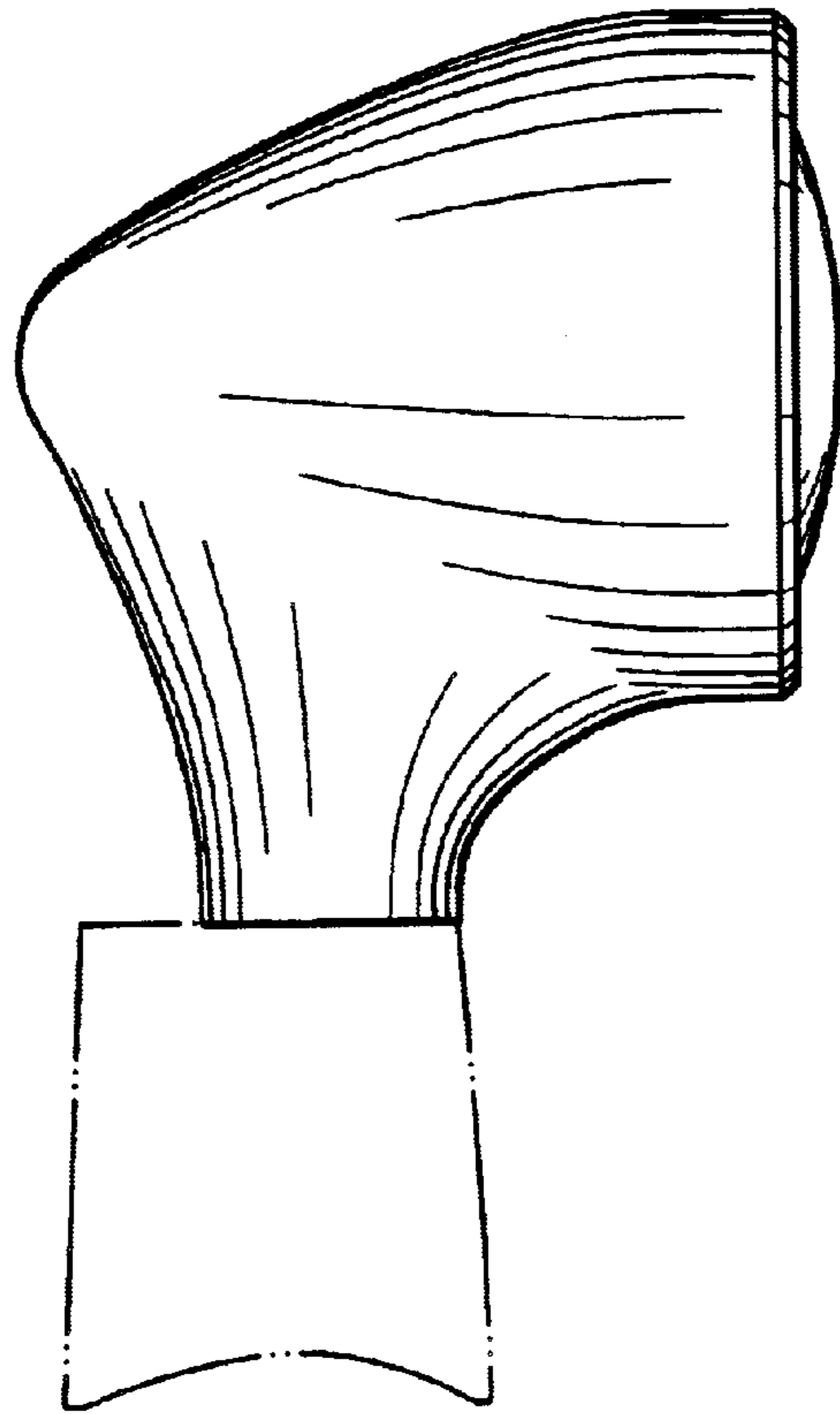

FIG. 5

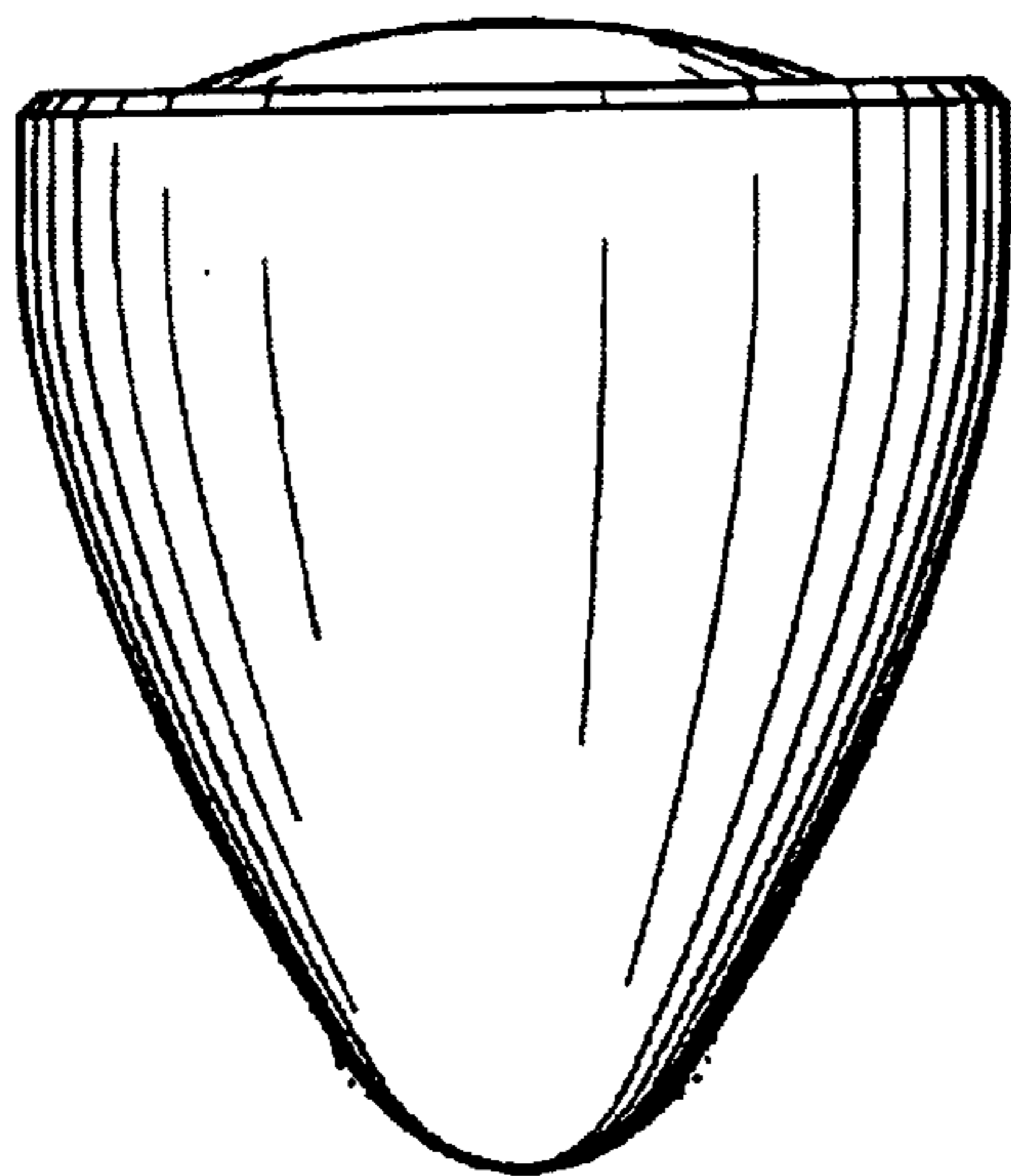

FIG. 6

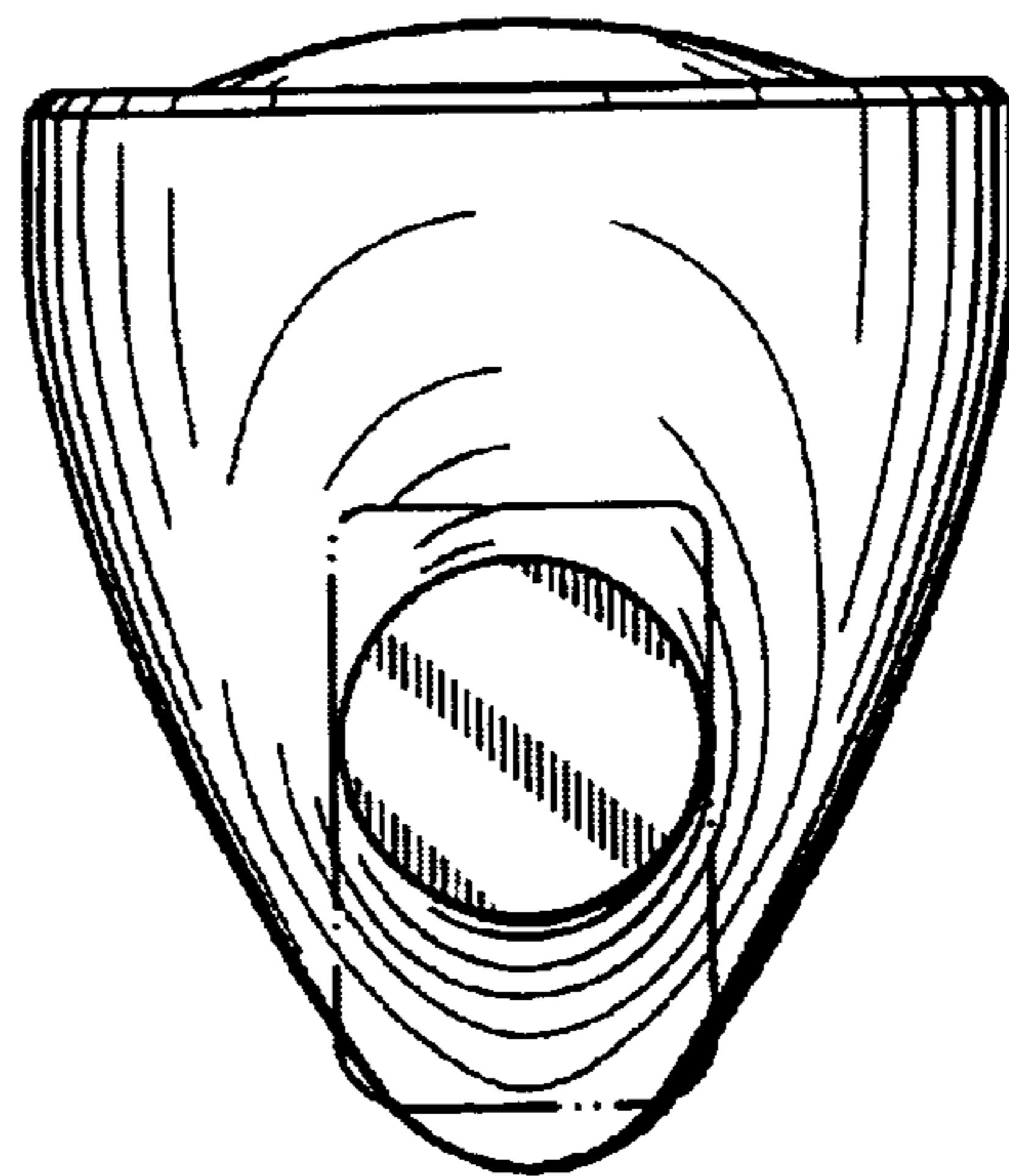

FIG. 7

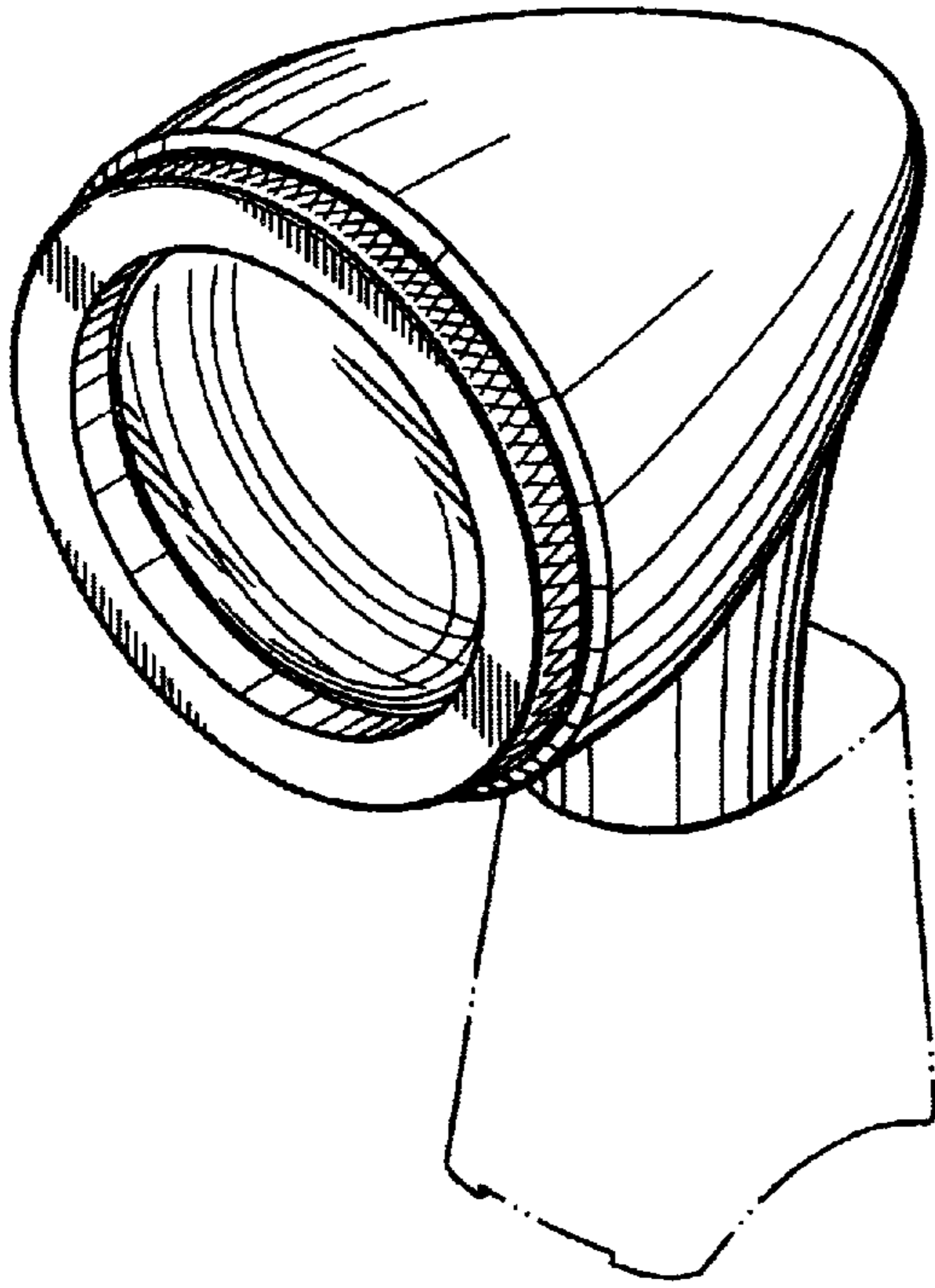

FIG. 8

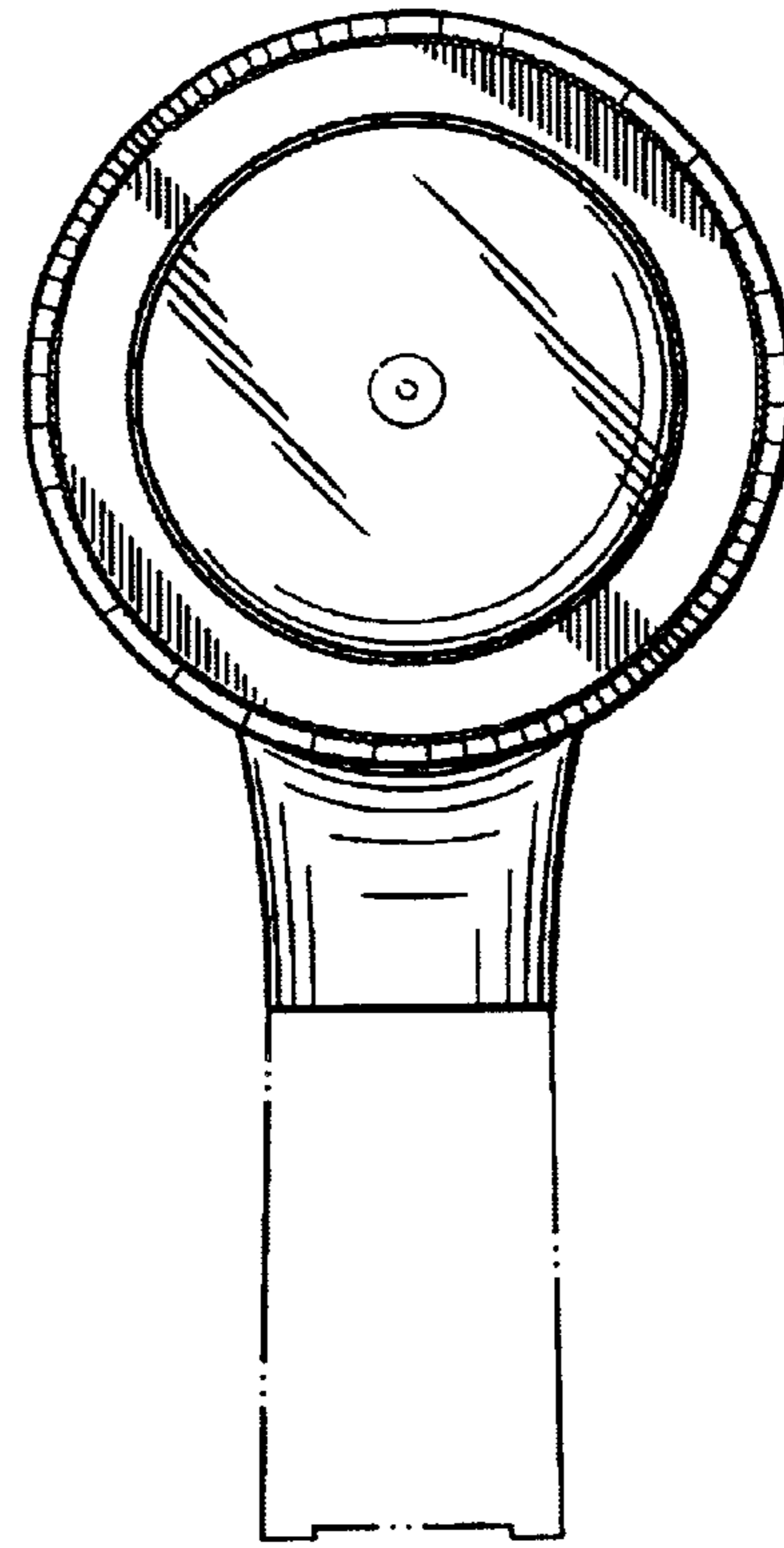

FIG. 9

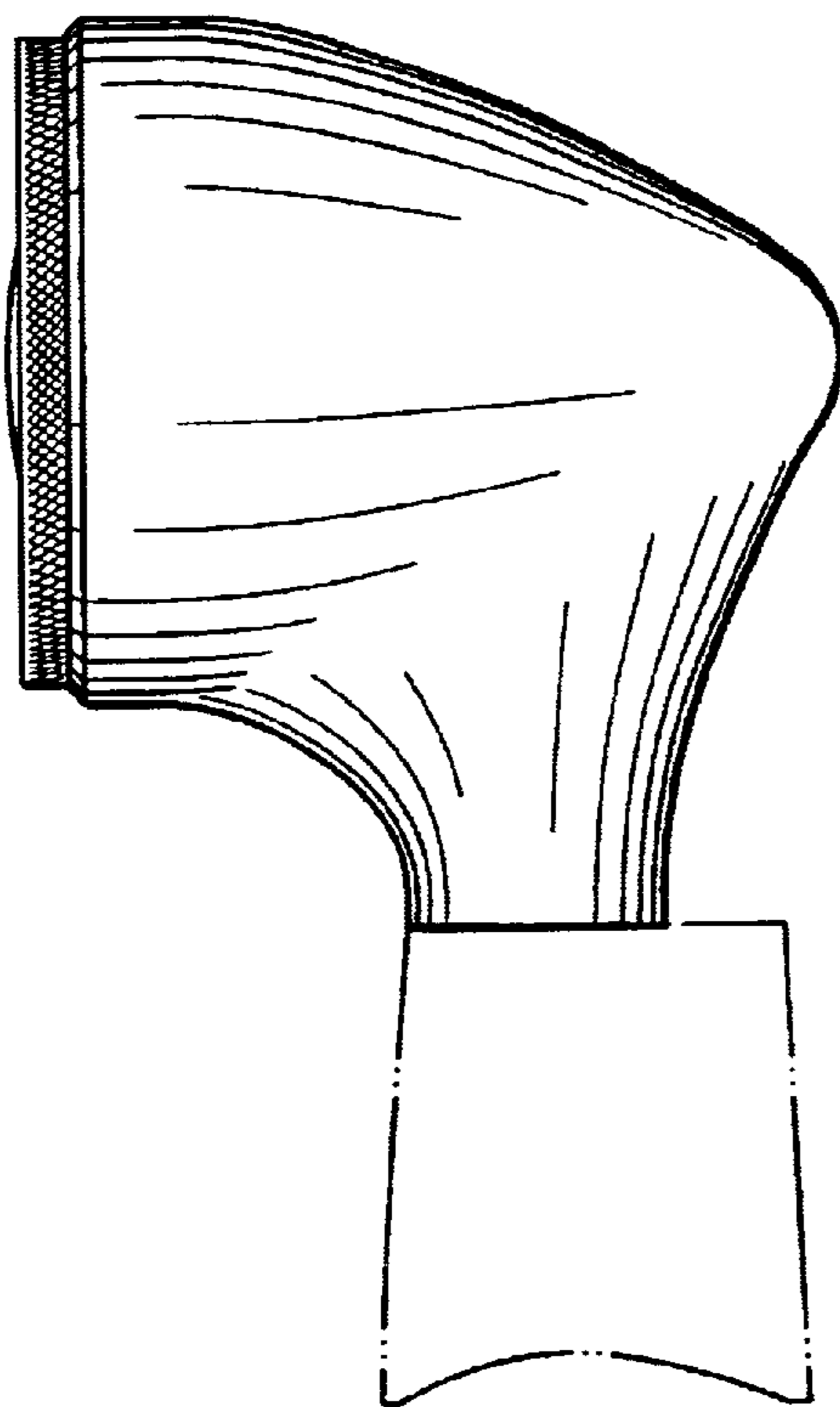

FIG. 10

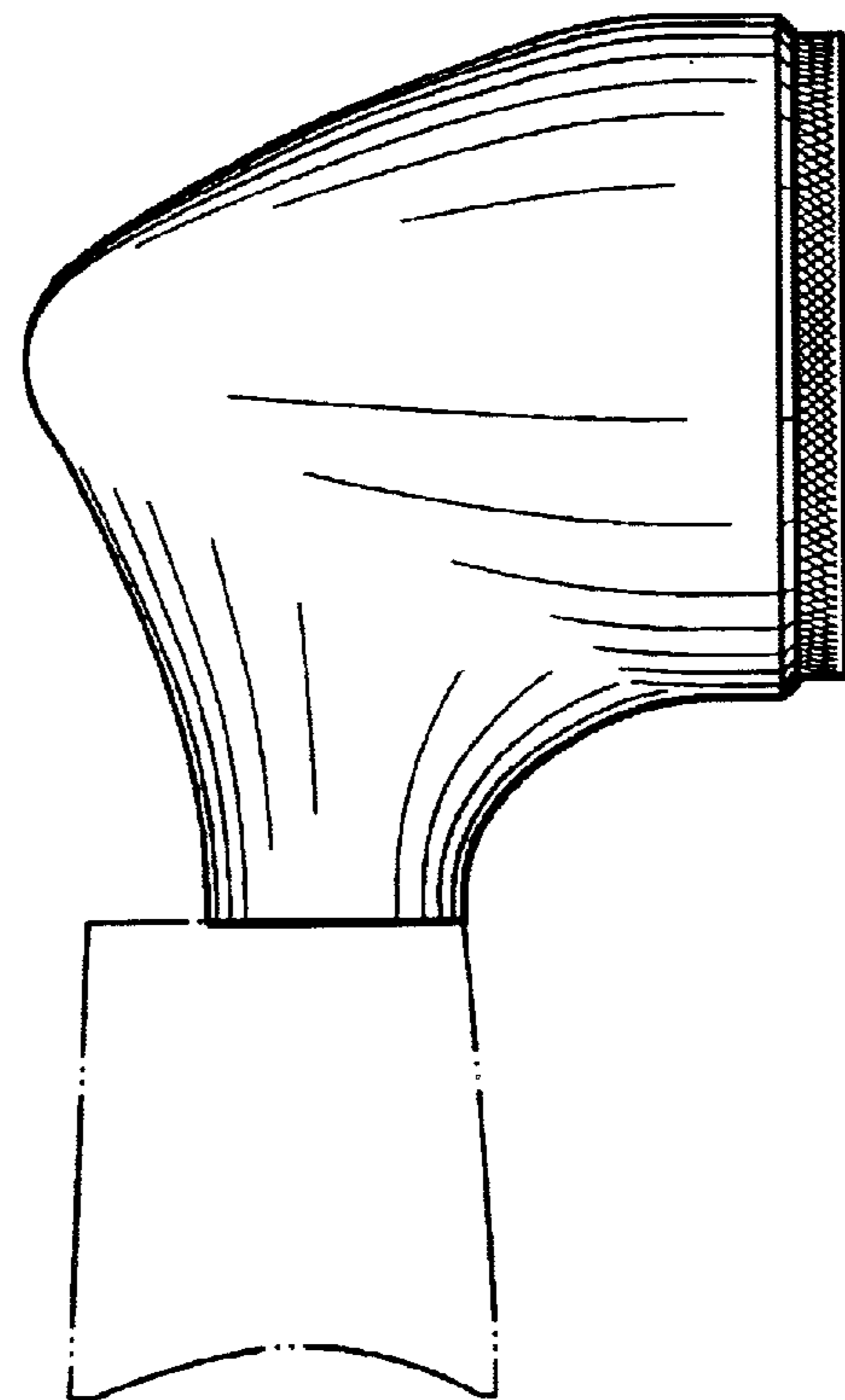

FIG. 11

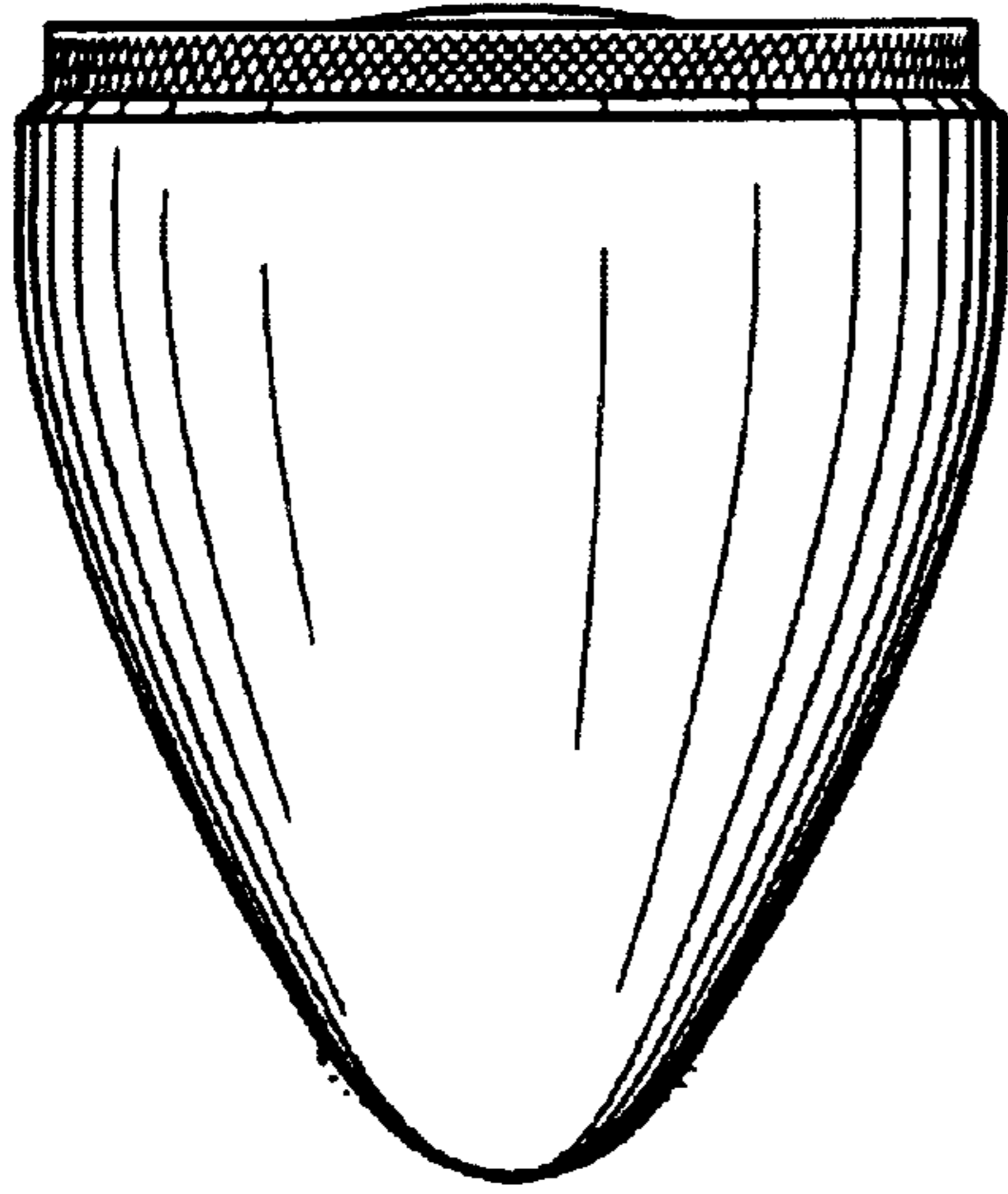

FIG. 12

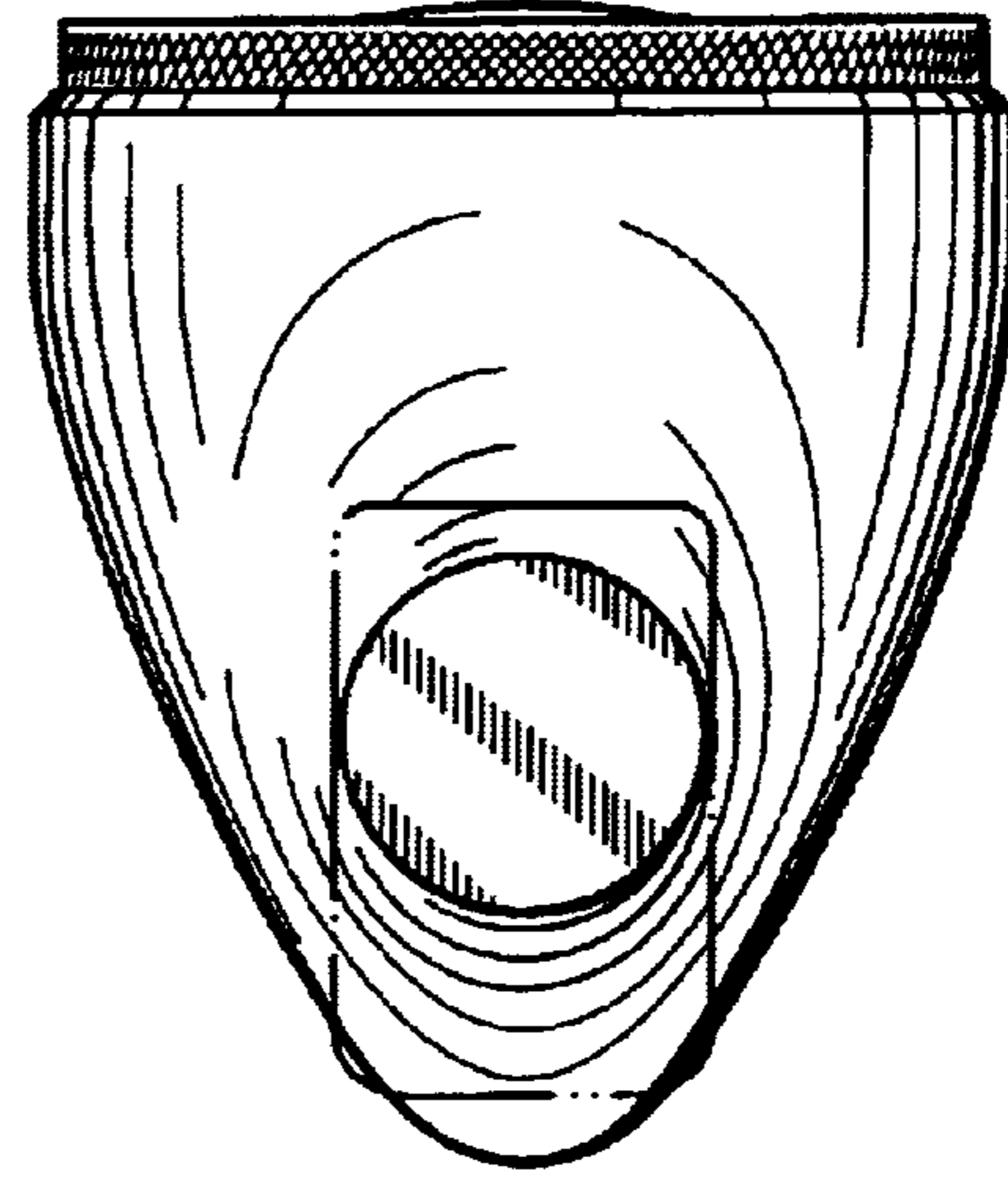

FIG. 13

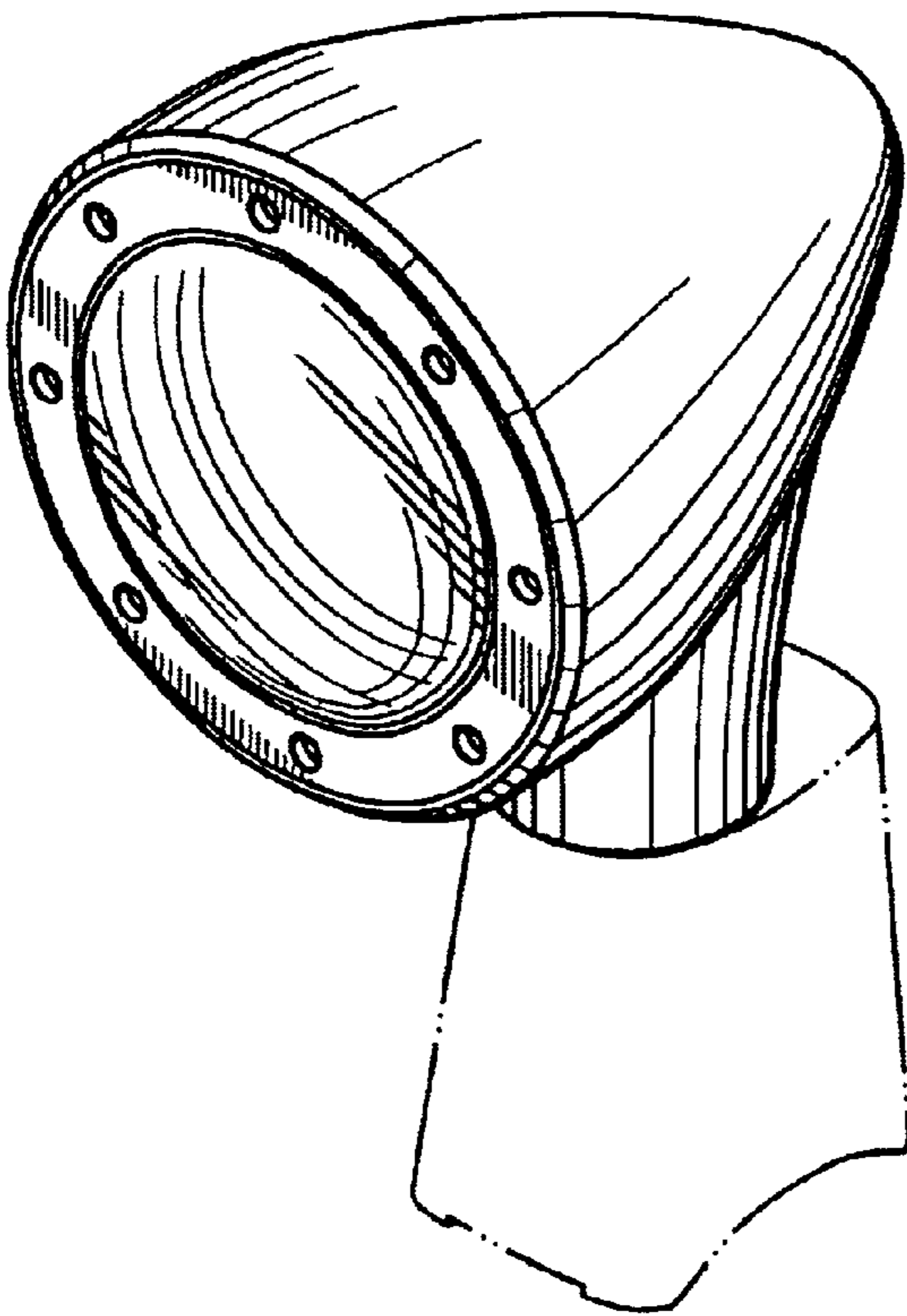

FIG. 14

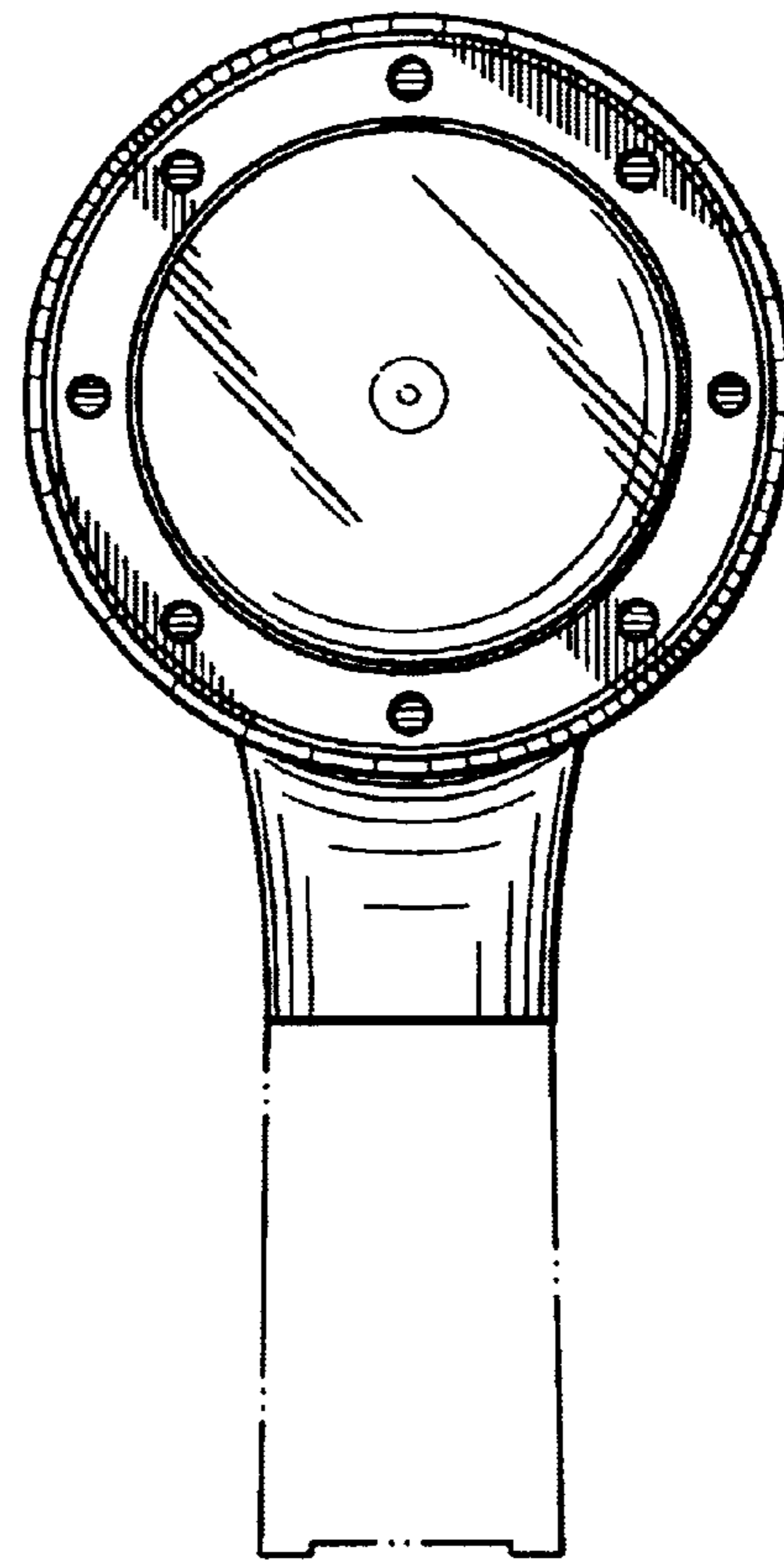

FIG. 15

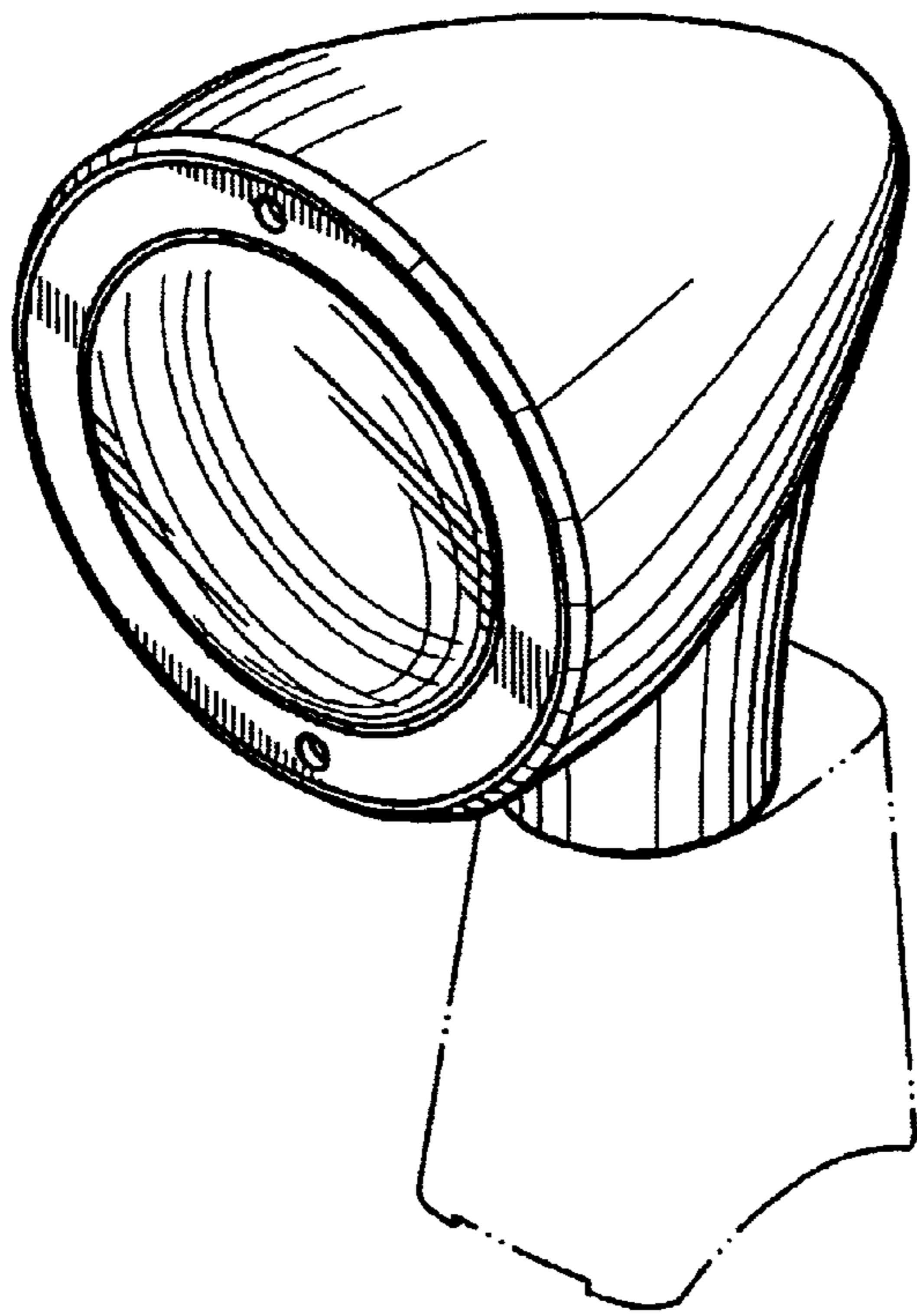

FIG. 16

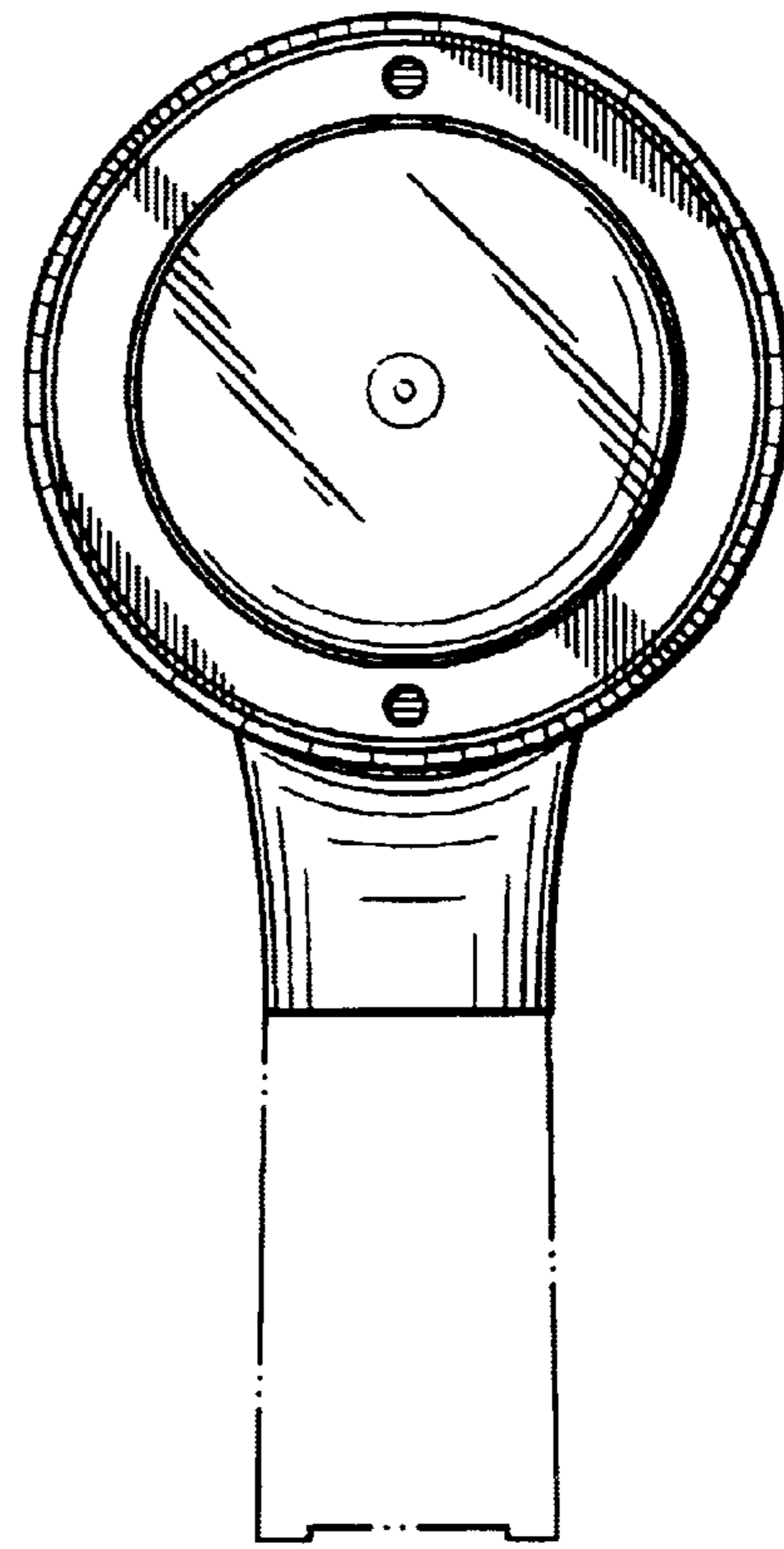

FIG. 17

UNITED STATES PATENT AND TRADEMARK OFFICE
CERTIFICATE OF CORRECTION

PATENT NO. : Des. 493,900 S
APPLICATION NO. : 29/164976
DATED : August 3, 2004
INVENTOR(S) : Christopher G. Jacobs et al.

Page 1 of 1

It is certified that error appears in the above-identified patent and that said Letters Patent is hereby corrected as shown below:

Title Page -

Item [75] Inventors, please add the following inventor and address:

-- **Lawrence Hatfield, Jr.**, Butler, KY (US) --;

In the Description -

Column 1, line 35, delete "my" and substitute therefor -- our --.

Column 2, line 8, delete "my" and substitute therefor -- our --;

line 16, delete "my" and substitute therefor -- our --;

line 23, delete "fifth" and substitute therefor -- fourth --; and delete
"my" and substitute therefor -- our --.

Signed and Sealed this

Twenty-third Day of December, 2008



JON W. DUDAS
Director of the United States Patent and Trademark Office