

US00D493839S1

(12) **United States Design Patent**
Ritter et al.

(10) **Patent No.:** **US D493,839 S**
(45) **Date of Patent:** **** Aug. 3, 2004**

(54) **NOTE PAD HOLDER**

(76) Inventors: **David Ritter**, 4 Vernon Trail,
Riverwoods, IL (US) 60015; **Mitchell**
Feldman, 2251 Congressional La.,
Riverwoods, IL (US) 60015

(**) Term: **14 Years**

(21) Appl. No.: **29/172,953**

(22) Filed: **Dec. 20, 2002**

(51) **LOC (7) Cl.** **19-02**

(52) **U.S. Cl.** **D19/86; D19/92**

(58) **Field of Search** D19/20–25, 65,
D19/75, 76, 78, 86, 91, 92, 95, 99, 100;
D6/518; 206/215, 555, 557; 281/44, 45;
211/10, 11, 13.1, 126, 13

(56) **References Cited**

U.S. PATENT DOCUMENTS

D117,828 S	*	11/1939	Bowers	D19/78 X
D120,743 S	*	5/1940	Petzold	D19/86 X
D120,744 S	*	5/1940	Petzold	D19/92
D140,308 S	*	2/1945	Beckstrom	D19/92
D142,650 S	*	6/1945	Moglen	D19/92
D157,150 S		2/1950	Hanson		
D172,333 S	*	6/1954	Bresler	D19/92
2,791,447 A	*	5/1957	Bresler	281/45
2,806,715 A		9/1957	Smith		
2,883,792 A		4/1959	Marano		
D256,258 S		8/1980	Varrin		
4,418,333 A		11/1983	Schwarzbach et al.		
D284,677 S		7/1986	Armijo		
D298,953 S		12/1988	Roberts		
D313,046 S	*	12/1990	Colani	D19/78
D324,076 S		2/1992	Freitag		

5,100,178 A	3/1992	MacKelvie
5,143,250 A	9/1992	Freitag
5,174,607 A	12/1992	Hill
5,273,155 A	12/1993	Sala
D349,170 S	7/1994	Lin
D357,938 S	5/1995	Wolff
D357,941 S	5/1995	Davis
5,639,123 A	6/1997	Medley et al.
5,673,942 A	10/1997	Despointes
D387,806 S	12/1997	Carlson et al.
D396,492 S	7/1998	Carlson et al.
D436,377 S	1/2001	Young et al.
6,361,075 B1 *	3/2002	Ritter et al. 281/44

* cited by examiner

Primary Examiner—Martie K. Holtje
(74) *Attorney, Agent, or Firm*—Neal, Gerber & Eisenberg,
LLP

(57) **CLAIM**

The ornamental design for a “note pad holder,” as shown and described.

DESCRIPTION

FIG. 1 is a front elevational view of a note pad holder showing the new design;
FIG. 2 is a rear elevational view thereof;
FIG. 3 is a right side elevational view thereof;
FIG. 4 is a left side elevational view thereof;
FIG. 5 is a bottom plan view thereof;
FIG. 6 is a top plan view thereof; and,
FIG. 7 is a front perspective view thereof.
The elements depicted by means of broken lines have been shown for illustrative purposes only and form no part of the claimed design.

1 Claim, 5 Drawing Sheets

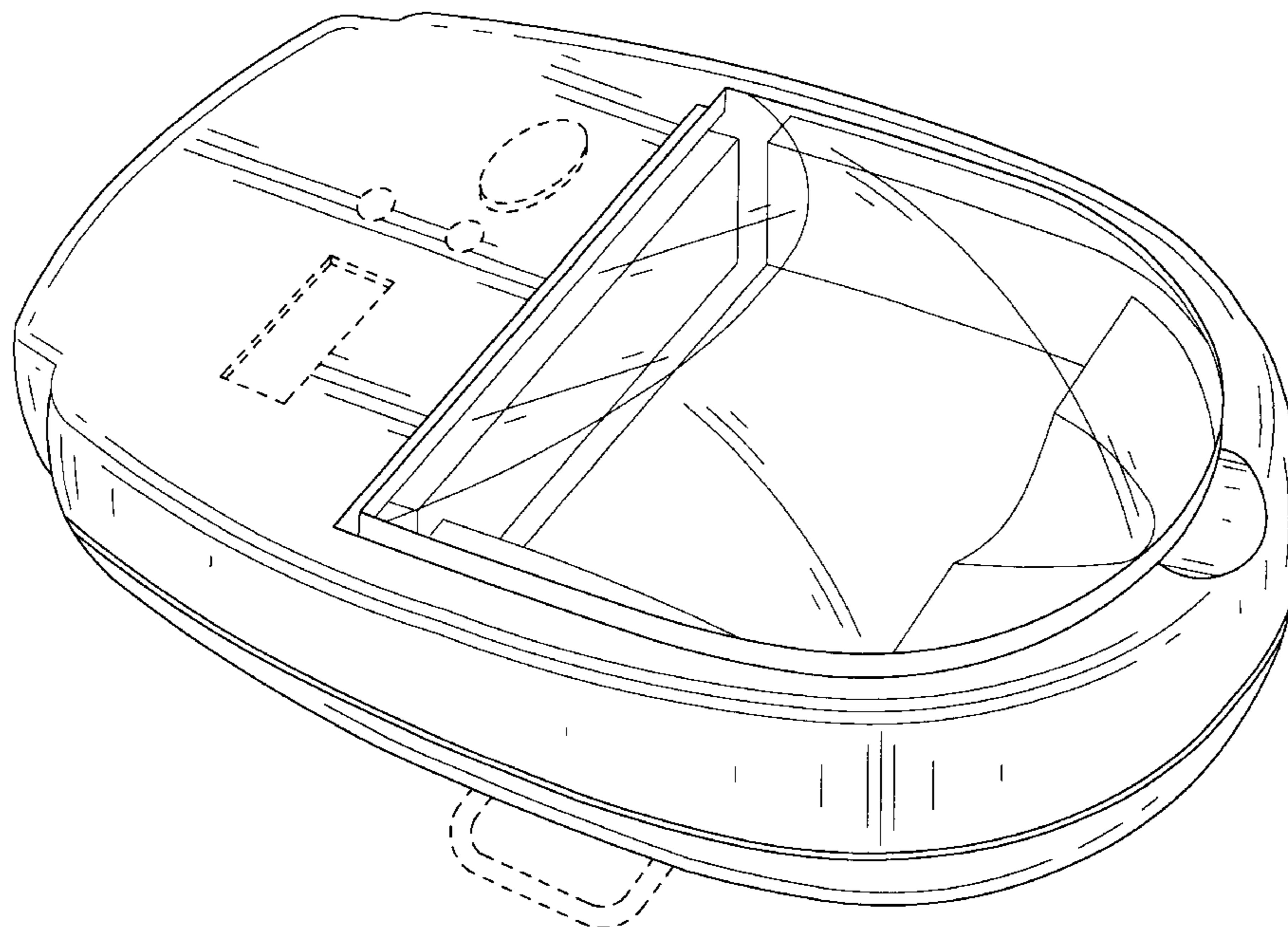

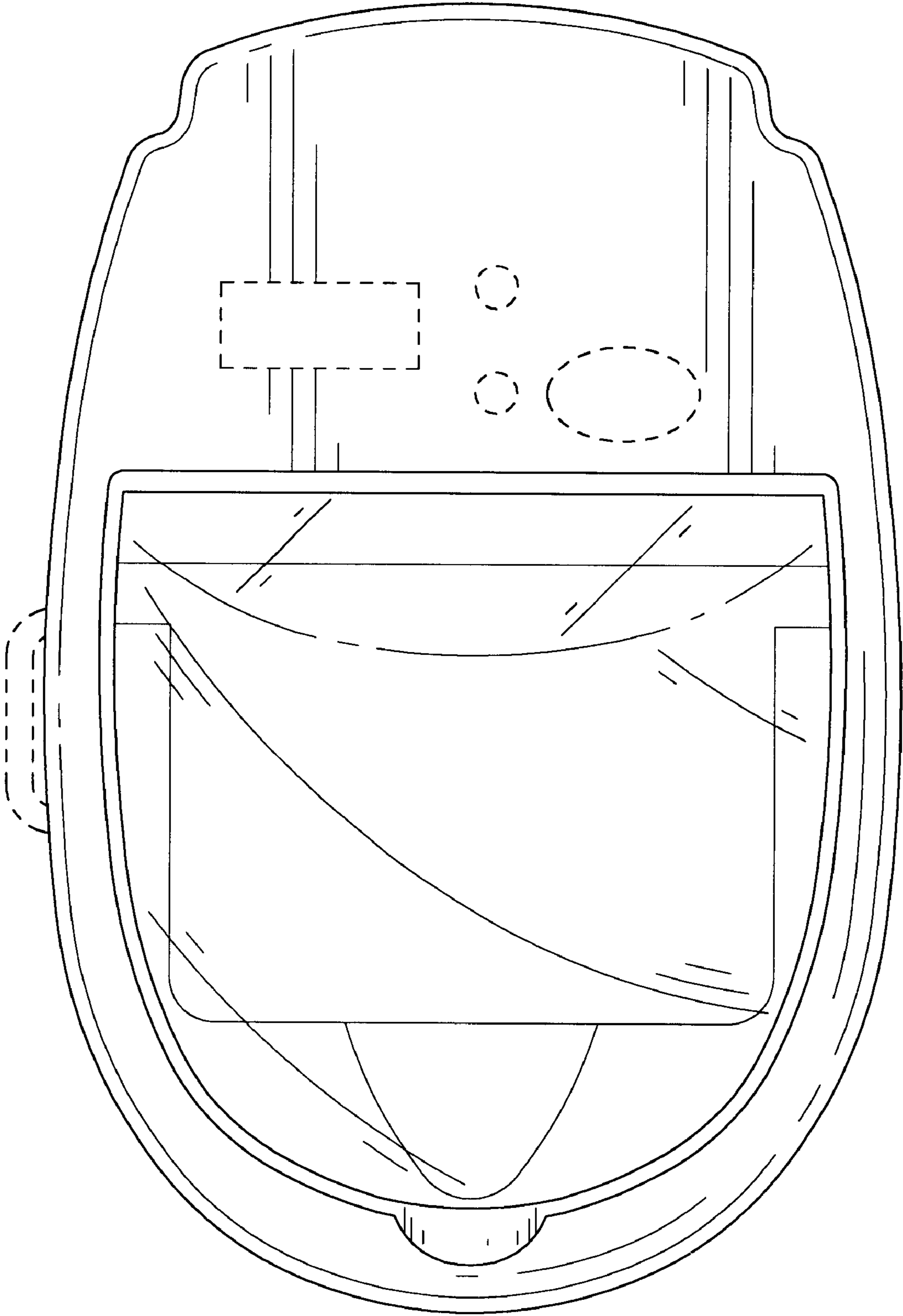

FIG. 1

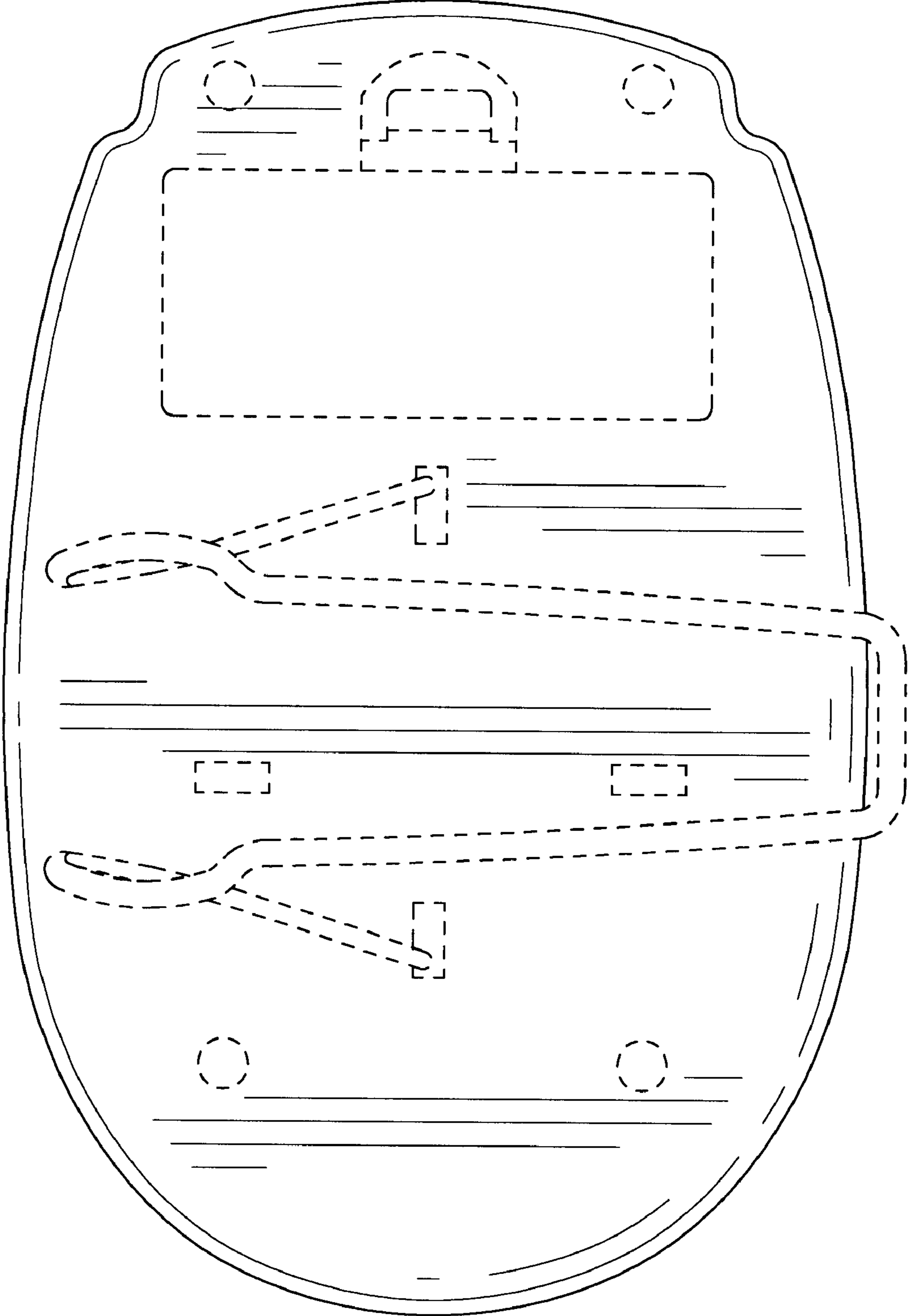

FIG. 2

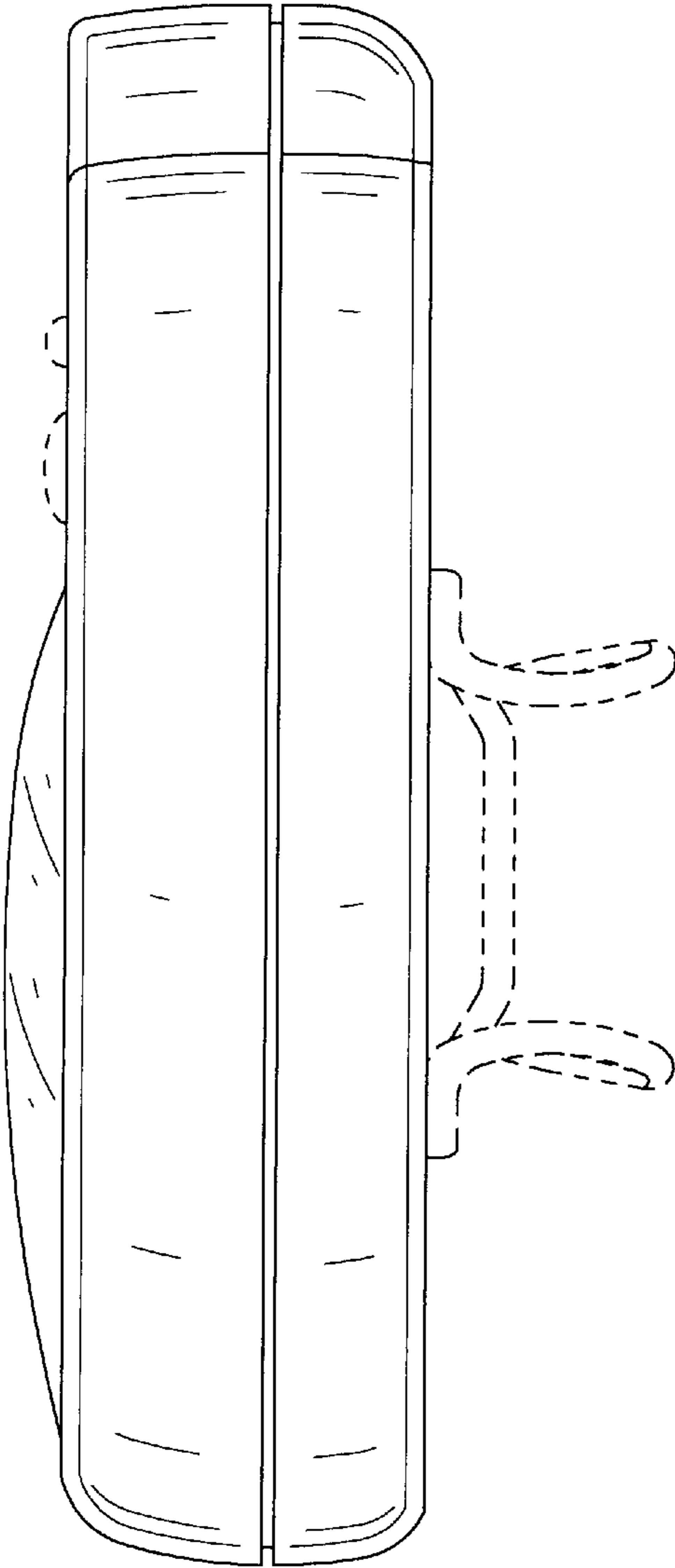

FIG. 3

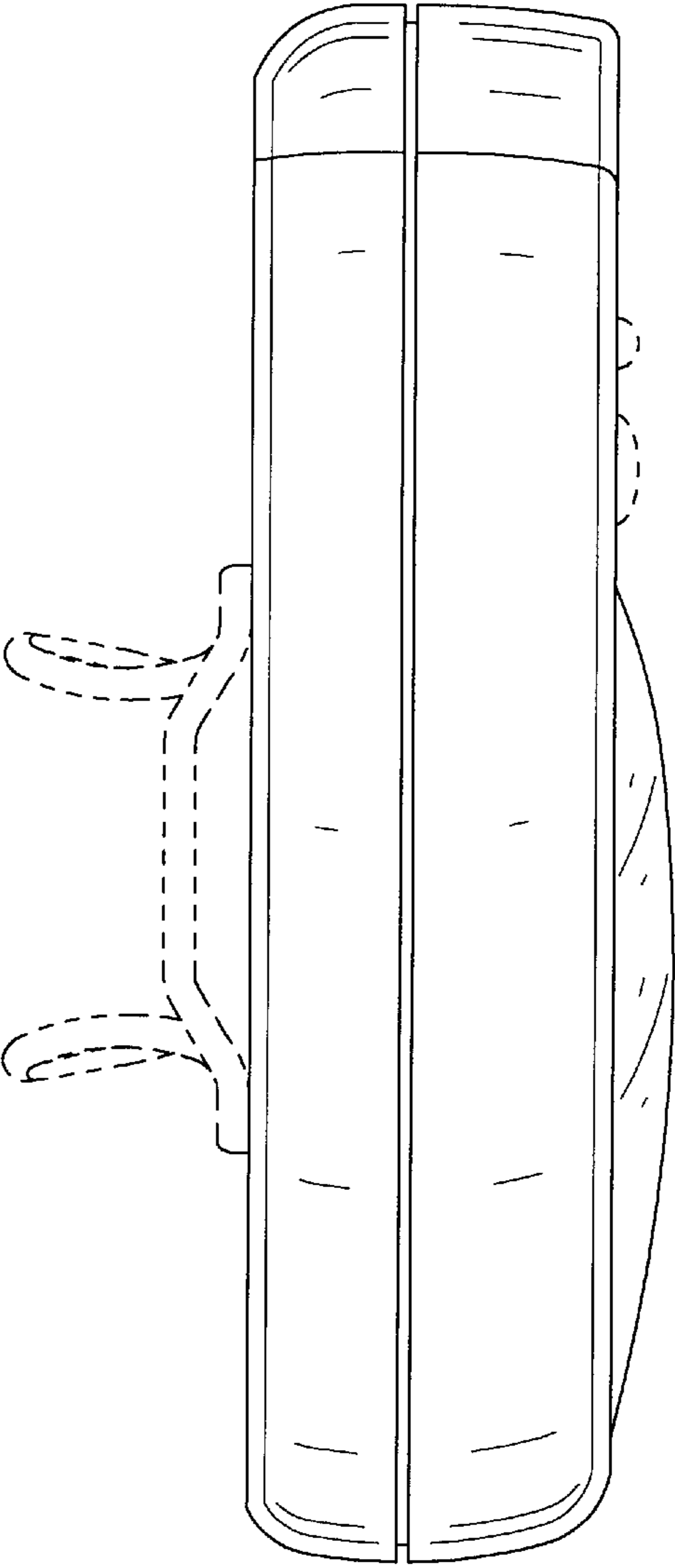

FIG. 4

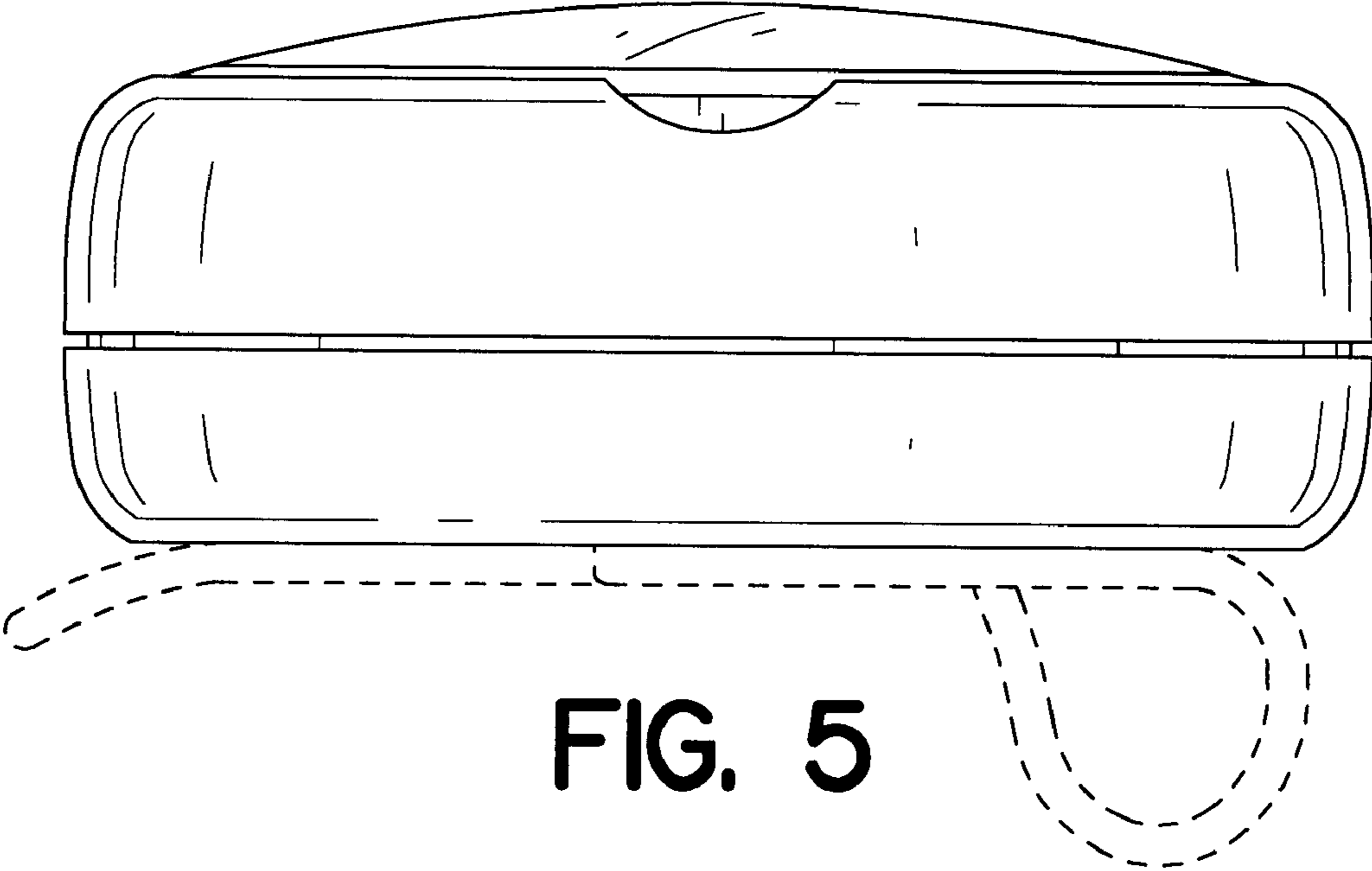

FIG. 5

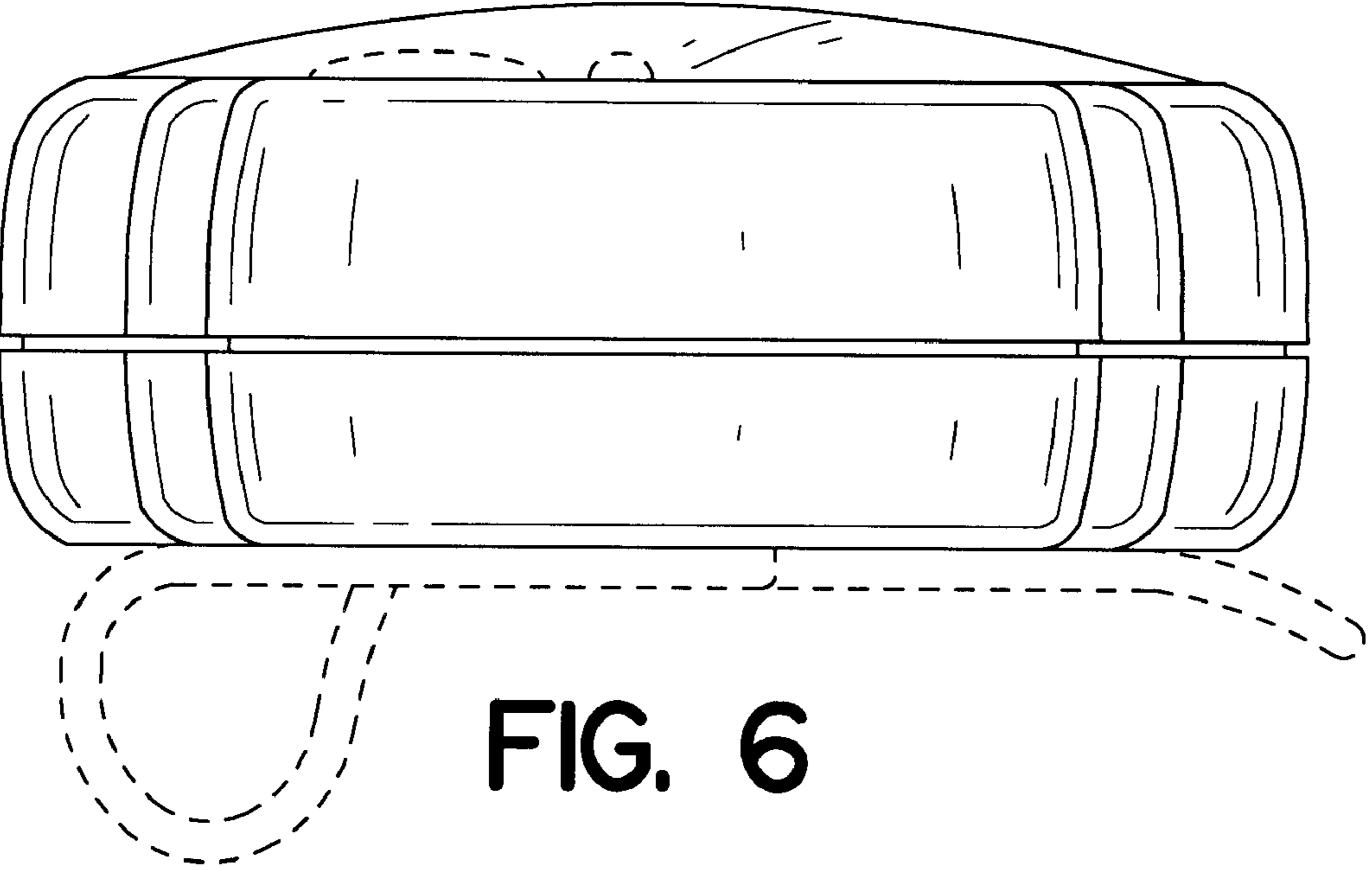

FIG. 6

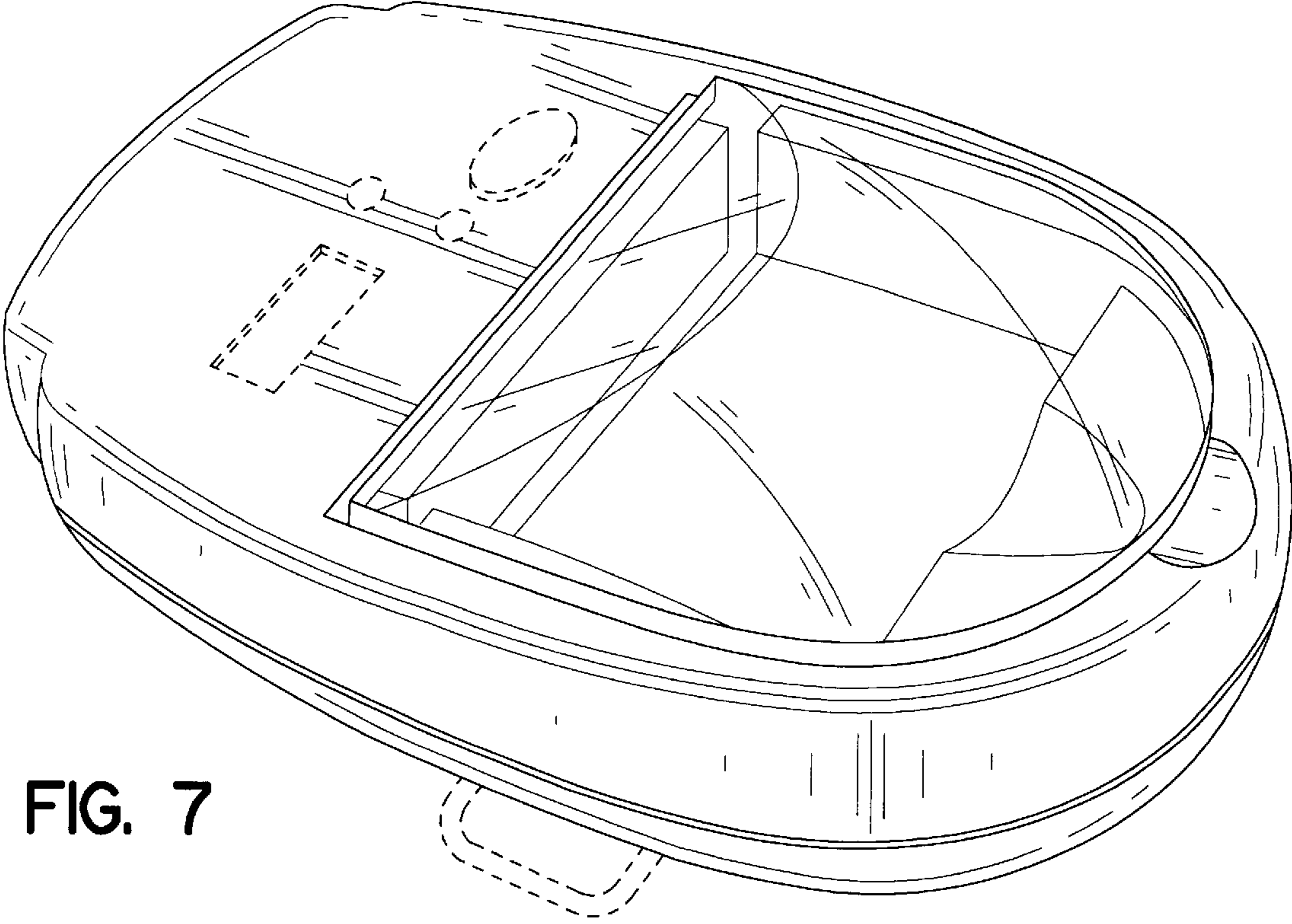

FIG. 7