

US00D493750S1

(12) **United States Design Patent** (10) **Patent No.:** **US D493,750 S**
Crépeau et al. (45) **Date of Patent:** **** Aug. 3, 2004**

(54) **ALL TERRAIN VEHICLE**

(75) Inventors: **Jean-Phillipe Crépeau**, Bromont (CA); **Martin Aubé**, St-Bruno-de-Montarville (CA); **Pierre Rondeau**, St-Denis-de-Brompton (CA); **Martin Portelance**, Sherbrooke (CA)

(73) Assignee: **Bombardier Recreational Products Inc.**, St-Bruno (CA)

(**) Term: **14 Years**

(21) Appl. No.: **29/174,544**

(22) Filed: **Jan. 22, 2003**

(51) **LOC (7) Cl.** **12-11**

(52) **U.S. Cl.** **D12/107**

(58) **Field of Search** D12/87-107; 180/311, 180/312, 315, 225, 229, 233

(56) **References Cited**

U.S. PATENT DOCUMENTS

D289,986 S	*	5/1987	Ooba et al.	D12/107
D293,900 S	*	1/1988	Murakami	D12/107
D298,744 S		11/1988	Saito et al.		
D327,457 S		6/1992	Saito		
D330,694 S		11/1992	Kimura et al.		
D405,029 S		2/1999	Deutschman		
D412,464 S		8/1999	Ichihara et al.		
D415,448 S		10/1999	Deutschman		
D424,982 S		5/2000	Deutschman		
D427,942 S		7/2000	Cho et al.		
D436,559 S	*	1/2001	Fujieda	D12/107
D438,823 S		3/2001	Luh		

OTHER PUBLICATIONS

Honda Motorcycles, 1986 FourTrax 250R, www.hondamotorcycle.com/classics/1986fourtrax250r/index.html, 3 pages.

Yamaha Motorcycles, www.yamaha-motor.com/01motor-sports/01atv/gallerybody.html, 3 pages.

Bombardier Parts Catalog 2000, DS 650, Nov. 1999, 704 300 001.

Sea-Doo Parts Catalog, 1998, XP Limited 5665/5667 (5 pages).

Sea-Doo Parts Catalog, 1998, GTX RFT 5666-5843, (4 pages).

Sea-Doo Parts Catalog. 1998, GTS 5819 (5 pages).

* cited by examiner

Primary Examiner—Alan P. Douglas

Assistant Examiner—Linda Brooks

(74) *Attorney, Agent, or Firm*—Jonathan D. Cutler; BRP -Legal Services

(57) **CLAIM**

The ornamental design for an all terrain vehicle, as shown and described.

DESCRIPTION

FIG. 1 is a front perspective view showing an all terrain vehicle according to our design;

FIG. 2 is a rear perspective view thereof;

FIG. 3 is a top view thereof;

FIG. 4 is a left side view thereof;

FIG. 5 is a right side view thereof;

FIG. 6 is a front view thereof; and,

FIG. 7 is a left rear view thereof.

Where included, the broken lines showing environment or structure are for illustrative purposes only and form no part of claimed design.

1 Claim, 6 Drawing Sheets

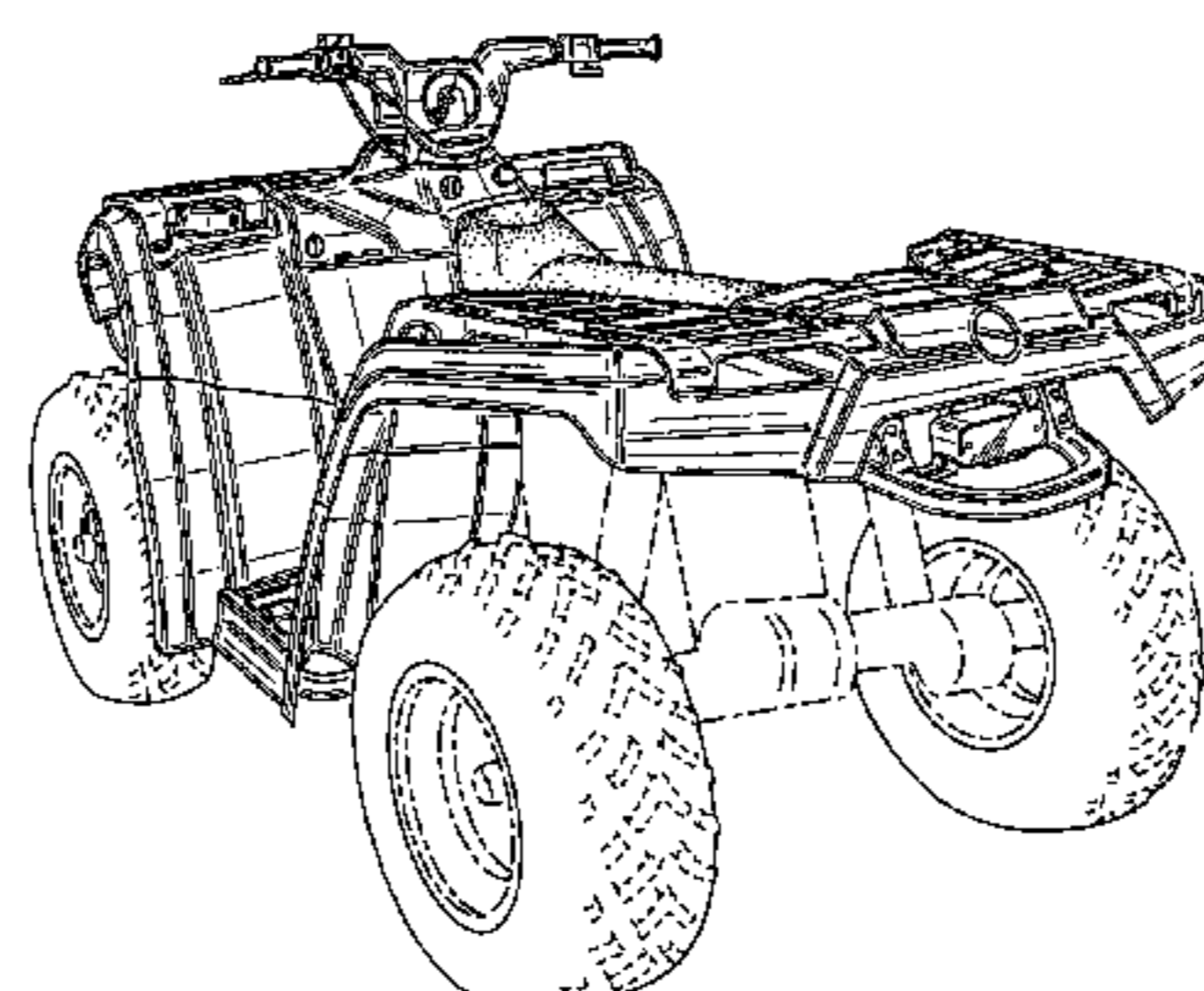
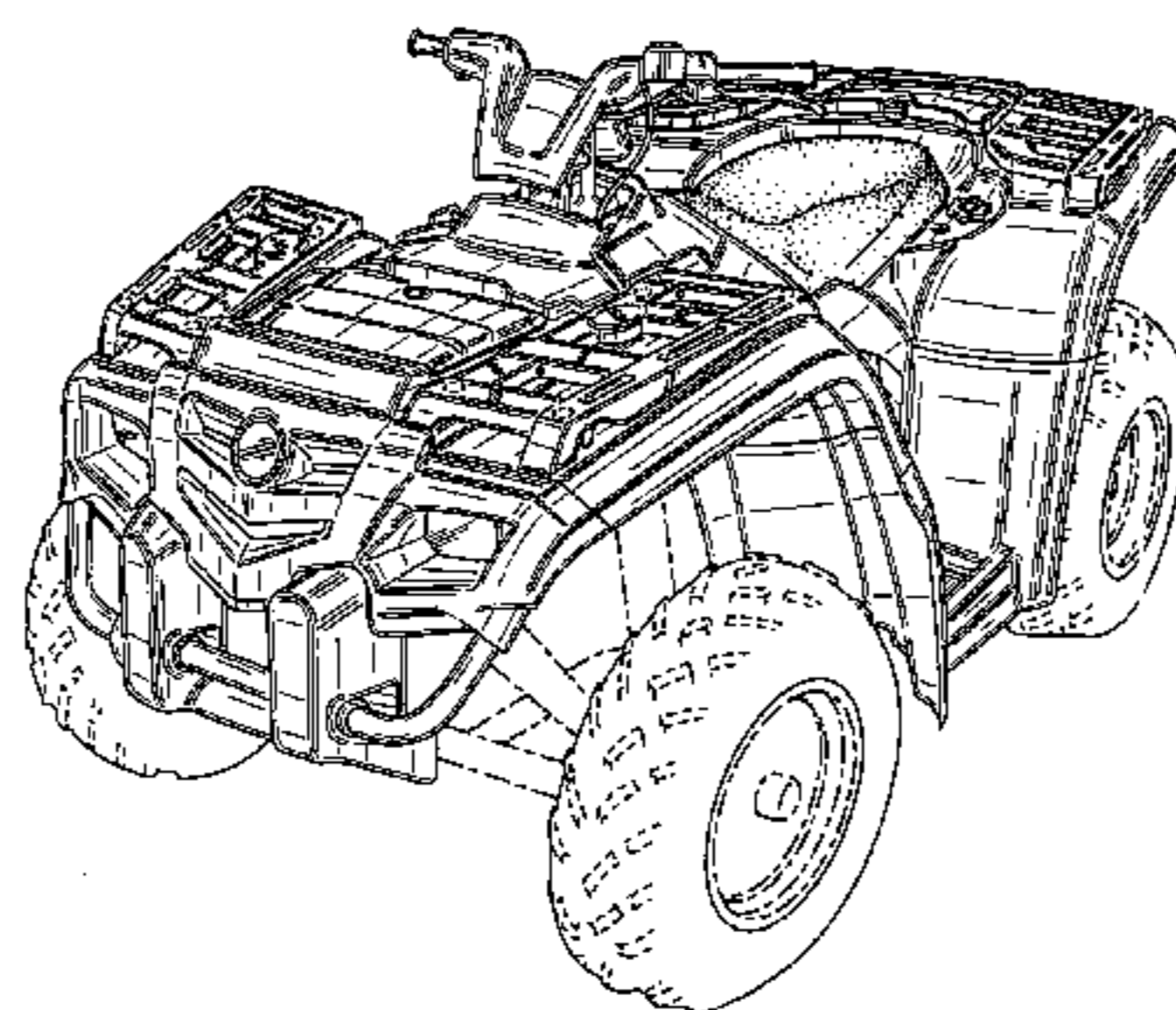

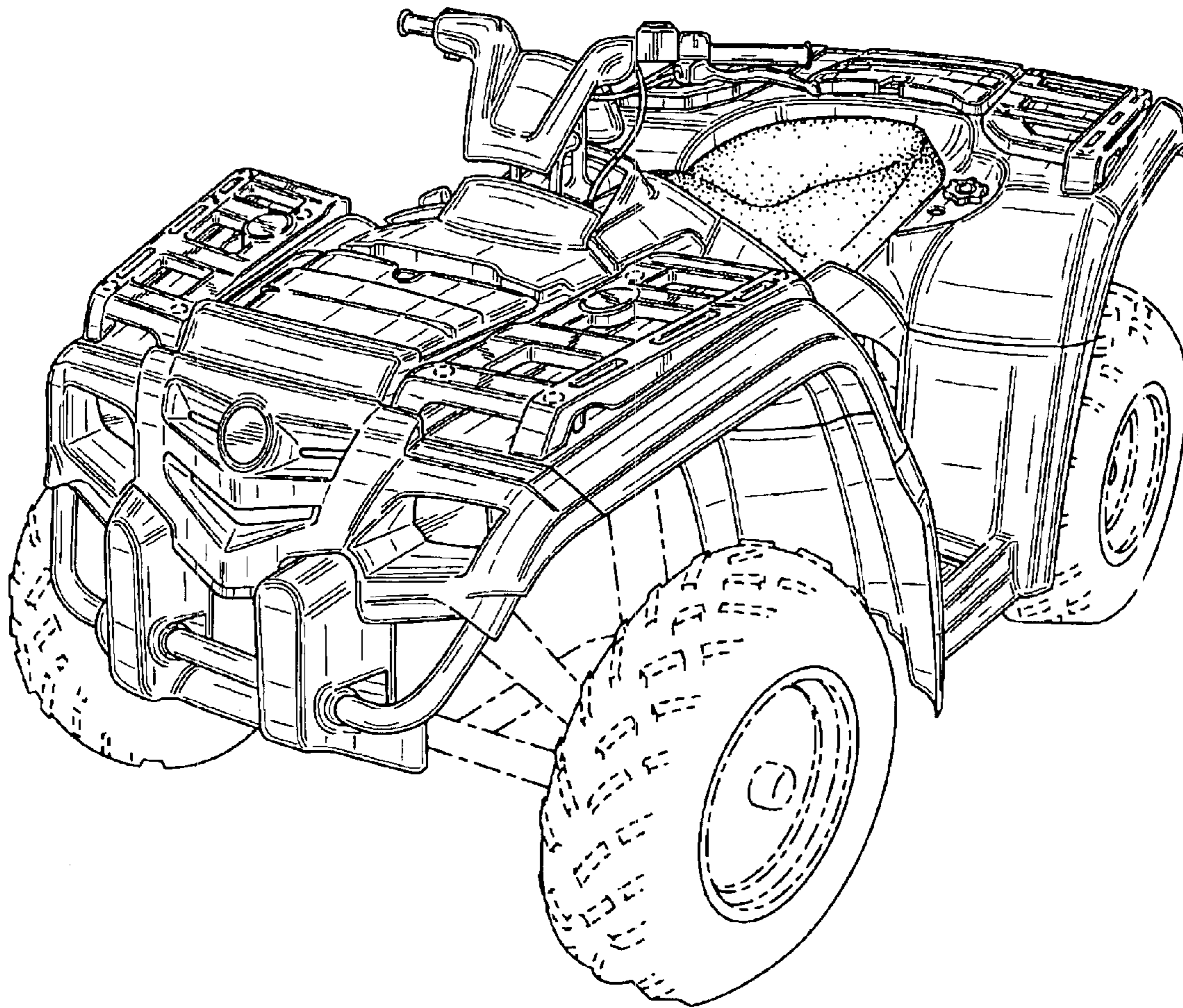

FIG. 1

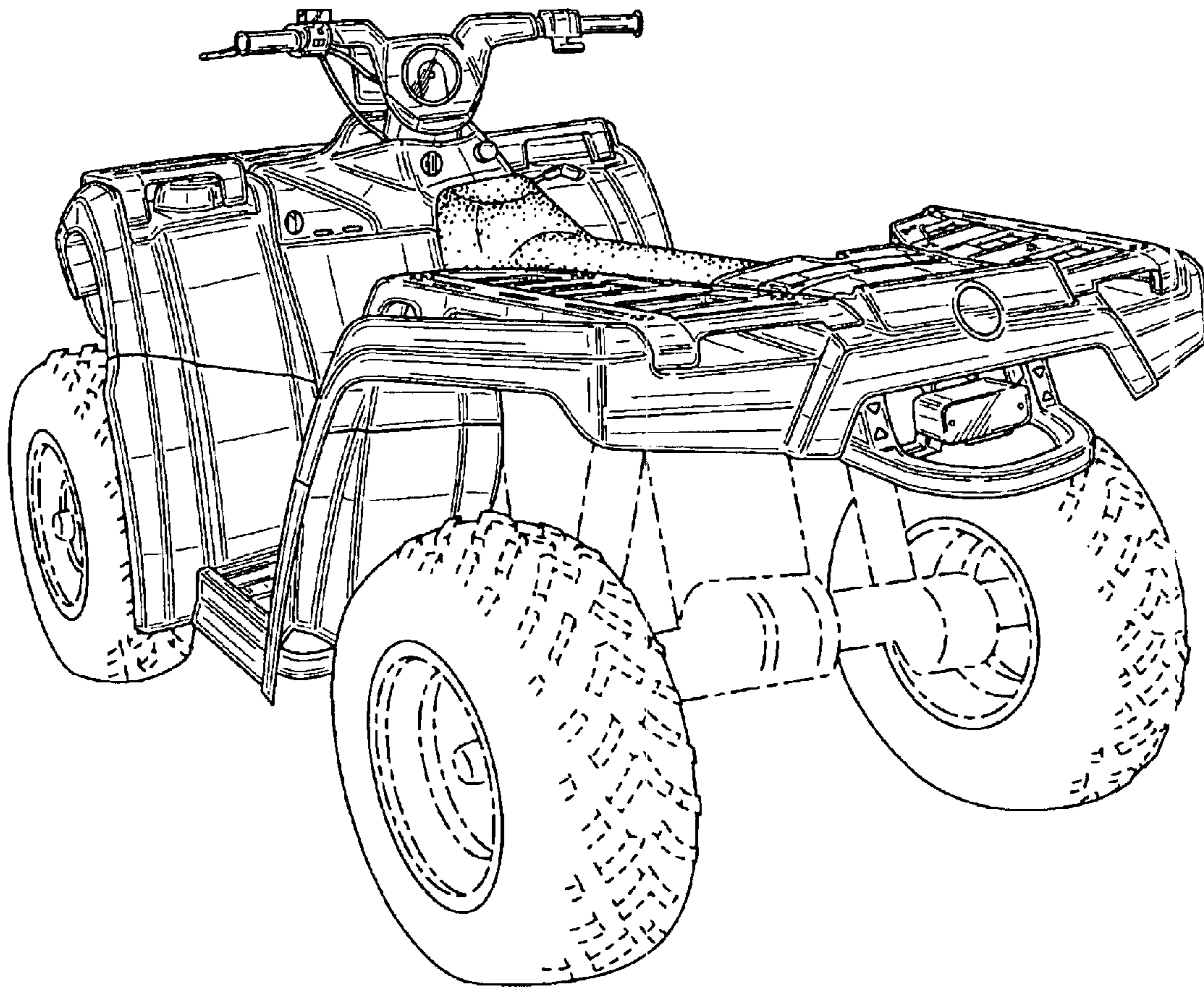

FIG. 2

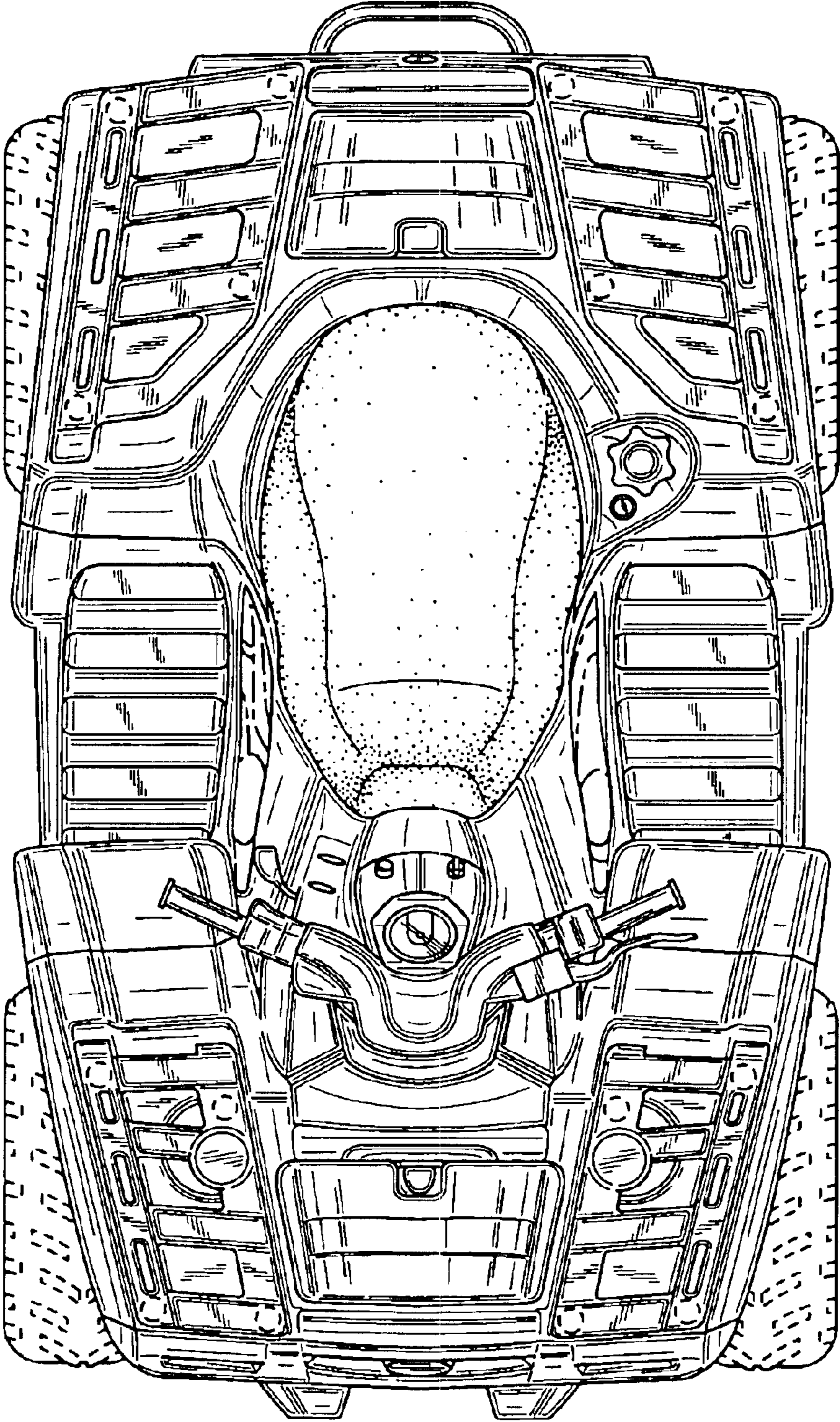

FIG. 3

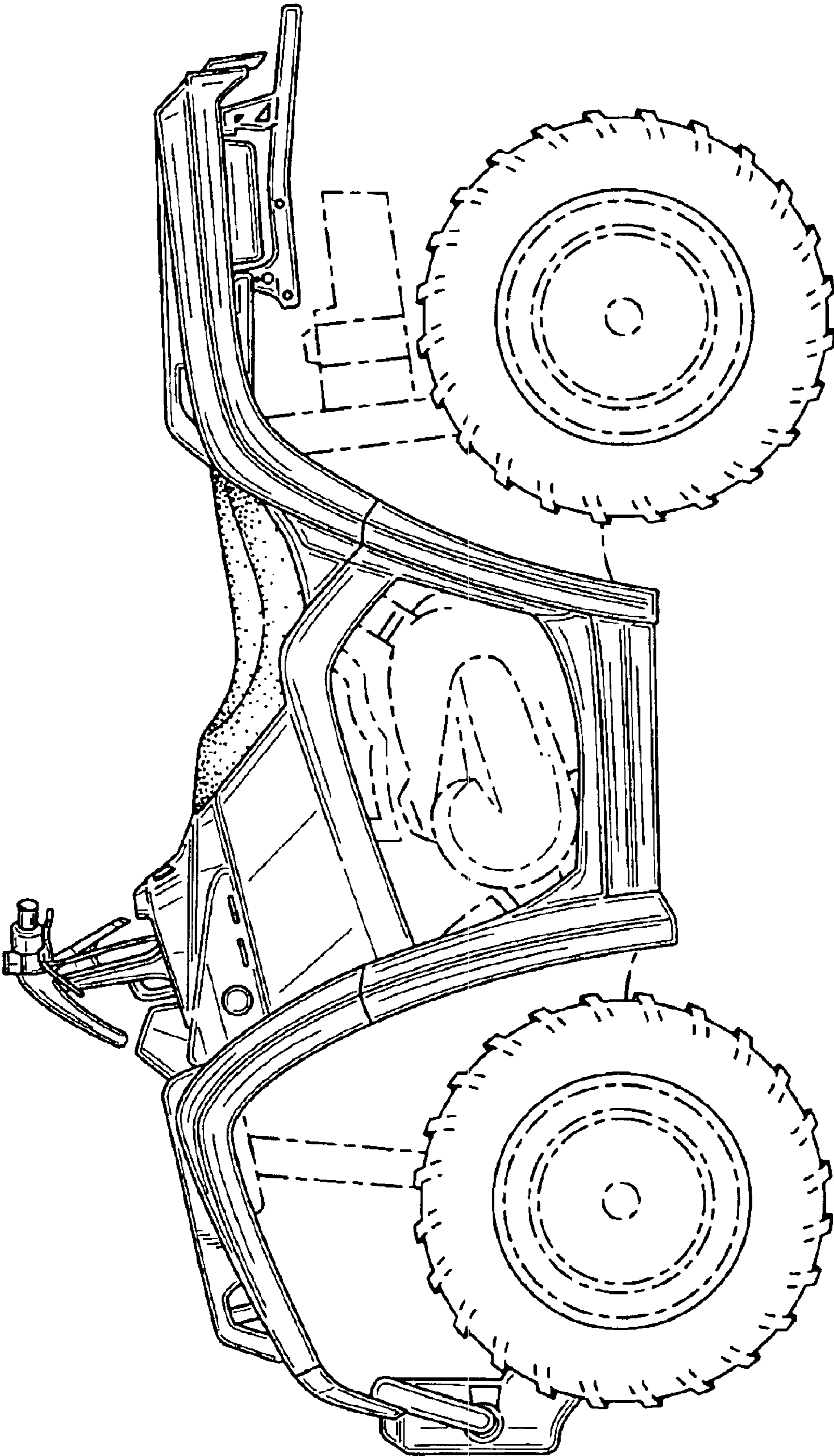

FIG. 4

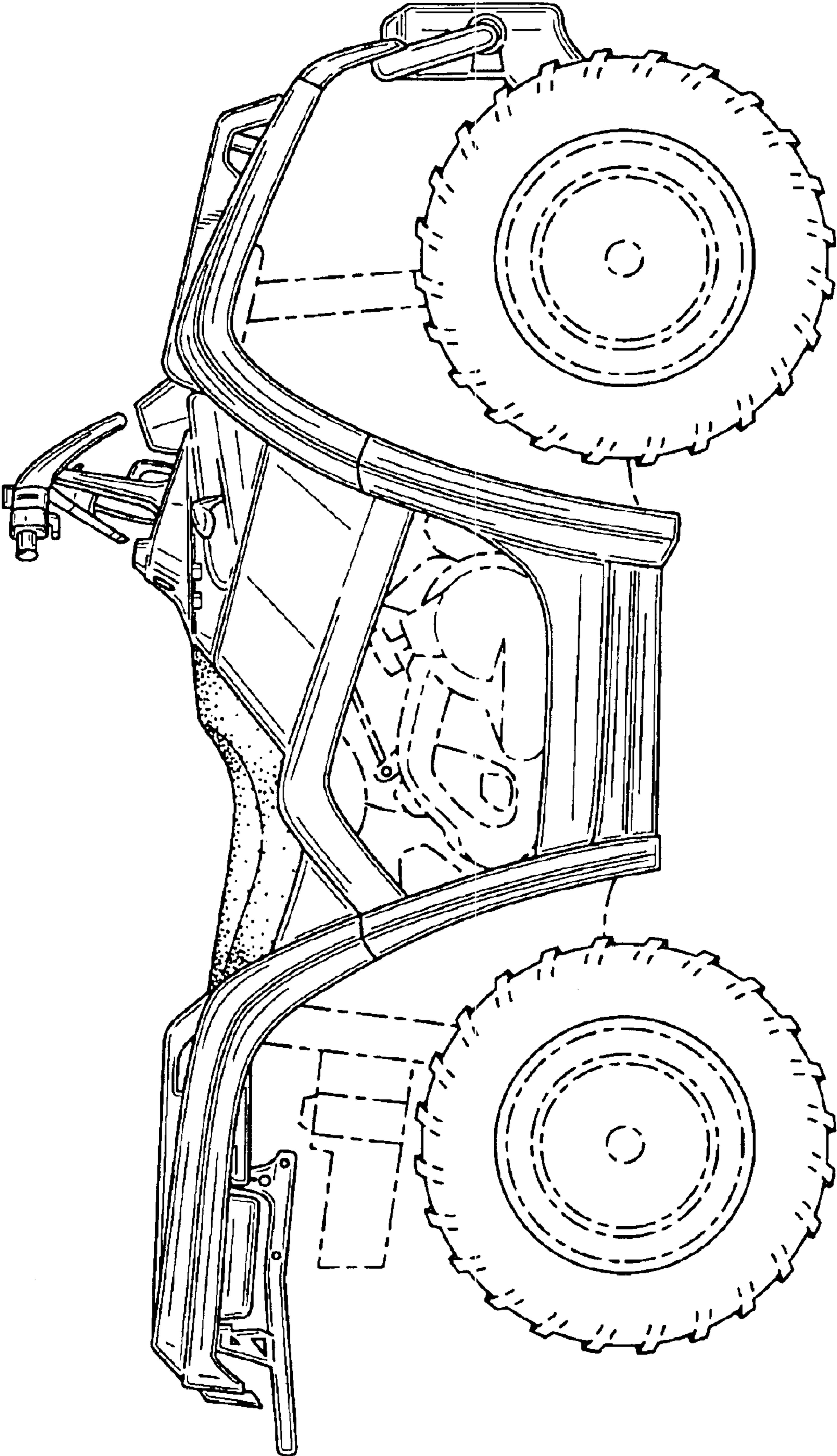

FIG. 5

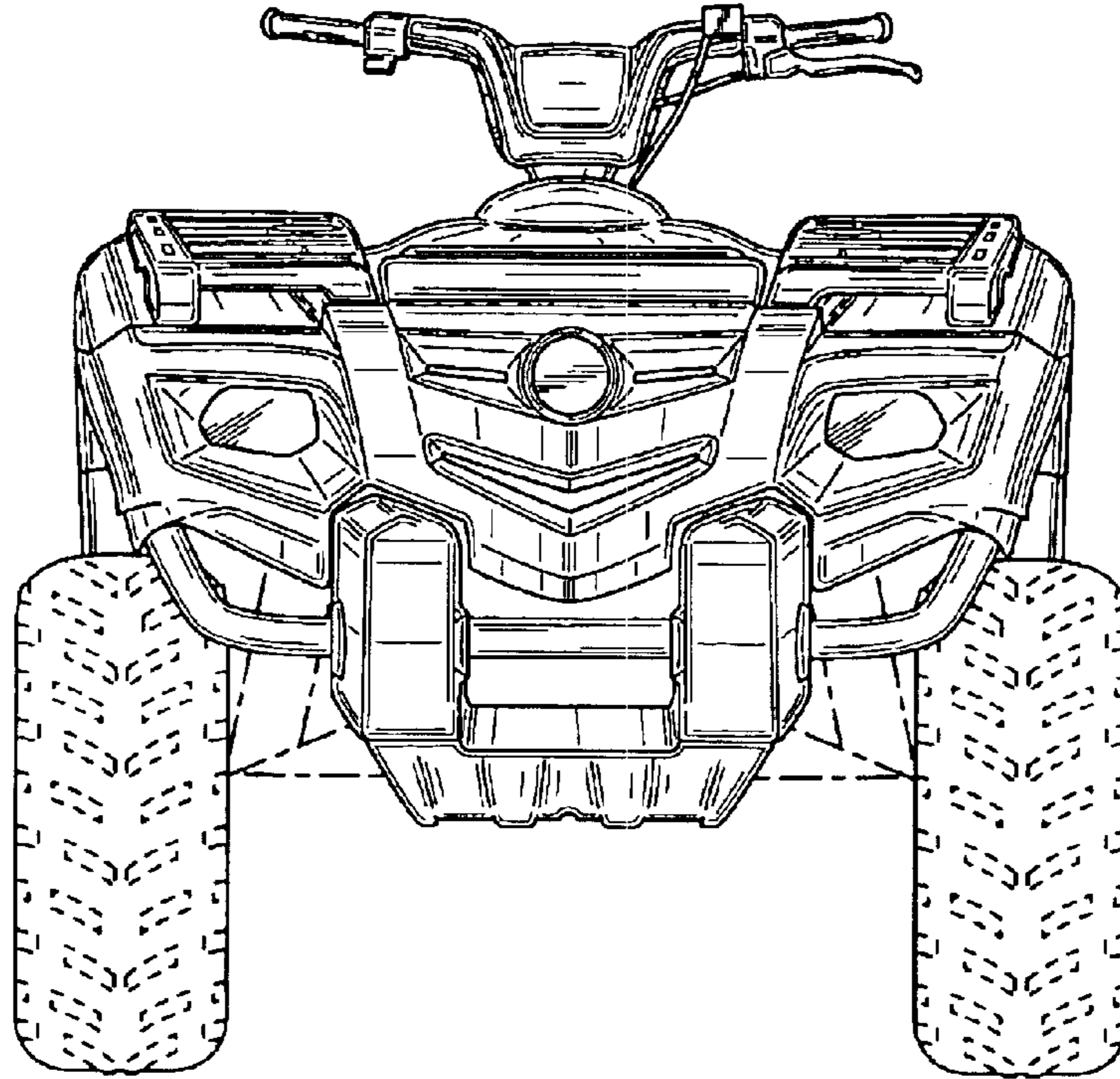

FIG. 6

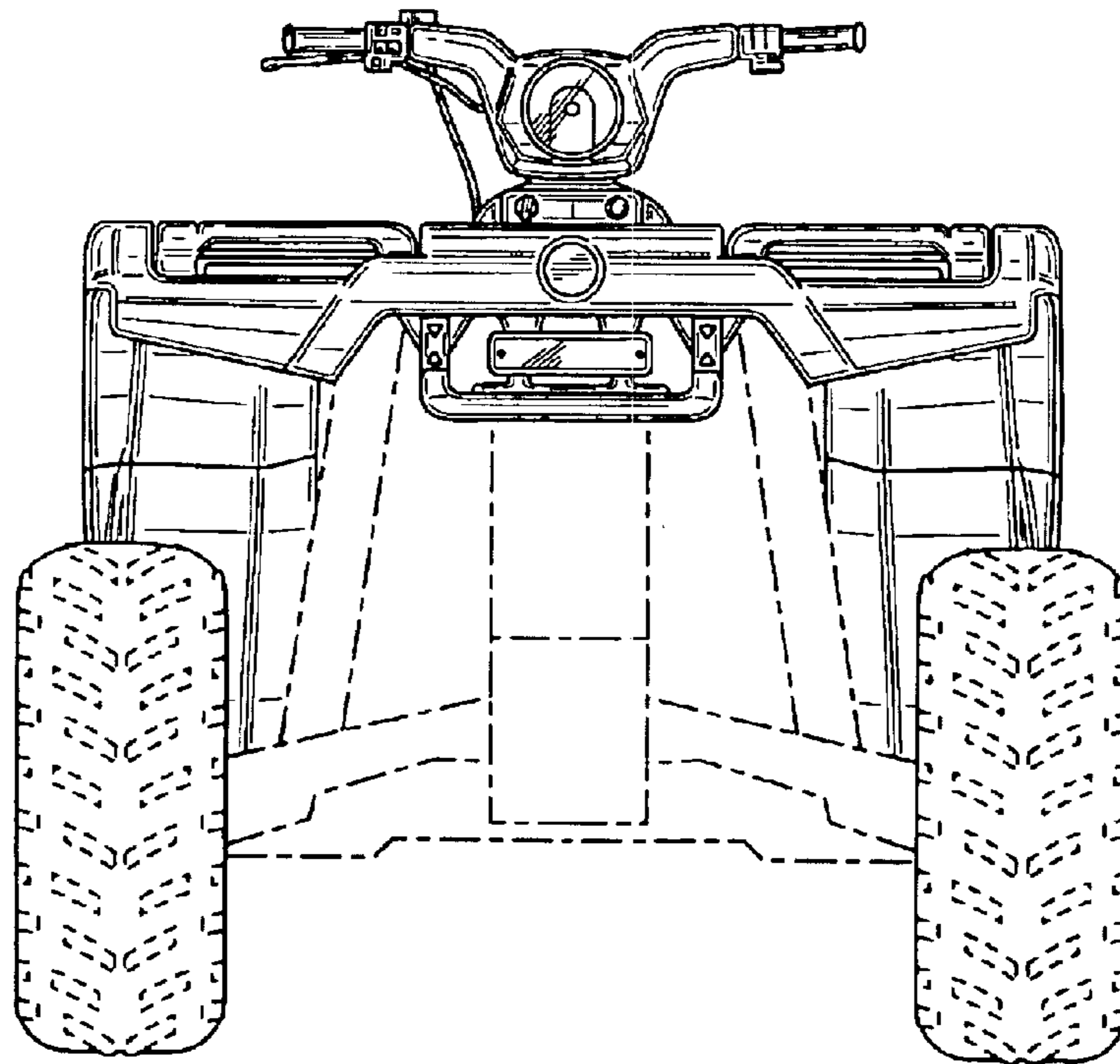

FIG. 7