

US00D493393S1

(12) **United States Design Patent** (10) **Patent No.:** **US D493,393 S**  
**Kneefel et al.** (45) **Date of Patent:** **\*\* Jul. 27, 2004**

(54) **VEHICLE LEFT FRONT FENDER**  
(75) Inventors: **Rolph Kneefel**, Livonia, MI (US);  
**Steve Park**, Victoria (AU)  
(73) Assignee: **Ford Global Technologies, LLC**,  
Dearborn, MI (US)  
(\*\*) Term: **14 Years**  
(21) Appl. No.: **29/173,304**  
(22) Filed: **Dec. 26, 2002**  
(51) **LOC (7) Cl.** ..... **12-16**  
(52) **U.S. Cl.** ..... **D12/184; D12/196**  
(58) **Field of Search** ..... D12/184, 196,  
D12/90-92; 280/152.1, 847-849, 851; 296/185

(56) **References Cited**

**U.S. PATENT DOCUMENTS**

D317,586 S	*	6/1991	Yoshinao et al.	.....	D12/184
D447,458 S	*	9/2001	Eum	.....	D12/196
D455,372 S	*	4/2002	Myles et al.	.....	D12/98
D459,686 S	*	7/2002	Sinkwitz	.....	D12/196
D472,194 S	*	3/2003	Tanabe et al.	.....	D12/196

**OTHER PUBLICATIONS**

Photographs of commercial parts—2 pages.  
LINCOLN-MERCURY; excerpts from product brochure entitled “2002 Mercury”.  
LINCOLN-MERCURY; excerpts from product brochure entitled “2002 Mercury Grand Marquis”.  
LINCOLN-MERCURY; excerpts from product brochure; published circa 2001.  
LINCOLN-MERCURY; excerpts from product specification entitled “2001 Mercury Grand Marquis”.  
LINCOLN-MERCURY; excerpts from product brochure entitled “Mercury 2000”.  
LINCOLN-MERCURY; excerpts from product brochure entitled “Mercury Grand Marquis 1999”.  
LINCOLN-MERCURY; excerpts from product brochure entitled “1998 Mercury Grand Marquis”.

LINCOLN-MERCURY; excerpts from product brochure entitled “Presenting the new Mercury Grand Marquis”.  
LINCOLN-MERCURY; excerpts from product brochure entitled “1997 Grand Marquis”.  
LINCOLN-MERCURY; excerpts from product brochure entitled “Imagine Yourself In A Mercury; 1996-Sable-Mystique-Villager-Grand Marquis-Cougar XR7-Tracer”.  
LINCOLN-MERCURY; excerpts from product brochure entitled “Imagine Yourself In A Mercury Grand Marquis; ’96 Mercury”.  
LINCOLN-MERCURY; excerpts from product brochure entitled “Imagine Yourself In A Mercury Grand Marquis”. Excerpts from article entitled “Mercury’s Hugh Grand Marquis Is An Agile, Friendly, Economical Dinosaur”; published circa 1994.  
LINCOLN-MERCURY; excerpts from product brochure entitled “1995 Mercury”.

(List continued on next page.)

*Primary Examiner*—Melody N. Brown  
(74) *Attorney, Agent, or Firm*—David B. Kelley

(57) **CLAIM**

The ornamental design for a vehicle left front fender, as shown and described.

**DESCRIPTION**

FIG. 1 is a perspective view of a left front fender in accordance with an embodiment of the present invention; FIG. 2 is a side view of the left front fender shown in FIG. 1;  
FIG. 3 is the other side view of the left front fender shown in FIG. 1;  
FIG. 4 is a front view of the left front fender shown in FIG. 1; and,  
FIG. 5 is a top view of the left front fender shown in FIG. 1.  
The bottom and rear views of the left front fender are not part of the claimed design. The broken lines illustrate the environment of the design and are not part of the claimed design.

**1 Claim, 2 Drawing Sheets**

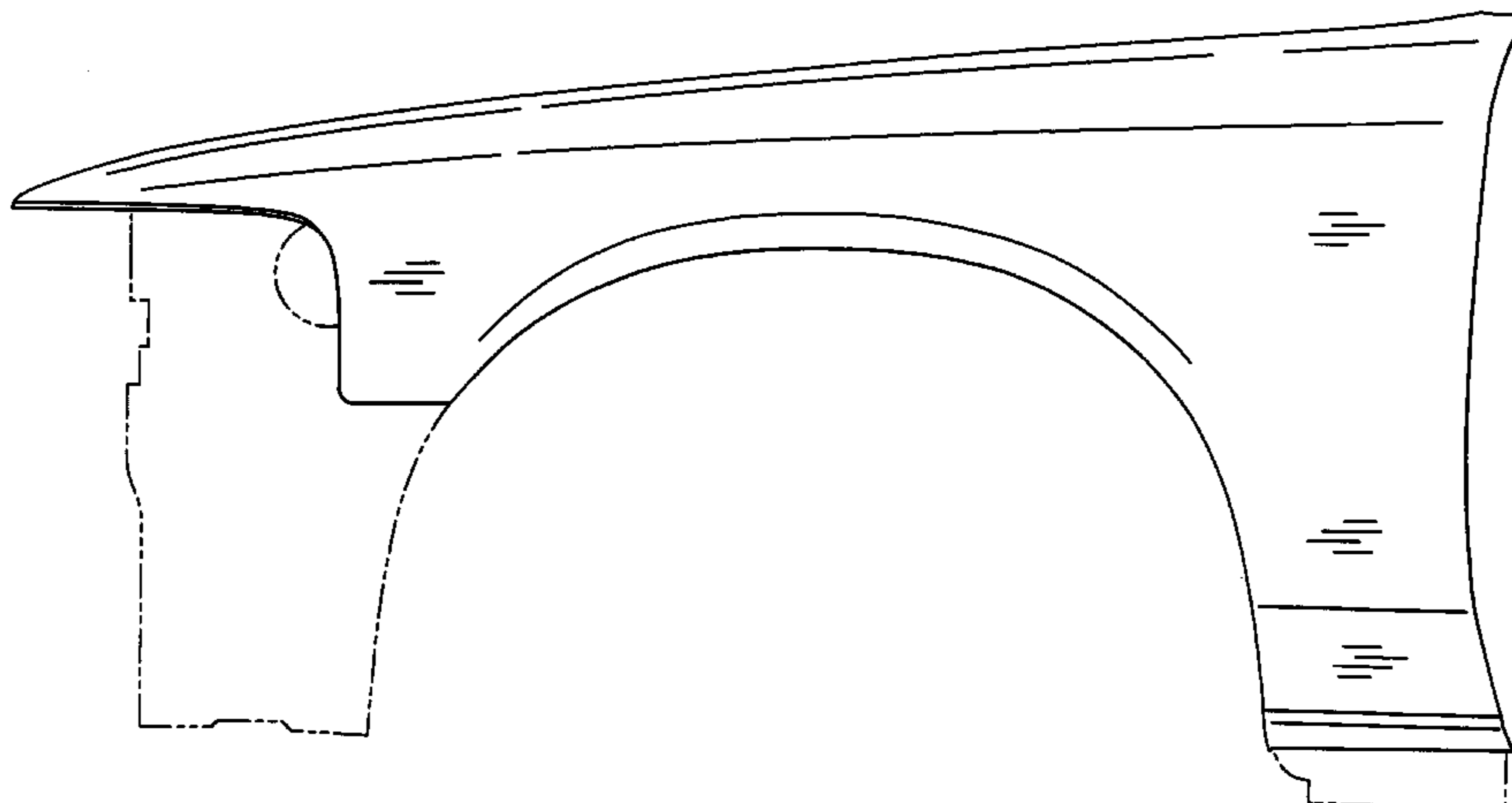

## OTHER PUBLICATIONS

LINCOLN-MERCURY; excerpts from product brochure entitled "1994 Product Information; Grand Marquis".

LINCOLN-MERCURY; excerpts from product brochure entitled "1994 Mercurys. All this and the quality of a Mercury".

LINCOLN-MERCURY; excerpts from product brochure entitled "1993 Mercury Grand Marquis".

LINCOLN-MERCURY; excerpts from product brochure entitled "Mercury Grand Marquis"; published circa 1993.

LINCOLN-MERCURY; excerpts from product brochure entitled "1992 Mercury, Sable, Grand Marquis, Cougar, Tracer, Topaz, Capri".

LINCOLN-MERCURY; excerpts from product brochure entitled "When You Think About Your Next Car Think On A Grand Scale"; published circa 1992.

LINCOLN-MERCURY; excerpts from product brochure entitled "1992 Mercury Grand Marquis".

LINCOLN-MERCURY; excerpts from product brochure entitled "Mercury Grand Marquis; Grand Marquis 1992".

Excerpts from article entitled "92 Grand Marquis unveiled"; published circa Dec. 1990.

Excerpts from article entitled "Big Changes In Store For '92 Marquis"; published circa Nov. 1990.

Photograph of Mercury Grand Marquis from article; published circa 1992.

LINCOLN-MERCURY; excerpts from product brochure entitled "1992 Mercury Grand Marquis Major Product Changes".

LINCOLN-MERCURY; excerpts from product brochure entitled "Grand Marquis"; published circa 1991.

Excerpts from article entitled "Grand Marquis Has The Juice" published circa 1991.

LINCOLN-MERCURY; excerpts from product brochure entitled "Mercury-Cougar, Sable, Topaz, Tracer, Grand Marquis"; published circa 1990.

LINCOLN-MERCURY; excerpts from product brochure entitled "Mercury '90 Grand Marquis".

LINCOLN-MERCURY; excerpts from product brochure entitled "1990 Mercury Grand Marquis/Colony Park—major product changes".

LINCOLN-MERCURY; excerpts from product brochure entitled "1989 Mercury Grand Marquis".

LINCOLN-MERCURY; excerpts from product brochure entitled "Good Things Come In Preferred Equipment Packages"; published circa 1989.

LINCOLN-MERCURY; excerpts from product brochure entitled "Mercury-Cougar, Sable, Topaz, Tracer, Grand Marquis"; published circa 1989.

LINCOLN-MERCURY; excerpts from product brochure entitled "Mercury '89, Cougar, Sable, Topaz, Tracer, Grand Marquis".

LINCOLN-MERCURY; excerpts from product brochure entitled "Mercury '89 Grand Marquis Brochure".

LINCOLN-MERCURY; excerpts from product brochure entitled "Tracer, Topaz-Grand Marquis"; published circa 1988".

LINCOLN-MERCURY; excerpts from product brochure entitled "1988 Grand Marquis".

LINCOLN-MERCURY; excerpts from product brochure entitled "1987 Mercury".

LINCOLN-MERCURY; excerpts from product brochure entitled "Tracer-Topaz-Grand Marquis-Sable-Cougar".

LINCOLN-MERCURY; excerpts from product brochure entitled "Mercury '87, Sable/Cougar/Topaz/Lynx/Grand Marquis".

LINCOLN-MERCURY; excerpts from product brochure entitled "Mercury Grand Marquis '86".

LINCOLN-MERCURY; excerpts from product brochure entitled "Mercury '86, Sable/Cougar/Topaz/Lyx/Capri/Grand Marquis".

LINCOLN-MERCURY; excerpts from product brochure entitled "Mercury '85".

LINCOLN-MERCURY; excerpts from product brochure entitled "Mercury Marquis '85".

LINCOLN-MERCURY; excerpts from product brochure entitled "Mercury Grand Marquis '85".

LINCOLN-MERCURY; excerpts from product brochure entitled "1985 Mercury—Competitive Comparisons".

LINCOLN-MERCURY; excerpts from product brochure entitled "1985 Lincoln-Mercury, Close-up news bulletin No. 3".

LINCOLN-MERCURY; excerpts from product brochure entitled "1984 Mercury Grand Marquis".

LINCOLN-MERCURY; excerpts from product brochure entitled "1984 Lincoln-Mercury Advance Fleet Buyers Guide".

LINCOLN-MERCURY; excerpts from product brochure entitled "1984 Mercury, Topaz, Lynx, Capri, Cougar, Marquis, Grand Marquis".

LINCOLN-MERCURY; excerpts from product brochure entitled "1983 Mercury Grand Marquis".

LINCOLN-MERCURY; excerpts from product brochure entitled "Fleet Facts 1983 Grand Marquis".

LINCOLN-MERCURY; excerpts from product brochure entitled "Lincoln-Mercury for 1983".

LINCOLN-MERCURY; excerpts from product brochure entitled "1983 fleet programs for Lincoln-Mercury Car Lines".

LINCOLN-MERCURY; excerpts from product brochure entitled "Mercury '83".

LINCOLN-MERCURY; excerpts from product brochure entitled "Mercury Grand Marquis '83".

LINCOLN-MERCURY; excerpts from product brochure entitled "Mercury Marquis"; published circa 1983.

\* cited by examiner

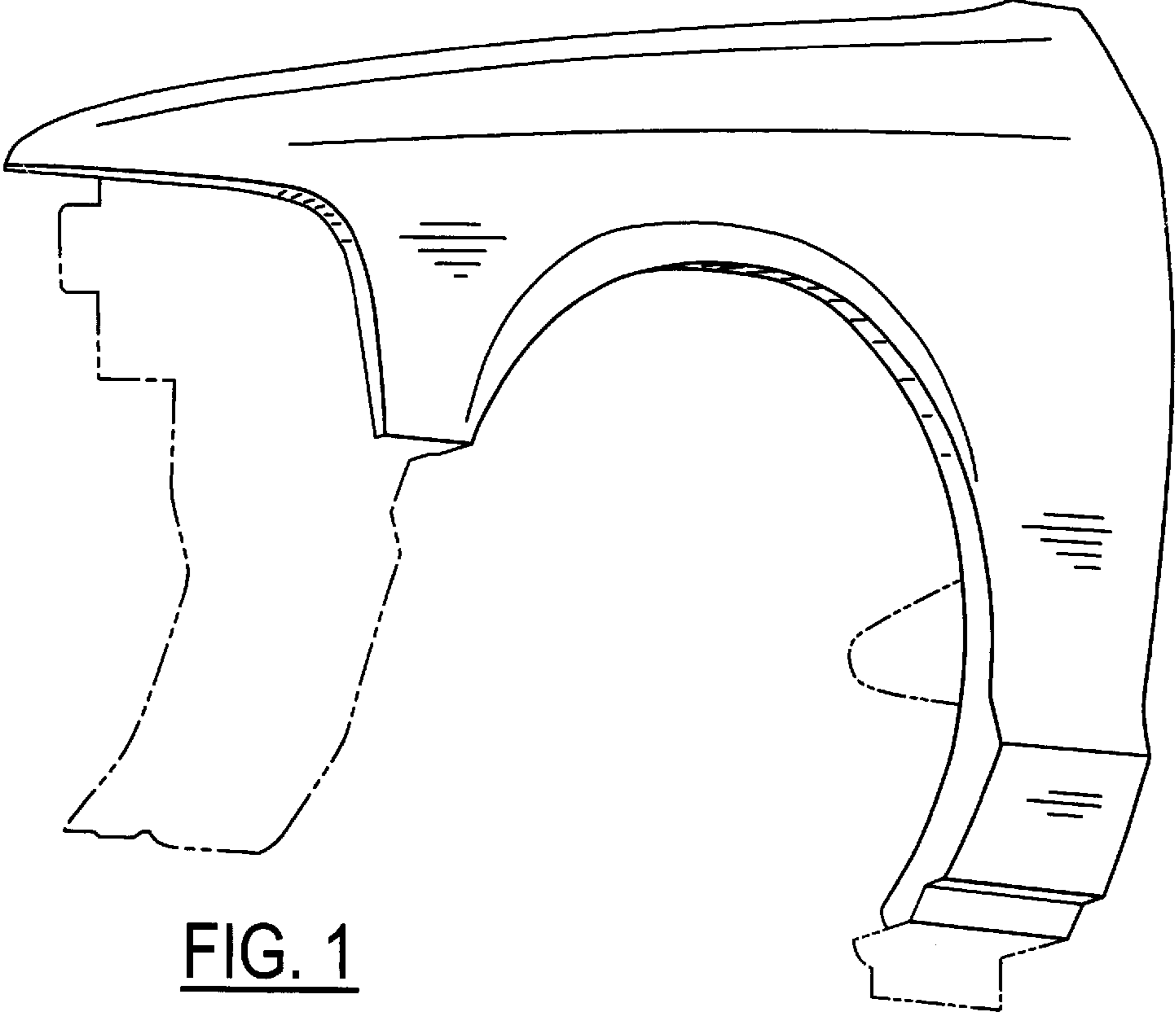

FIG. 1

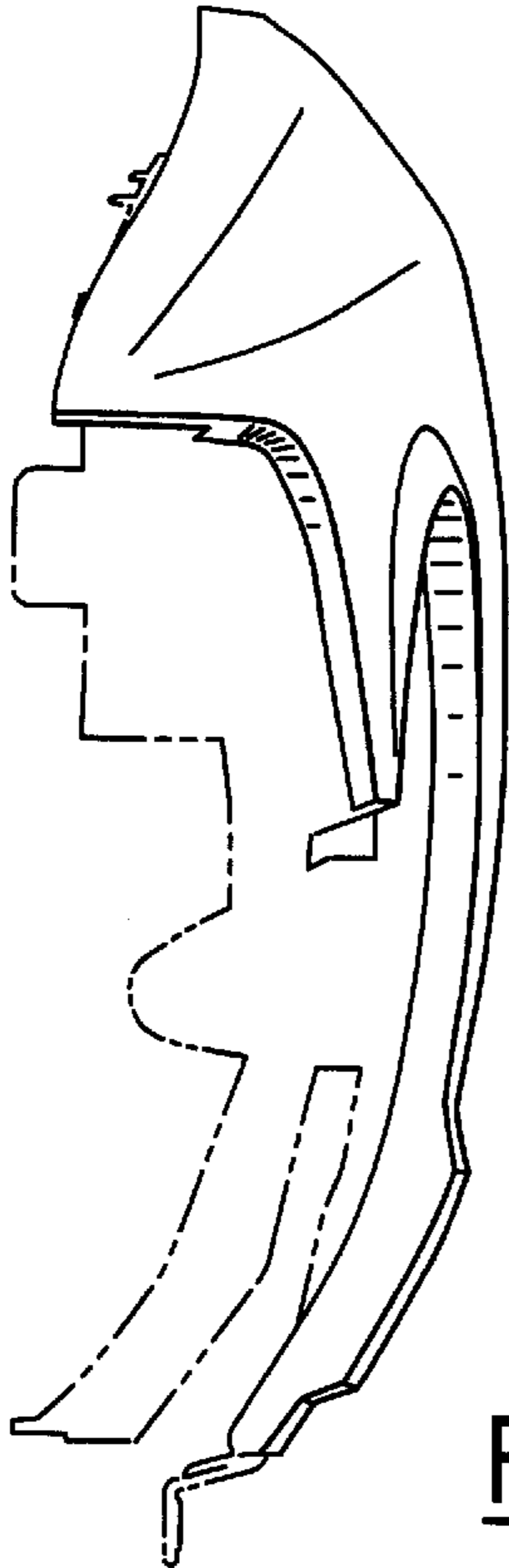
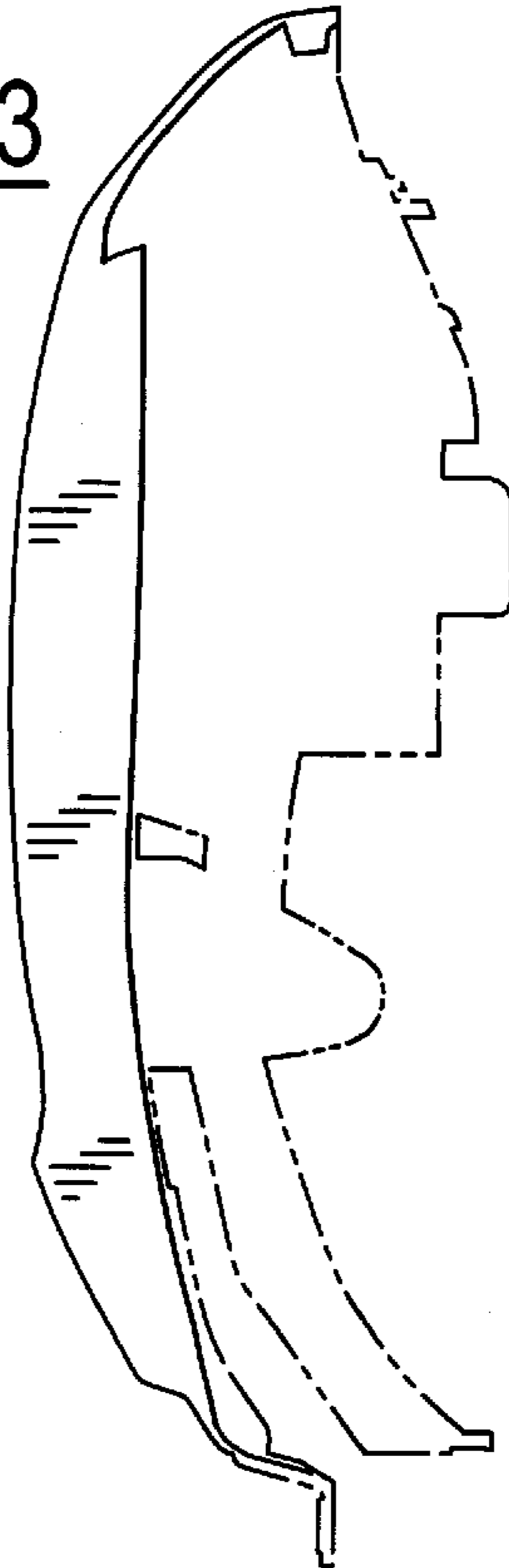

FIG. 2

FIG. 3



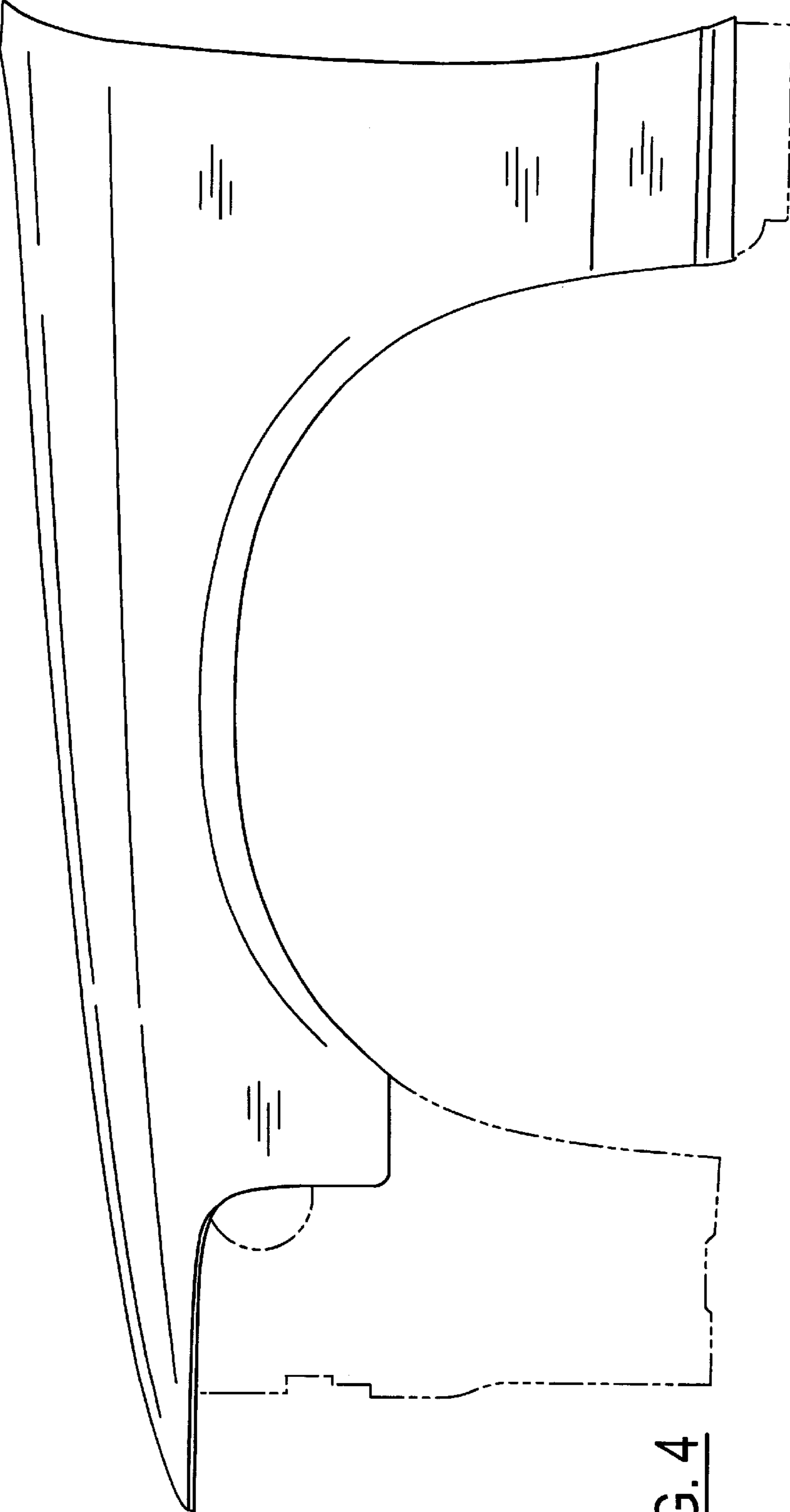

FIG. 4

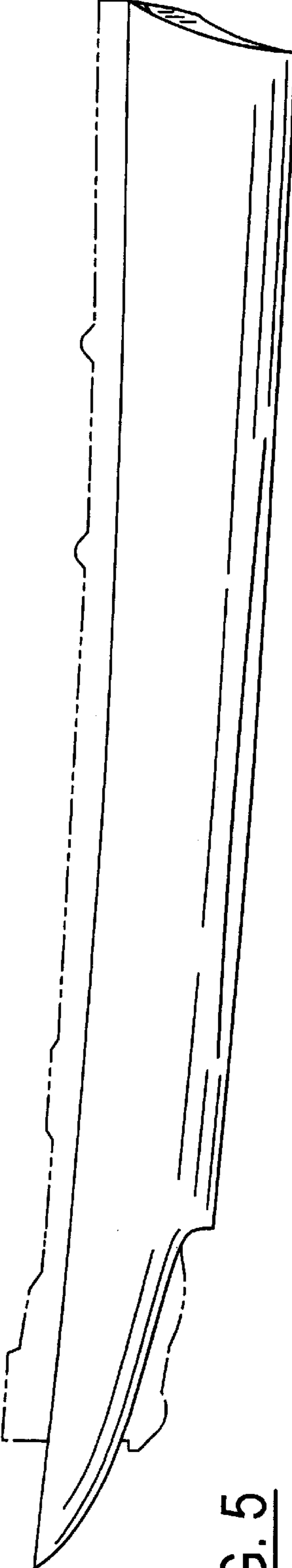

FIG. 5