

US00D493391S1

(12) **United States Design Patent**
Gunter

(10) **Patent No.:** **US D493,391 S**

(45) **Date of Patent:** **** Jul. 27, 2004**

- (54) **THREE WHEELED VEHICLE**
- (75) Inventor: **David M. Gunter**, Centerville, OH (US)
- (73) Assignee: **Huffy Corporation**, Miamisburg, OH (US)
- (**) Term: **14 Years**
- (21) Appl. No.: **29/175,509**
- (22) Filed: **Feb. 6, 2003**
- (51) **LOC (7) Cl.** **12-11**
- (52) **U.S. Cl.** **D12/112**
- (58) **Field of Search** D12/112; 280/242.1, 280/263, 224, 225, 232-236, 249, 250, 282, 288.1; D21/435

- 4,572,535 A 2/1986 Stewart et al.
- 4,580,802 A 4/1986 Herman et al.
- 4,618,160 A 10/1986 McElfresh
- 4,705,284 A 11/1987 Stout
- 4,789,173 A 12/1988 Lofgren et al.
- 4,799,704 A 1/1989 Colarusso
- 4,826,190 A 5/1989 Hartmann
- 4,892,323 A 1/1990 Oxford
- 5,145,196 A 9/1992 Langkamp
- 5,383,676 A 1/1995 Valentino
- 5,501,478 A 3/1996 Doan
- 5,568,935 A 10/1996 Mason
- 6,062,581 A 5/2000 Stites
- 6,352,274 B1 3/2002 Redman
- 6,402,174 B1 6/2002 Maurer
- D460,027 S 7/2002 Shafer et al.

Primary Examiner—Alan P. Douglas
Assistant Examiner—Linda Broks
 (74) *Attorney, Agent, or Firm*—Howrey Simon Arnold & White, LLP; Michael J. Bell

(56) **References Cited**
 U.S. PATENT DOCUMENTS

- 1,599,223 A 2/1926 Epps
- 3,311,388 A 3/1967 Ryan et al.
- 3,532,351 A 10/1970 Kaufman
- 3,669,468 A 6/1972 Rich
- 3,753,577 A 8/1973 Robinson
- 3,960,392 A 6/1976 Read
- 3,981,516 A 9/1976 Haggkvist
- 4,072,325 A 2/1978 Bright et al.
- 4,103,921 A 8/1978 Brooks et al.
- D251,264 S 3/1979 Cook et al.
- 4,198,072 A 4/1980 Hopkins
- 4,279,429 A 7/1981 Hopkins
- 4,359,231 A 11/1982 Mulcahy
- 4,431,205 A 2/1984 Speicher et al.
- 4,432,561 A 2/1984 Feikema et al.
- 4,451,064 A 5/1984 Perkins
- 4,456,277 A 6/1984 Carpenter
- 4,497,502 A 2/1985 Forbes et al.
- 4,524,987 A 6/1985 Kim
- 4,526,392 A 7/1985 Berkstresser

(57) **CLAIM**

The ornamental design for a three wheeled vehicle, as shown and described.

DESCRIPTION

FIG. 1 is a perspective view of a three wheeled vehicle embodying my design;
 FIG. 2 is a perspective view thereof with the control levers and rear wheels in an alternate position;
 FIG. 3 is a front elevational view of the view depicted in FIG. 1;
 FIG. 4 is a rear elevational view thereof;
 FIG. 5 is a right side elevational view thereof;
 FIG. 6 is a left side elevational view thereof;
 FIG. 7 is a top plan view thereof; and,
 FIG. 8 is a bottom plan view thereof.
 The pedals are shown in different positions of use in the drawing views.

1 Claim, 8 Drawing Sheets

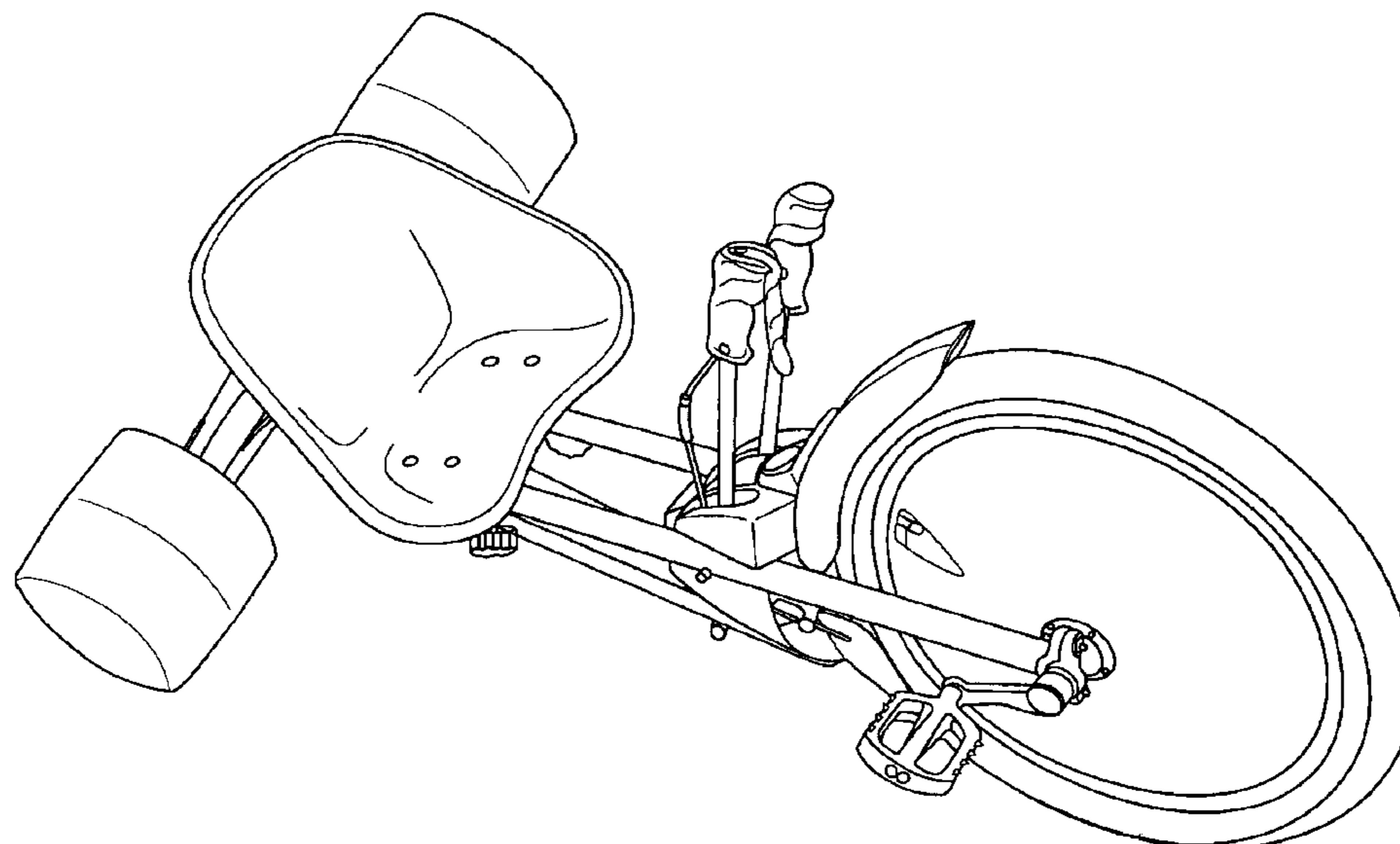

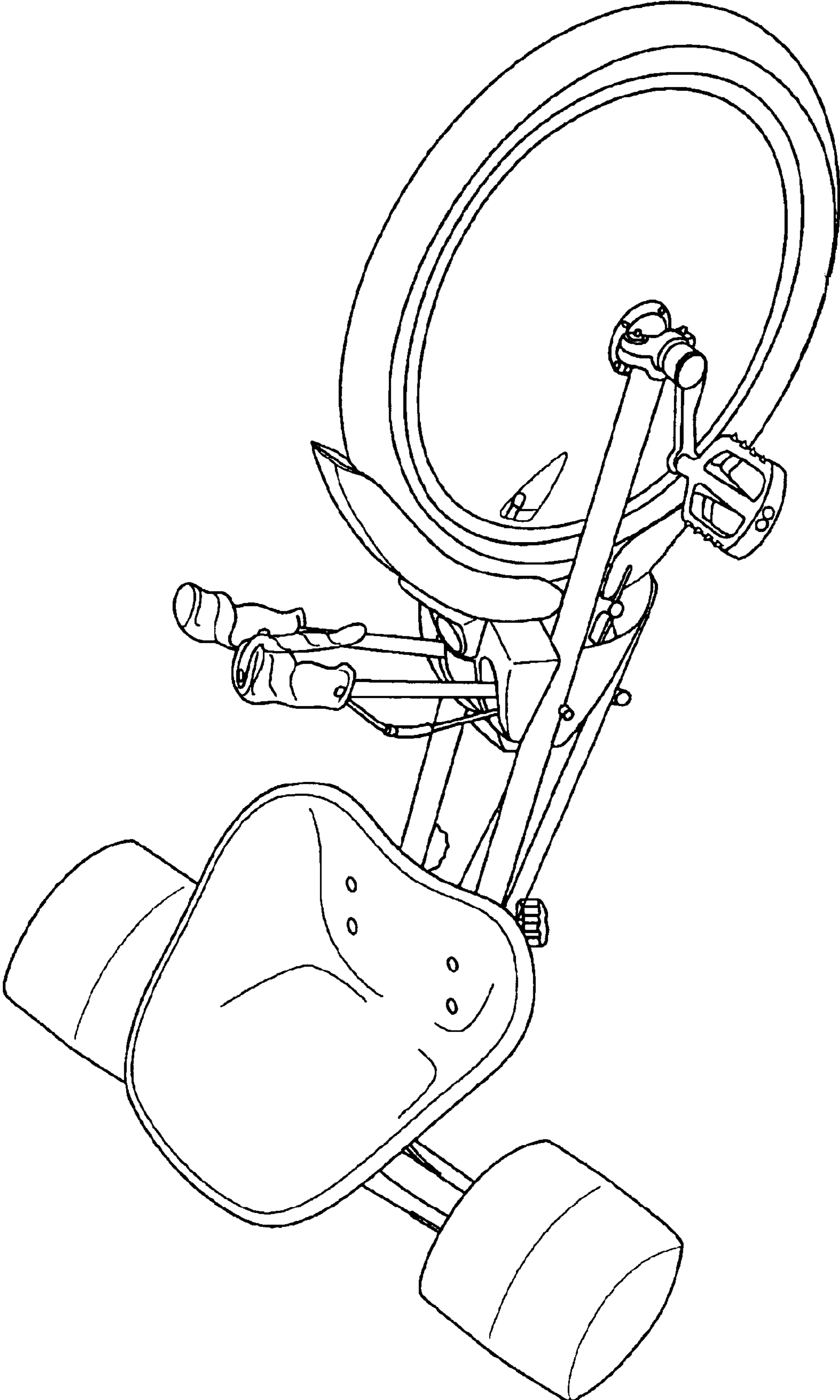

FIG. 1

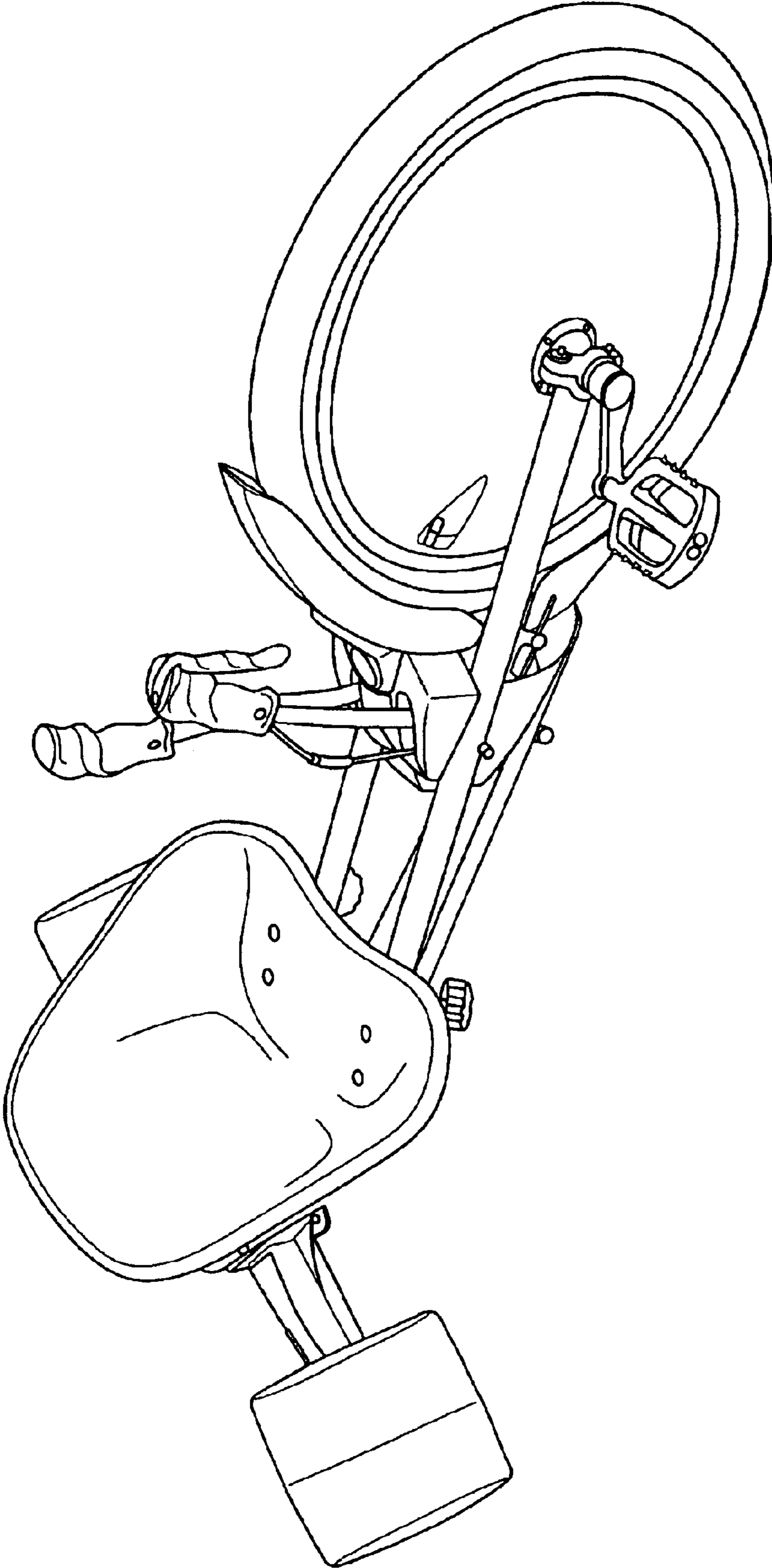

FIG. 2

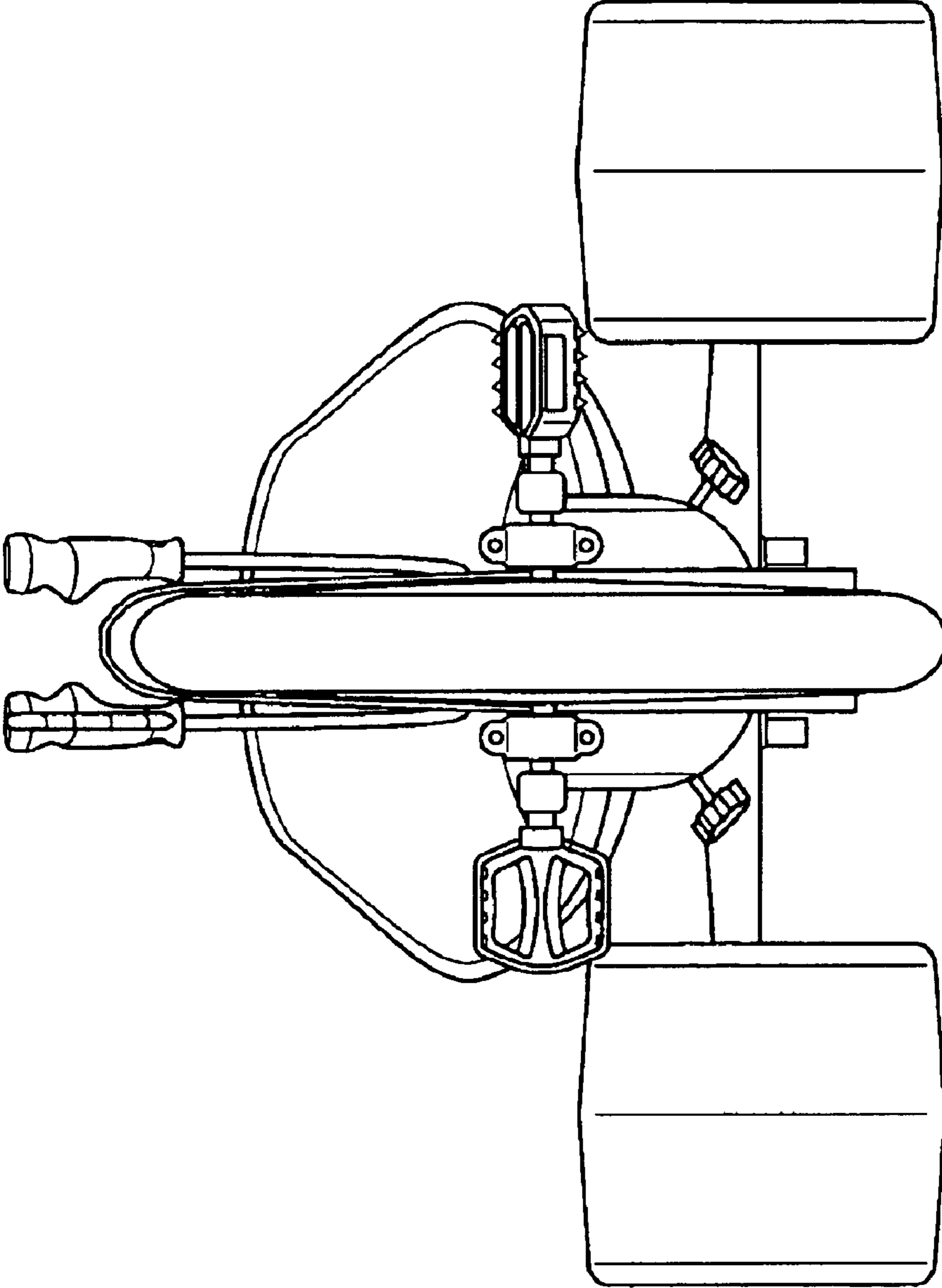

FIG. 3

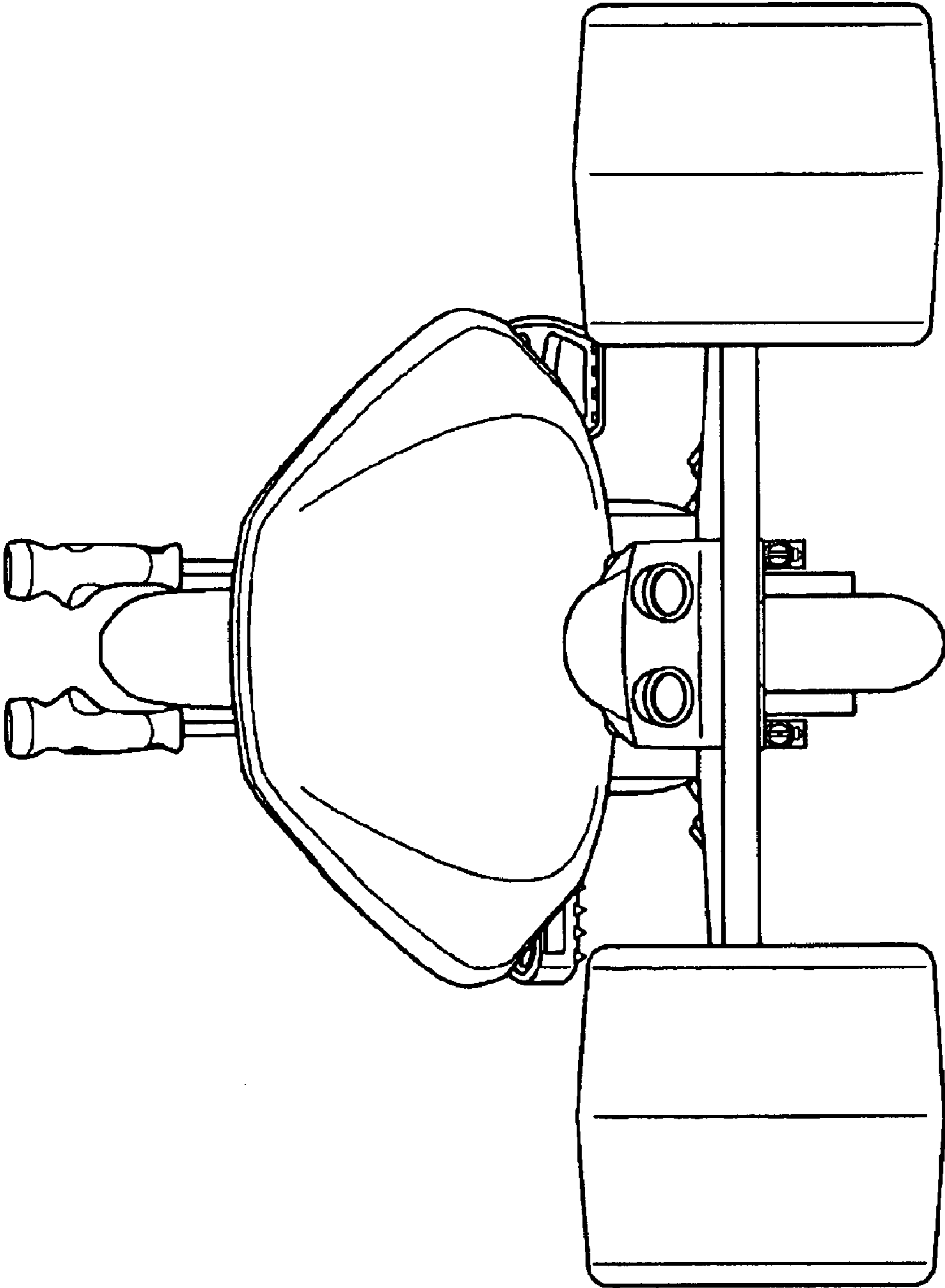

FIG. 4

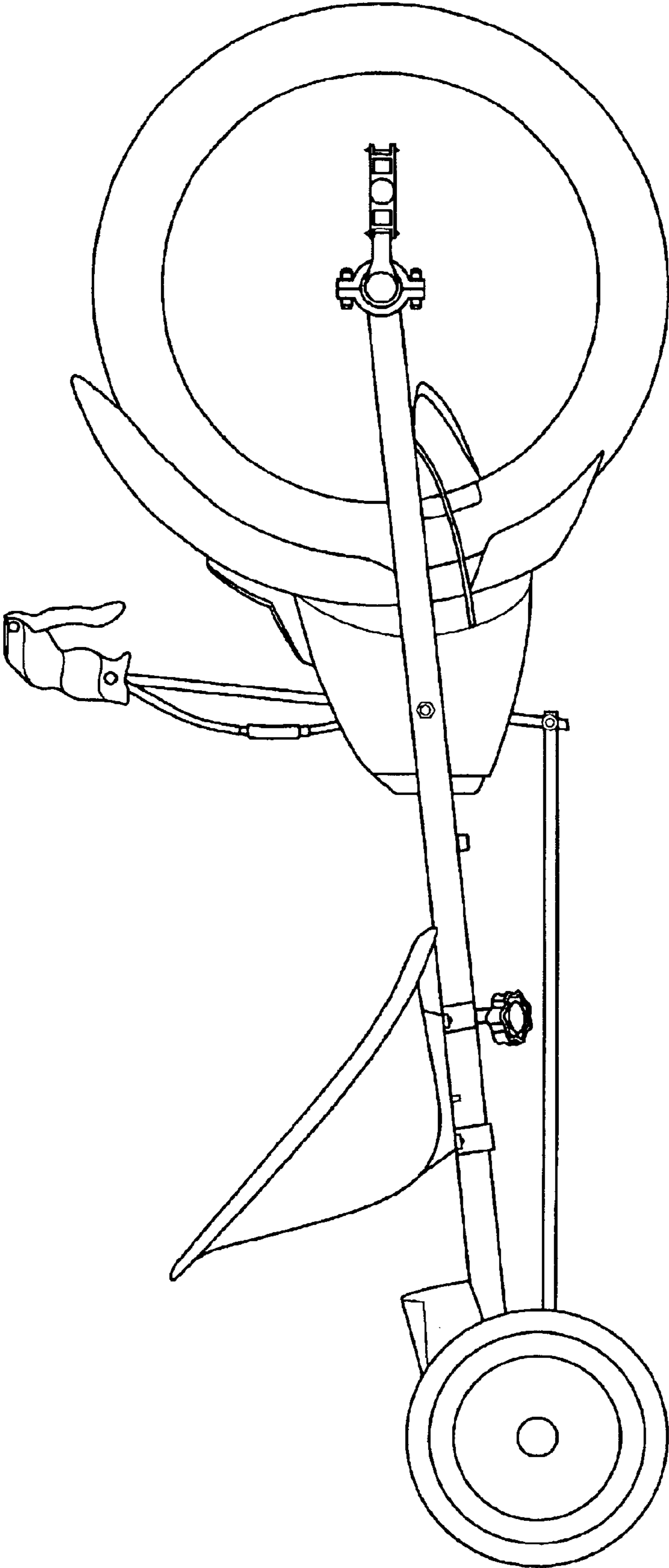

FIG. 5

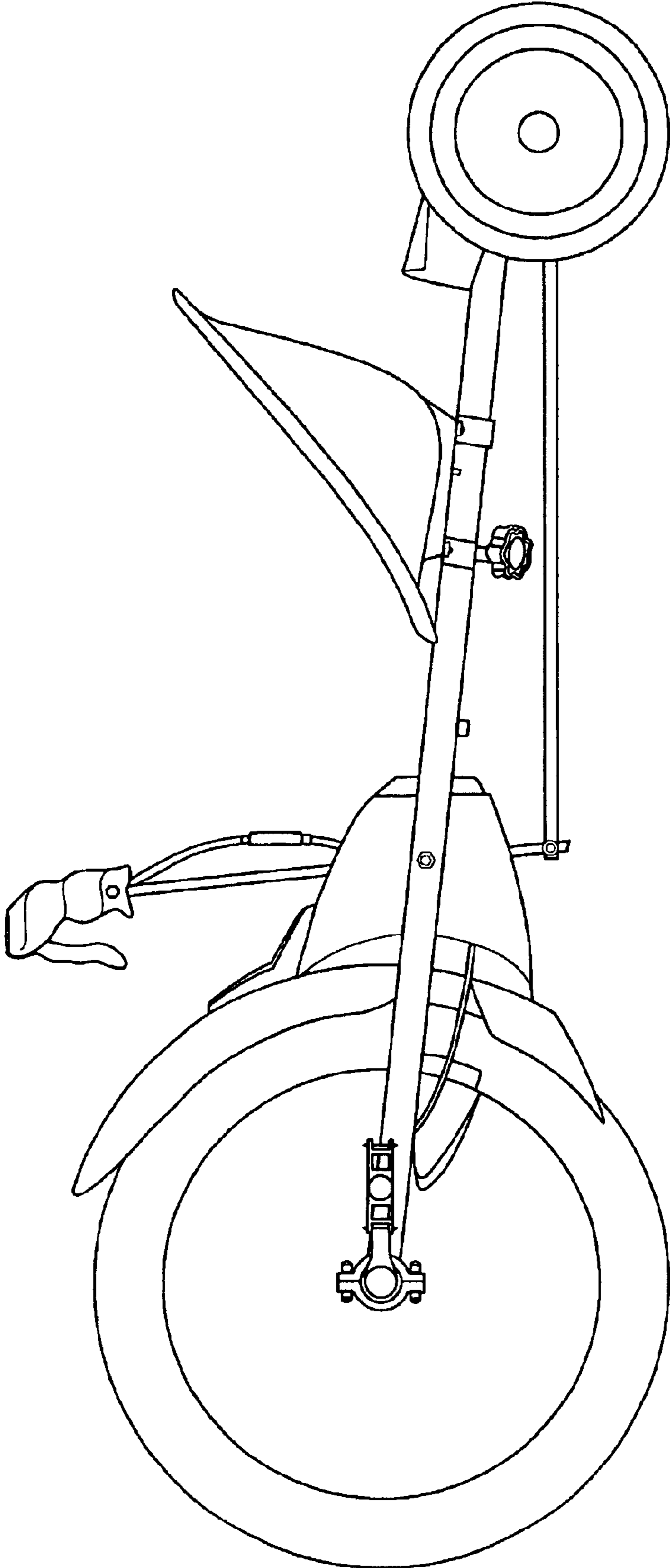

FIG. 6

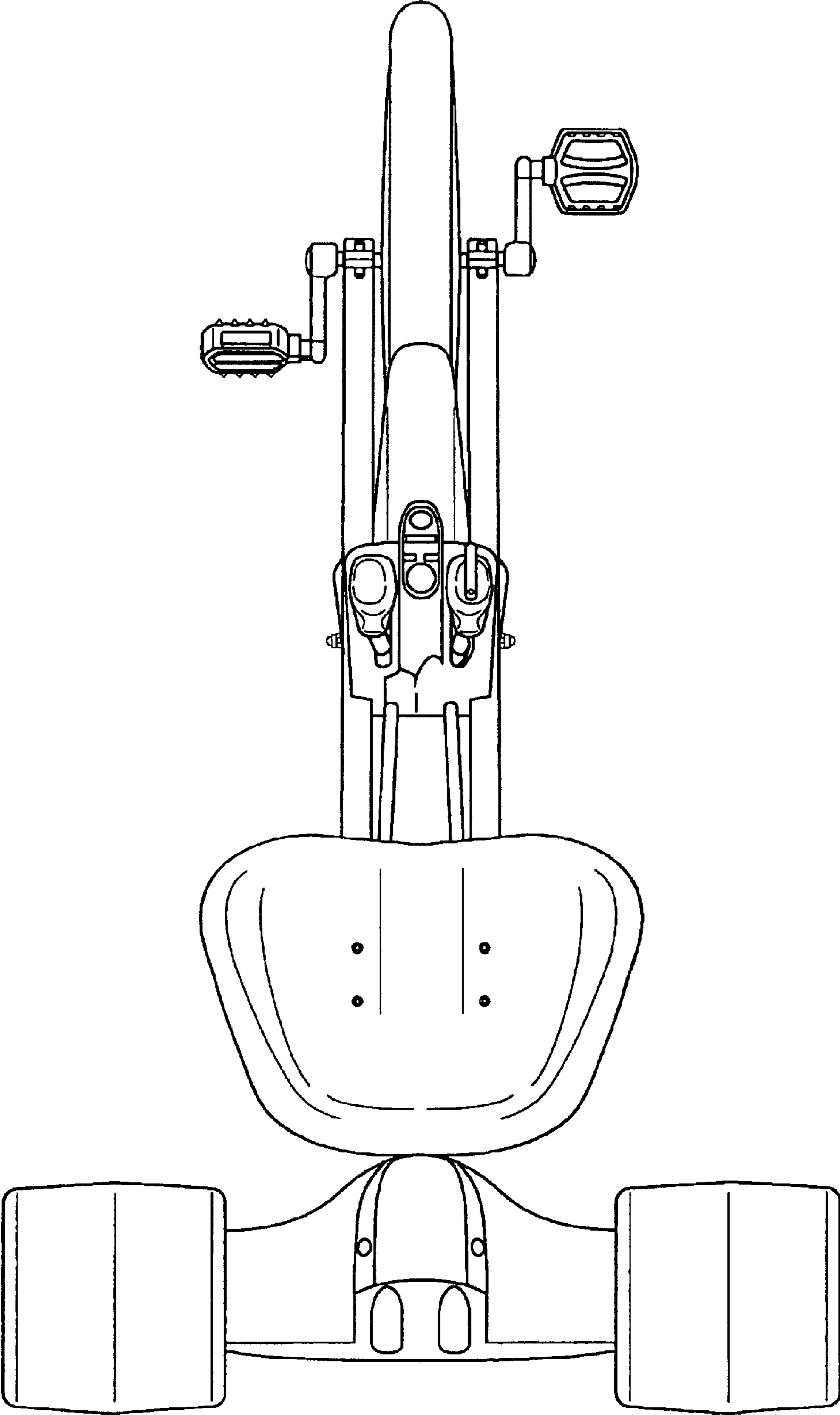

FIG. 7

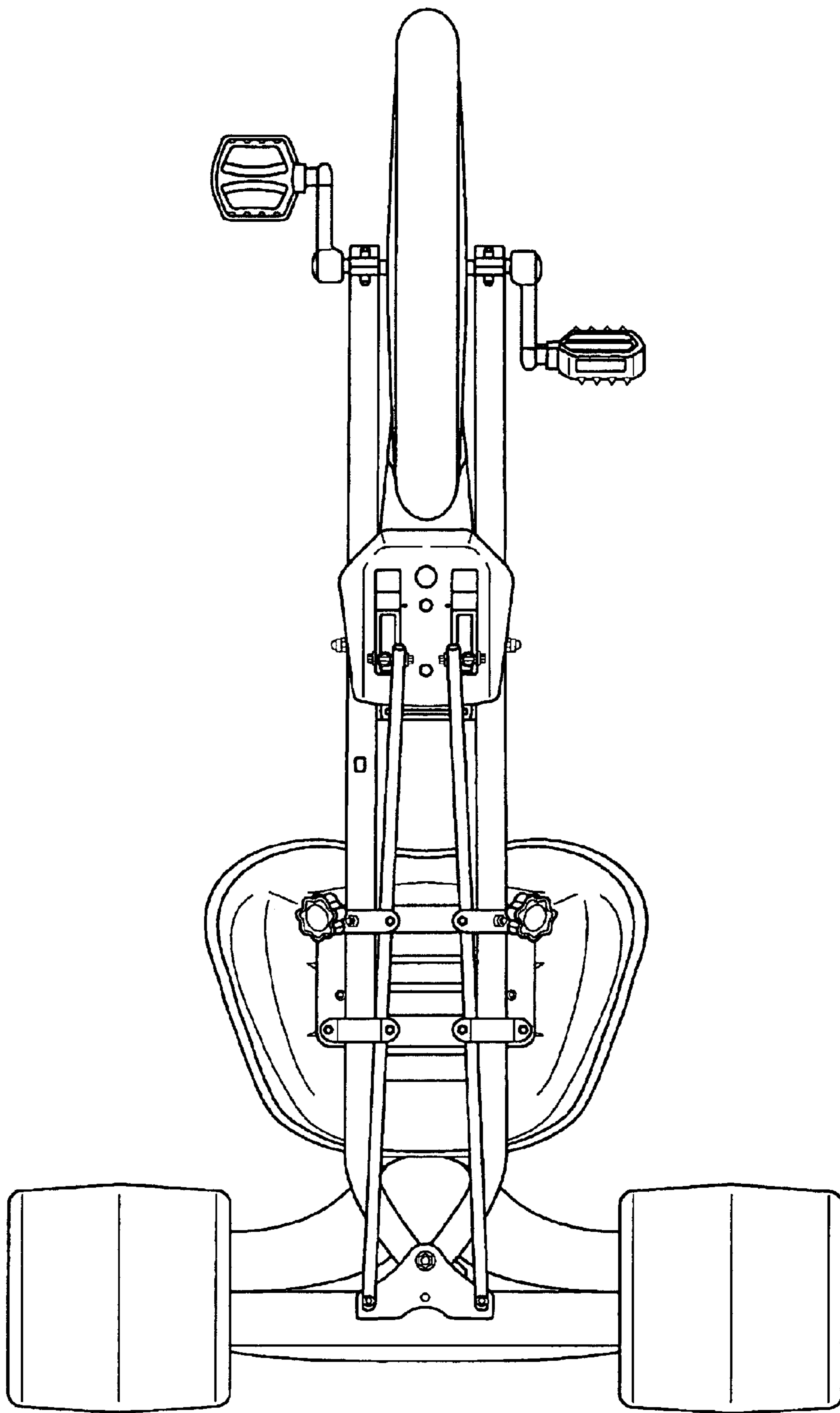

FIG. 8