

US00D493366S1

(12) **United States Design Patent**
Rackwitz

(10) **Patent No.:** **US D493,366 S**
(45) **Date of Patent:** **** Jul. 27, 2004**

(54) **NOZZLE ASSEMBLY**

(75) **Inventor:** **Ingo Rackwitz, Steinau (DE)**

(73) **Assignee:** **Societe des Produits Nestle S.A., Vevey (CH)**

(**) **Term:** **14 Years**

(21) **Appl. No.:** **29/180,837**

(22) **Filed:** **May 1, 2003**

(30) **Foreign Application Priority Data**

Nov. 28, 2002 (CH) 129102

(51) **LOC (7) Cl.** **09-07**

(52) **U.S. Cl.** **D9/435; D9/436; D9/443; D9/447; D9/448; D9/449**

(58) **Field of Search** **D9/435, 436, 443, D9/447, 448, 449, 499, 434; 222/153.11, 402.11, 402.13, 402.15, 1; 215/399**

(56) **References Cited**

U.S. PATENT DOCUMENTS

2,941,700	A	6/1960	Gable	
2,954,903	A	10/1960	Collins	
D189,323	S	* 11/1960	Epstein D9/434
D194,890	S	* 3/1963	Marler D9/443
3,249,261	A	5/1966	Benediktson	
D230,140	S	* 1/1974	Schimke D9/443
4,826,054	A	5/1989	Frutin	
5,040,705	A	8/1991	Snell	
5,553,755	A	9/1996	Bonewald et al.	
5,823,387	A	* 10/1998	Manadanas et al. 222/1
6,340,103	B1	1/2002	Scheindel et al.	
6,474,510	B2	11/2002	Frutin	
D471,811	S	* 3/2003	Lehnert D9/447

* cited by examiner

Primary Examiner—Louis S. Zarfes
Assistant Examiner—Gregory Andoll

(57) **CLAIM**

The ornamental design for a nozzle assembly, as shown and described.

DESCRIPTION

FIG. 1 is a first perspective view of the nozzle assembly apparatus of the invention;
 FIG. 2 is a top view of a lever used in the nozzle assembly apparatus illustrated in FIG. 1;
 FIG. 3 is a side view of the lever illustrated in FIG. 2;
 FIG. 4 is a front view of the lever illustrated in FIG. 2;
 FIG. 5 is a rear view of the lever illustrated in FIG. 2;
 FIG. 6 is a bottom view of the lever illustrated in FIG. 2;
 FIG. 7 is a second perspective view of the nozzle assembly apparatus of the invention shown in an alternate position;
 FIG. 8 is a perspective view of the lever illustrated in FIG. 2, shown attached to an attachment ring used in the invention;
 FIG. 9 is a top view of the lever and attachment ring illustrated in FIG. 8;
 FIG. 10 is a side view of the lever and attachment ring illustrated in FIG. 8;
 FIG. 11 is a front view of the lever and attachment ring illustrated in FIG. 8;
 FIG. 12 is a rear view of the lever and attachment ring illustrated in FIG. 8;
 FIG. 13 is a perspective view of the underside of the lever and attachment ring illustrated in FIG. 8;
 FIG. 14 is a perspective view of a nozzle assembly used in the invention;
 FIG. 15 is a top view of the nozzle assembly illustrated in FIG. 14;
 FIG. 16 is a first side view of the nozzle assembly illustrated in FIG. 14;
 FIG. 17 is a second side view of the nozzle assembly illustrated in FIG. 14; and,
 FIG. 18 is a bottom view of the nozzle assembly illustrated in FIG. 14.

The broken lines in the Figures are for illustrative purposes only and form no part of the claimed design.

1 Claim, 3 Drawing Sheets

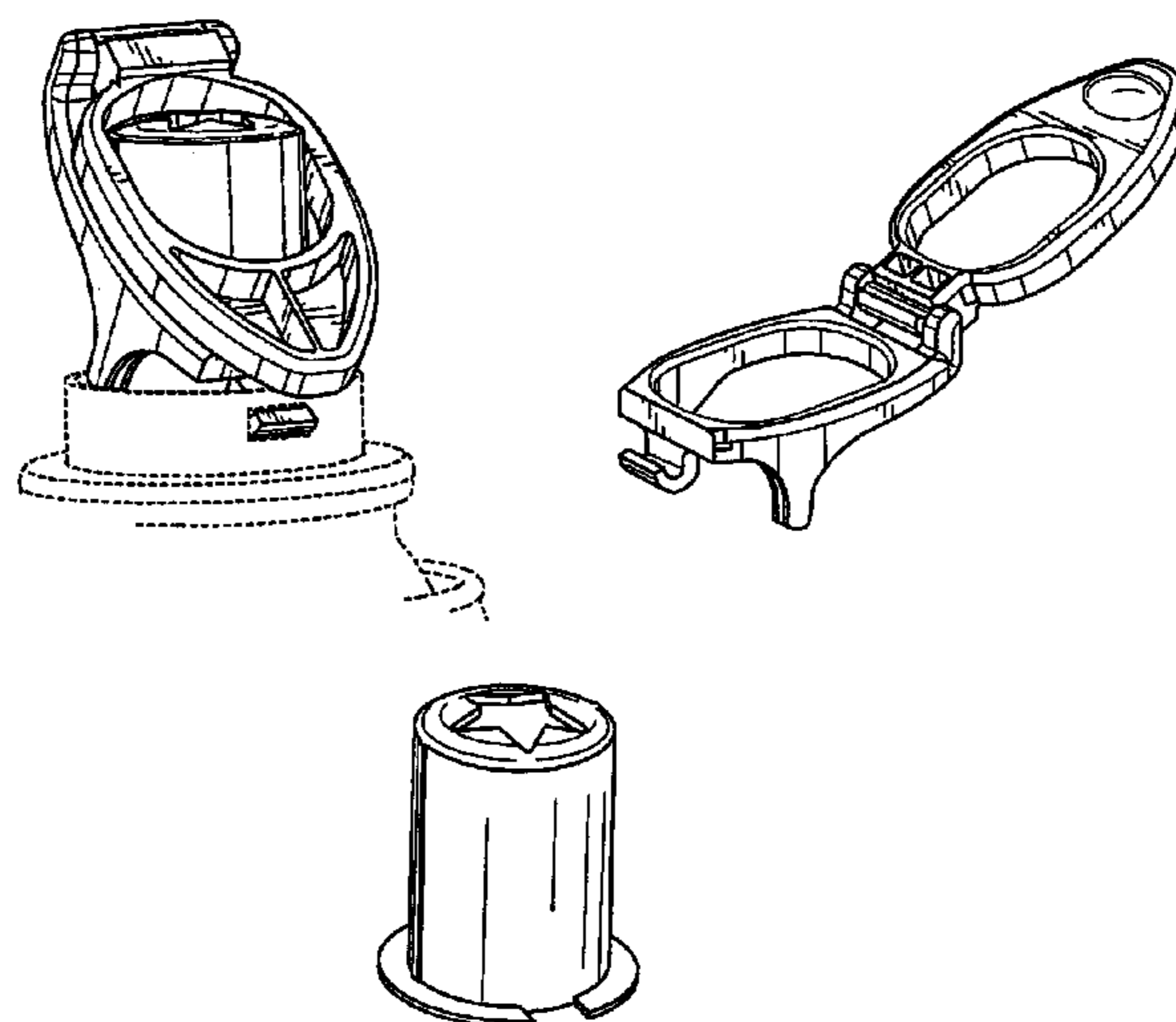

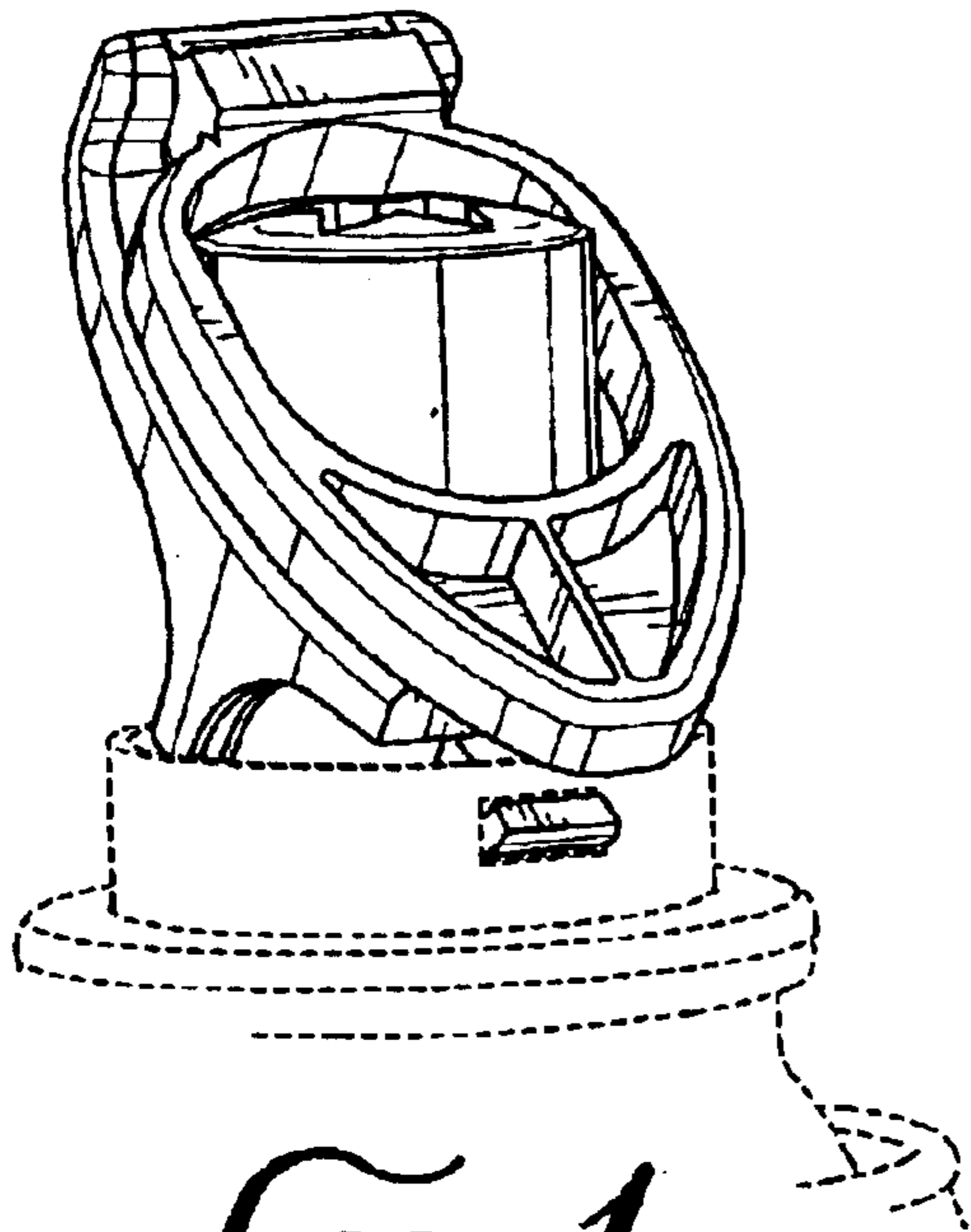

FIG. 1

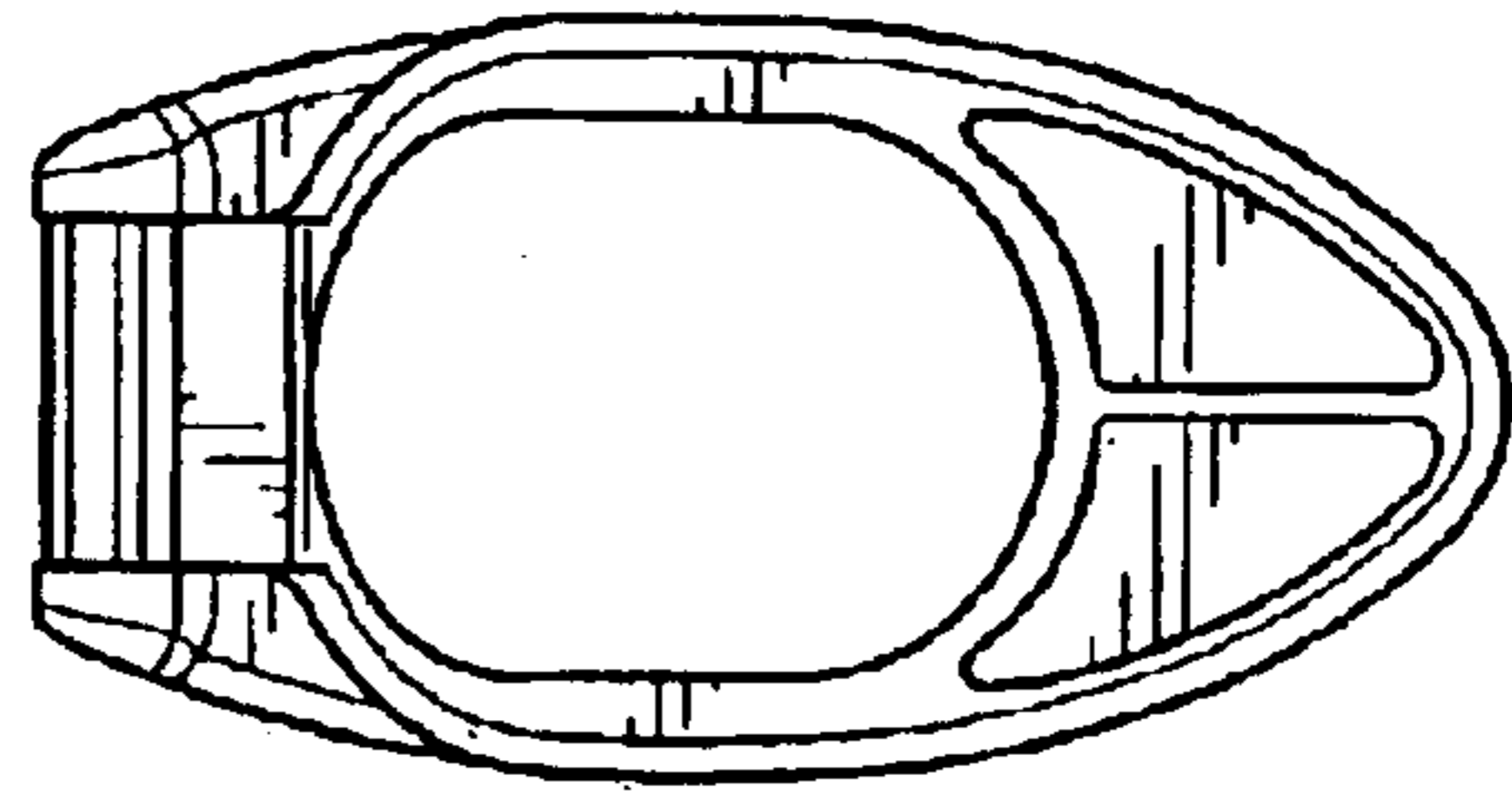

FIG. 2

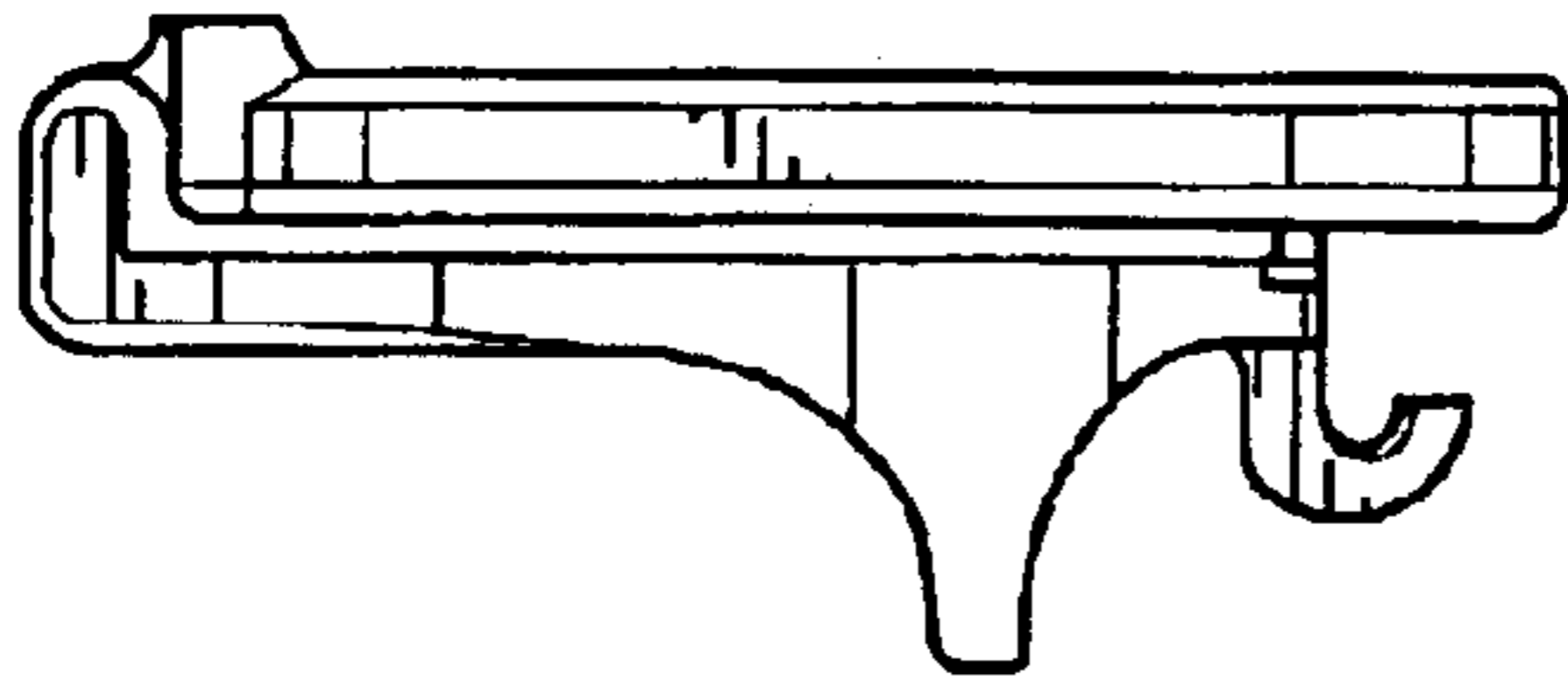

FIG. 3

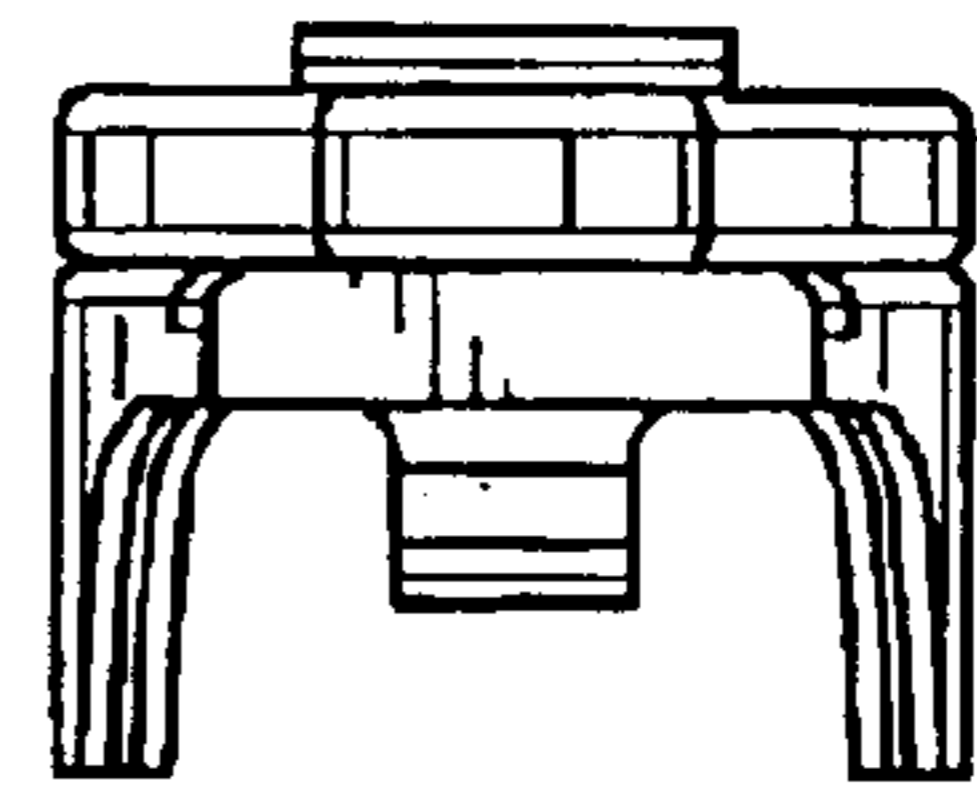

FIG. 4

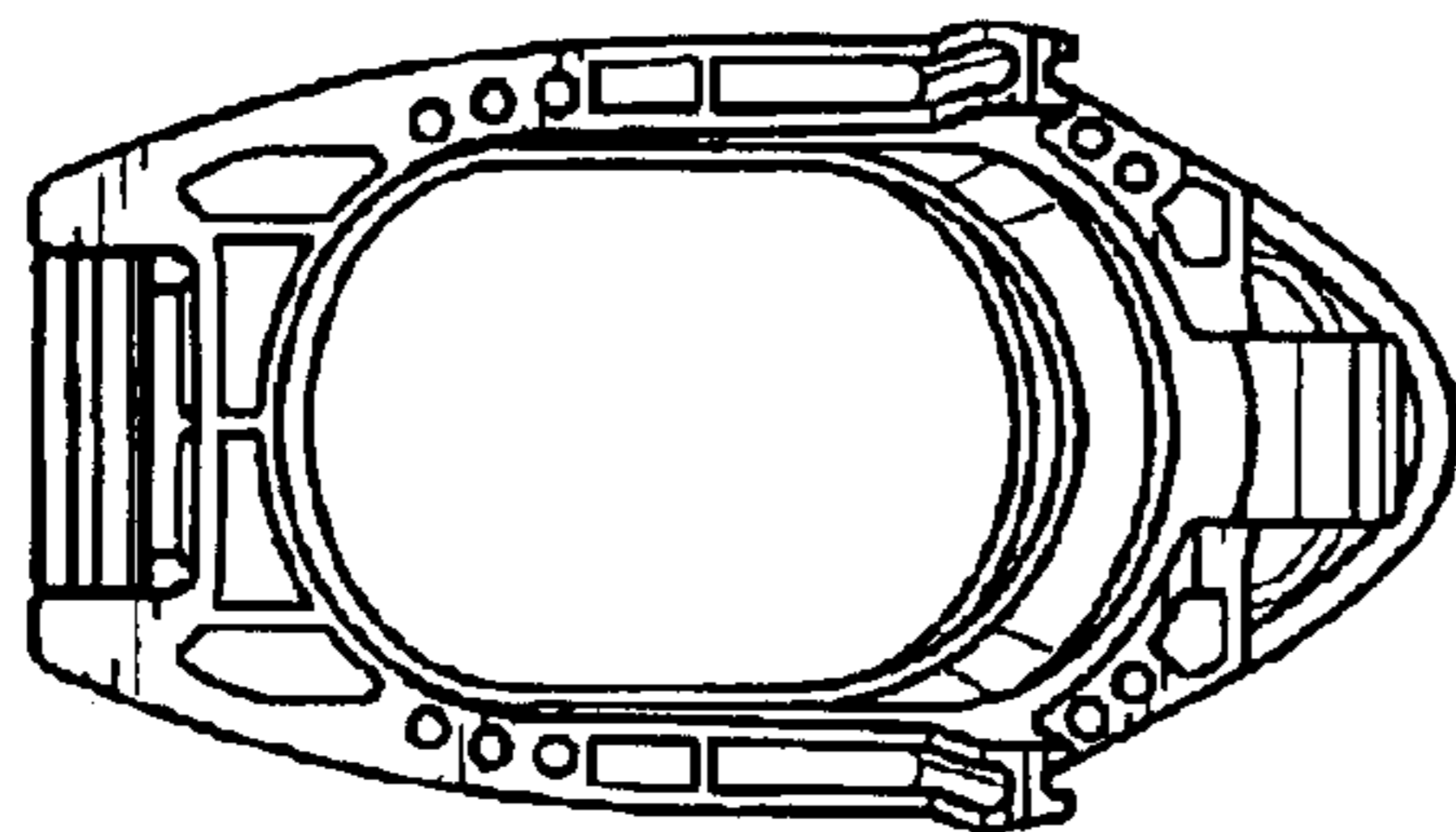

FIG. 6

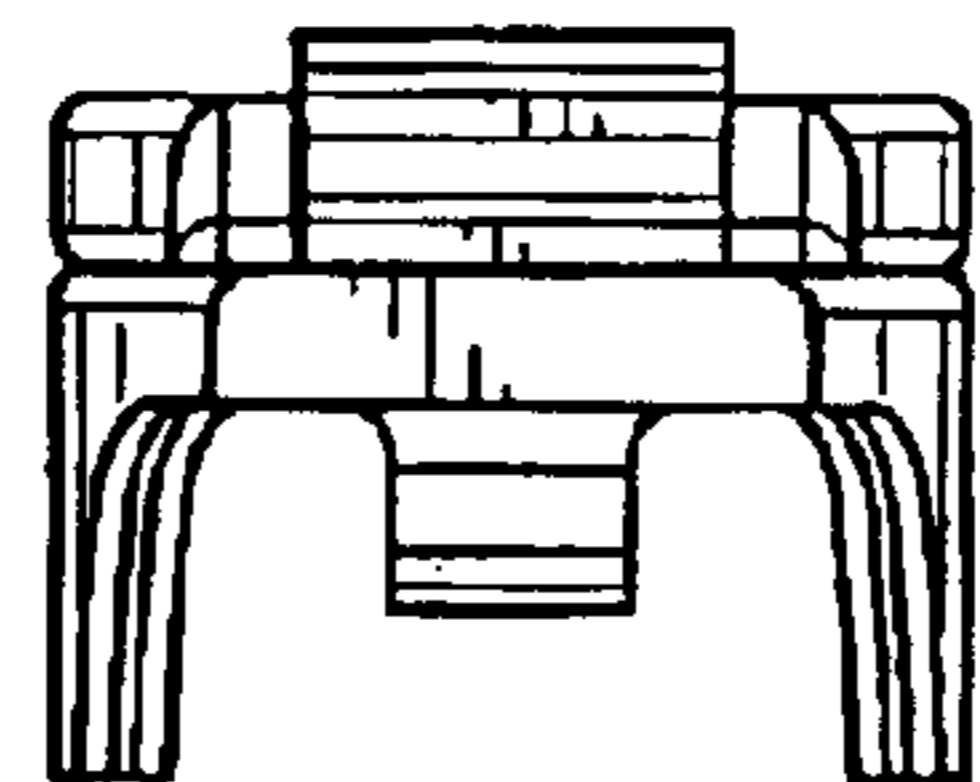

FIG. 5

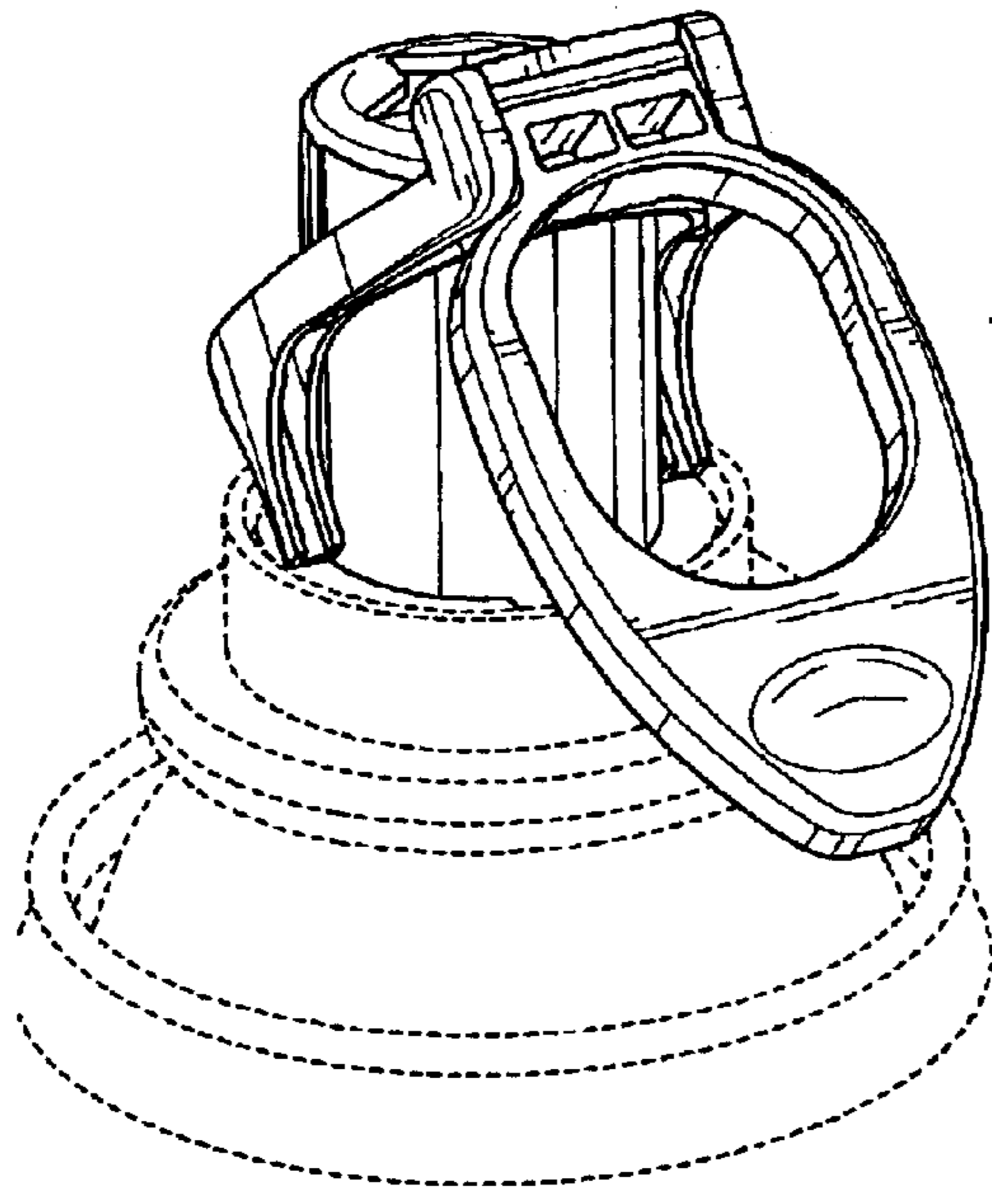

FIG. 7

FIG. 8

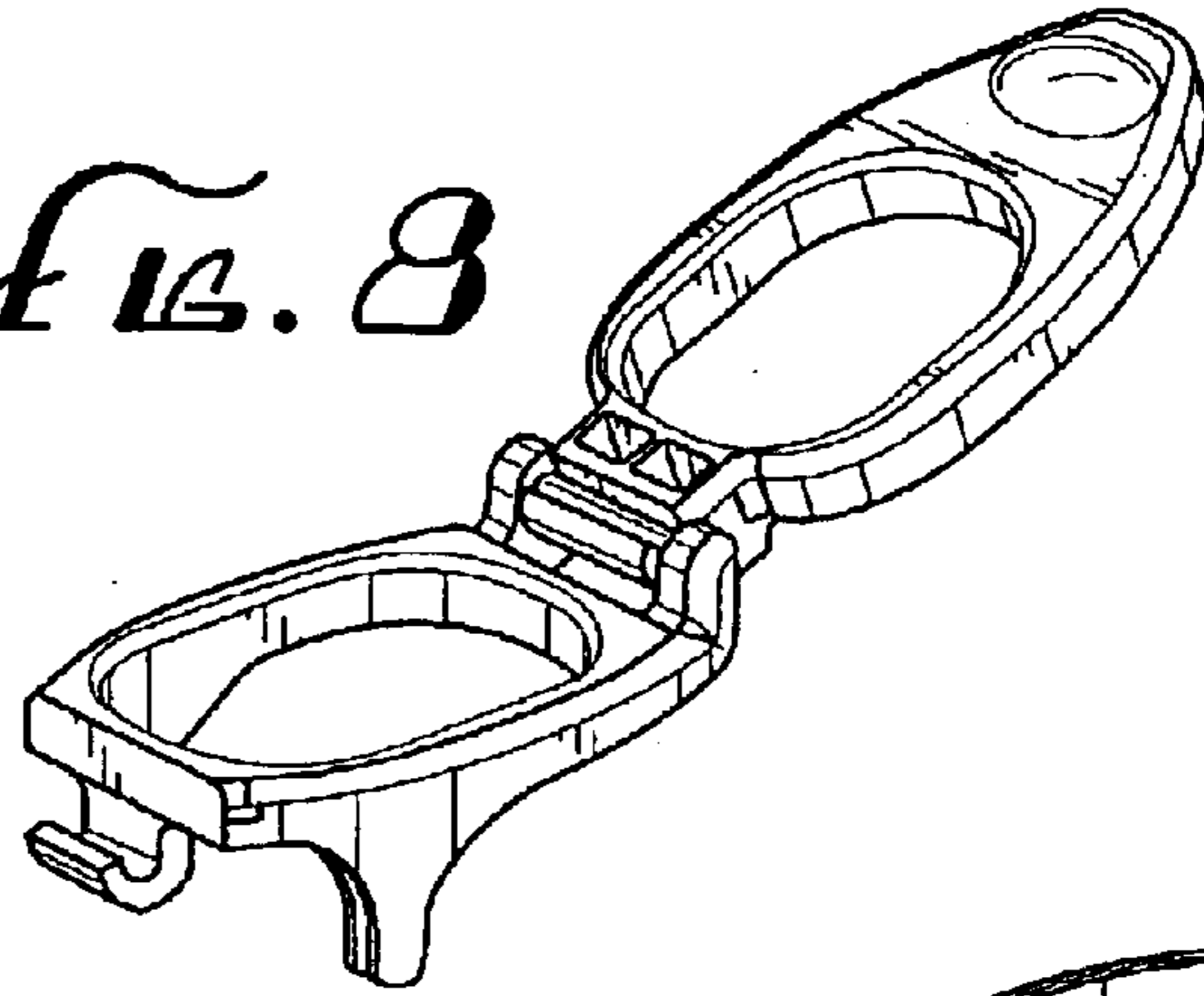

FIG. 9

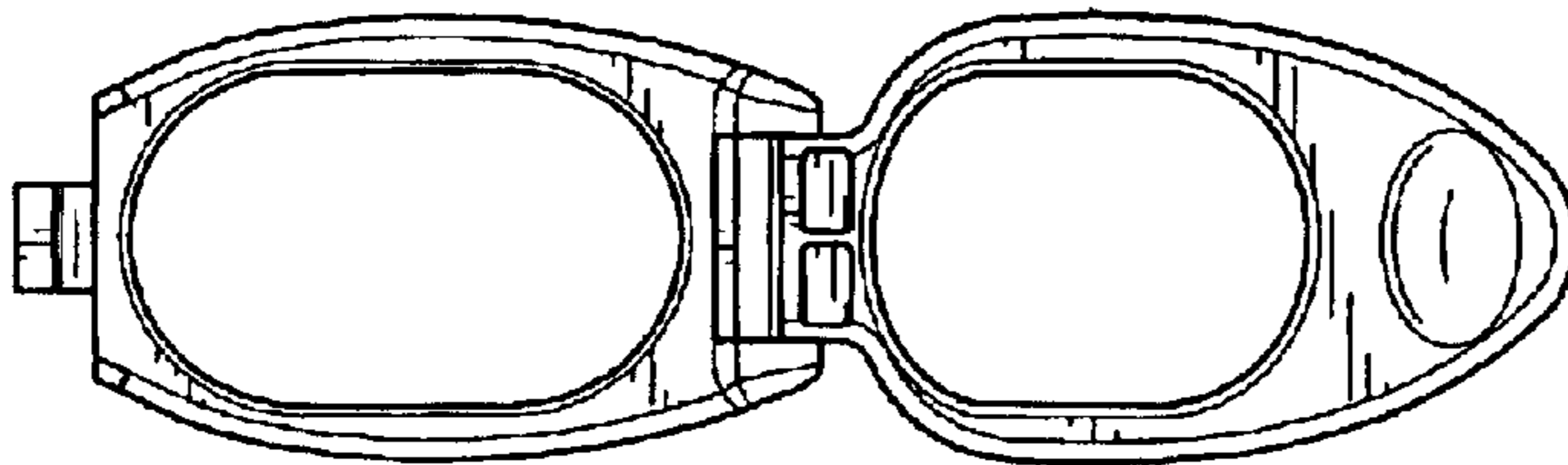

FIG. 13

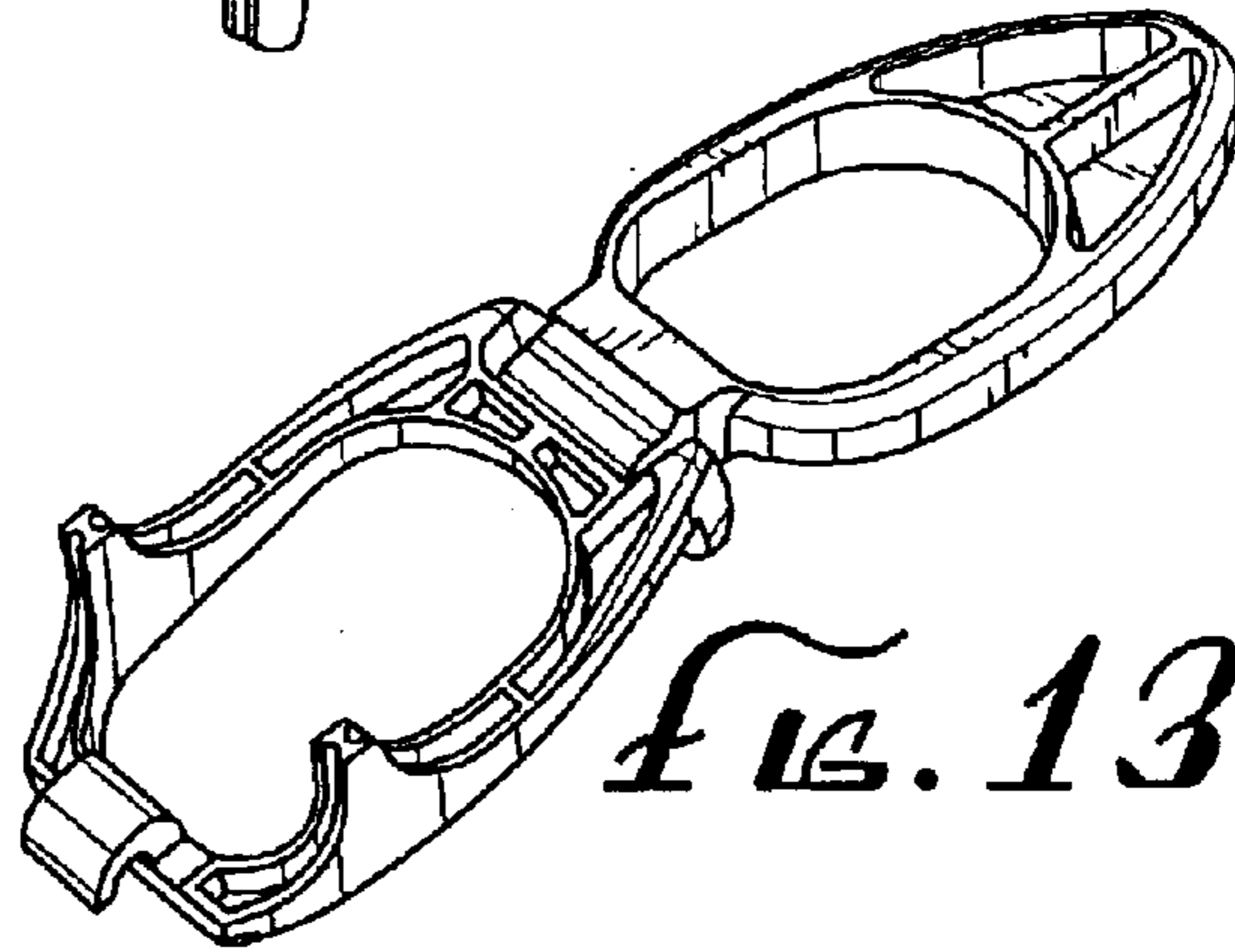

FIG. 11

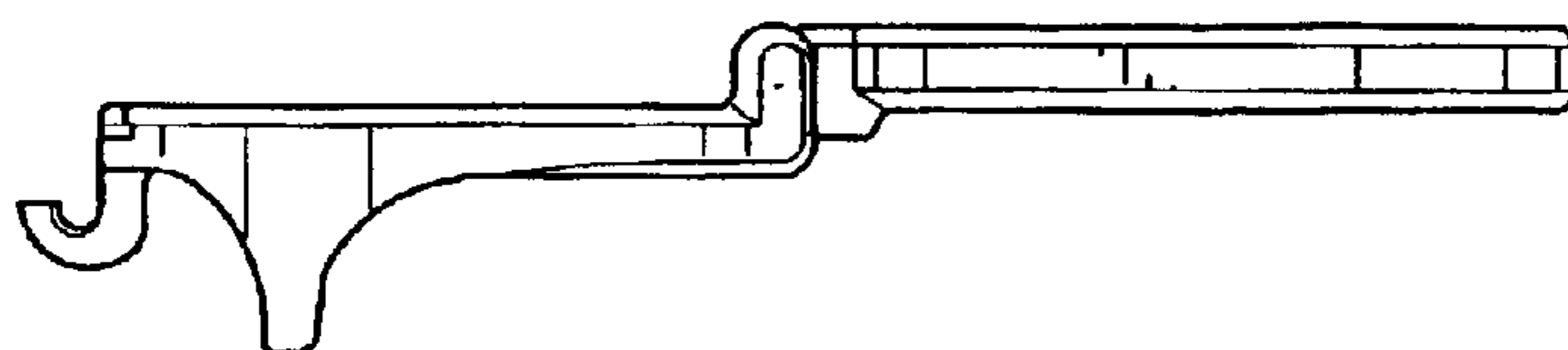
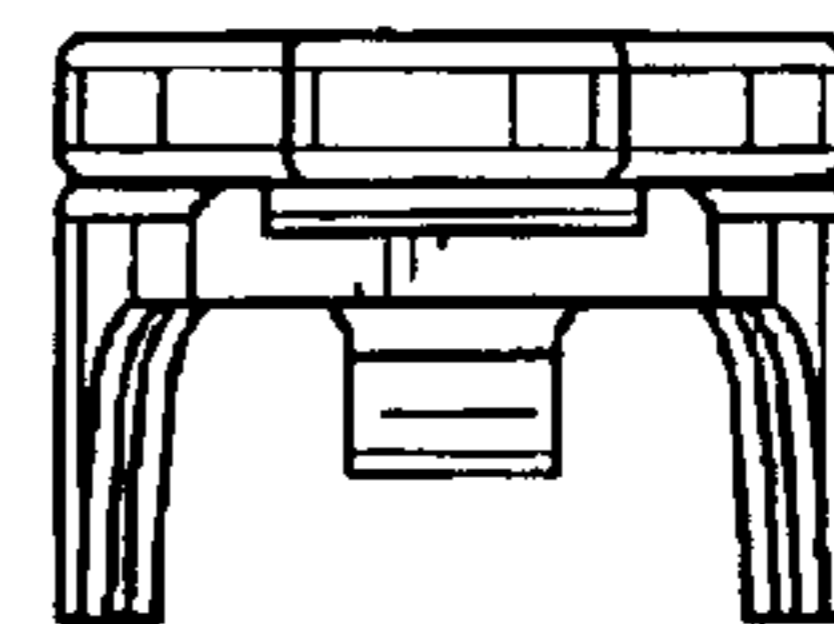

FIG. 10

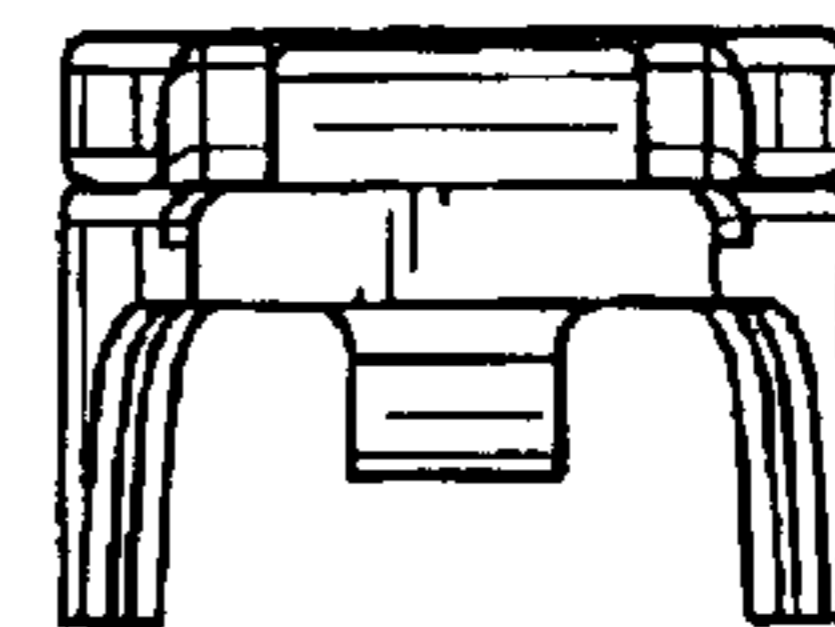

FIG. 12

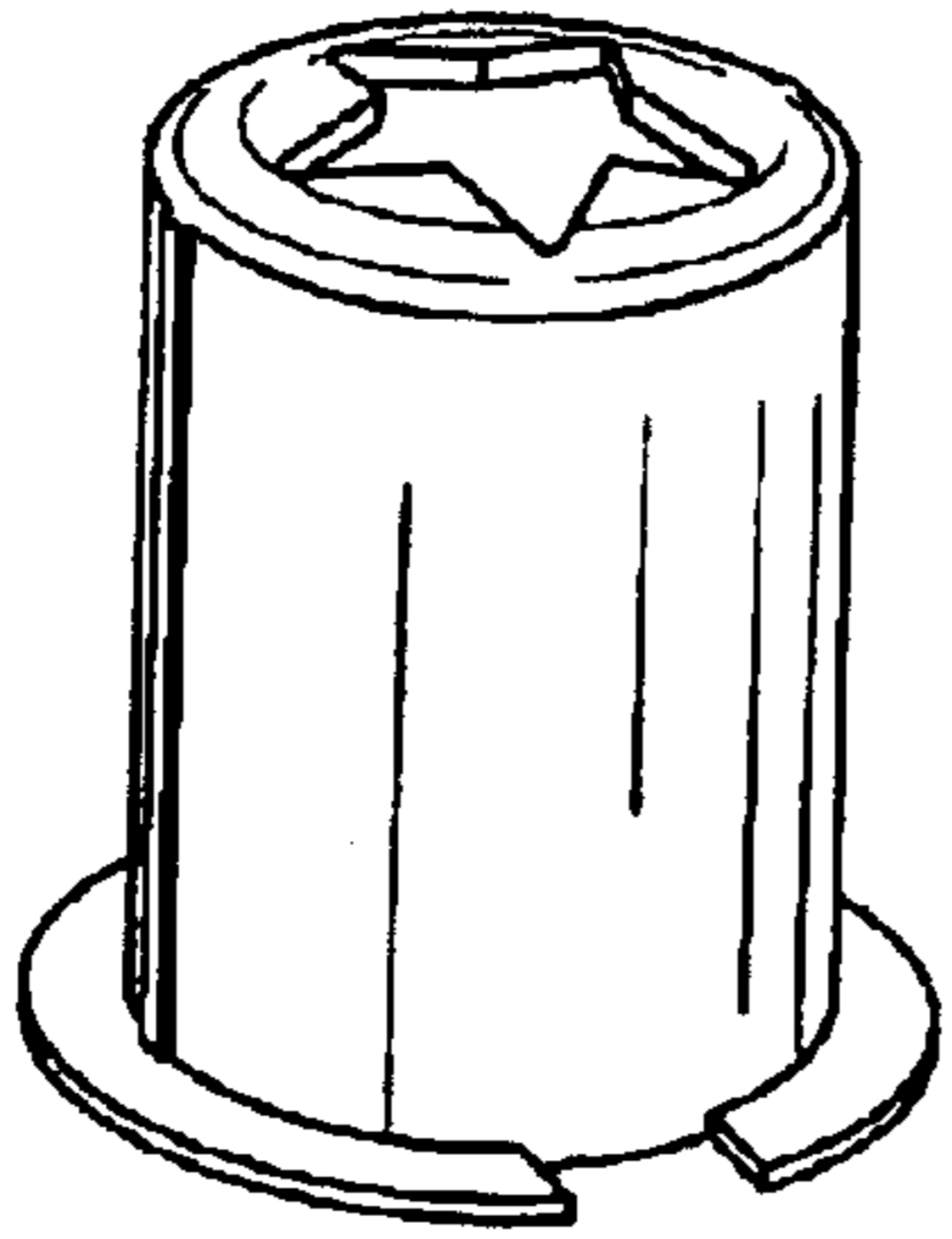

FIG. 14

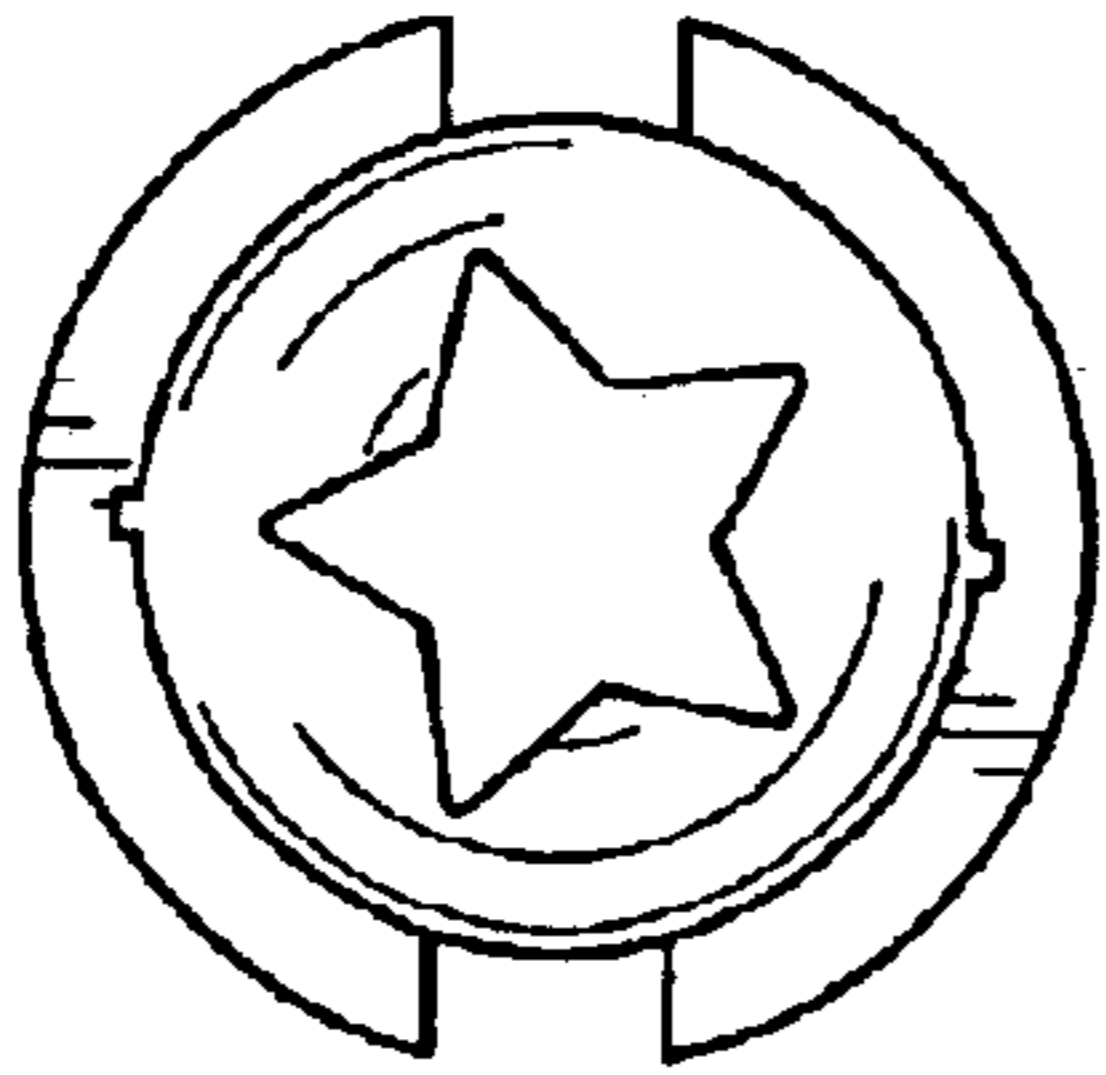

FIG. 15

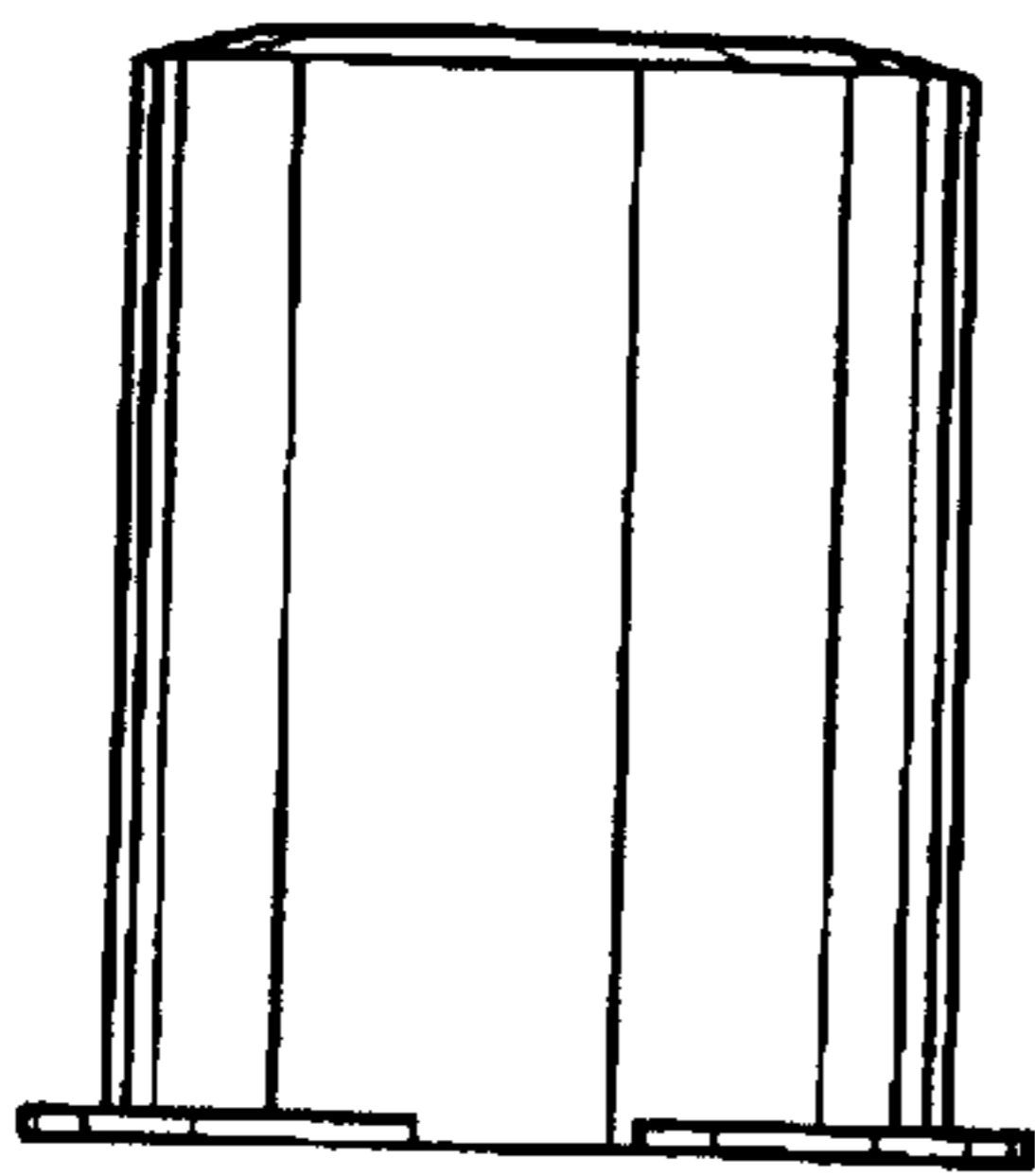

FIG. 16

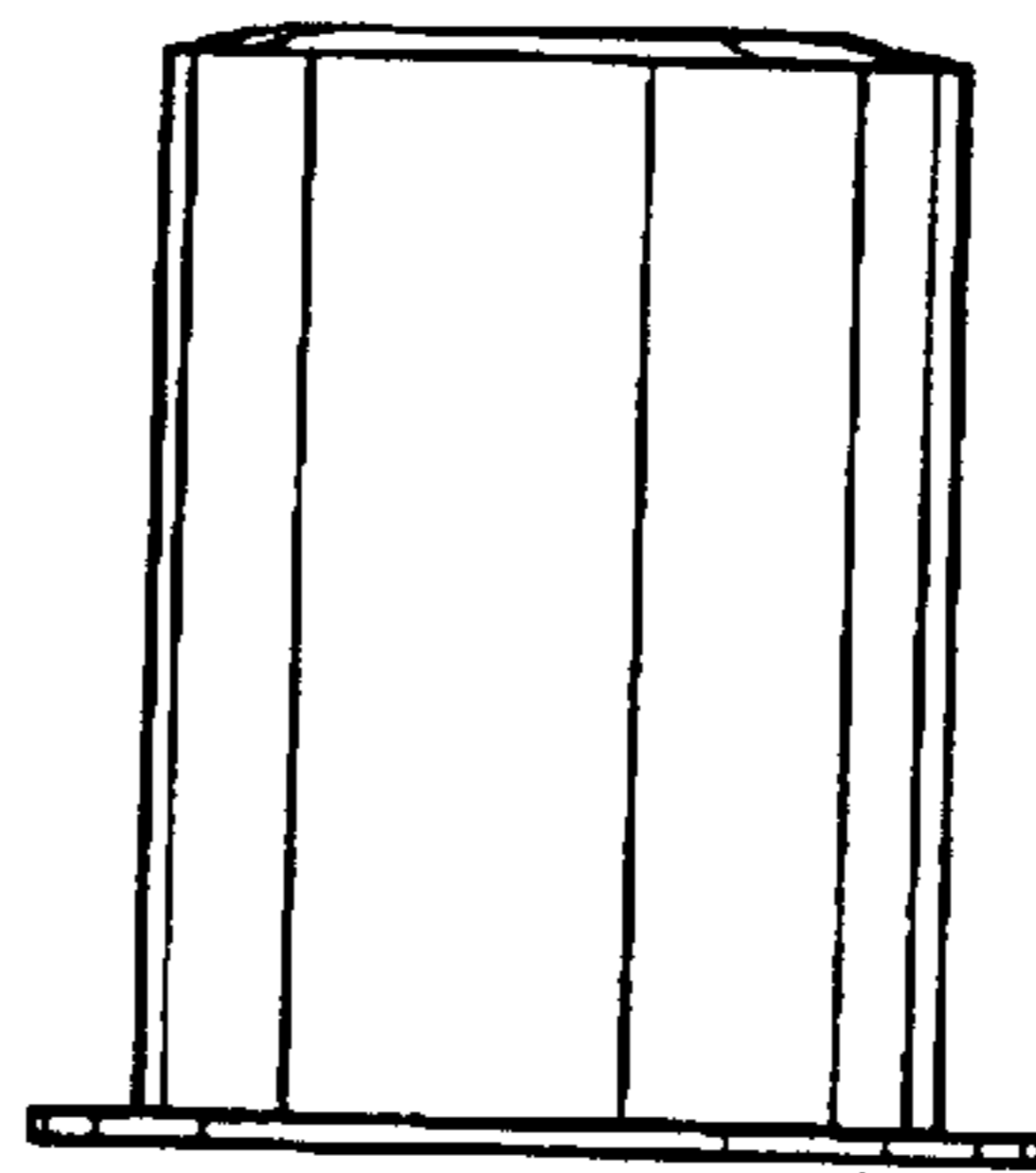

FIG. 17

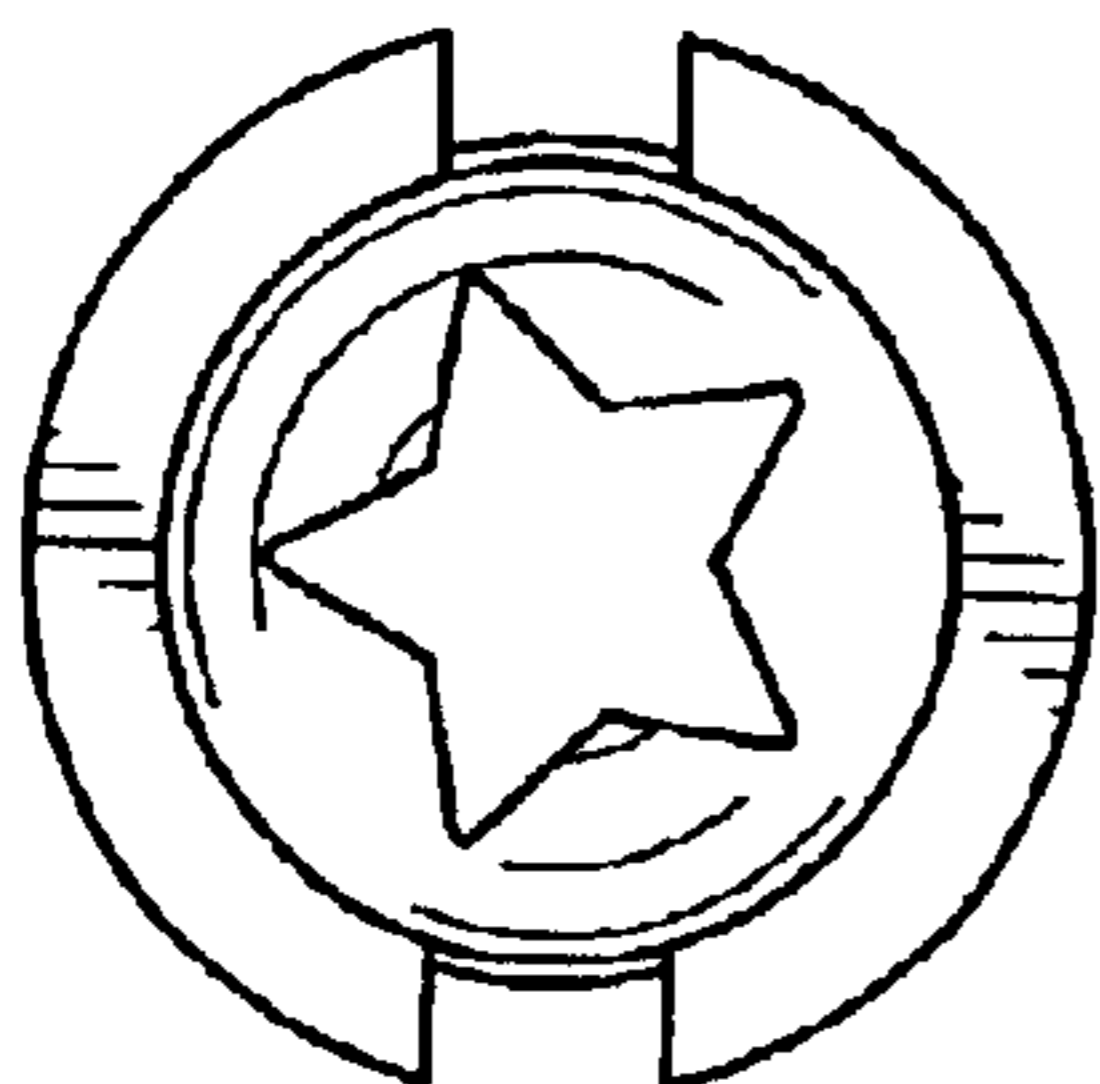

FIG. 18