

US00D493294S1

(12) **United States Design Patent** (10) **Patent No.:** **US D493,294 S**
Newson (45) **Date of Patent:** **** Jul. 27, 2004**

(54) **SEAT MODULE**

(75) **Inventor:** **Marc Andrew Newson, London (GB)**

(73) **Assignee:** **Qantas Airways Limited (AU)**

(**) **Term:** **14 Years**

(21) **Appl. No.:** **29/178,542**

(22) **Filed:** **Mar. 24, 2003**

(30) **Foreign Application Priority Data**

Sep. 24, 2002 (AU) 2967/2002

(51) **LOC (7) Cl.** **06-01**

(52) **U.S. Cl.** **D6/356**

(58) **Field of Search** D6/334, 335, 336,
D6/356, 360, 361, 367, 381, 500-502;
D12/195, 345; 297/68, 72, 84, 88, 90, 232,
244, 341, 342, 354.11, 423.1, 423.2

(56) **References Cited**

U.S. PATENT DOCUMENTS

D268,973 S *	5/1983	White	D6/356
D269,652 S *	7/1983	McKean et al.	D6/356
D277,239 S *	1/1985	White	D6/356
5,628,547 A *	5/1997	Matsumiya	297/354.11
D405,275 S *	2/1999	Dryburgh et al.	D6/356
D411,922 S *	7/1999	Granados	D6/356
D421,593 S *	3/2000	Papaioannou et al.	D12/345
D439,063 S *	3/2001	Round et al.	D6/356
D443,990 S *	6/2001	Beroth	D6/356
6,412,870 B1 *	7/2002	Higgins et al.	297/342

* cited by examiner

Primary Examiner—Stacia Cadmus

Assistant Examiner—Mimosa De

(74) *Attorney, Agent, or Firm*—Knobbe, Martens, Olson & Bear LLP

(57) **CLAIM**

The ornamental design for a seat module, as shown and described.

DESCRIPTION

FIG. 1 is a front, right, side perspective view of a first embodiment of the seat module of the present design;

FIG. 2 is a top plan view of the seat module of FIG. 1;

FIG. 3 is a front elevational view of the seat module of FIG. 1;

FIG. 4 is a rear, left side perspective view of the seat module of FIG. 1;

FIG. 5 is a rear, right side perspective view of the seat module of FIG. 1;

FIG. 6 is a left side elevational view of the seat module of FIG. 1, the right side elevational view being a mirror image thereof;

FIG. 7 is a front, right side perspective view of a second embodiment of the seat module of the present design;

FIG. 8 is a top plan view of the seat module of FIG. 7;

FIG. 9 is a front elevational view of the seat module of FIG. 7;

FIG. 10 is a rear, left side perspective view of the seat module of FIG. 7;

FIG. 11 is a rear, right side perspective view of the seat module of FIG. 7; and,

FIG. 12 is a front, right side perspective view of the seat module of FIG. 1, illustrating an alternative configuration for the seat module.

1 Claim, 12 Drawing Sheets

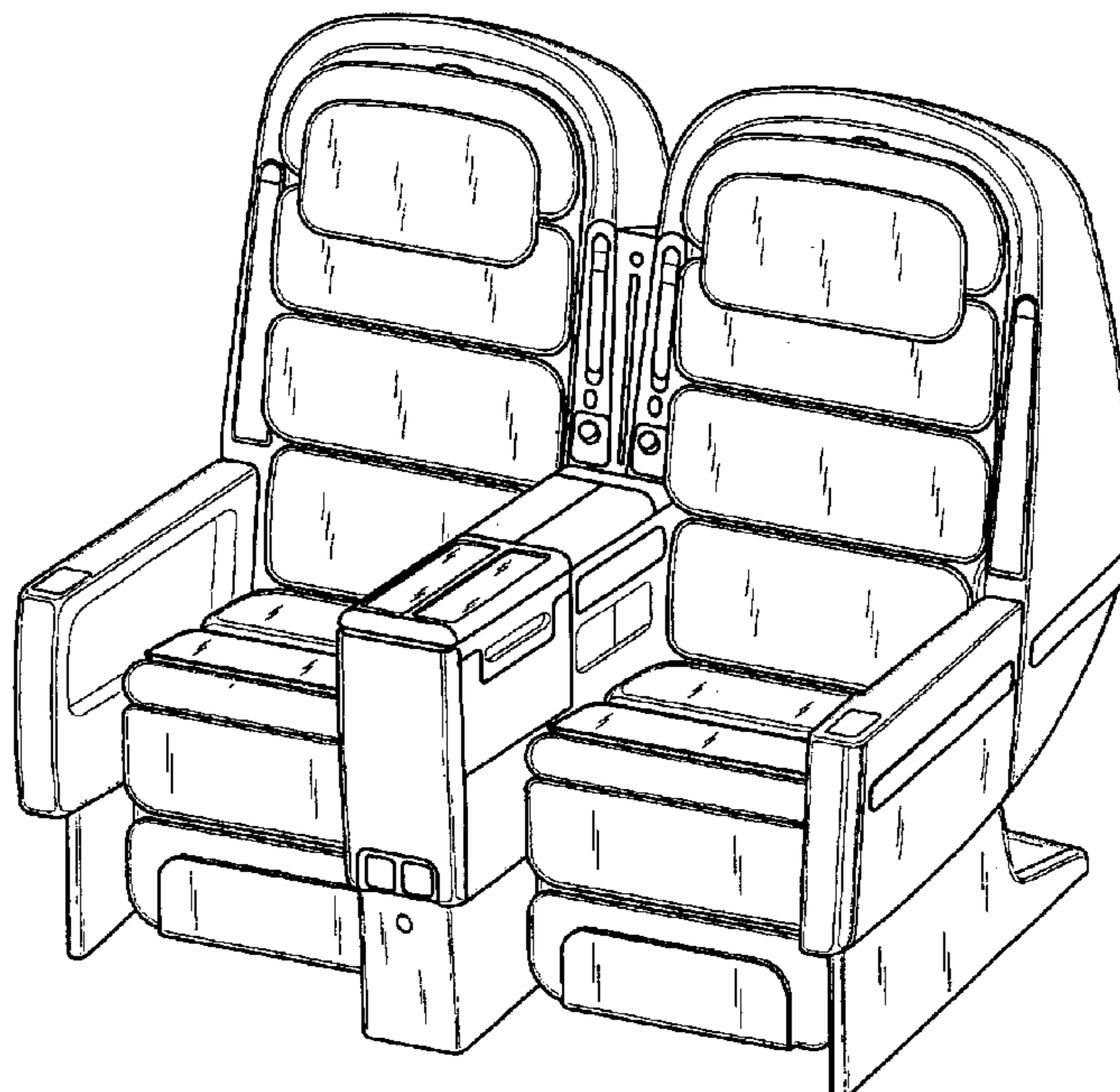

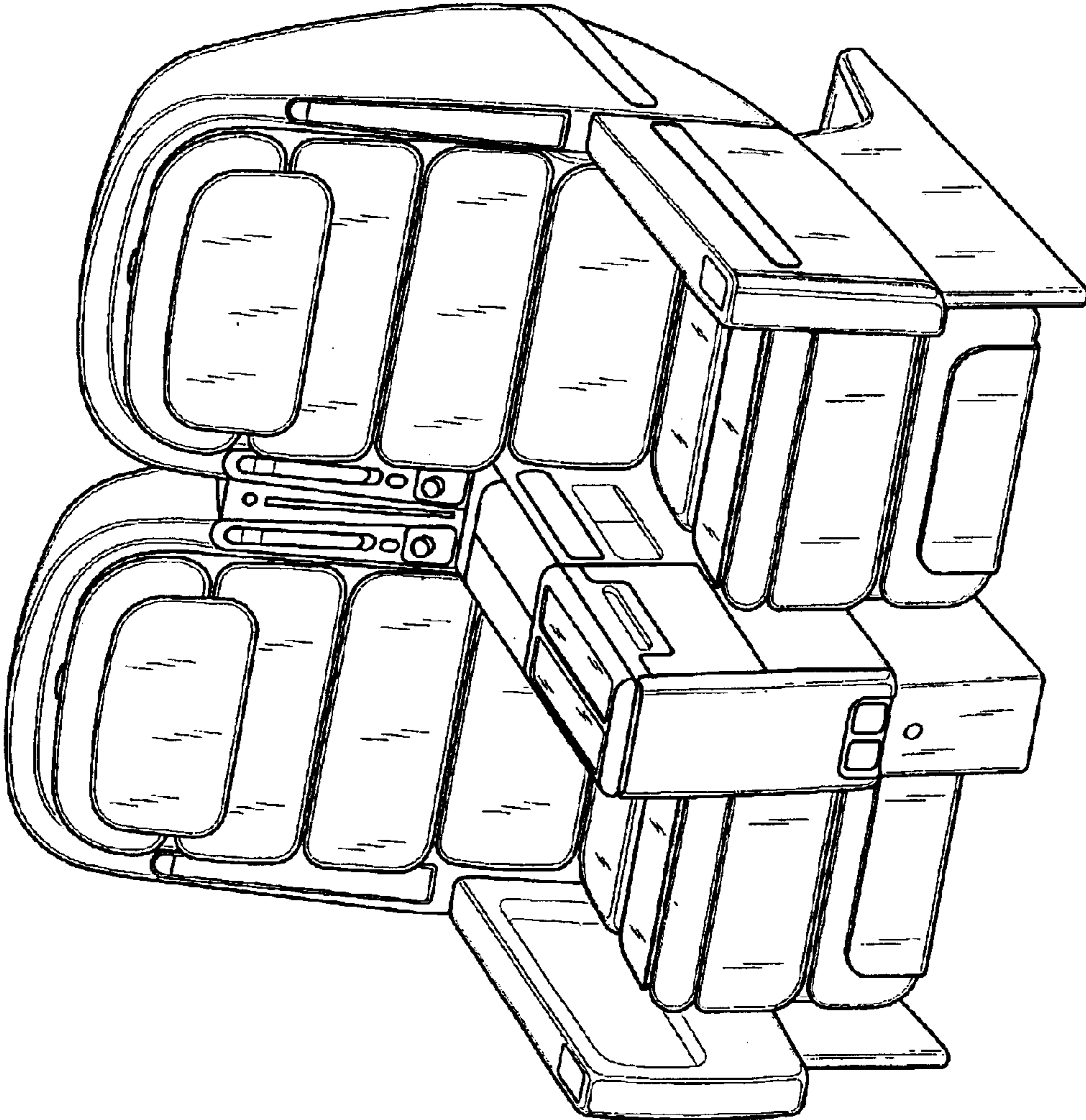

FIG. 1

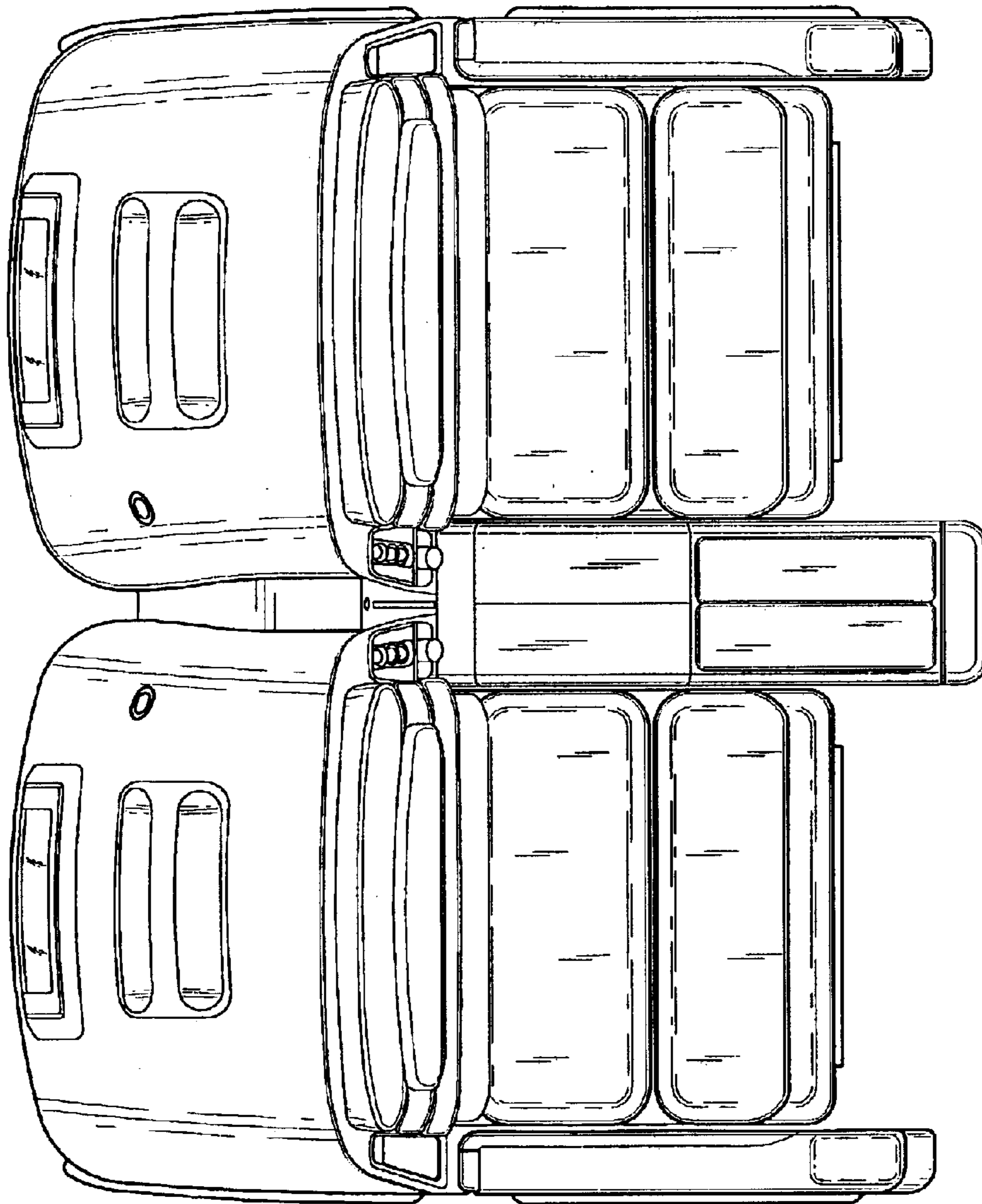

FIG. 2

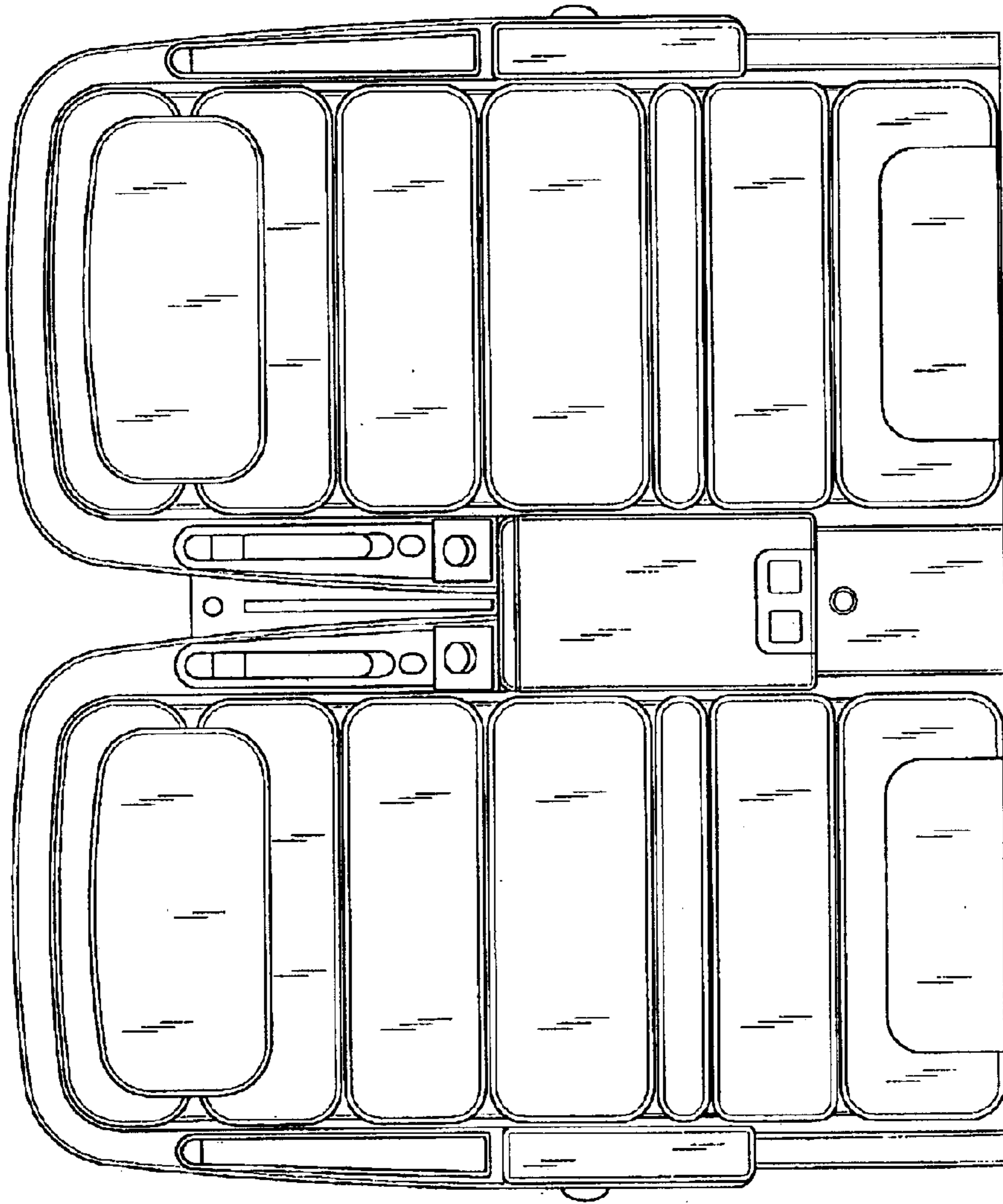

FIG. 3

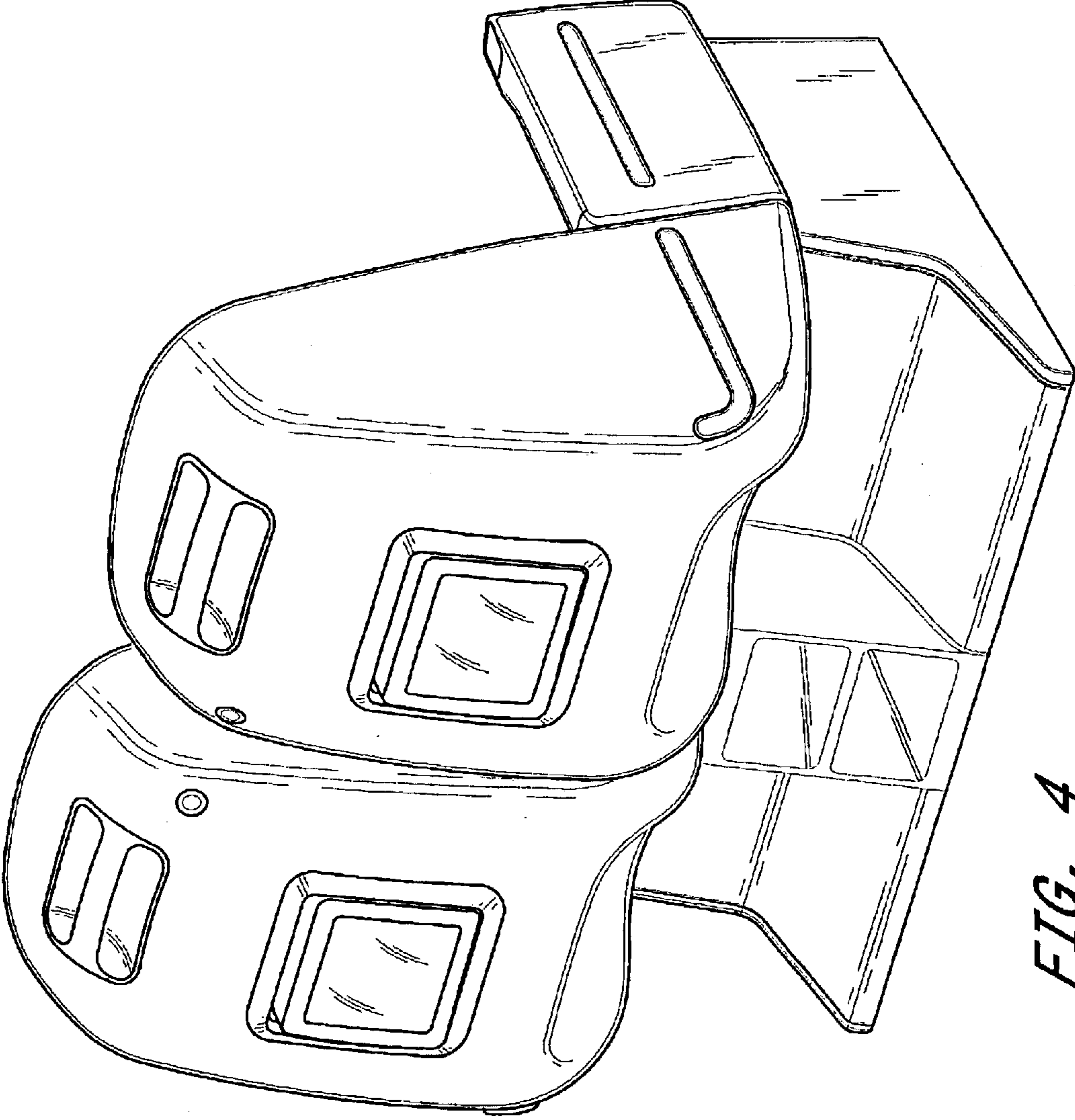

FIG. 4

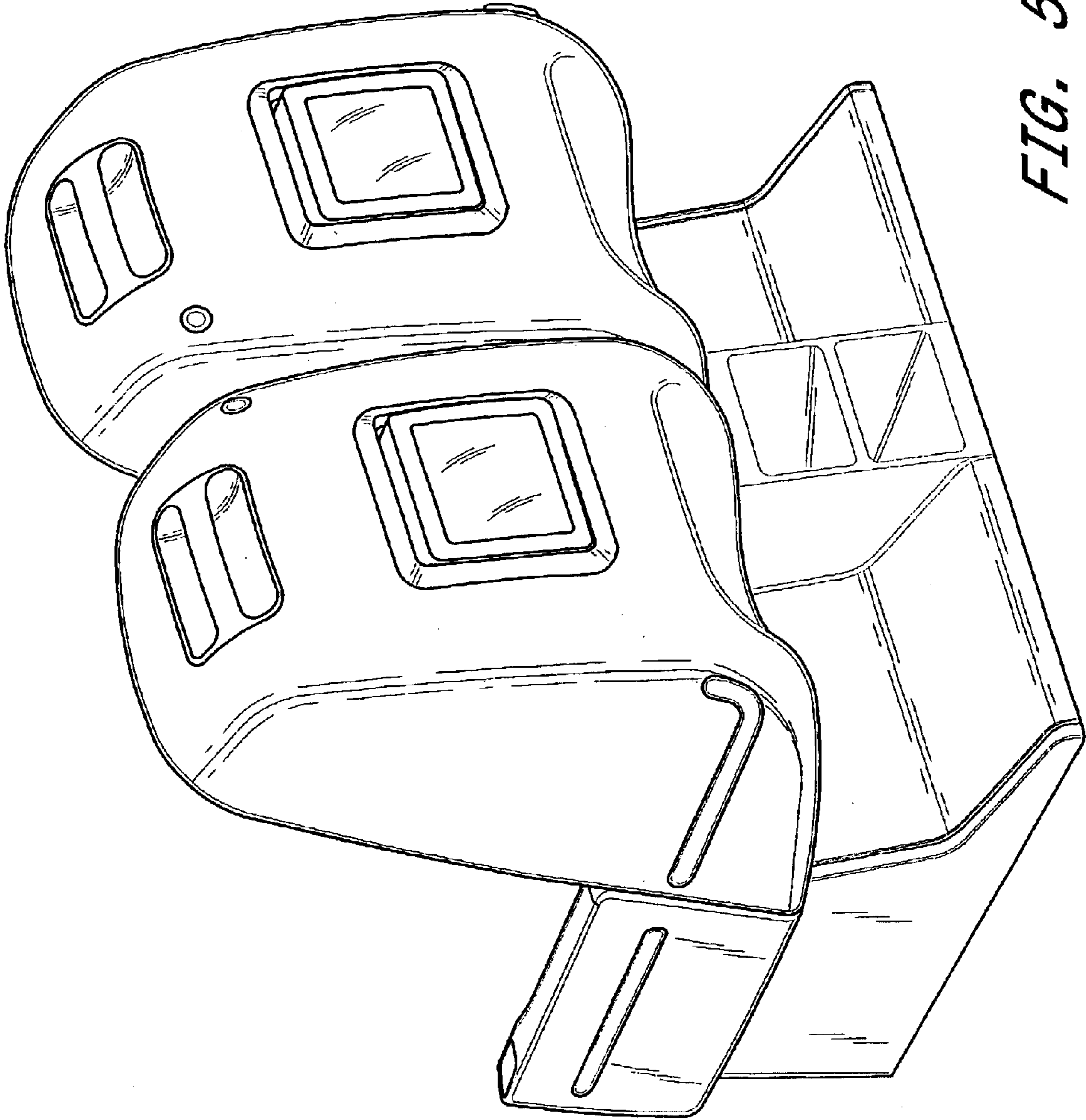

FIG. 5

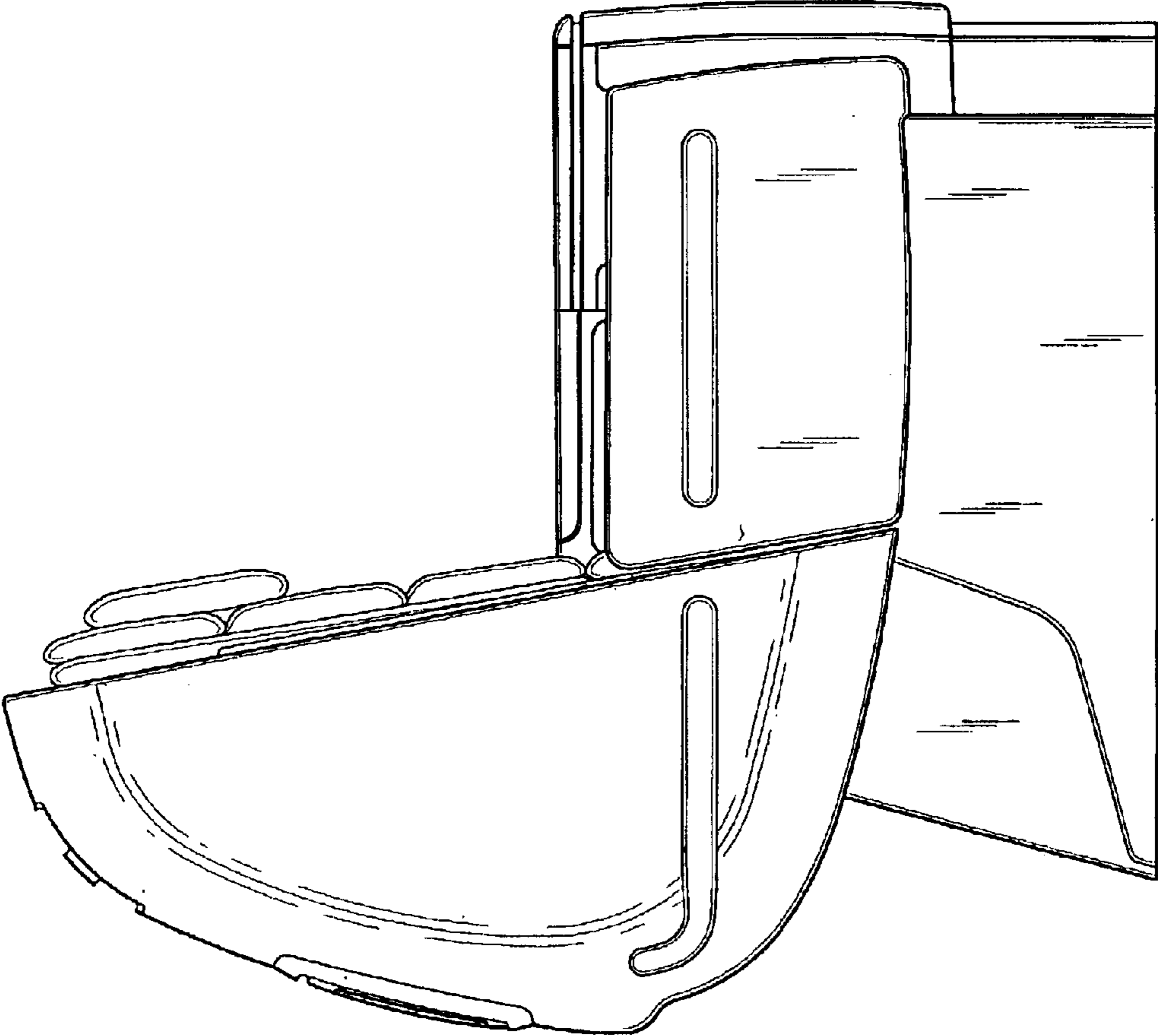

FIG. 6

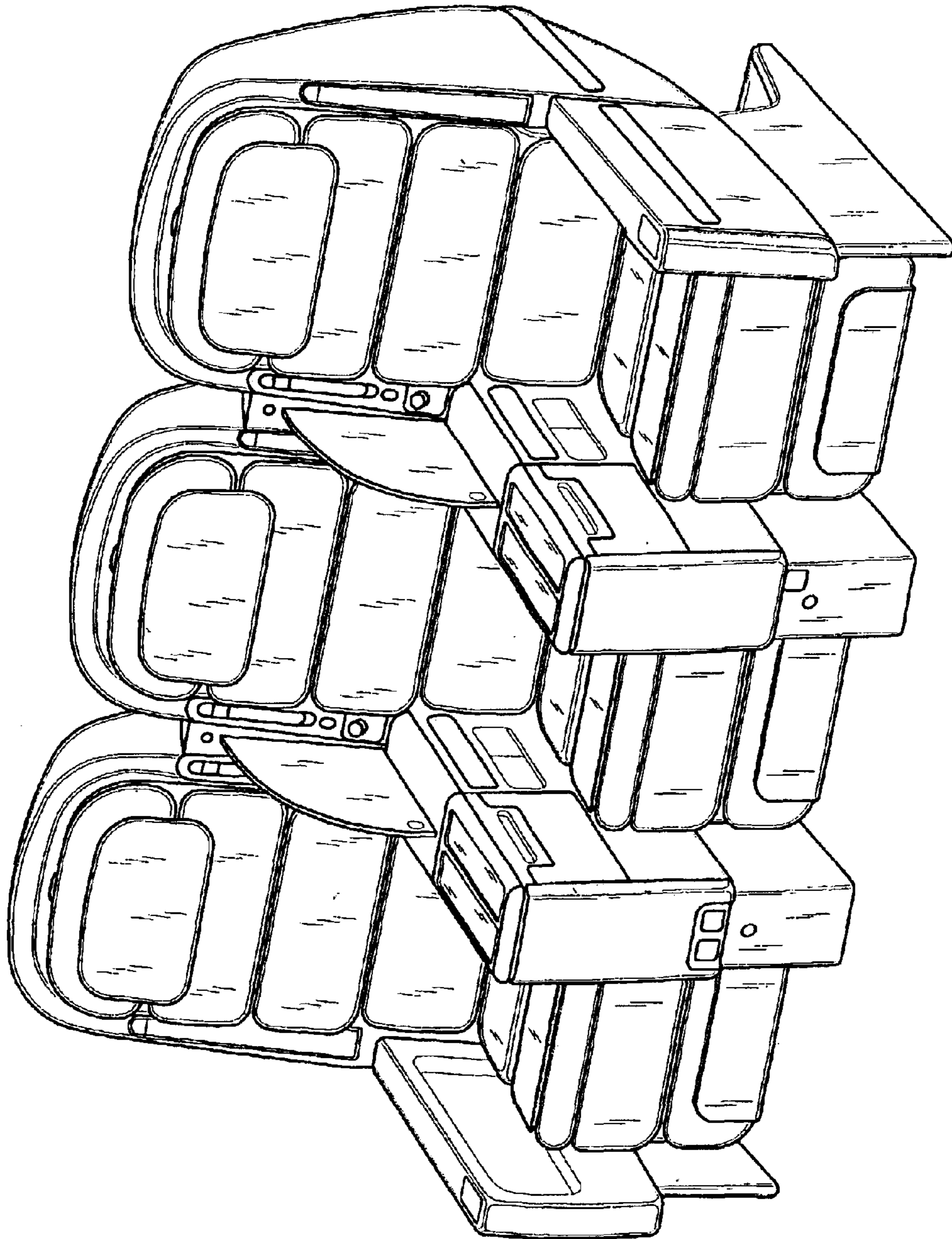

FIG. 7

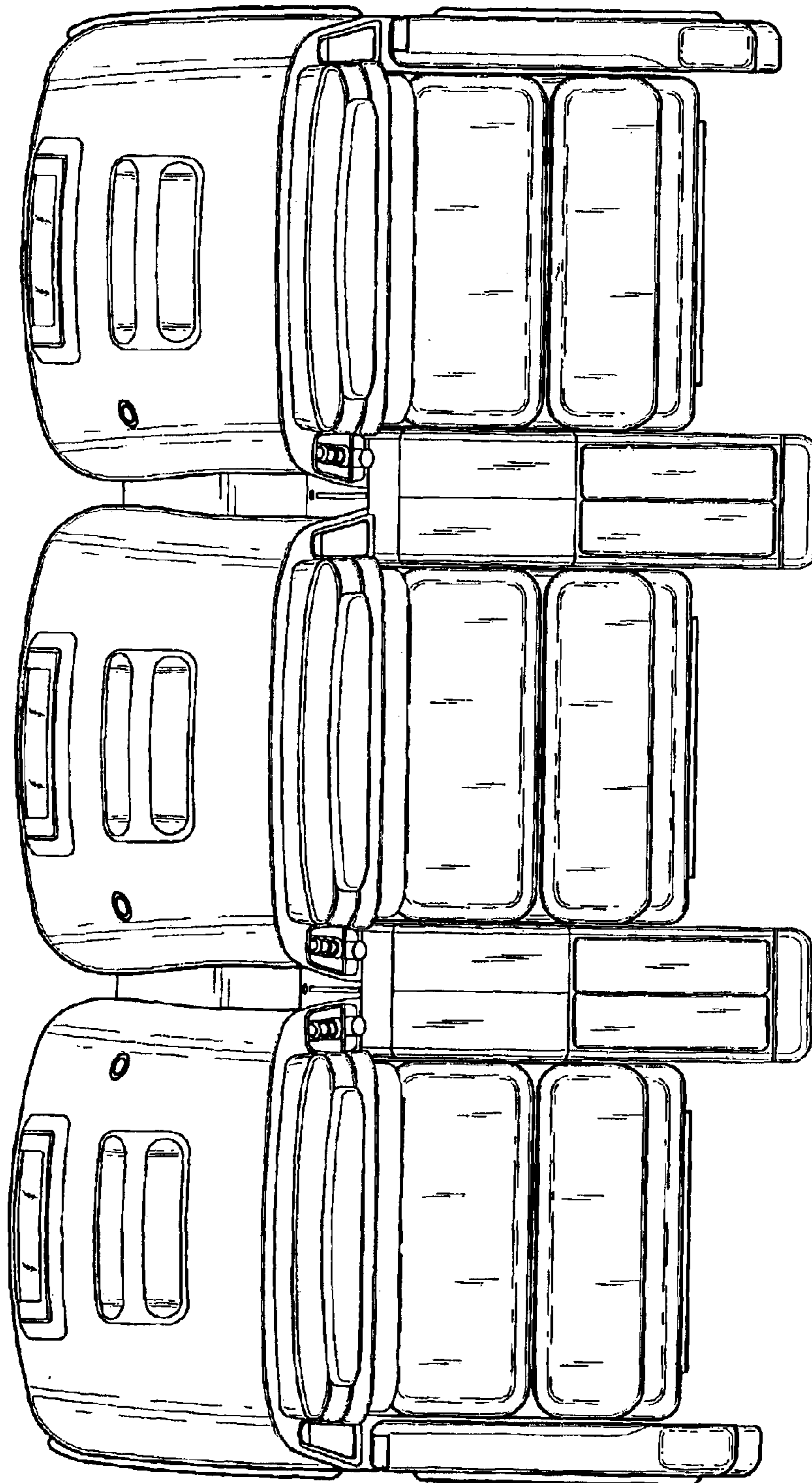

FIG. 8

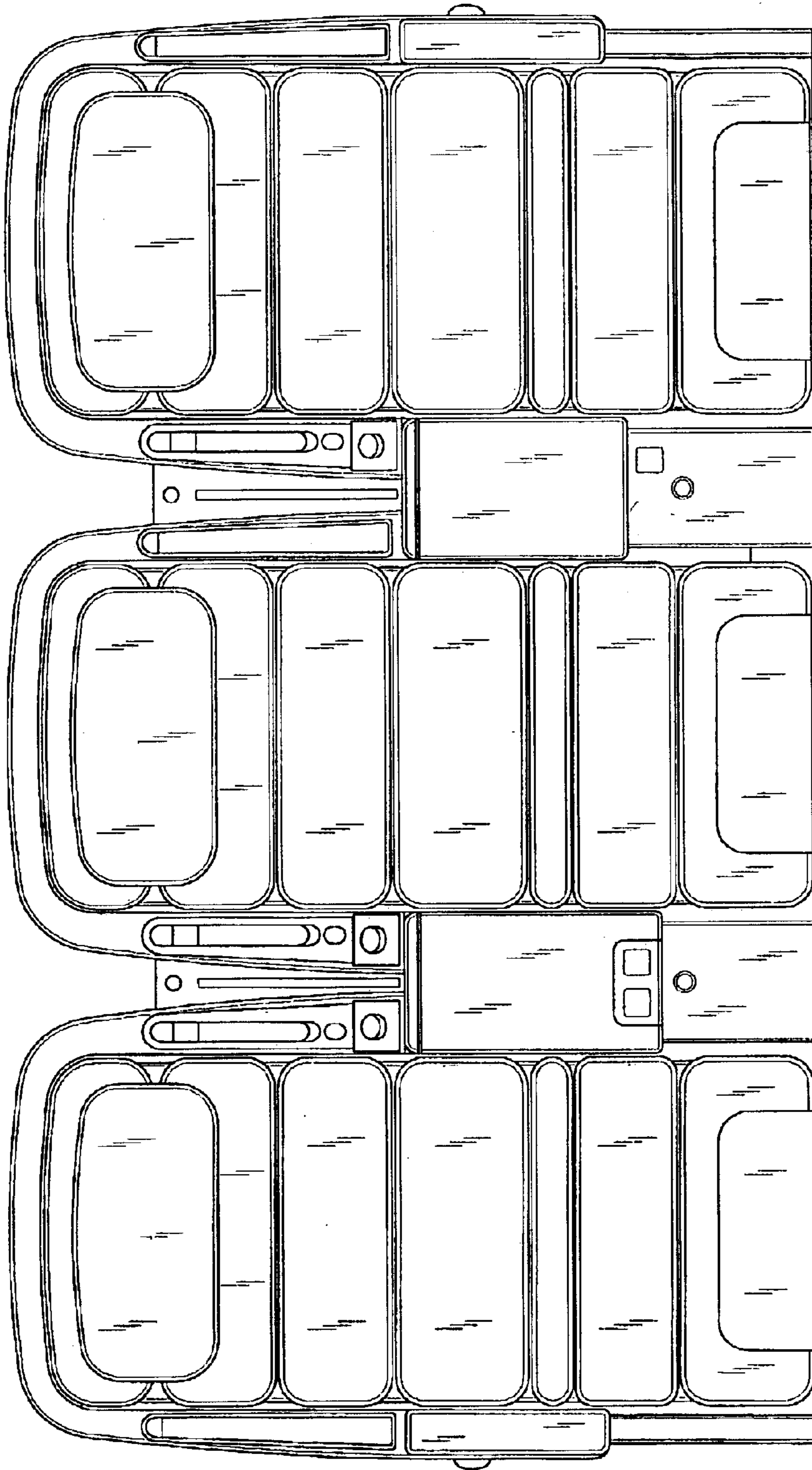

FIG. 9

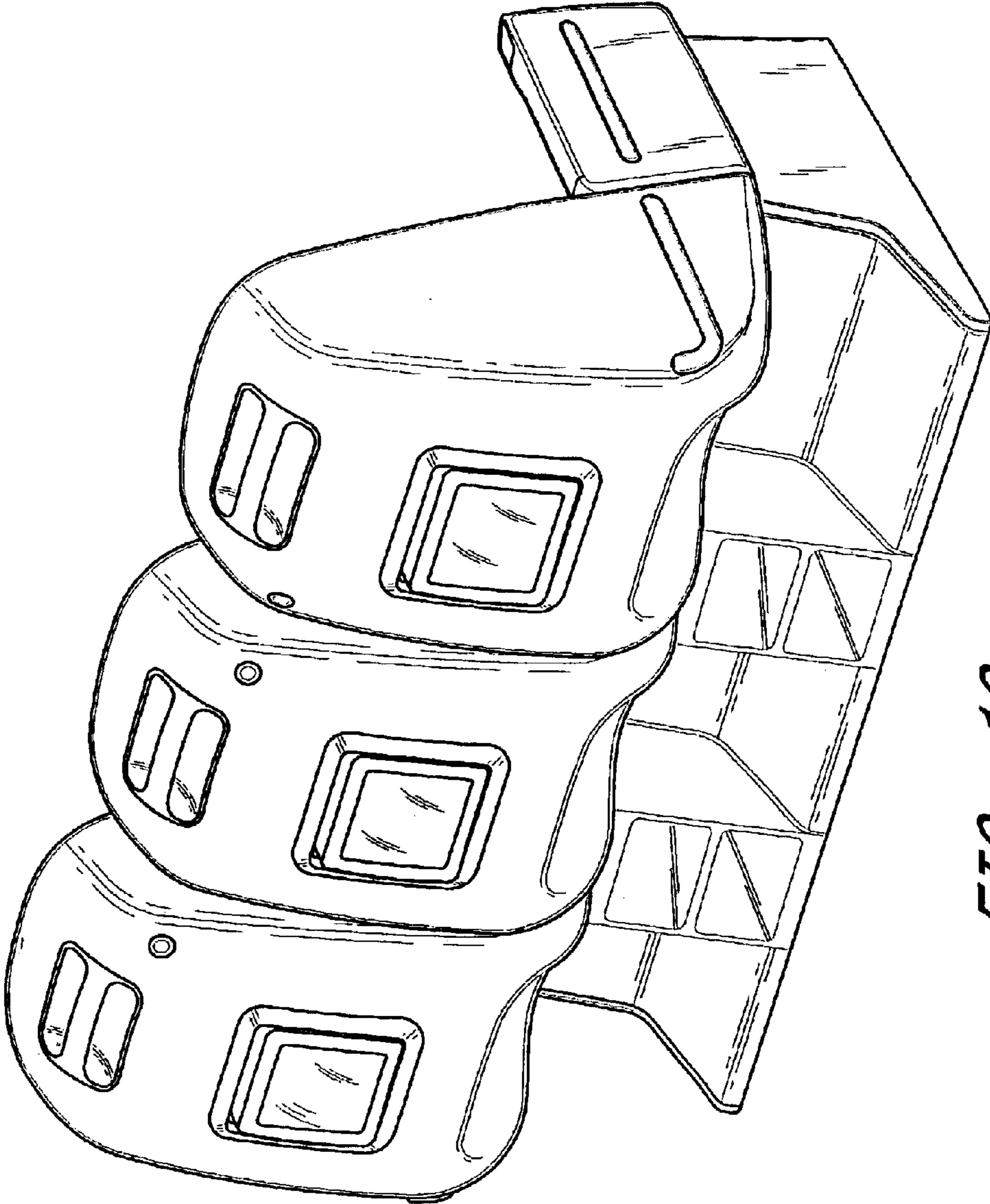

FIG. 10

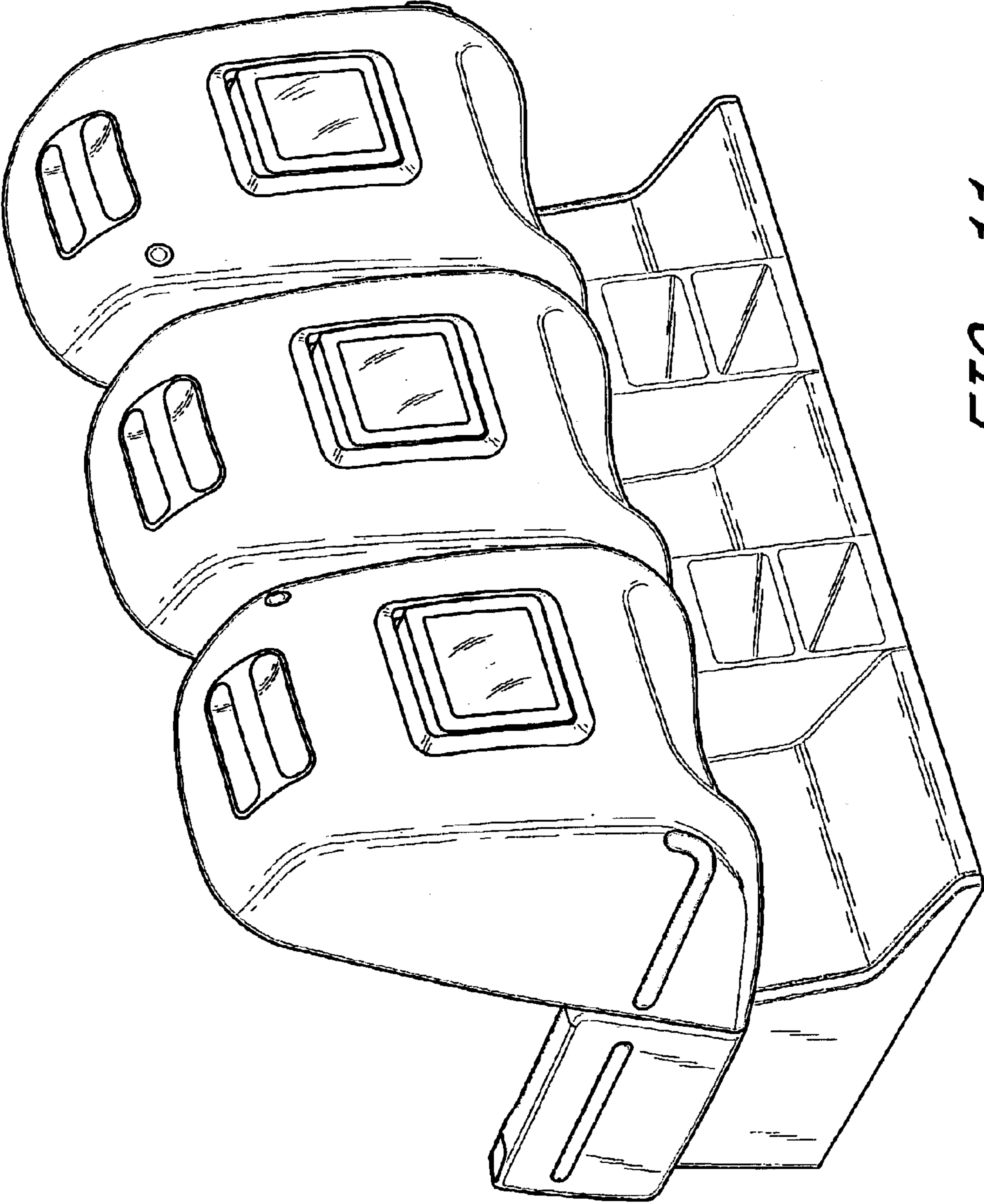

FIG. 11

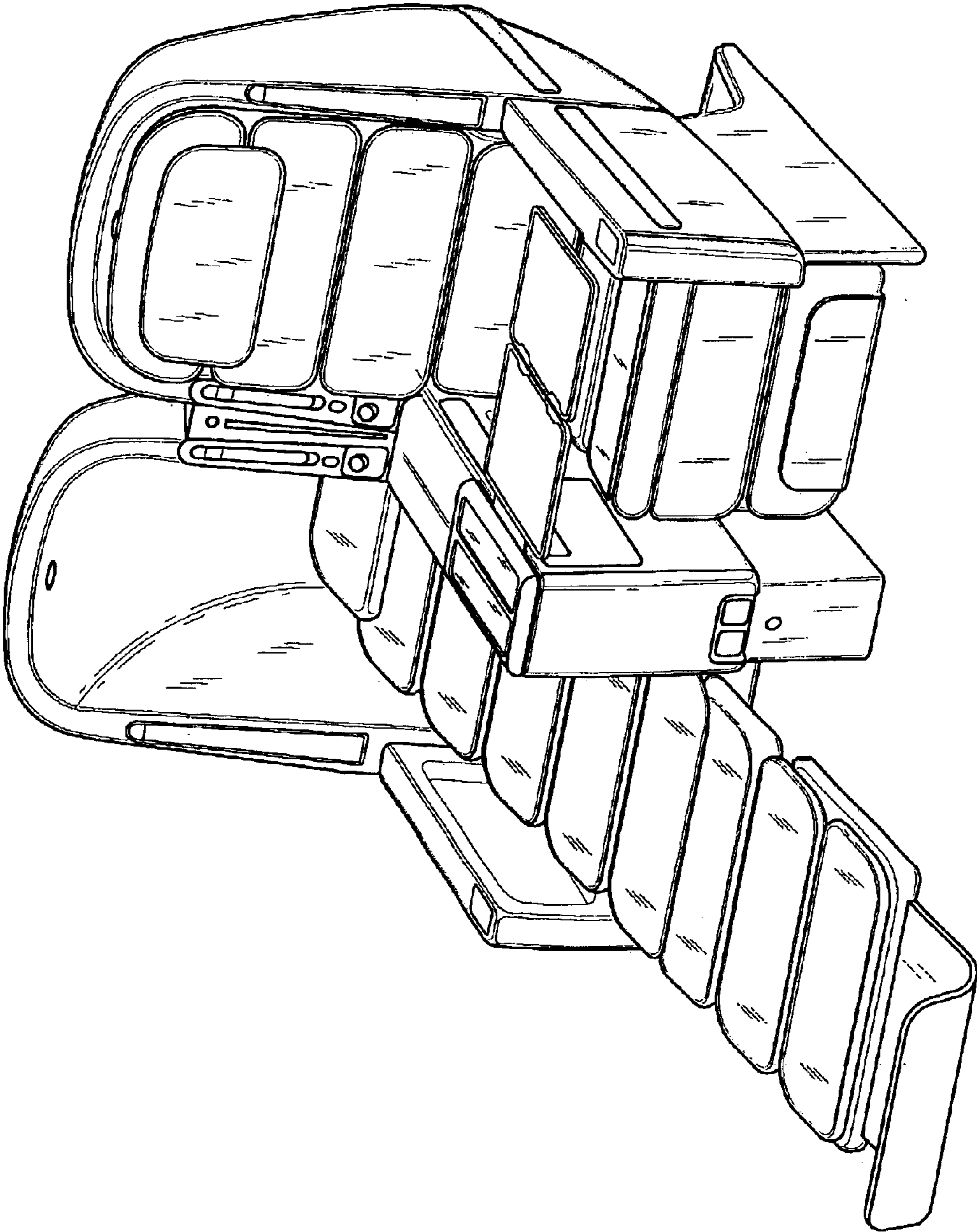

FIG. 12