

US00D492914S1

(12) **United States Design Patent** (10) **Patent No.:** **US D492,914 S**
VanPelt, II et al. (45) **Date of Patent:** **** Jul. 13, 2004**

(54) **SKIS THAT ATTACH TO A SCOOTER**

(75) Inventors: **Gene Arnold VanPelt, II**, Lynnwood, WA (US); **David Dennis Nelson**, Idaho Falls, ID (US)

(73) Assignee: **Ski Skoot, Inc.**, Sammamish, WA (US)

(**) Term: **14 Years**

(21) Appl. No.: **29/186,397**

(22) Filed: **Jul. 14, 2003**

(51) **LOC (7) Cl.** **12-14**

(52) **U.S. Cl.** **D12/8**

(58) **Field of Search** D12/6, 8, 9, 11;
D21/767; 280/7.12-7.14, 11.15, 14.27,
14.28

(56) **References Cited**

U.S. PATENT DOCUMENTS

1,968,975	A	*	8/1934	Upsacker et al.	280/14.28
D126,833	S	*	4/1941	Hylan	D12/8
2,316,272	A	*	4/1943	Meyer	280/14.28
D210,544	S	*	3/1968	Fleisher	D12/8
D460,137	S	*	7/2002	Burger	D21/767
D466,833	S	*	12/2002	Pan	D12/8
6,652,422	B1	*	11/2003	Day	280/14.28

* cited by examiner

Primary Examiner—Nelson C. Holtje

(74) *Attorney, Agent, or Firm*—Graybeal Jackson Haley LLP

(57) **CLAIM**

The ornamental design for skis that attach to a scooter, as shown and described.

DESCRIPTION

FIG. 1 is a perspective view of a front ski and a rear ski that respectively attach to a front and a rear portion of a scooter, with broken lines showing typical adjoining structures, including a scooter, for illustrative purposes only and forming no part of the claimed design;

FIG. 2 is a front view of the front ski;

FIG. 3 is a rear view of the front ski;

FIG. 4 is a right side view of the front ski;

FIG. 5 is left side view of the front ski;

FIG. 6 is top plan view of the front ski;

FIG. 7 is a bottom plan view of the front ski;

FIG. 8 is a front view of the rear ski;

FIG. 9 is rear view of the rear ski;

FIG. 10 is left side view of the rear ski;

FIG. 11 is a right side view of the rear ski;

FIG. 12 is top plan view of the rear ski, with a broken line showing adjoining structure for illustrative purposes only and forming no part of the claimed design; and,

FIG. 13 is a bottom plan view of the rear ski.

1 Claim, 5 Drawing Sheets

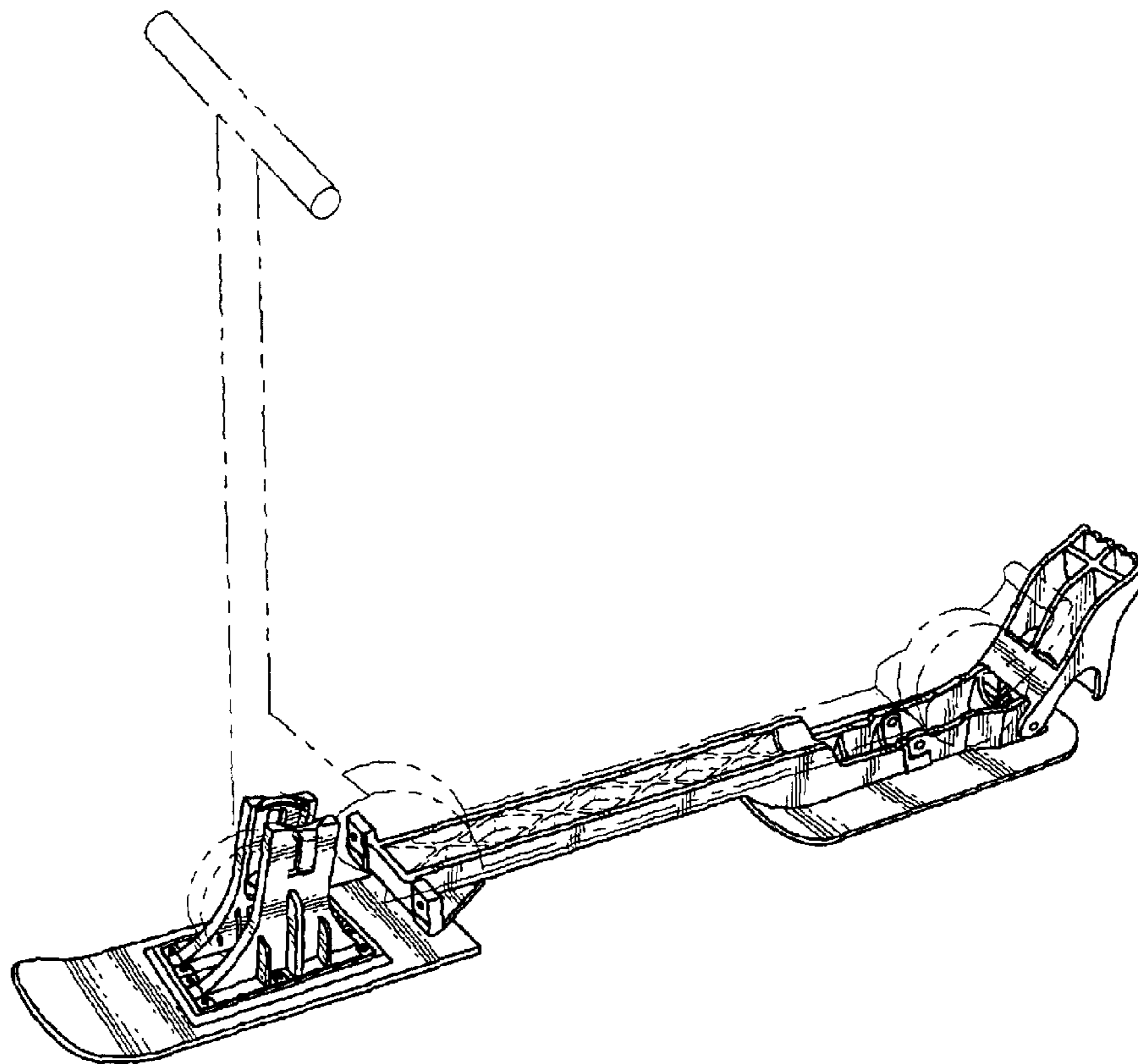

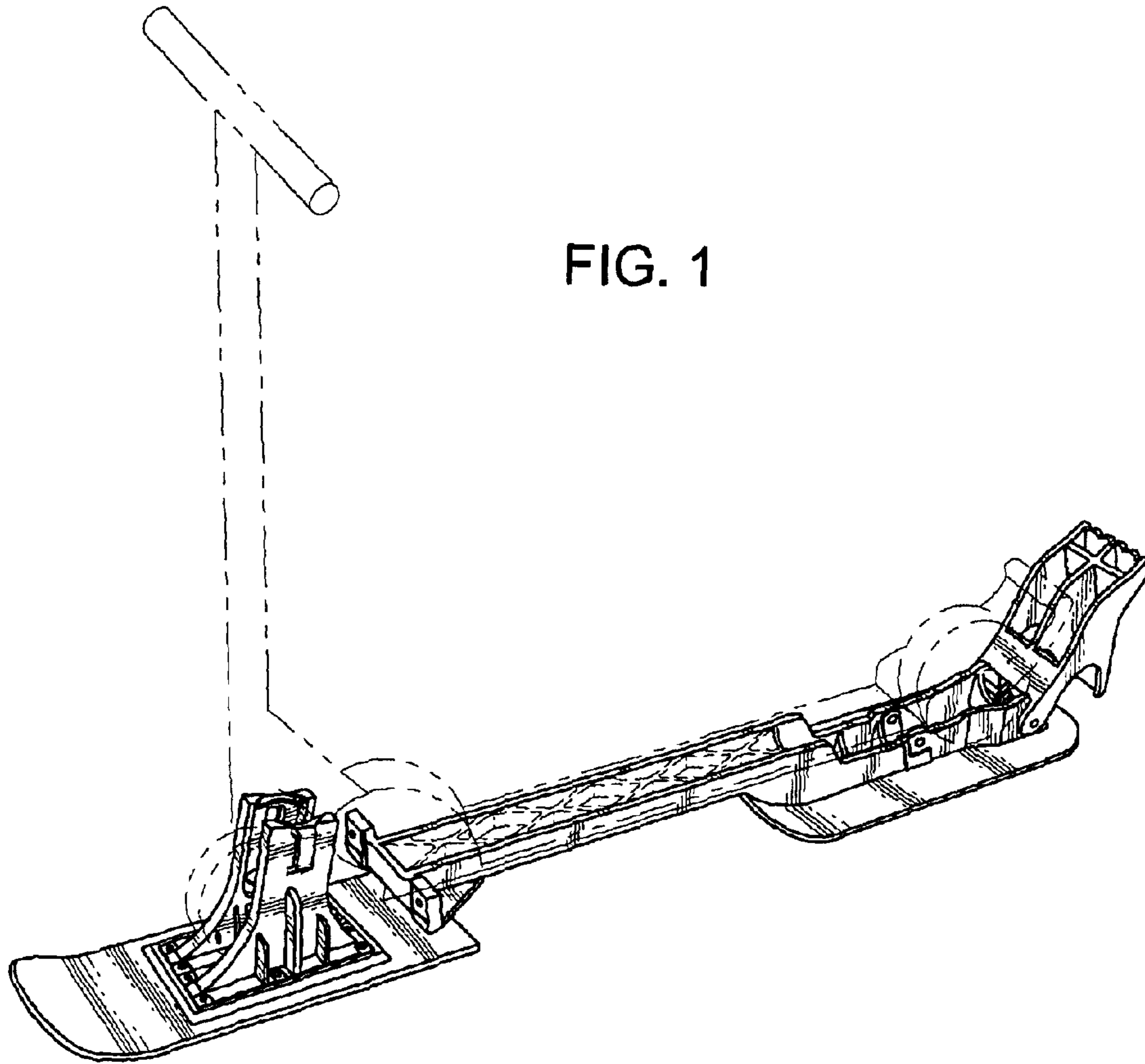

FIG. 1

FIG. 2

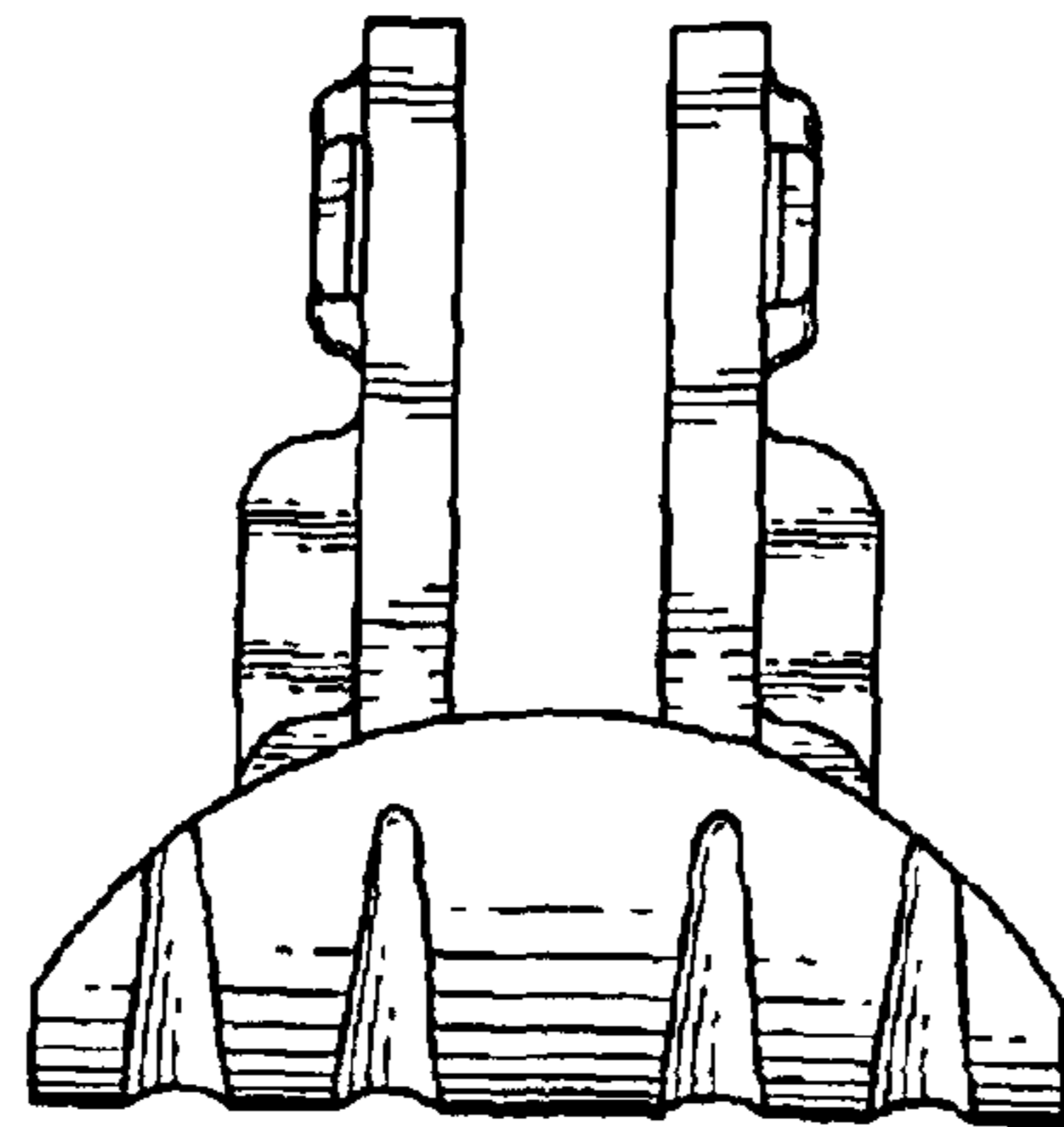
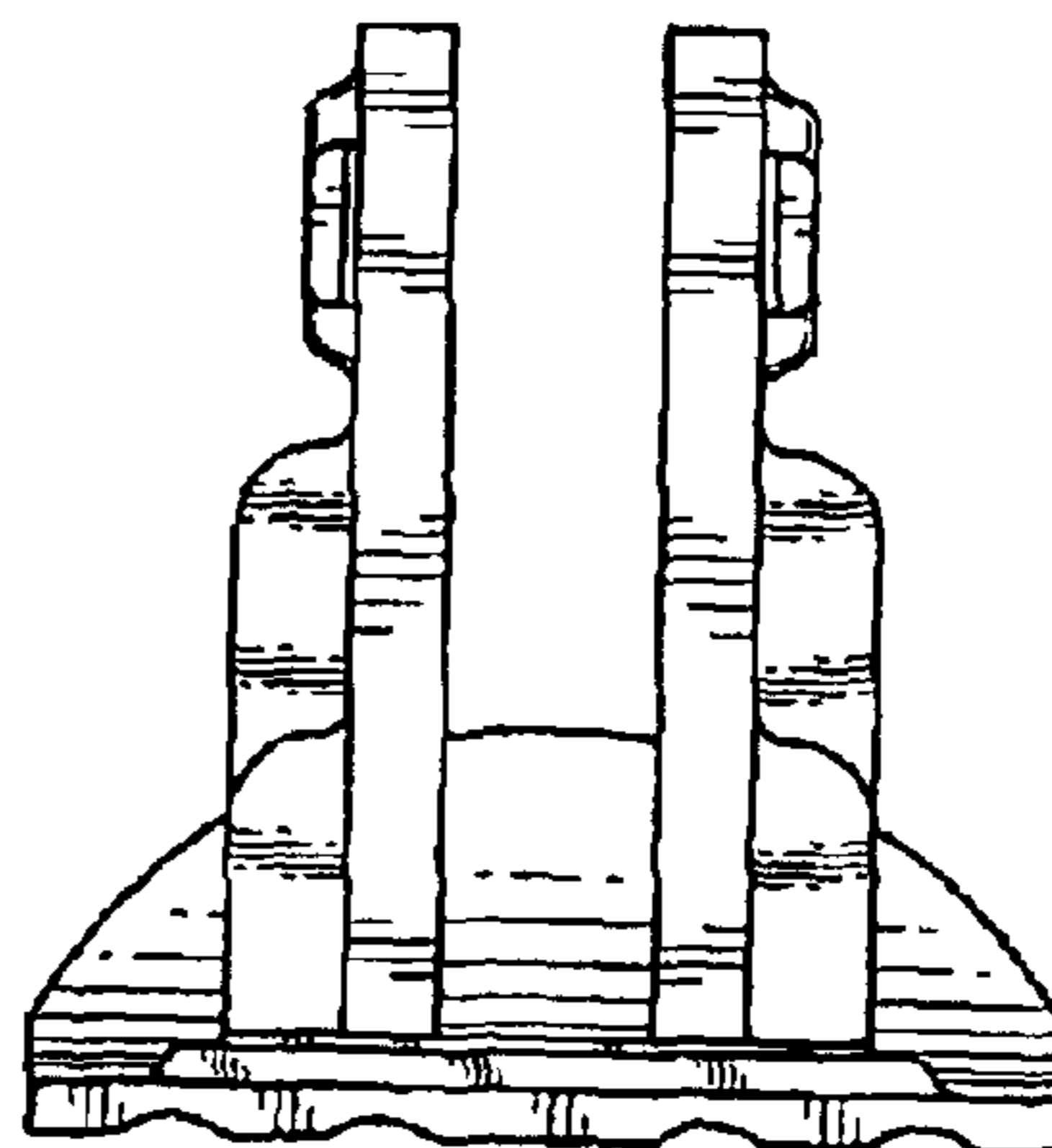

FIG. 3



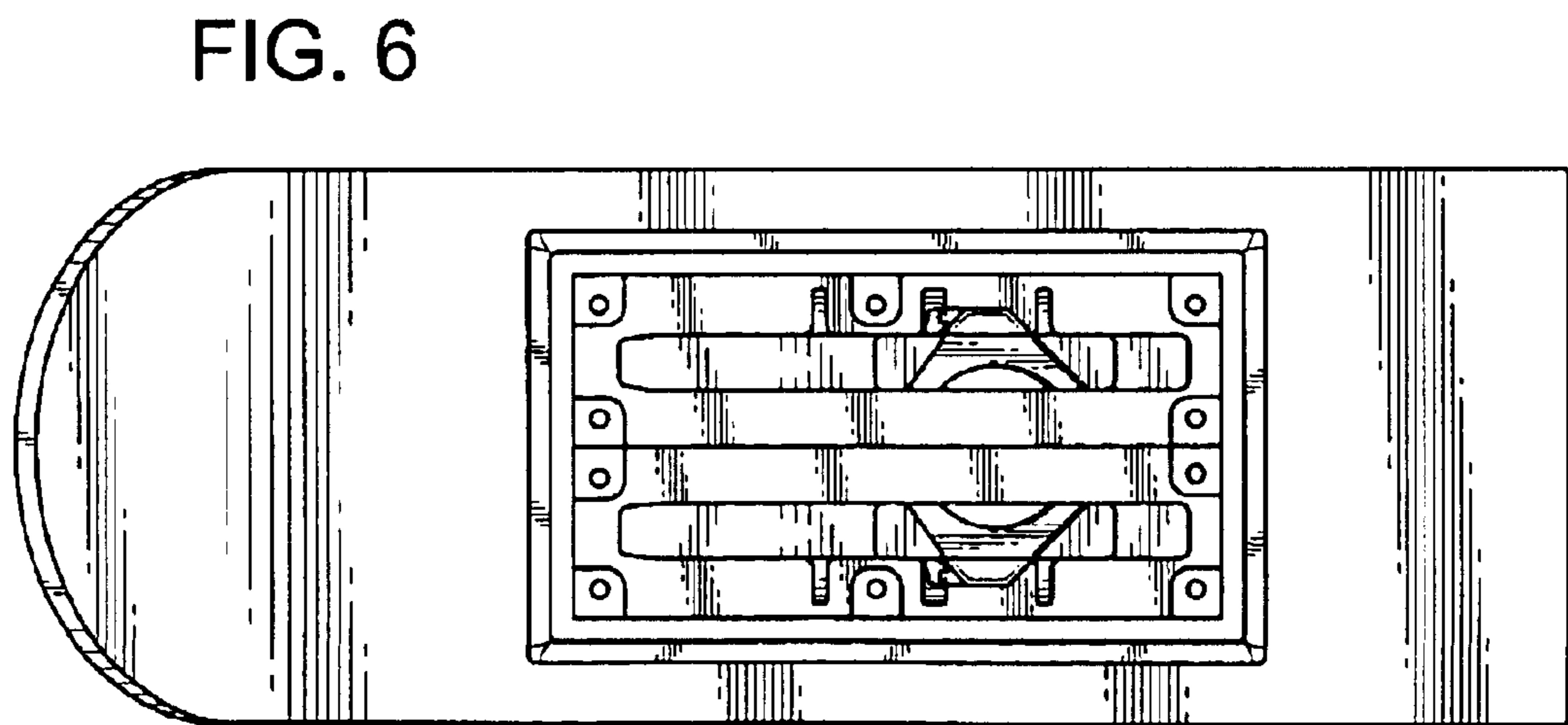
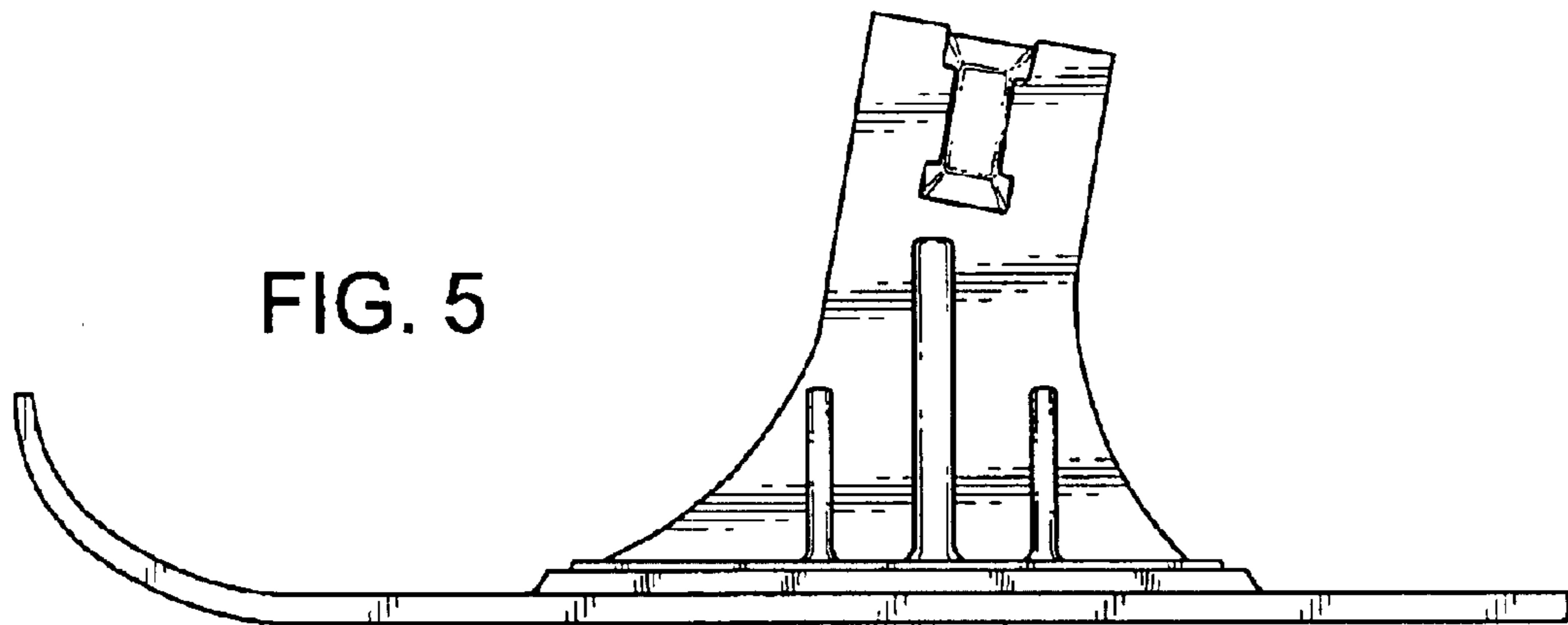
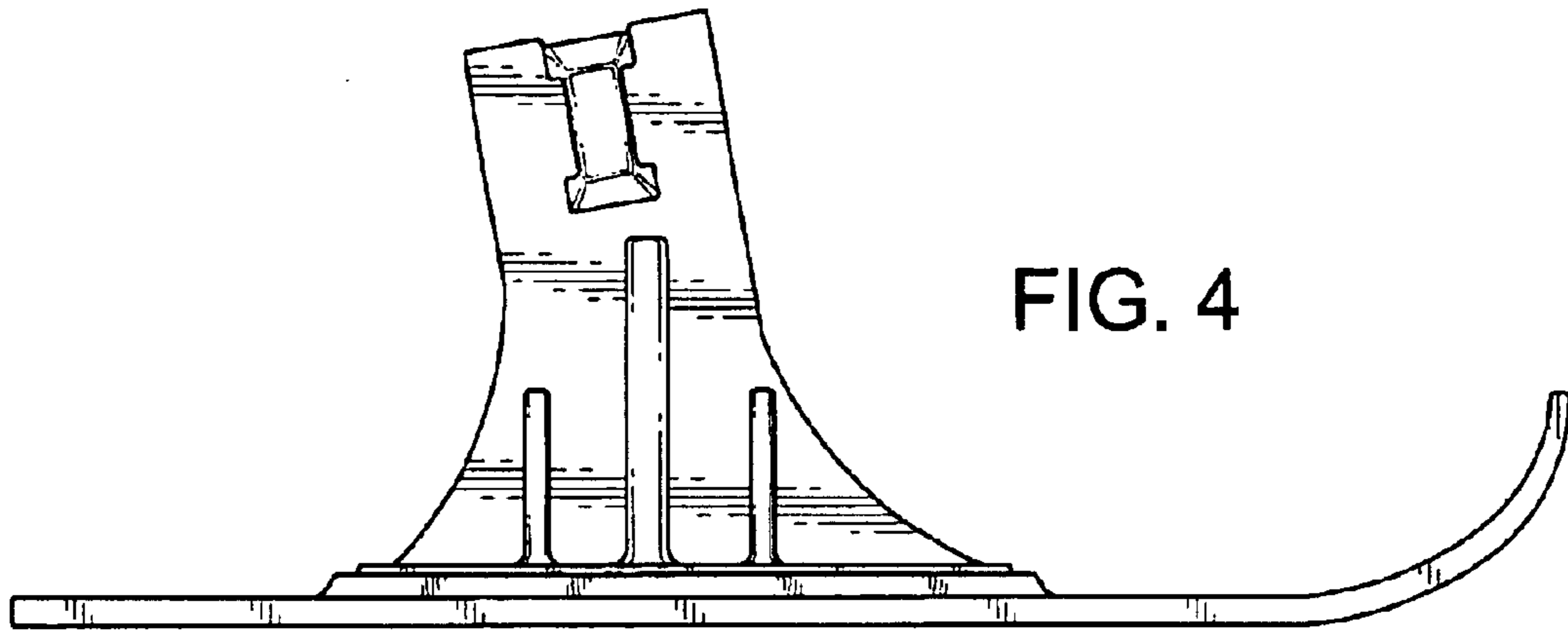

FIG. 7

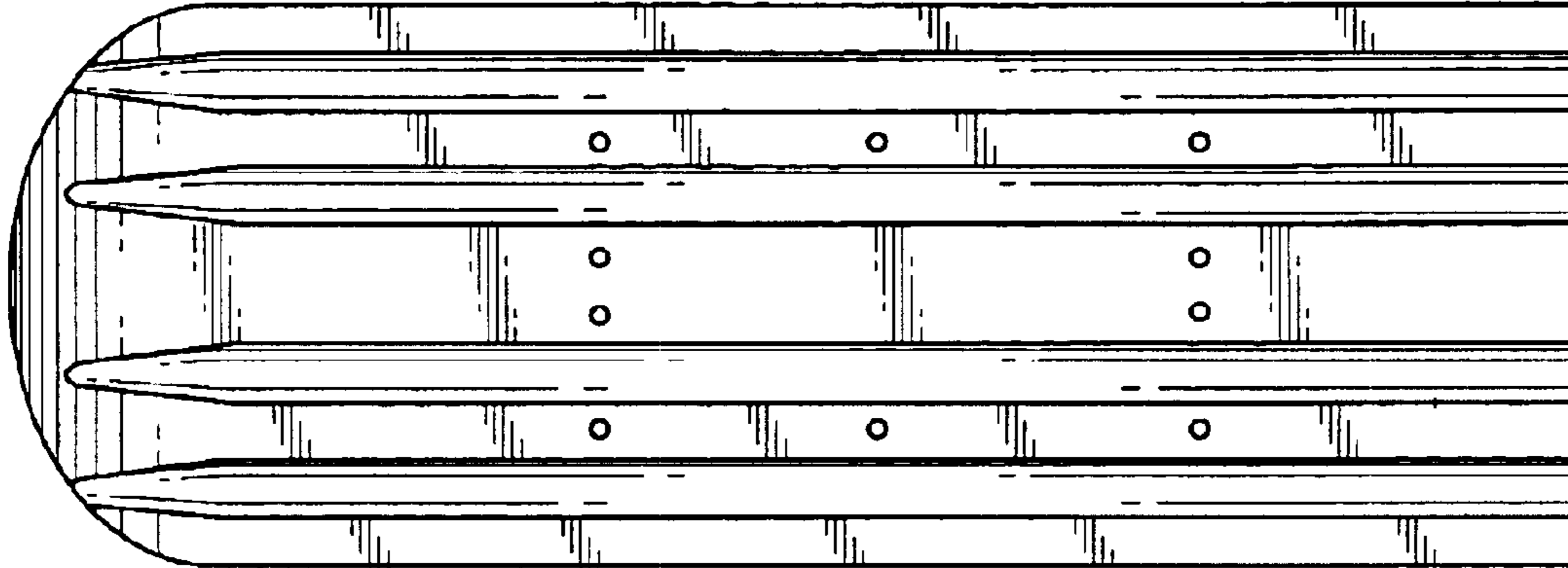

FIG. 8

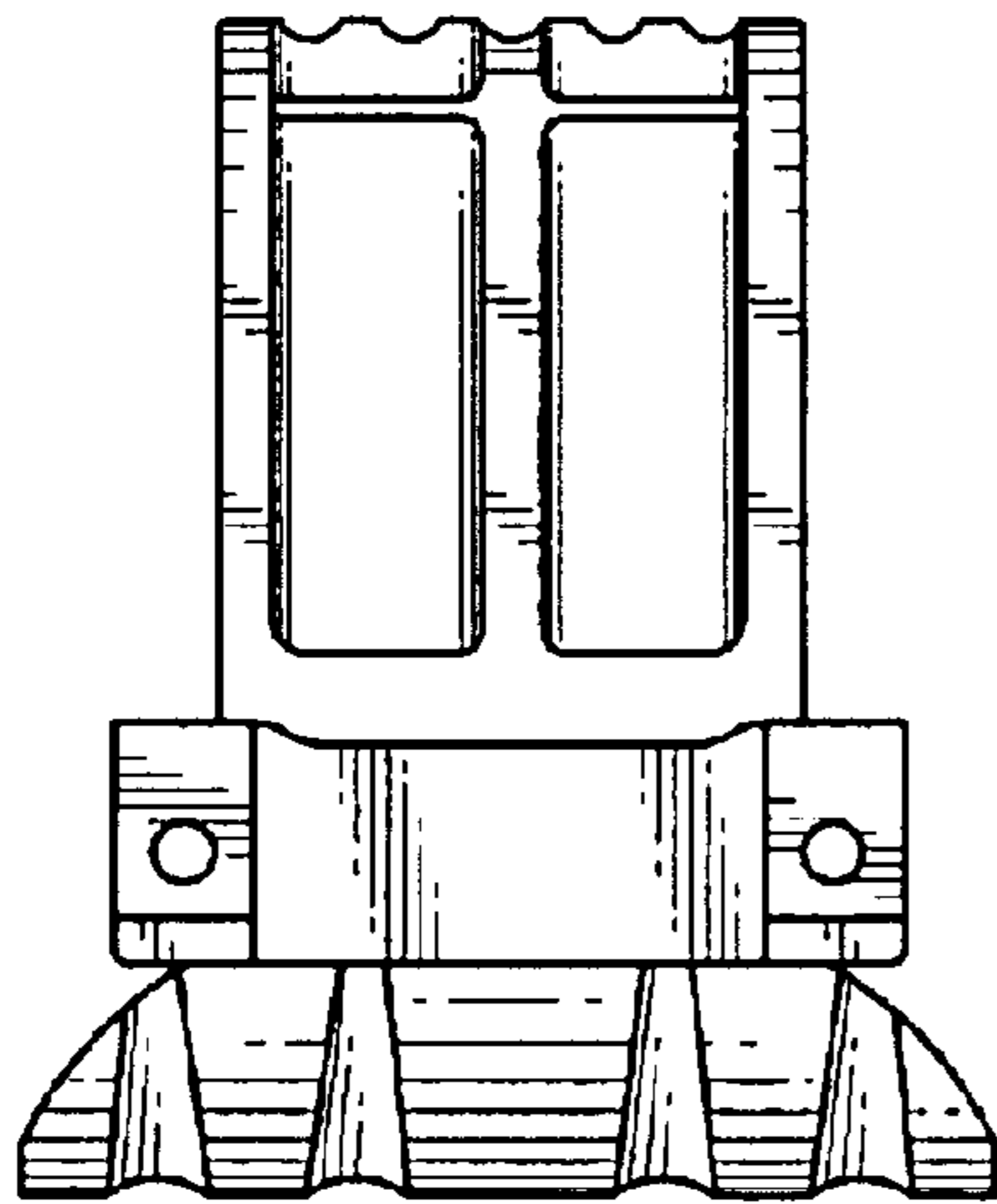
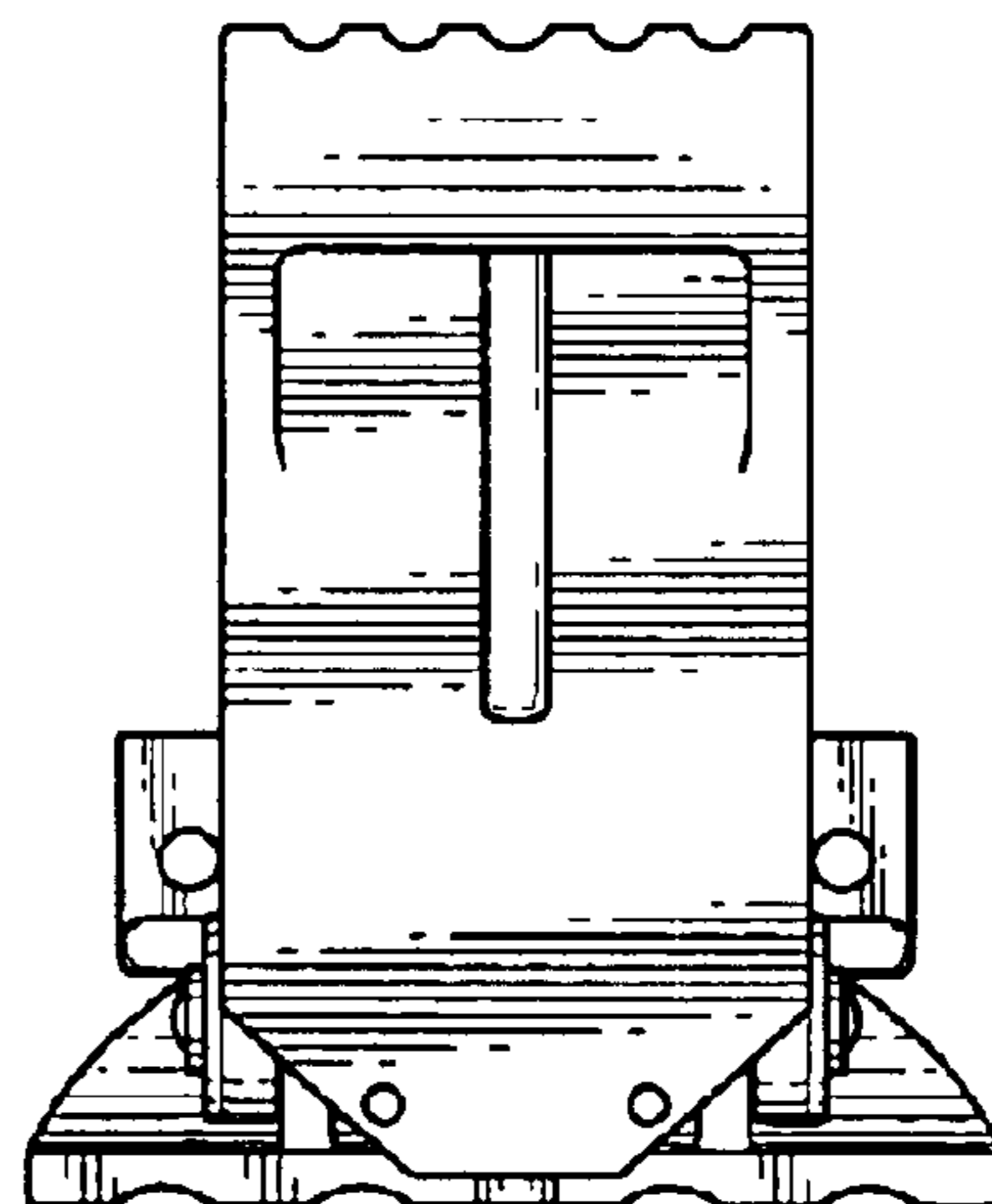

FIG. 9



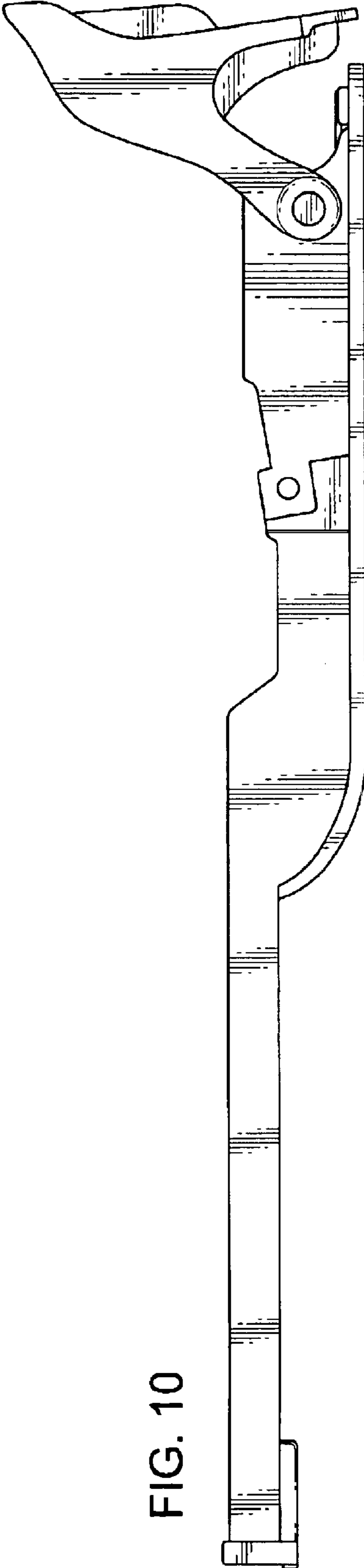

FIG. 10

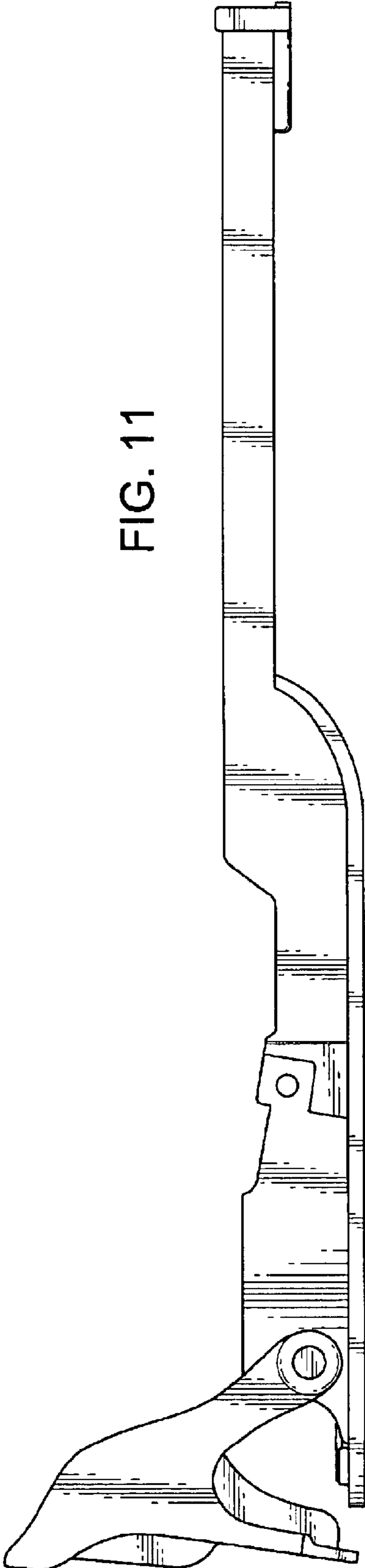

FIG. 11

