

US00D492738S1

(12) **United States Design Patent**
Darack

(10) **Patent No.:** **US D492,738 S**

(45) **Date of Patent:** **** Jul. 6, 2004**

(54) **AIRCRAFT**

(76) **Inventor:** **Ed Darack**, P.O. Box 413, Fort
Garland, CO (US) 81133

(**) **Term:** **14 Years**

(21) **Appl. No.:** **29/195,181**

(22) **Filed:** **Dec. 6, 2003**

(51) **LOC (7) Cl.** **21-01**

(52) **U.S. Cl.** **D21/449; D12/321**

(58) **Field of Search** D21/436, 445,
D21/447, 449, 453, 454; D12/319-345;
446/34, 61-68, 88, 108, 109, 429, 430,
487, 488

(56) **References Cited**

U.S. PATENT DOCUMENTS

D57,647 S	4/1921	Harris	
1,792,779 A	* 2/1931	Tarr	446/66
2,140,821 A	* 12/1938	Tyrrell	446/66
2,669,403 A	* 2/1954	McKay	244/155 R
2,739,414 A	* 3/1956	Cleveland	446/66
D278,729 S	* 5/1985	Ninomiya	D21/449
D278,730 S	* 5/1985	Ninomiya	D21/449
D278,837 S	5/1985	Ninomiya	

D311,223 S	* 10/1990	Kovats	D21/445
D314,987 S	* 2/1991	Kovats	D21/445
D316,578 S	* 4/1991	Kovats	D21/445
D370,502 S	6/1996	Nye	
D377,333 S	1/1997	Liu	
D453,947 S	2/2002	Paivanas	

* cited by examiner

Primary Examiner—Philip S. Hyder

Assistant Examiner—C. Tuttle

(57) **CLAIM**

The ornamental design for an aircraft, substantially as shown and described.

DESCRIPTION

FIG. 1 is a perspective view of an aircraft showing my new design;

FIG. 2 is a left side elevation view of the aircraft of FIG. 1, the right side elevation view being a mirror image of that shown;

FIG. 3 is a top plan view of the aircraft of FIG. 1;

FIG. 4 is a bottom plan view of the aircraft of FIG. 1;

FIG. 5 is a front elevation view of the aircraft of FIG. 1; and,

FIG. 6 is a rear elevation view of the aircraft of FIG. 1.

1 Claim, 3 Drawing Sheets

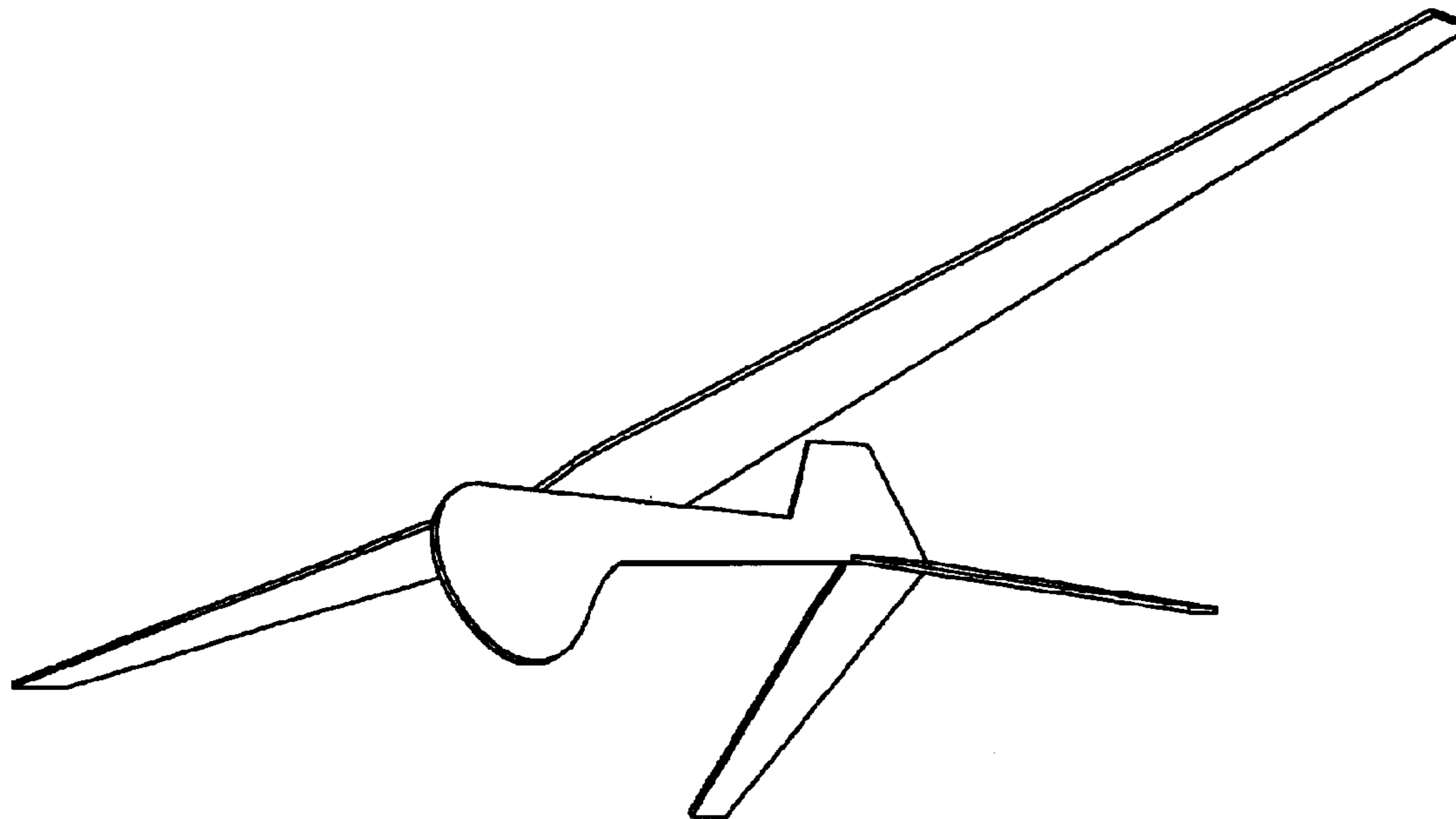

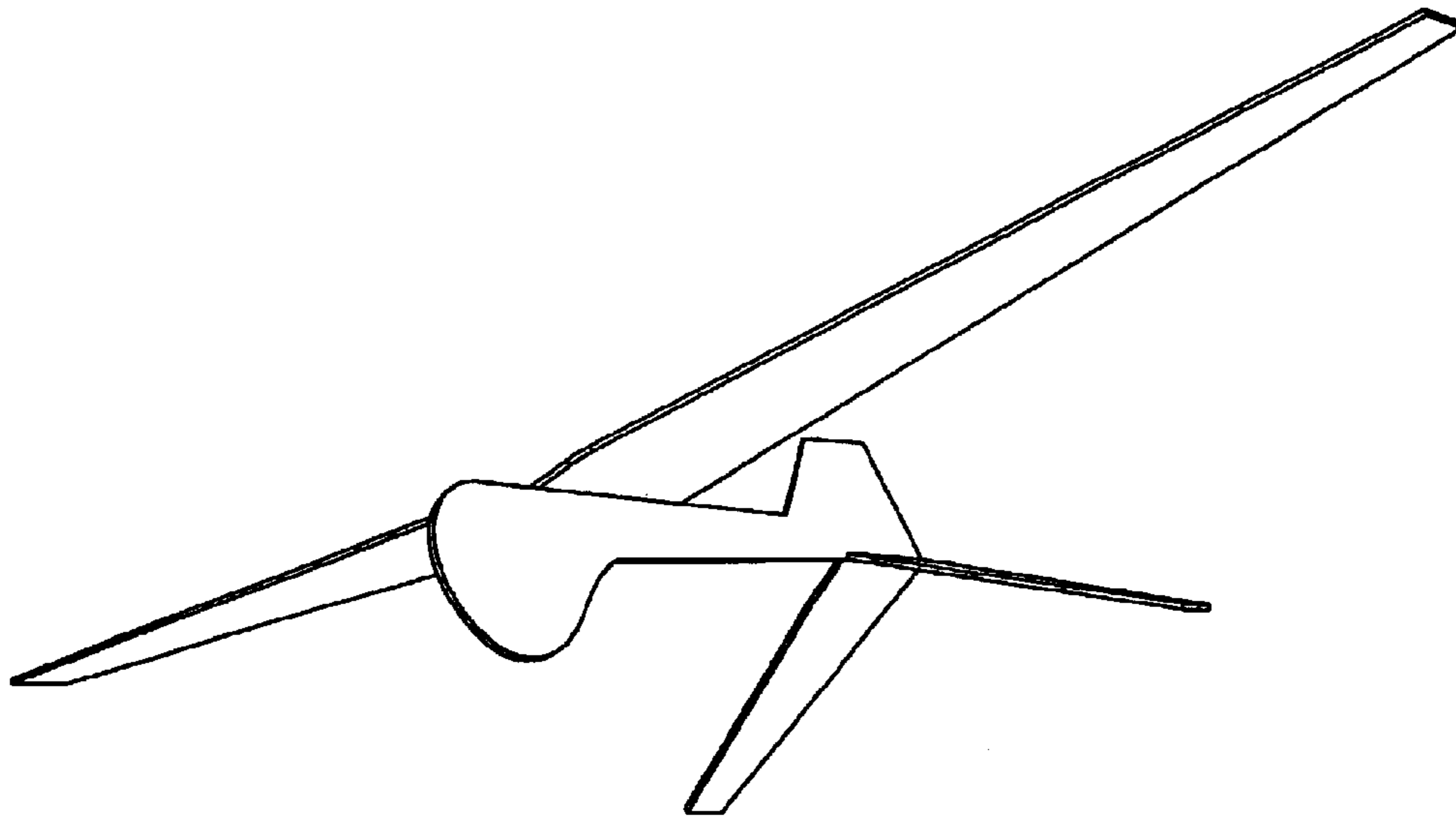

FIG. 1

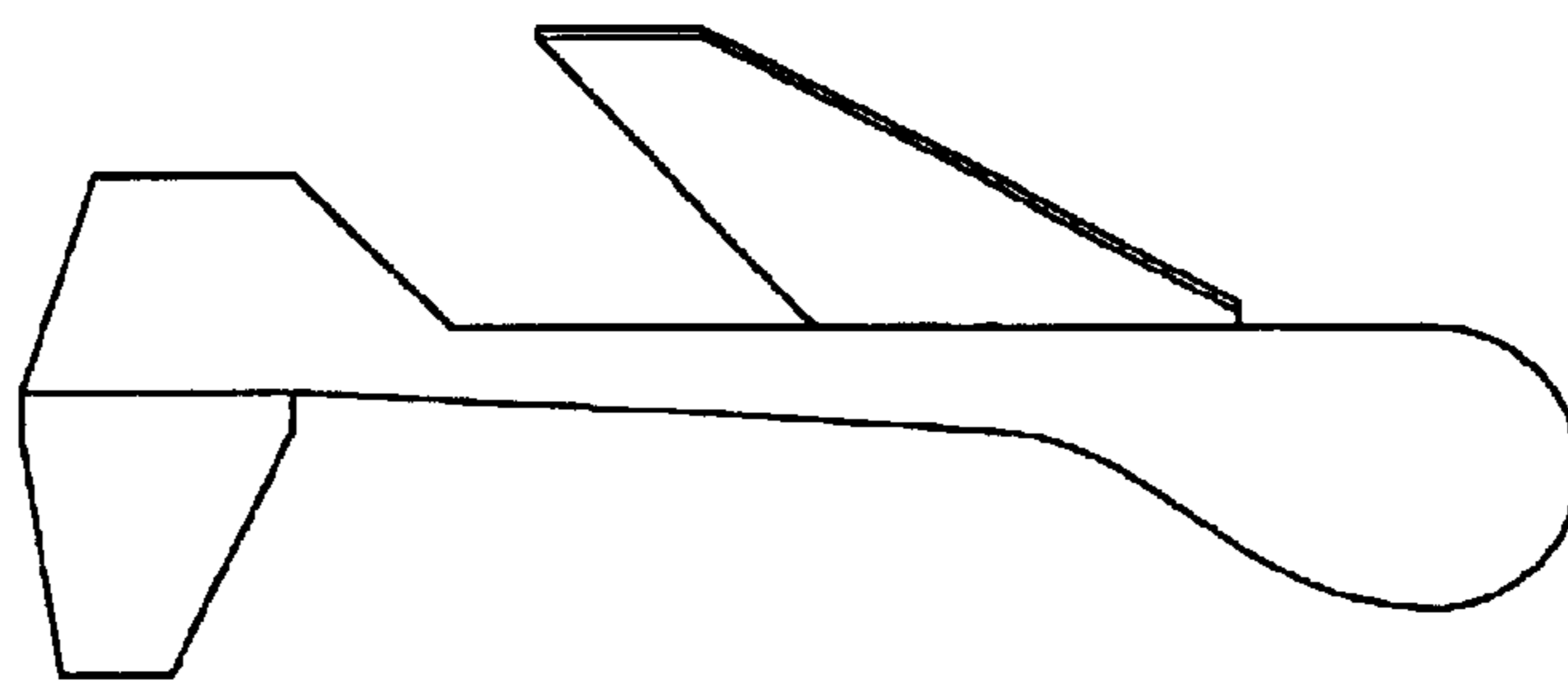

FIG. 2

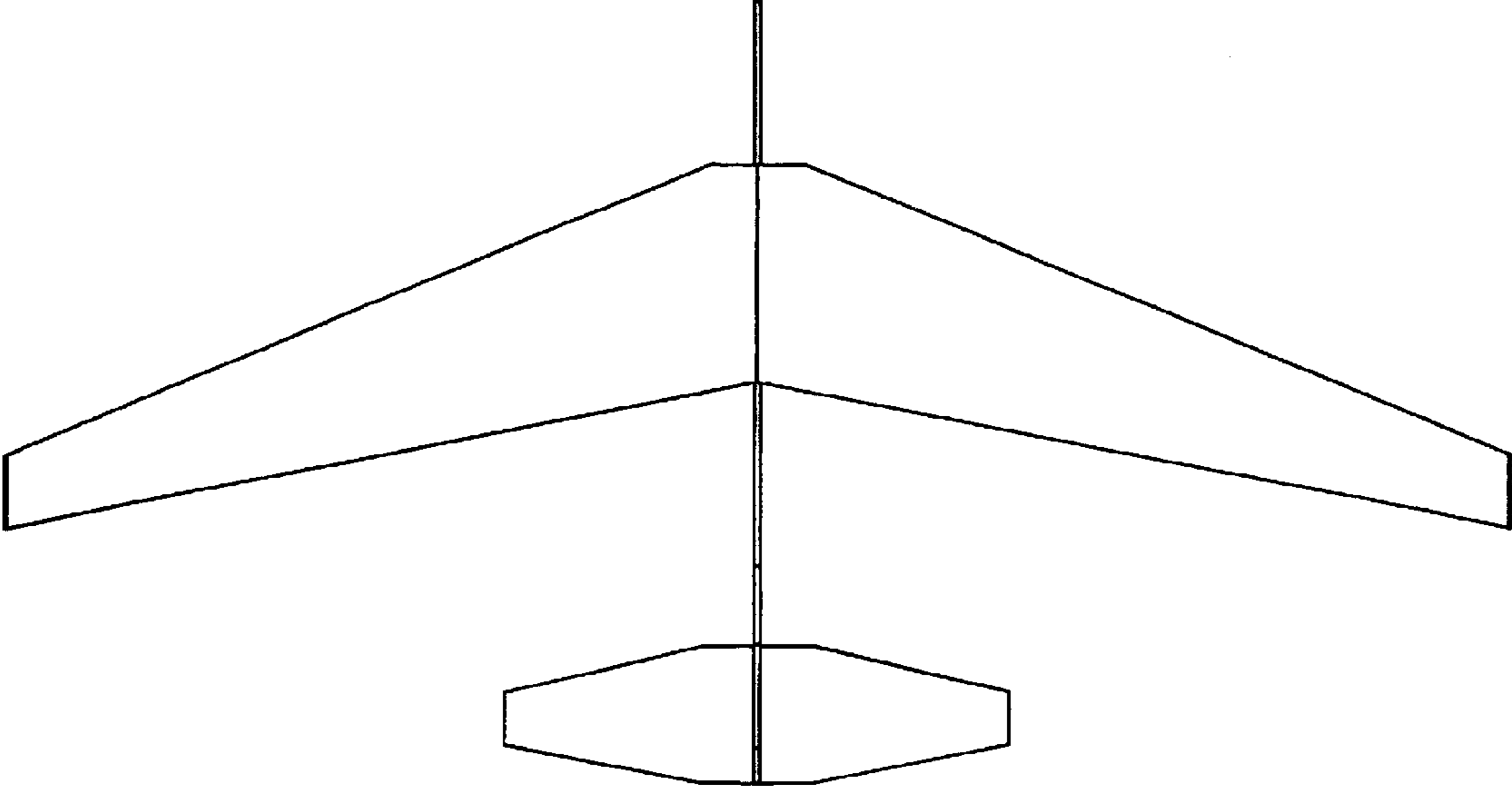

FIG. 3

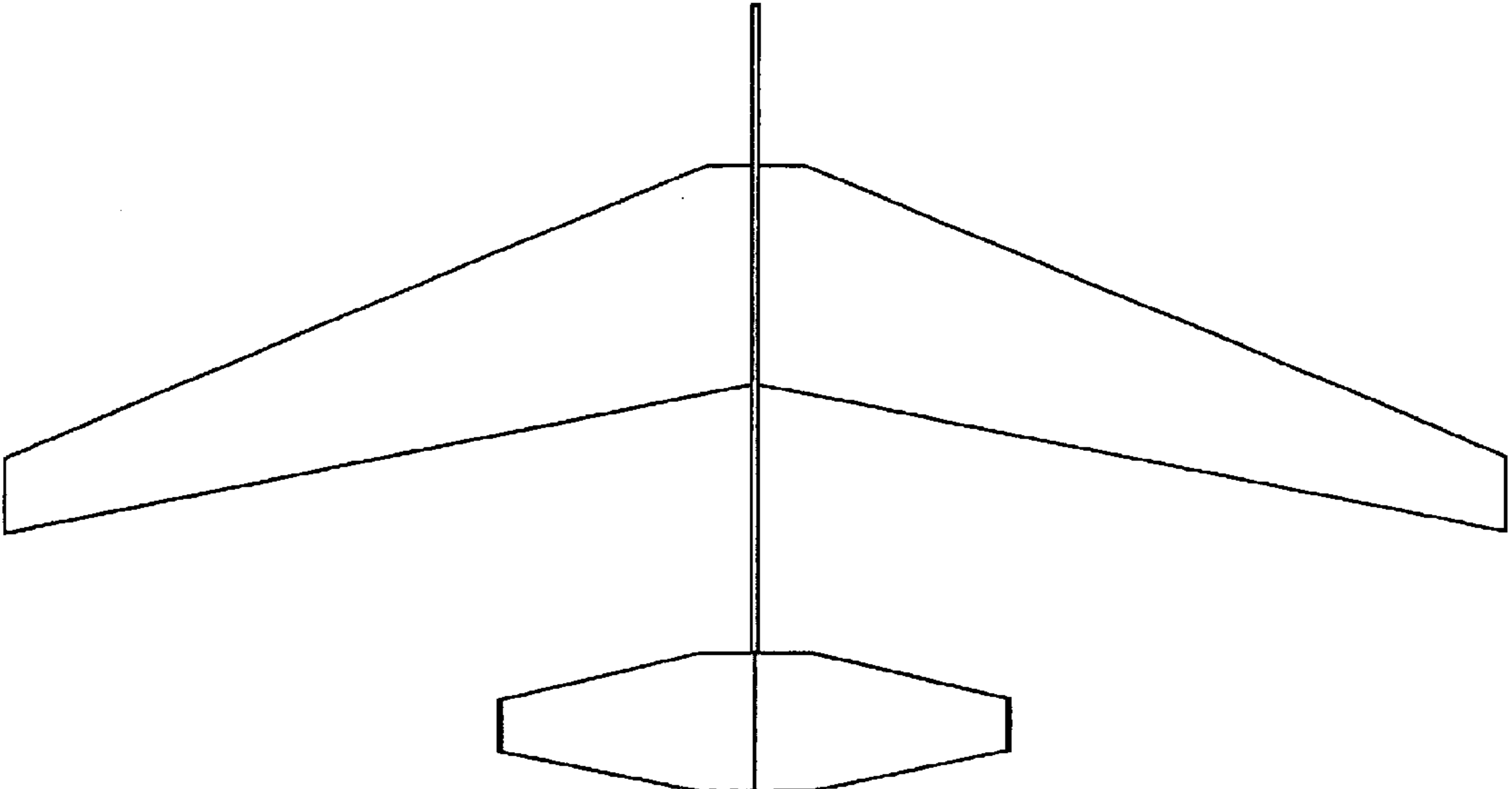

FIG. 4

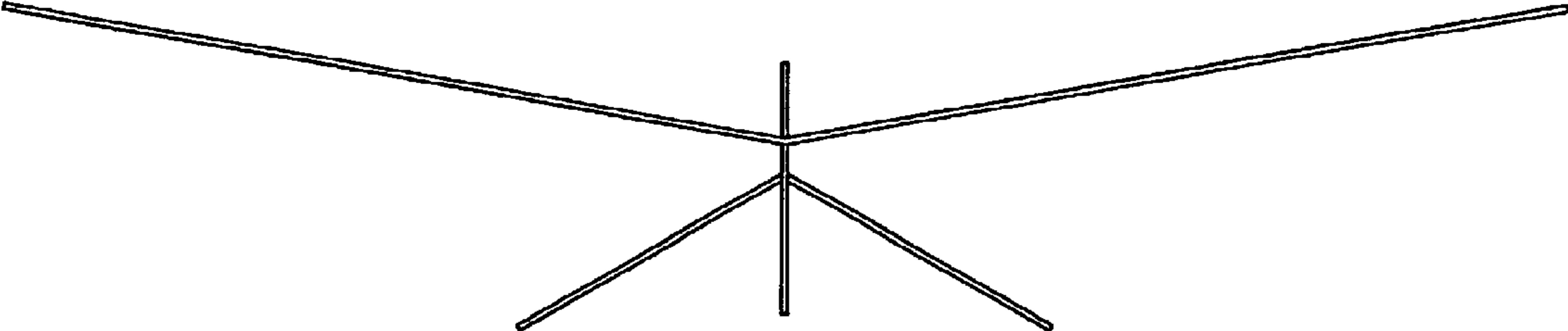

FIG. 5

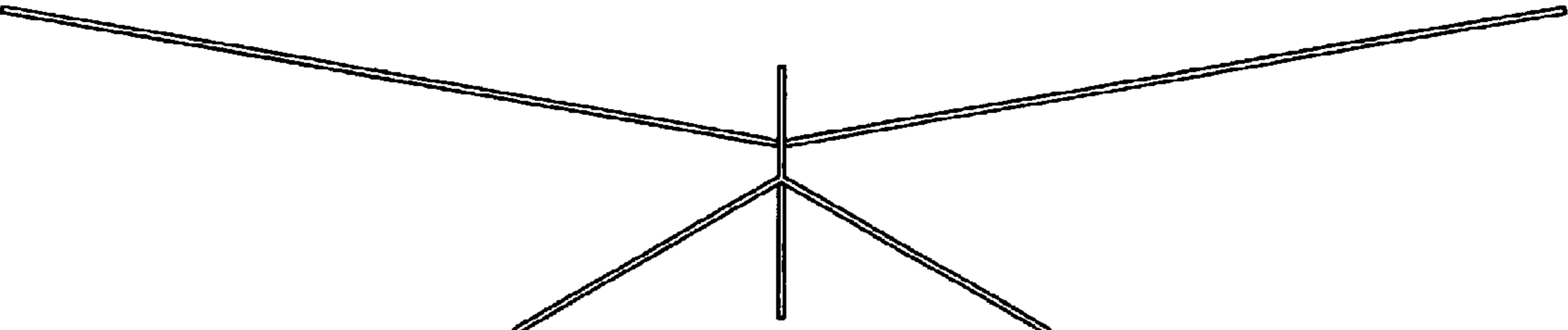

FIG. 6