

US00D492628S1

(12) **United States Design Patent** (10) **Patent No.:** **US D492,628 S**
Bond et al. (45) **Date of Patent:** **** Jul. 6, 2004**

(54) **BUMPER**

(75) Inventors: **Eric Bond**, High Point, NC (US);
Ruben Perfetti, Greensboro, NC (US);
John Martin, Madison, NC (US)

(73) Assignee: **Volvo Trucks North America, Inc.**,
Greensboro, NC (US)

(**) Term: **14 Years**

(21) Appl. No.: **29/186,817**

(22) Filed: **Jul. 22, 2003**

(51) **LOC (7) Cl.** **12-16**

(52) **U.S. Cl.** **D12/169**

(58) **Field of Search** D12/169, 196,
D12/90-92; 293/102, 113, 115, 117, 120;
296/180.1, 180.2

(56) **References Cited**

U.S. PATENT DOCUMENTS

D445,073 S	*	7/2001	Tirey et al.	D12/169
D458,565 S	*	6/2002	Maher et al.	D12/169
D476,929 S	*	7/2003	Dozier et al.	D12/169
D482,302 S	*	11/2003	Dozier et al.	D12/169
D483,707 S	*	12/2003	Satou	D12/169

OTHER PUBLICATIONS

1 page section of a story board used by the inventors of the present application depicting competing trucks, Date: At least as early as Dec. 31, 1999.

* cited by examiner

Primary Examiner—Melody N. Brown
(74) *Attorney, Agent, or Firm*—Watts Hoffmann Co., L.P.A.

(57) **CLAIM**

We claim the ornamental design for a bumper, as shown and described.

DESCRIPTION

FIG. 1 is a perspective view of the bumper of our new design;

FIG. 2 is a perspective view of the bumper of FIG. 1;

FIG. 3 is a top plan view of the bumper of FIG. 1;

FIG. 4 is a left side elevational view of the bumper of FIG. 1;

FIG. 5 is a front elevational view of the bumper of the bumper of FIG. 1;

FIG. 6 is a right side elevational view of the bumper of FIG. 1

FIG. 7 is a rear elevational view of the bumper of FIG. 1; and,

FIG. 8 is a bottom plan view of the bumper of FIG. 1.

The broken lines shown are for illustrative purposes only and form no part of the claimed design.

1 Claim, 4 Drawing Sheets

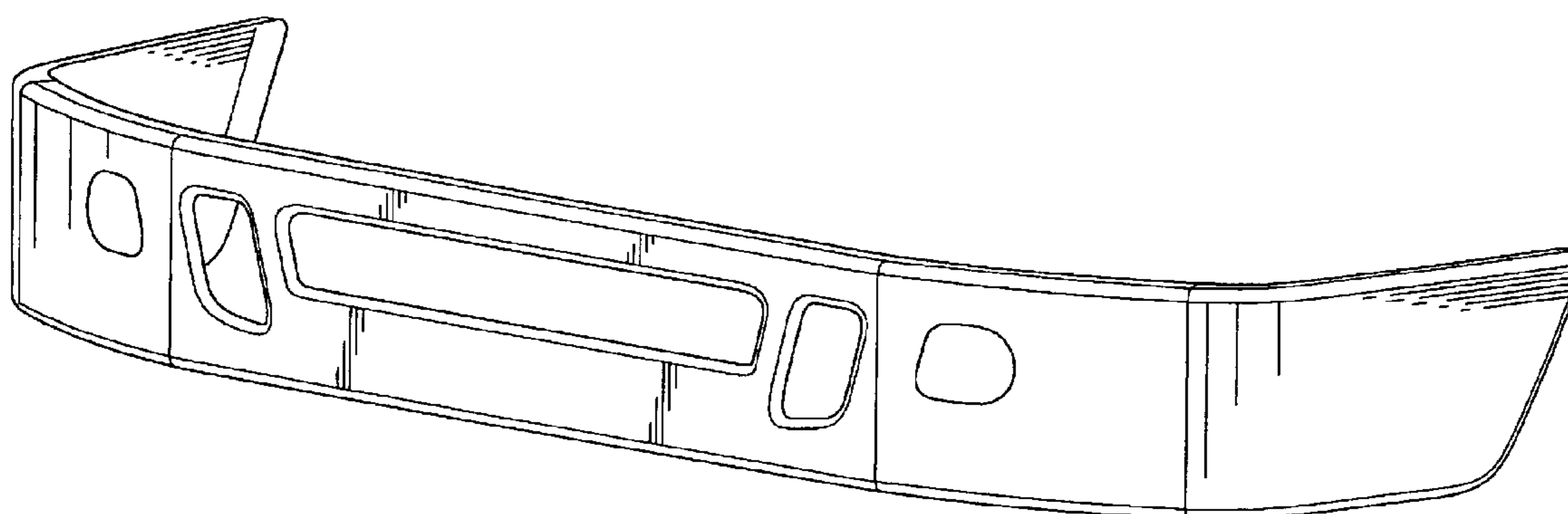

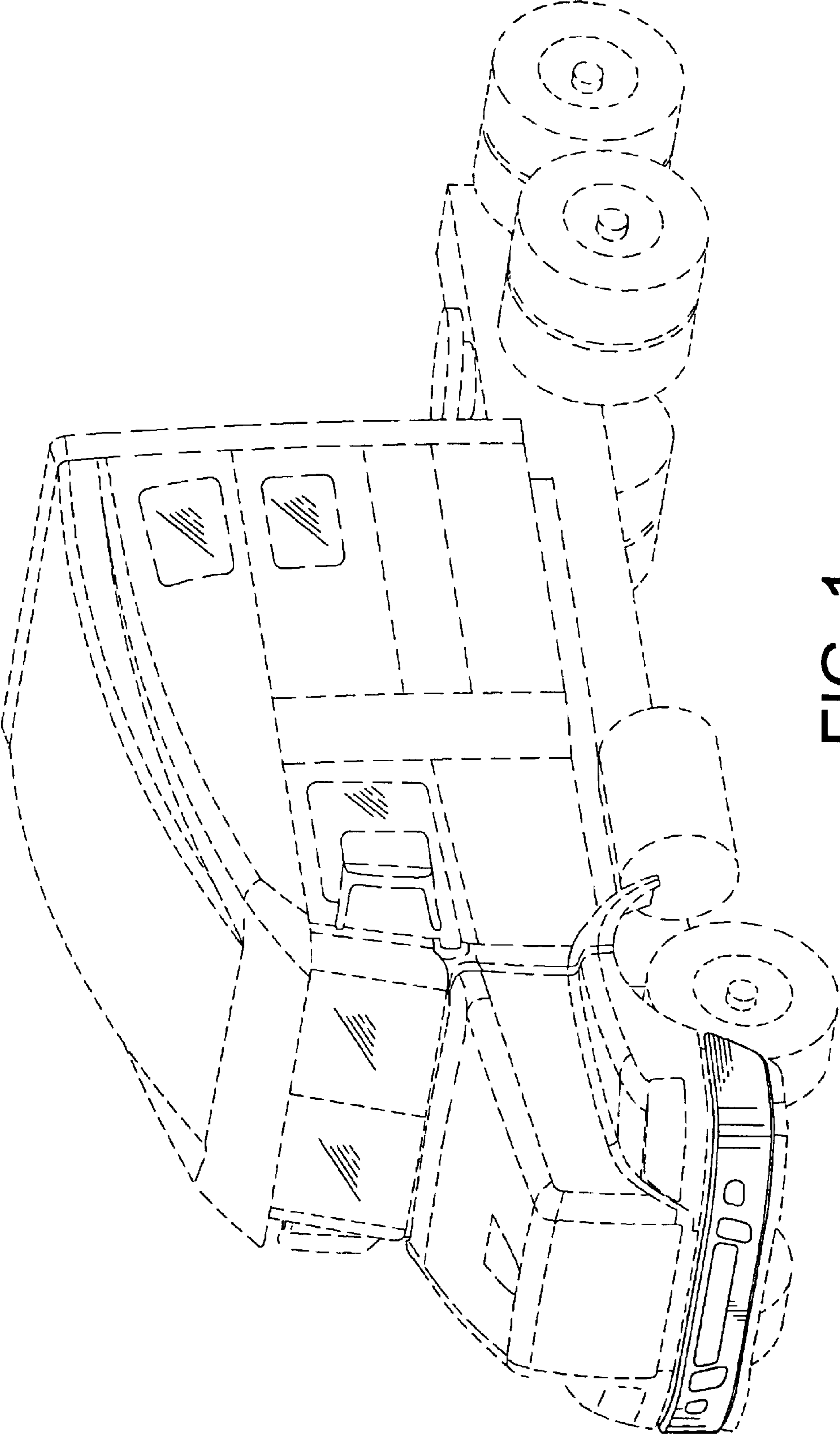

FIG. 1

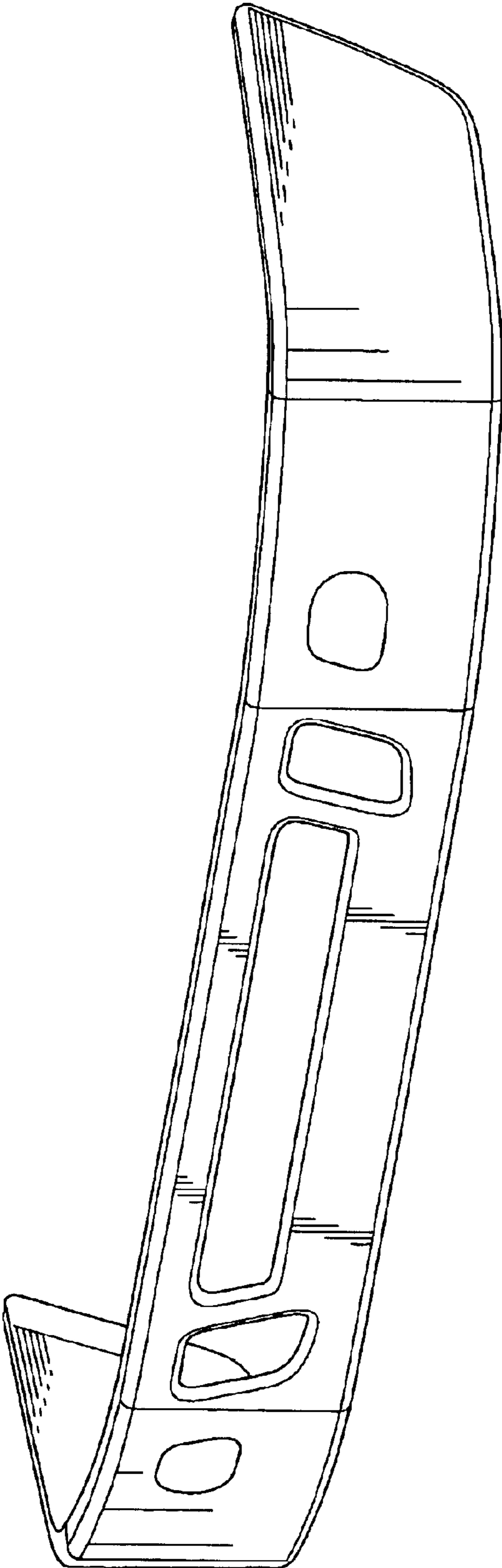

FIG. 2

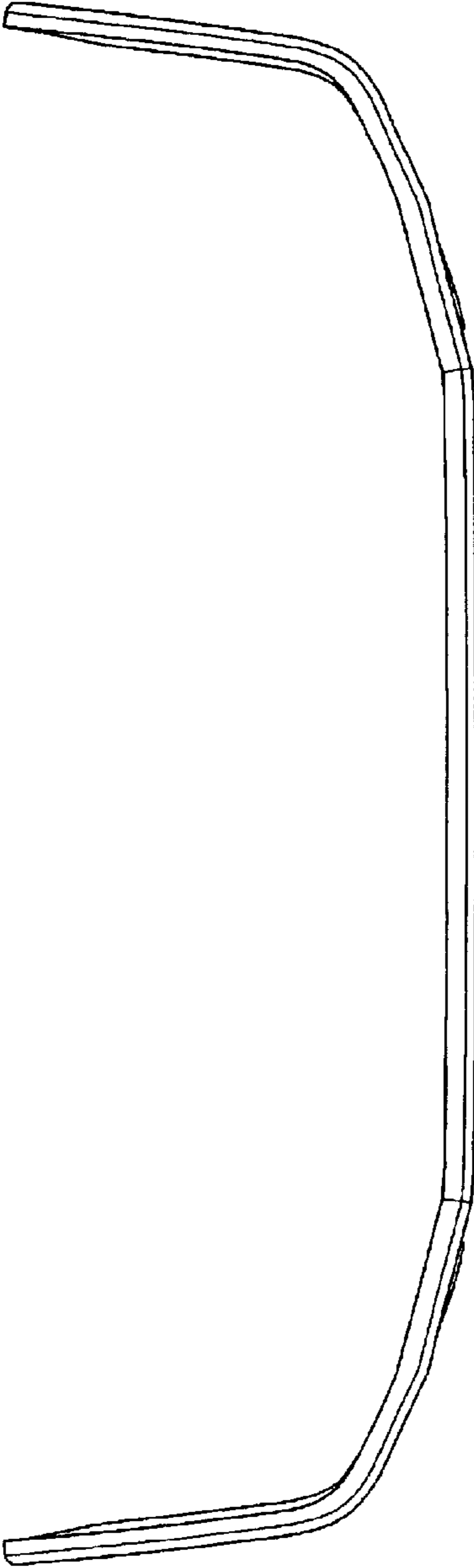

FIG. 3

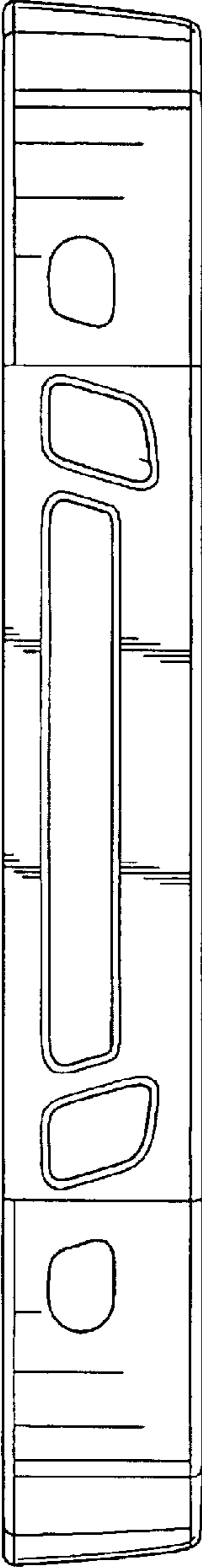

FIG. 5

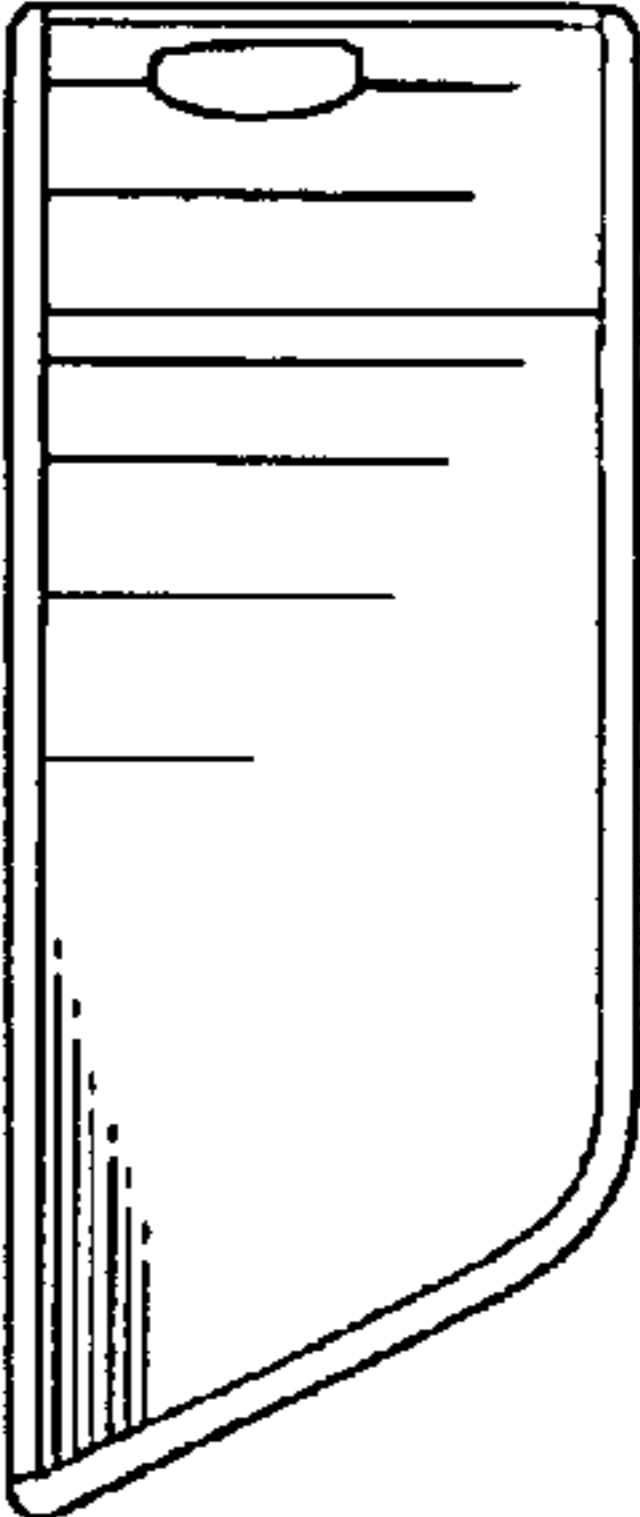

FIG. 4

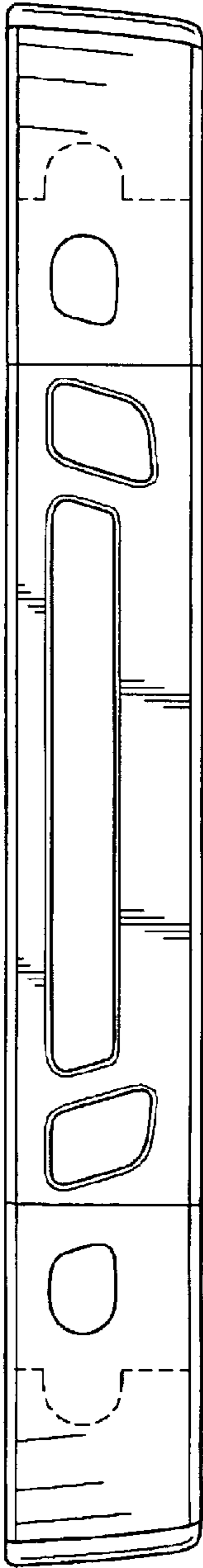

FIG. 6

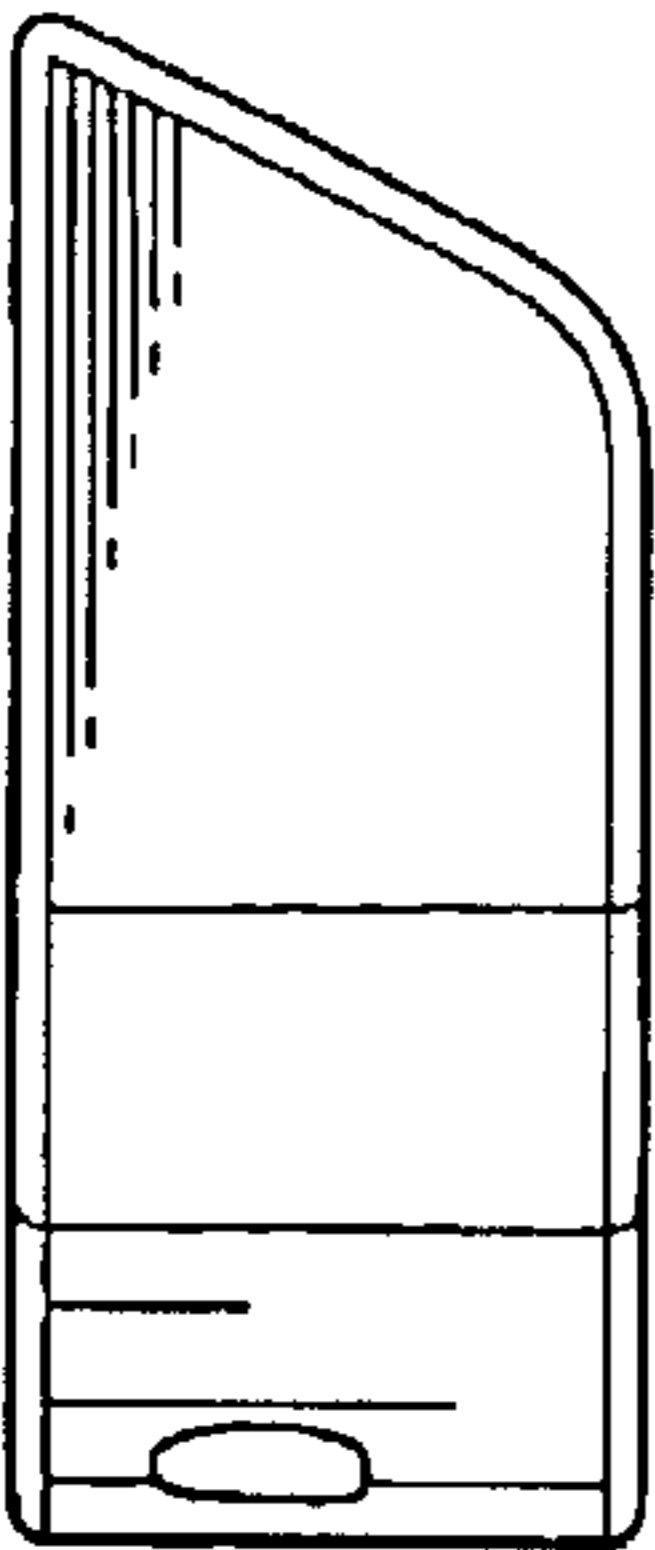

FIG. 7

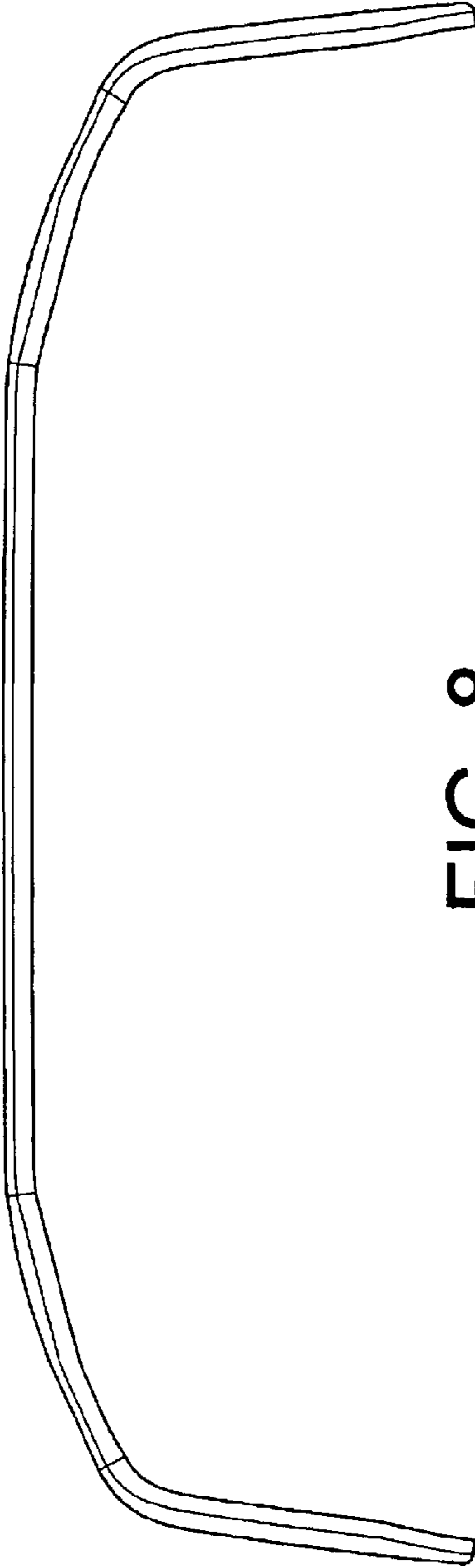

FIG. 8