

US00D492608S1

(12) **United States Design Patent**  
**Fujioka**

(10) **Patent No.:** **US D492,608 S**  
(45) **Date of Patent:** **\*\* Jul. 6, 2004**

(54) **TIRE PRESSURE GAUGE**

(75) Inventor: **Juzo Fujioka**, Hyogo Pref. (JP)

(73) Assignees: **Kabushiki Kaisha Piyo**, Kobe (JP);  
**G.H. Meiser Co.**, Posen, IL (US)

(\*\*) Term: **14 Years**

(21) Appl. No.: **29/189,386**

(22) Filed: **Sep. 4, 2003**

(30) **Foreign Application Priority Data**

May 30, 2003 (JP) ..... 2003-015214

(51) **LOC (7) Cl.** ..... **10-04**

(52) **U.S. Cl.** ..... **D10/86**

(58) **Field of Search** ..... D10/86, 85; 73/146.3,  
73/146.8; 116/34 R; 702/140

(56) **References Cited**

**U.S. PATENT DOCUMENTS**

- 5,394,343 A \* 2/1995 Tsao ..... 702/140
- D409,931 S \* 5/1999 Petrucelli et al. .... D10/86
- D440,894 S \* 4/2001 Van Zeyl ..... D10/86
- D441,674 S \* 5/2001 Van Zeyl ..... D10/86
- D459,257 S \* 6/2002 Petrucelli ..... D10/86

D472,172 S \* 3/2003 Fujioka et al. .... D10/86

\* cited by examiner

*Primary Examiner*—Lucy Lieberman

*Assistant Examiner*—L. Williams

(74) *Attorney, Agent, or Firm*—Marshall, Gerstein & Borun  
LLP

(57) **CLAIM**

The ornamental design for a tire pressure gauge, as shown and described.

**DESCRIPTION**

FIG. 1 is a front elevational view of a tire pressure gauge in accordance with the present invention;  
 FIG. 2 is a rear elevational view thereof;  
 FIG. 3 is a top plan view thereof;  
 FIG. 4 is a bottom plan view thereof;  
 FIG. 5 is a right-side elevational view thereof;  
 FIG. 6 is a left-side elevational view thereof;  
 FIG. 7 is a perspective view thereof.  
 FIG. 8 is an enlarged cross sectional view showing the cut walls of the tire pressure gauge taken along the lline 8—8 in the direction of the arrows in FIGS. 1 and 3; and,  
 FIG. 9 is an enlarged fragmentary top plan view of the right end of the tire pressure gauge.

**1 Claim, 6 Drawing Sheets**

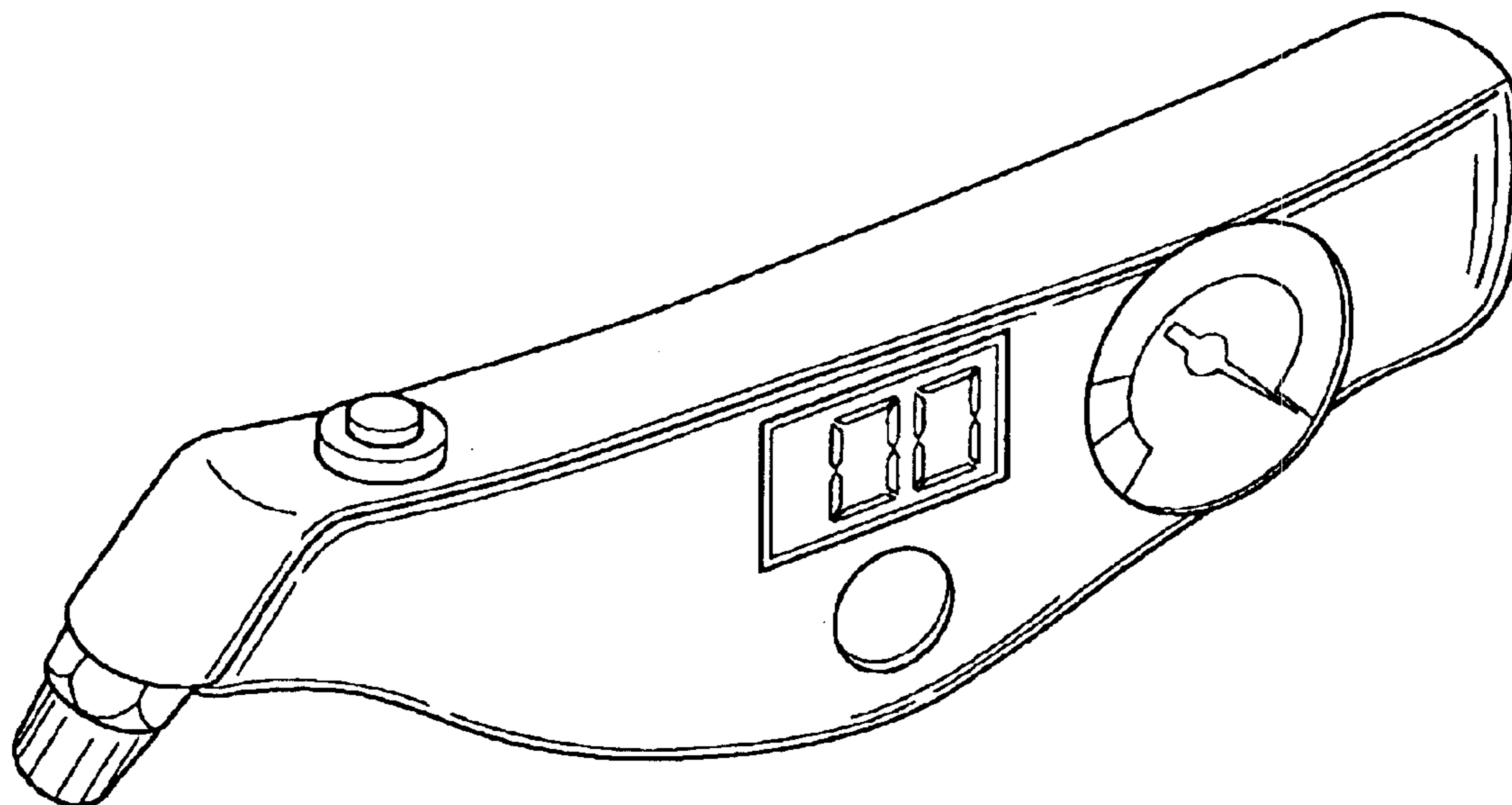
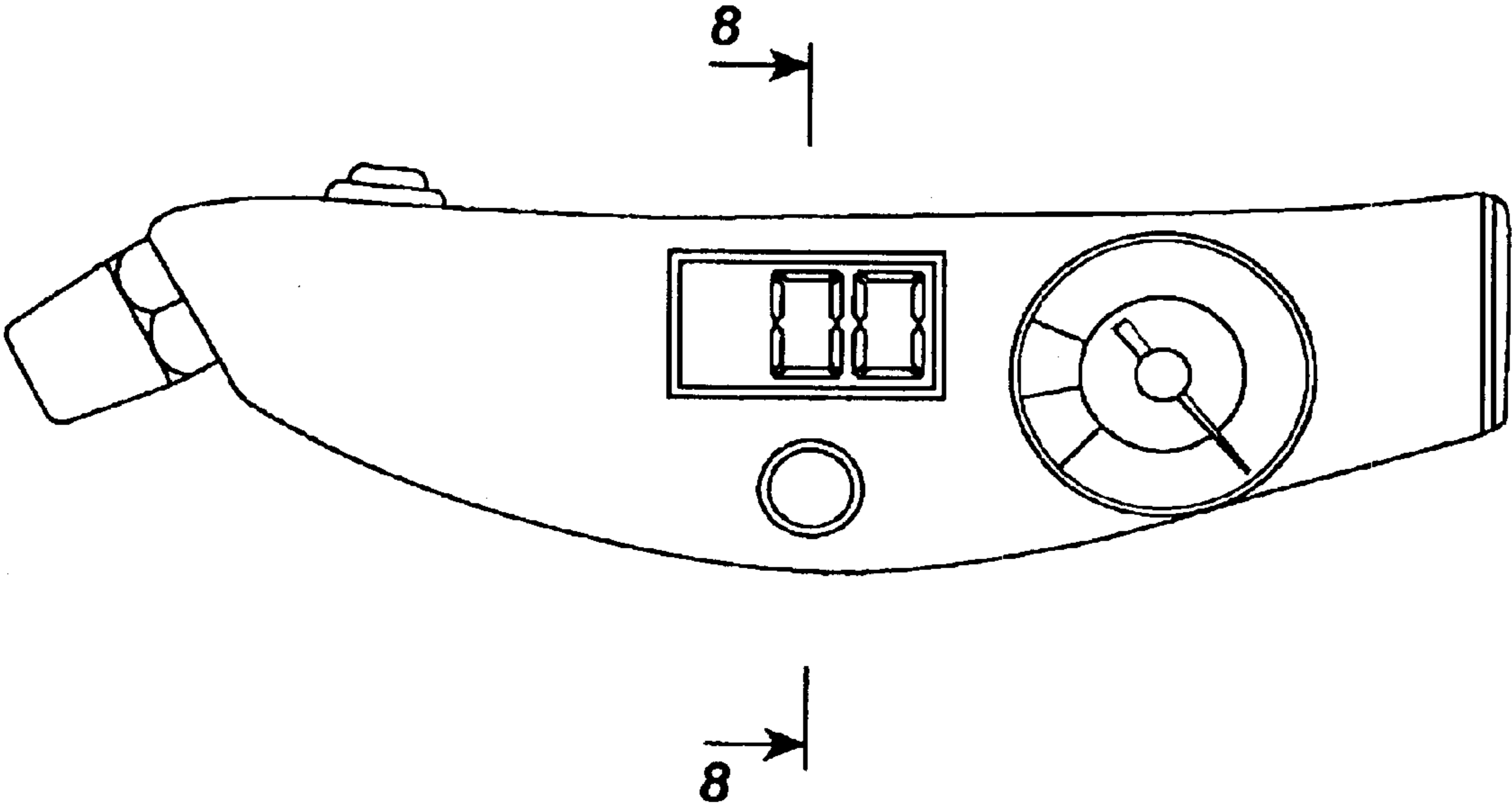
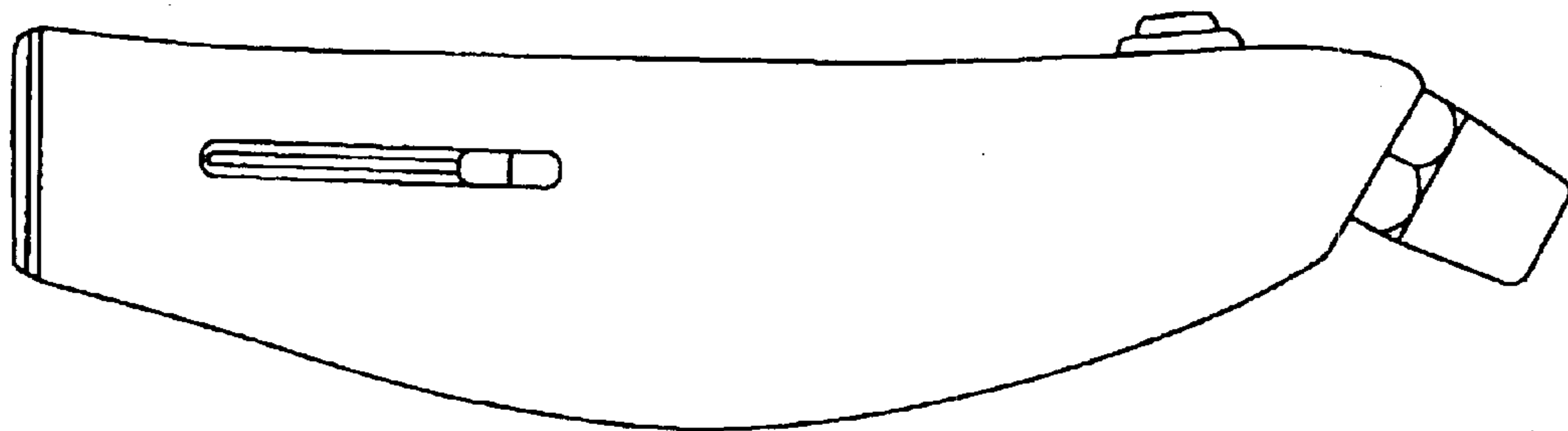

FIG. 1



**FIG. 2**



**FIG. 3**

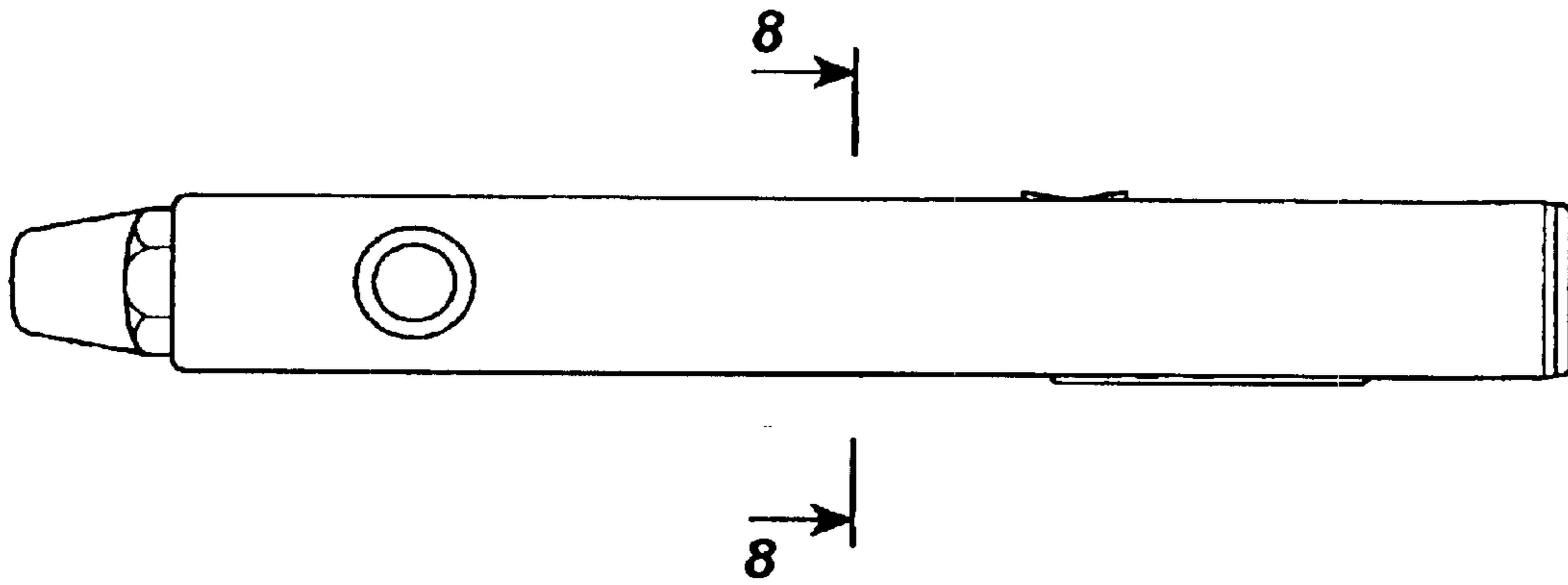

**FIG. 4**

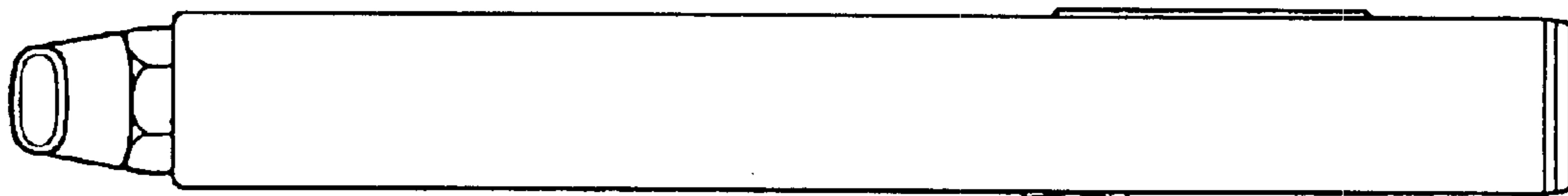

**FIG. 5**

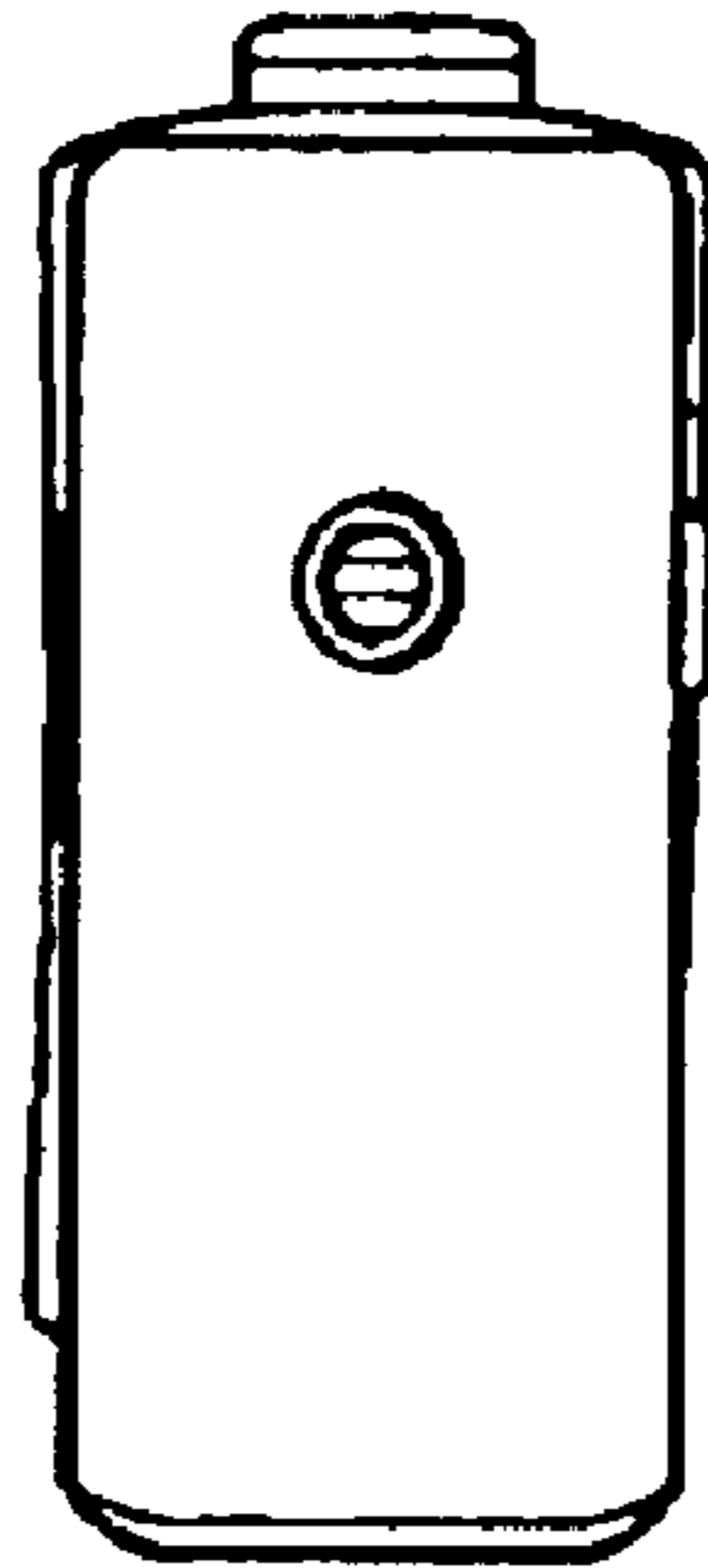

**FIG. 6**

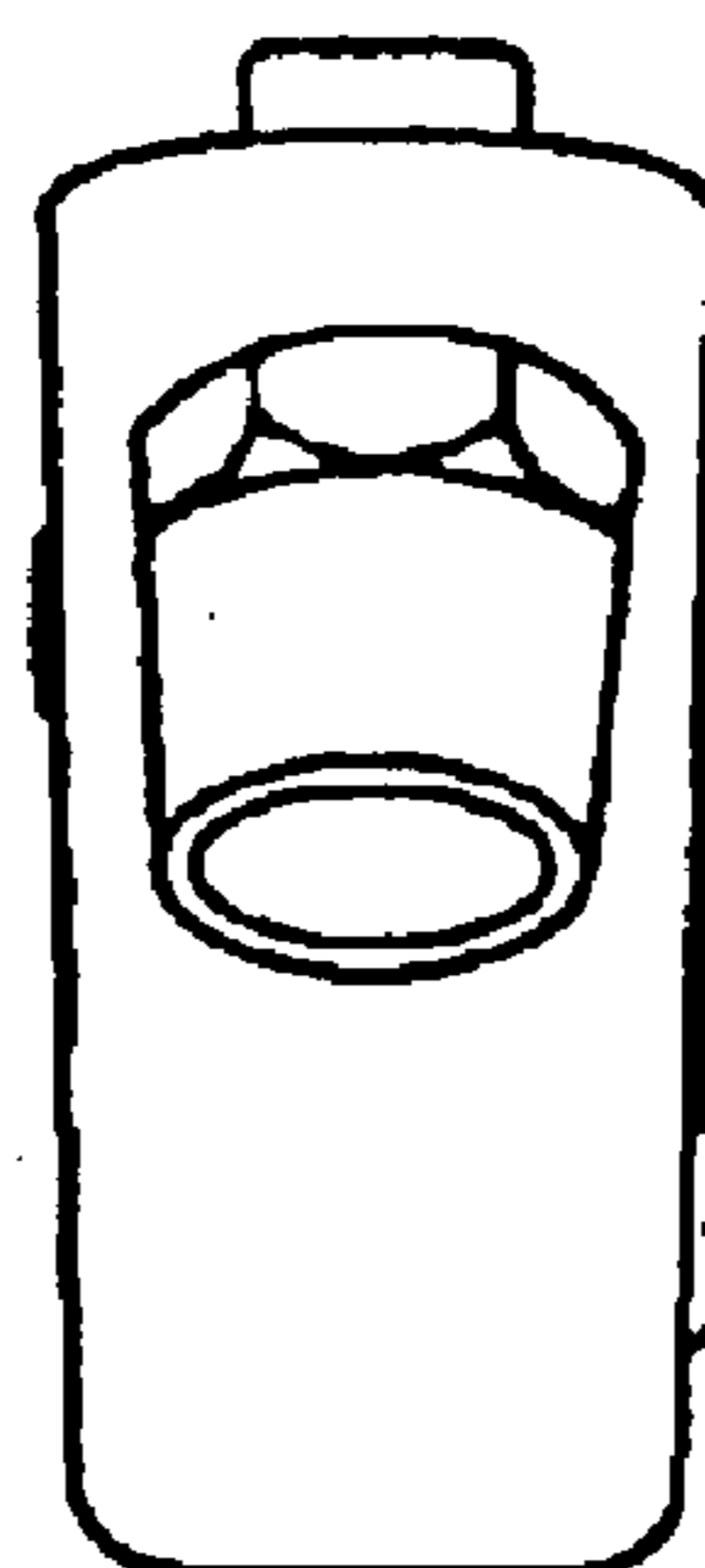

**FIG. 7**

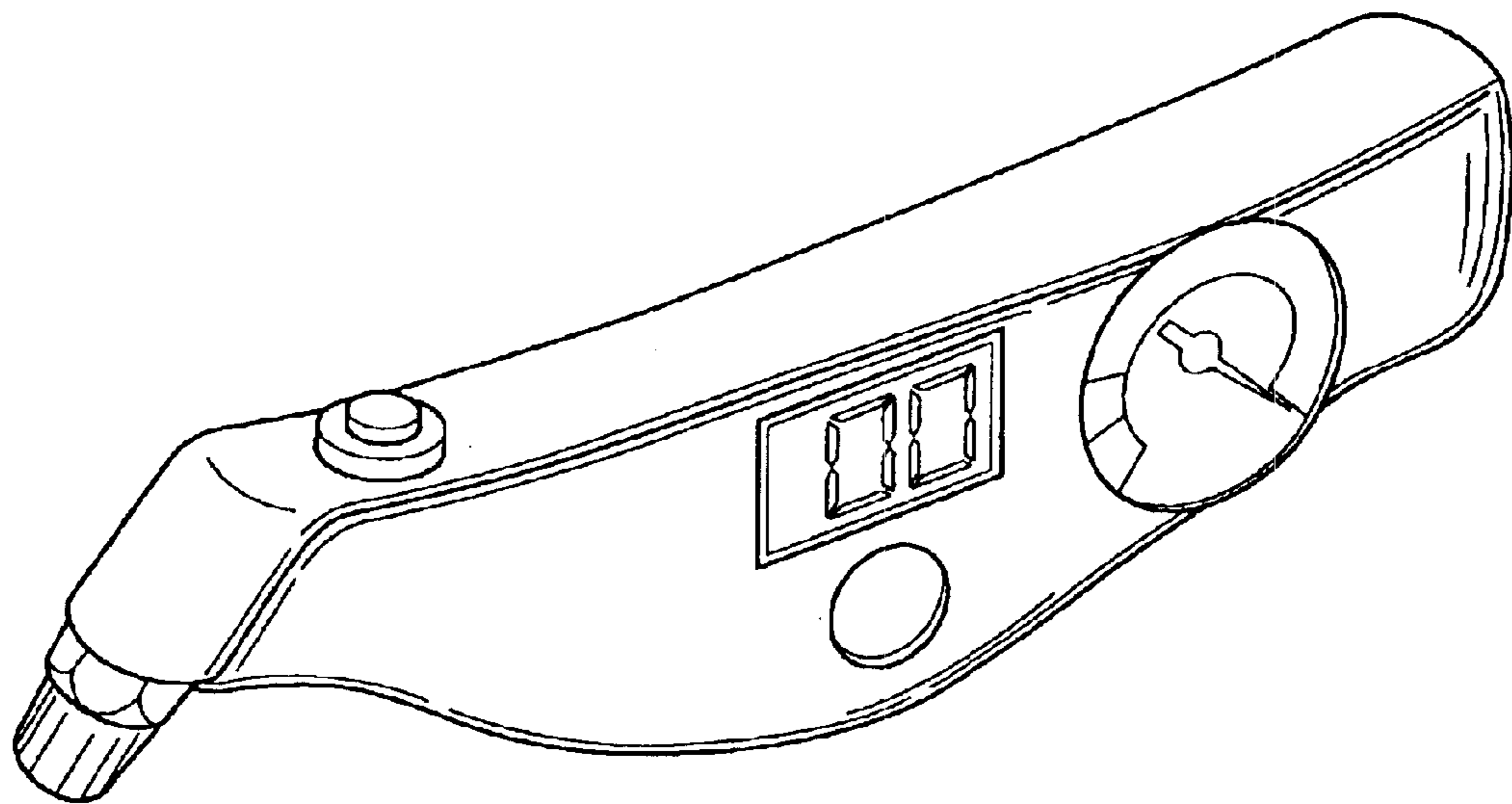

**FIG. 8**

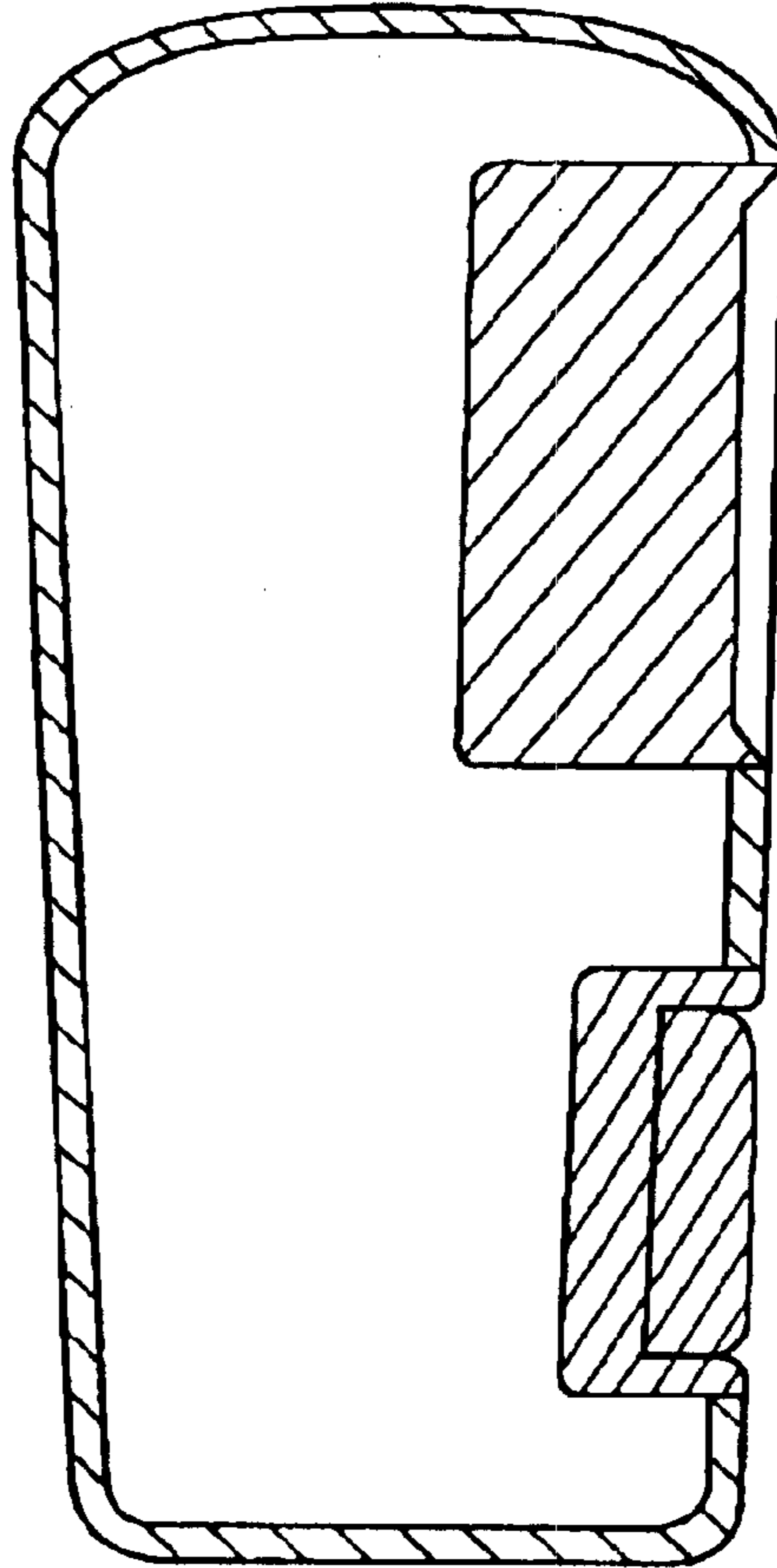

**FIG. 9**

