



US00D492228S1

(12) **United States Design Patent**  
**Hara et al.**

(10) **Patent No.:** **US D492,228 S**  
(45) **Date of Patent:** **\*\* Jun. 29, 2004**

(54) **AUTOMOBILE BUMPER**

(75) Inventors: **Hisao Hara**, Aichi-ken (JP); **Kuniaki Toyooka**, Aichi-ken (JP)

(73) Assignee: **Toyota Jidosha Kabushiki Kaisha**, Aichi-ken (JP)

(\*\*) Term: **14 Years**

(21) Appl. No.: **29/186,672**

(22) Filed: **Jul. 22, 2003**

(51) **LOC (7) Cl.** ..... **12-16**

(52) **U.S. Cl.** ..... **D12/169**

(58) **Field of Search** ..... D12/169, 196,  
D12/90-92; 293/102, 113, 115, 117, 120;  
296/180.1, 180.2

(56) **References Cited**

**U.S. PATENT DOCUMENTS**

D462,640 S	*	9/2002	Sakae	.....	D12/169
D463,334 S	*	9/2002	Koman	.....	D12/169
D473,168 S	*	4/2003	Hayashi	.....	D12/169
D473,500 S	*	4/2003	Okumoto et al.	.....	D12/169
D474,720 S	*	5/2003	Tachibana et al.	.....	D12/169
D475,958 S	*	6/2003	Yokomaku	.....	D12/196

**OTHER PUBLICATIONS**

Brochure of NADIA, (Mfg.—Toyota Jidosha Kabushiki Kaisha), Jul. 2002.  
Automotive Guidebook of Japan, vol. 49, “MPV,” (Mfg.—Mazda Motor Corporation), Oct. 29, 2002.

\* cited by examiner

*Primary Examiner*—Melody N. Brown  
(74) *Attorney, Agent, or Firm*—Finnegan, Henderson, Farabow, Garrett & Dunner, L.L.P.

(57) **CLAIM**

The ornamental design for an automobile bumper, as shown and described.

**DESCRIPTION**

FIG. 1 is a left-front, perspective view of an automobile bumper of our new design;

FIG. 2 is a front view of our new design;

FIG. 3 is a rear view of our new design;

FIG. 4 is a top view of our new design;

FIG. 5 is a bottom view of our new design;

FIG. 6 is a left-side view our new design, the right-side view being a mirror image thereof;

FIG. 7 is a cross-sectional view of our new design taken along the line 7—7 in FIG. 2, showing the profile of that portion of the design;

FIG. 8 is a cross-sectional view of our new design taken along the line 8—8 in FIG. 2, showing the profile of that portion of the design; and,

FIG. 9 is a cross-sectional view of our new design taken along the line 9—9 in FIG. 2, showing the profile of that portion of the design.

**1 Claim, 5 Drawing Sheets**

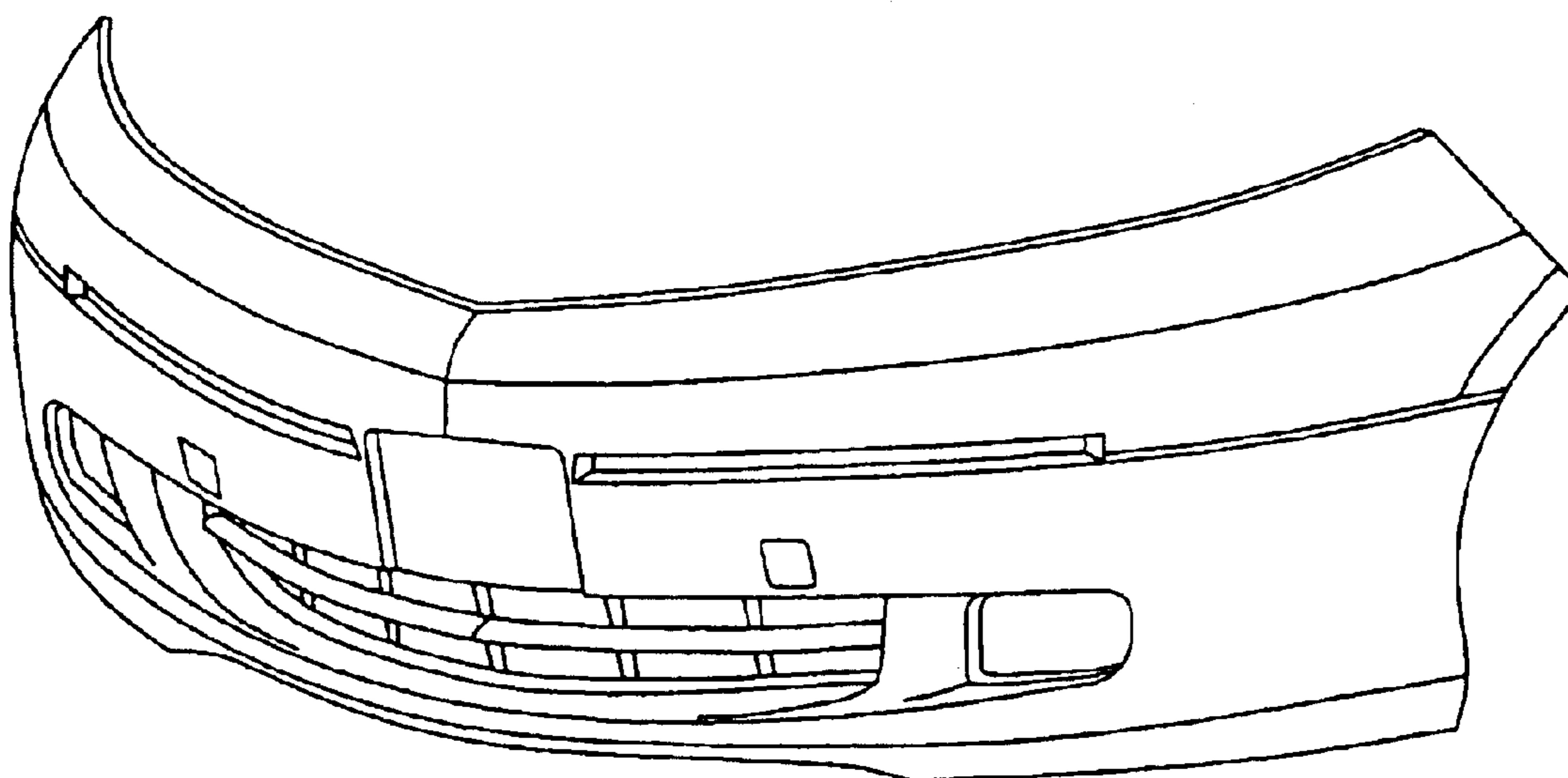

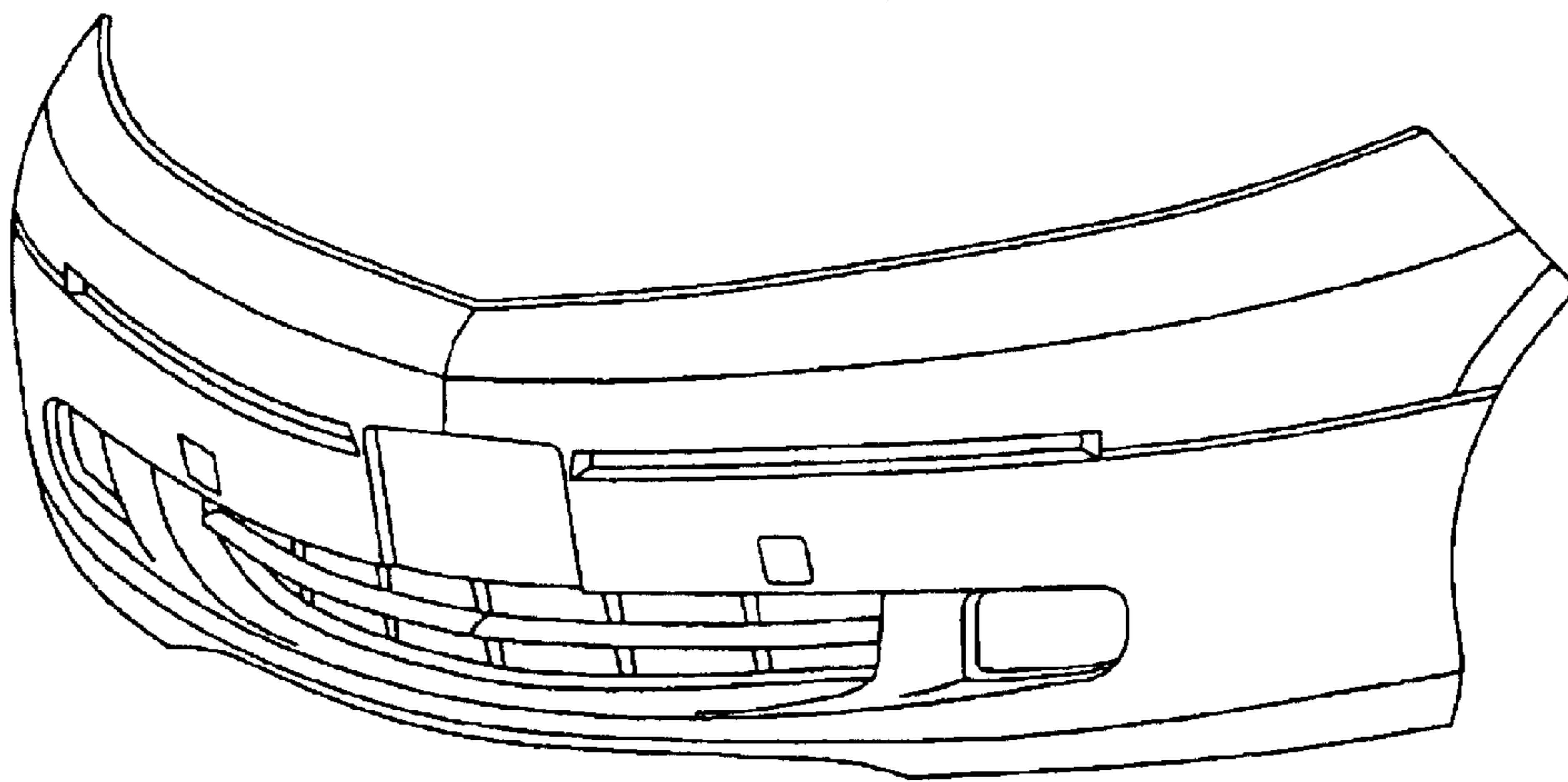

FIG. 1

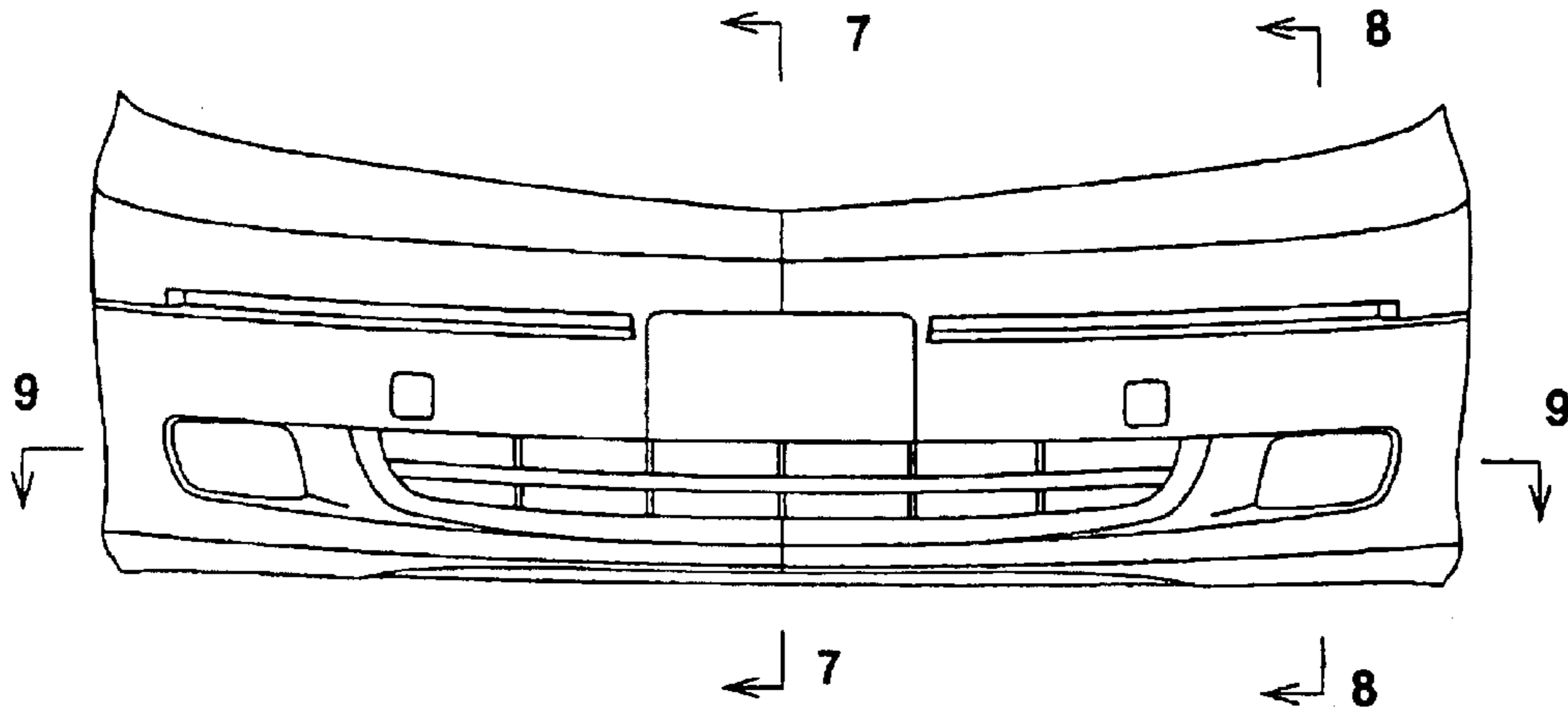

FIG. 2

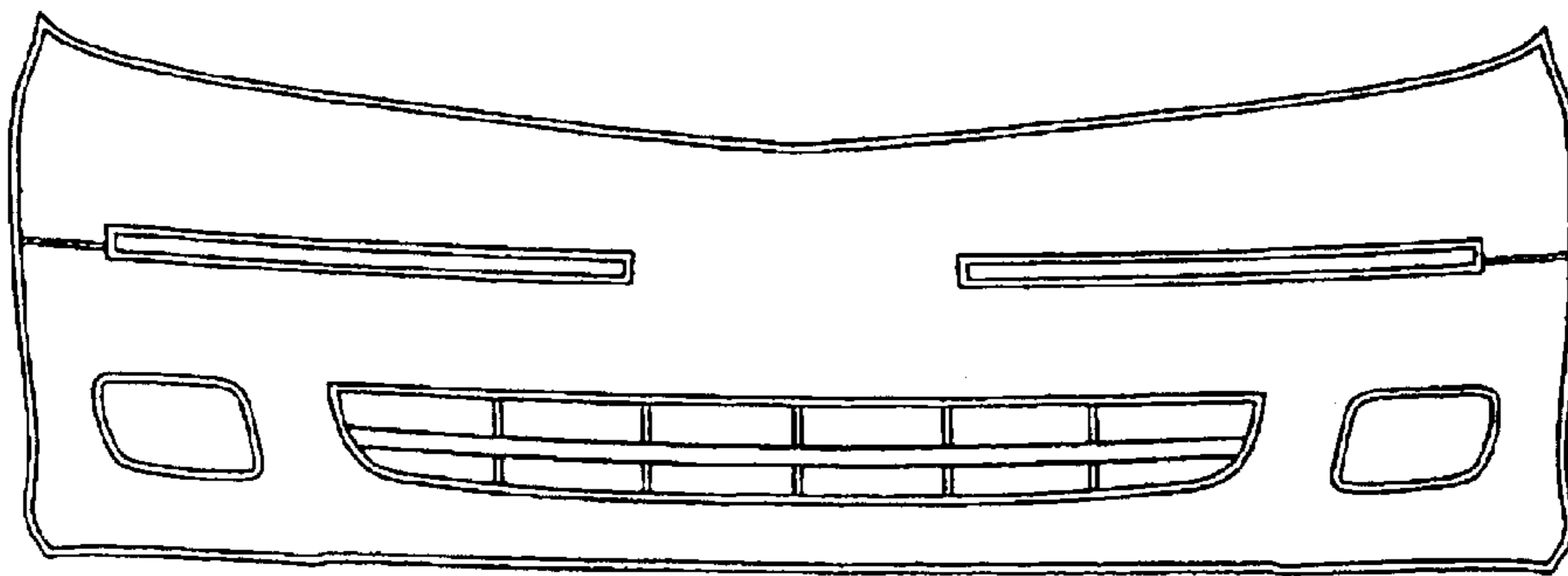

FIG. 3

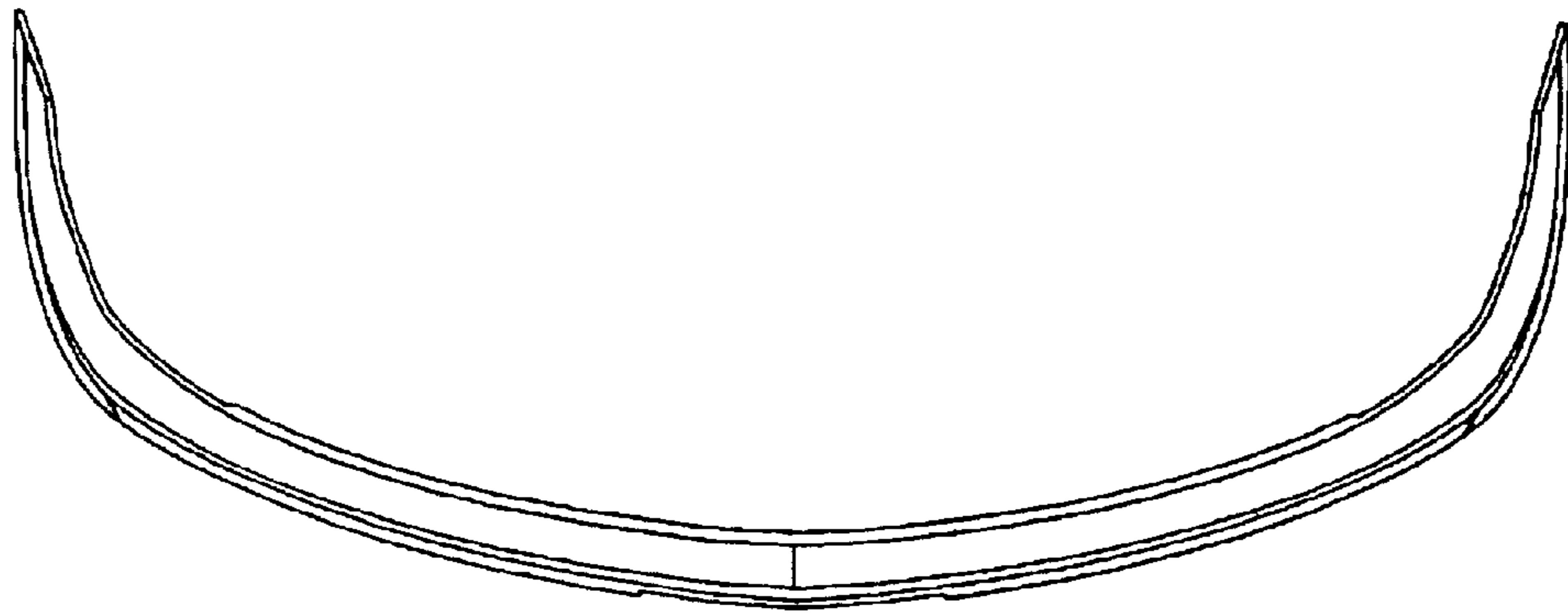

FIG. 4

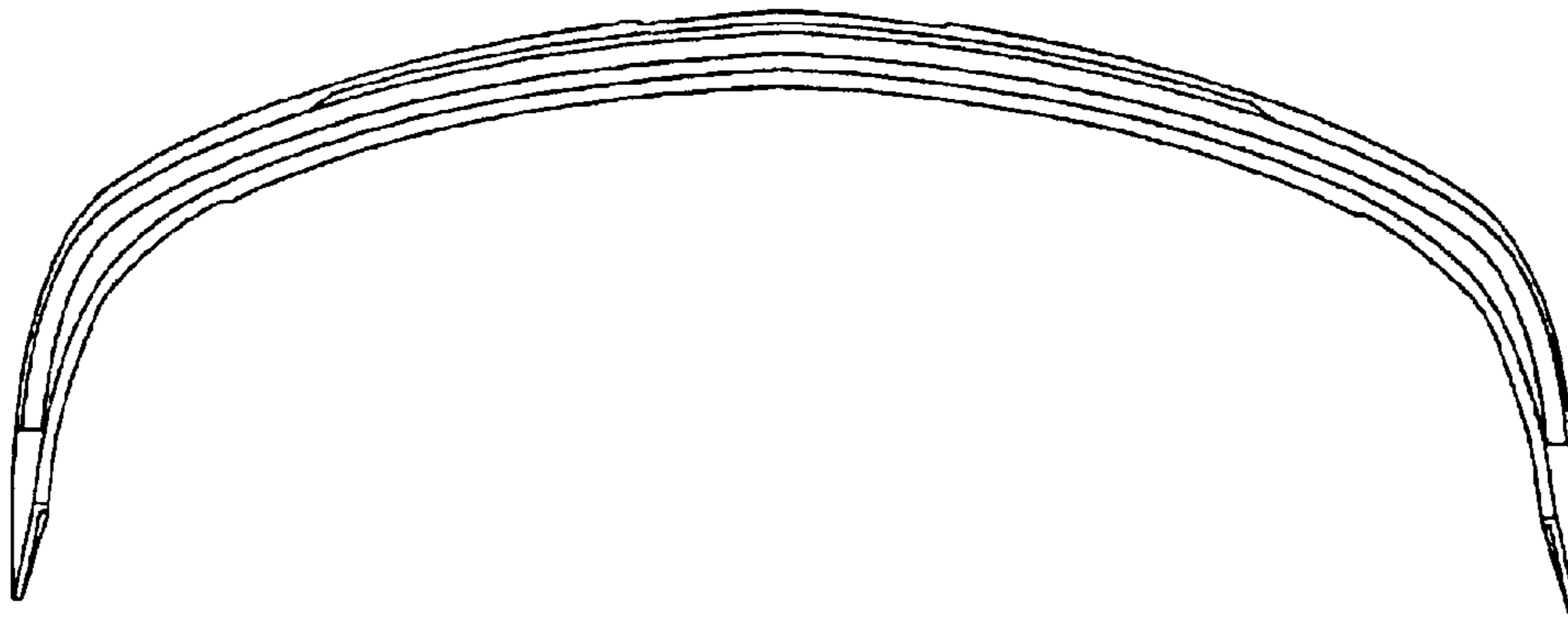

FIG. 5

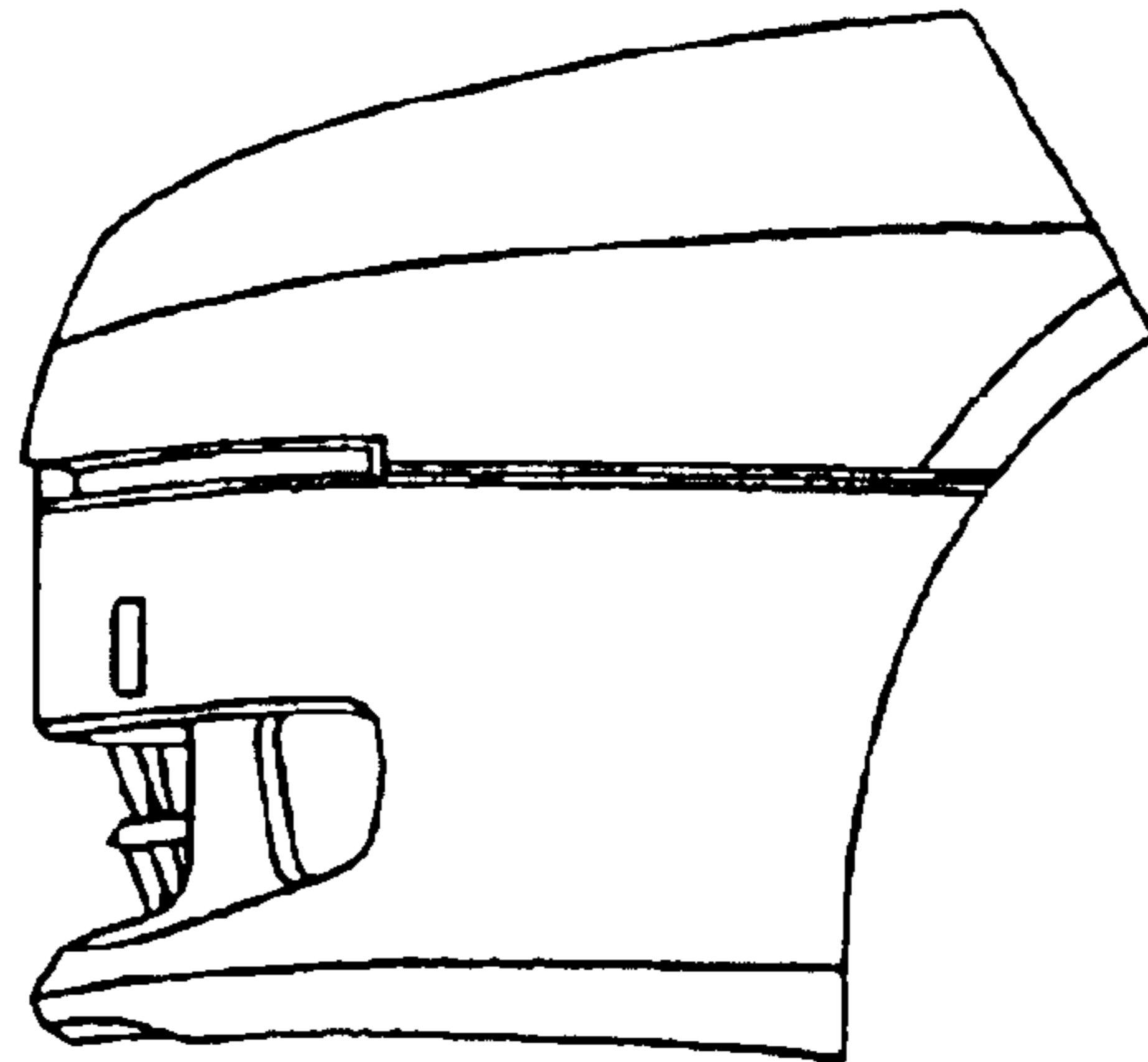

FIG. 6

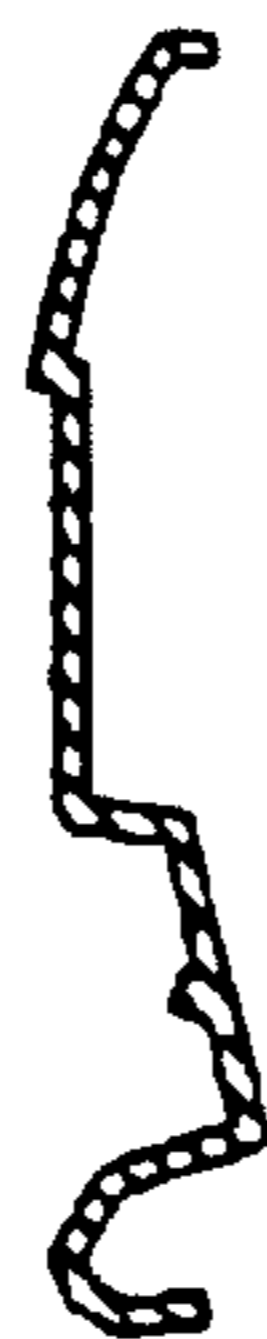

FIG. 7

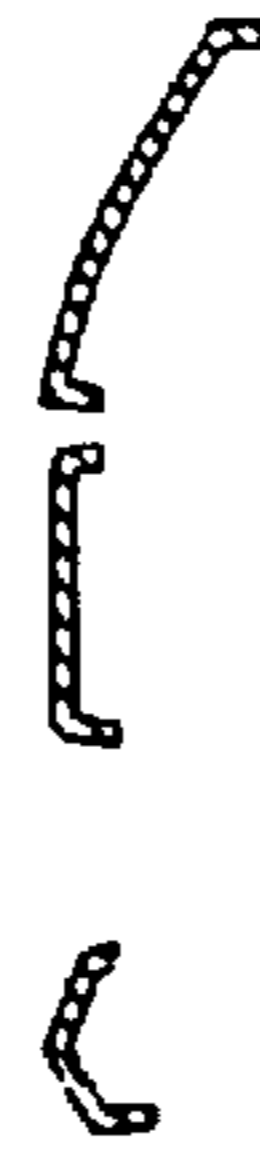

FIG. 8

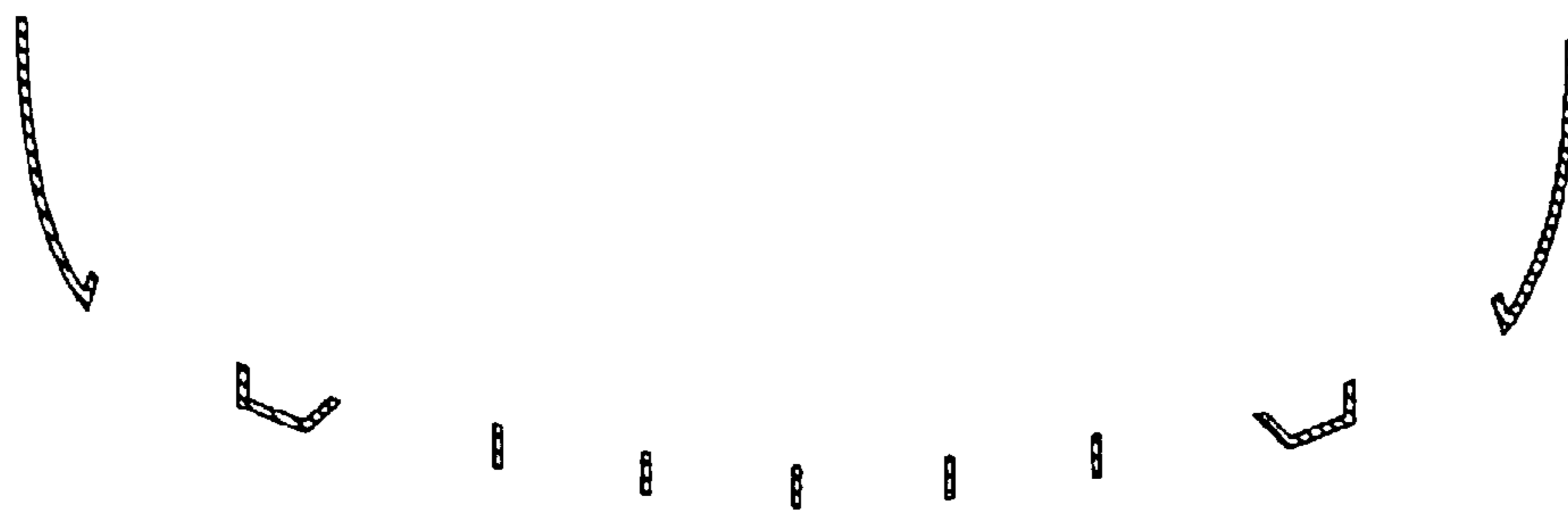

FIG. 9