



US00D492225S1

(12) **United States Design Patent**  
**Savage**

(10) **Patent No.:** **US D492,225 S**

(45) **Date of Patent:** **\*\* Jun. 29, 2004**

(54) **MOTORCYCLE MASTER CYLINDER HOUSING**

(75) Inventor: **Frank Savage**, Trenton, WI (US)

(73) Assignee: **Harley Davidson Motor Company Group, Inc.**, Milwaukee, WI (US)

(\*\*) Term: **14 Years**

(21) Appl. No.: **29/177,080**

(22) Filed: **Mar. 3, 2003**

(51) **LOC (7) Cl.** ..... **12-11**

(52) **U.S. Cl.** ..... **D12/126**

(58) **Field of Search** ..... D12/110, 114,  
D12/126, 180; 180/219; 280/288.4, 304.3;  
188/152, 344, 345; 60/588, 592, 594

(56) **References Cited**  
**PUBLICATIONS**

V-TWIN, 1993 Uniquely V-Twin Manufacturing Catalog, p. 190, published prior to Jan. 1, 1994.  
HARLEY-DAVIDSON, 1993-94 Sportster Five-Speed/Belt Drive Parts Catalog—All Models, Part No. 99451-94, p. 42, published prior to Jan. 1, 1994.  
CUSTOM CHROME, 94 Custom Chrome Catalog, p. 478, published prior to Jan. 1, 1995.  
HARLEY-DAVIDSON, 1996 Harley-Davidson Genuine Motor Accessories and Genuine Motor Parts Catalog, Soft-tail, p. 78; Touring, p. 108; and non-numbered page, published prior Jan. 1, 1997.

CUSTOM CHROME, Winter '98 Catalog, p. 18.32, published prior to Jan. 1, 1999.

*Primary Examiner*—Alan P. Douglas

*Assistant Examiner*—Linda Brooks

(74) *Attorney, Agent, or Firm*—Michael Best & Friedrich LLP

(57) **CLAIM**

I claim the ornamental design for a motorcycle master cylinder housing, as shown and described.

**DESCRIPTION**

FIG. 1 is a perspective view of a motorcycle master cylinder housing according to the invention;

FIG. 2 is top view of the motorcycle master cylinder housing of FIG. 1;

FIG. 3 is a front view of the motorcycle master cylinder housing of FIG. 1;

FIG. 4 is a side view of the motorcycle master cylinder housing of FIG. 1;

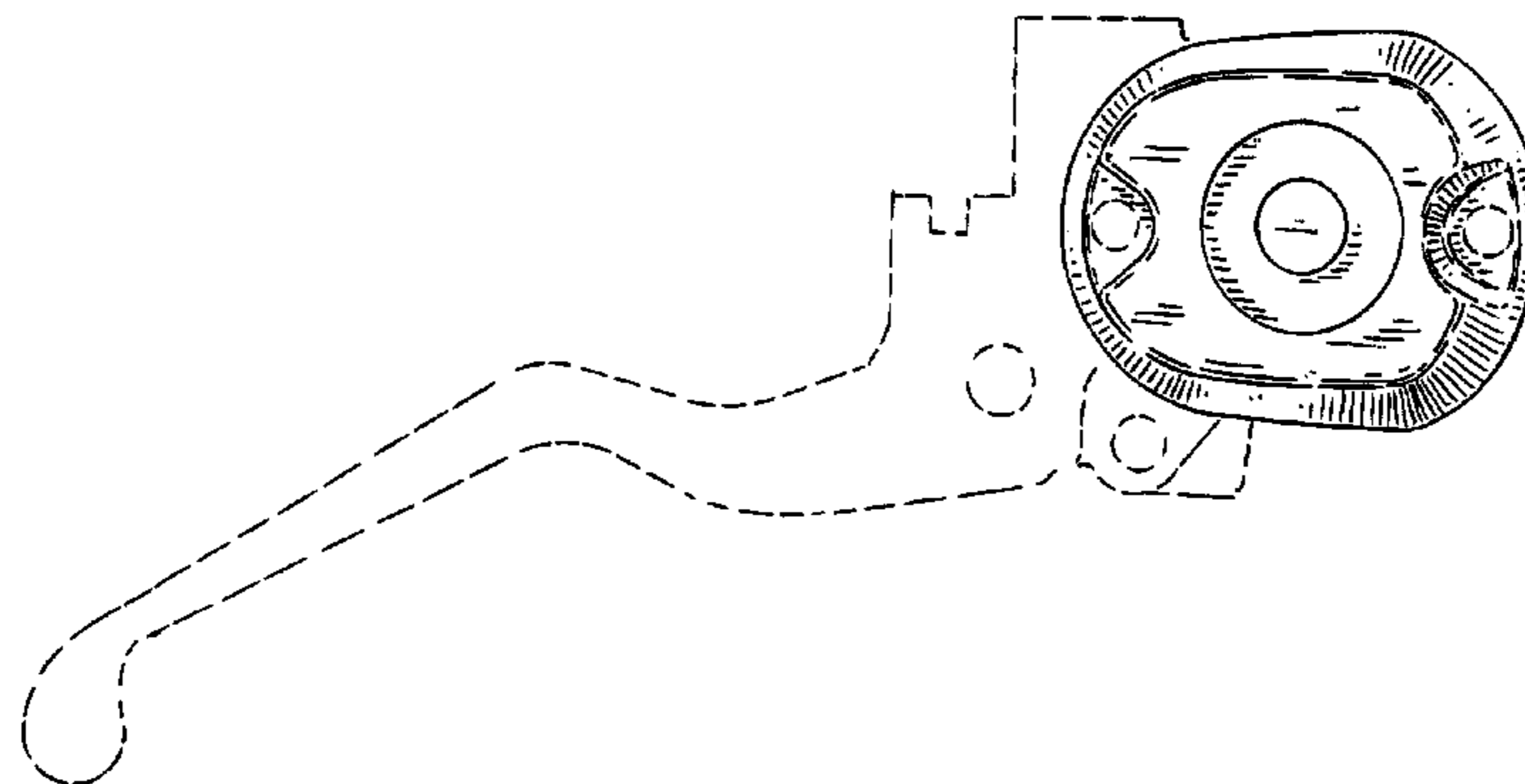
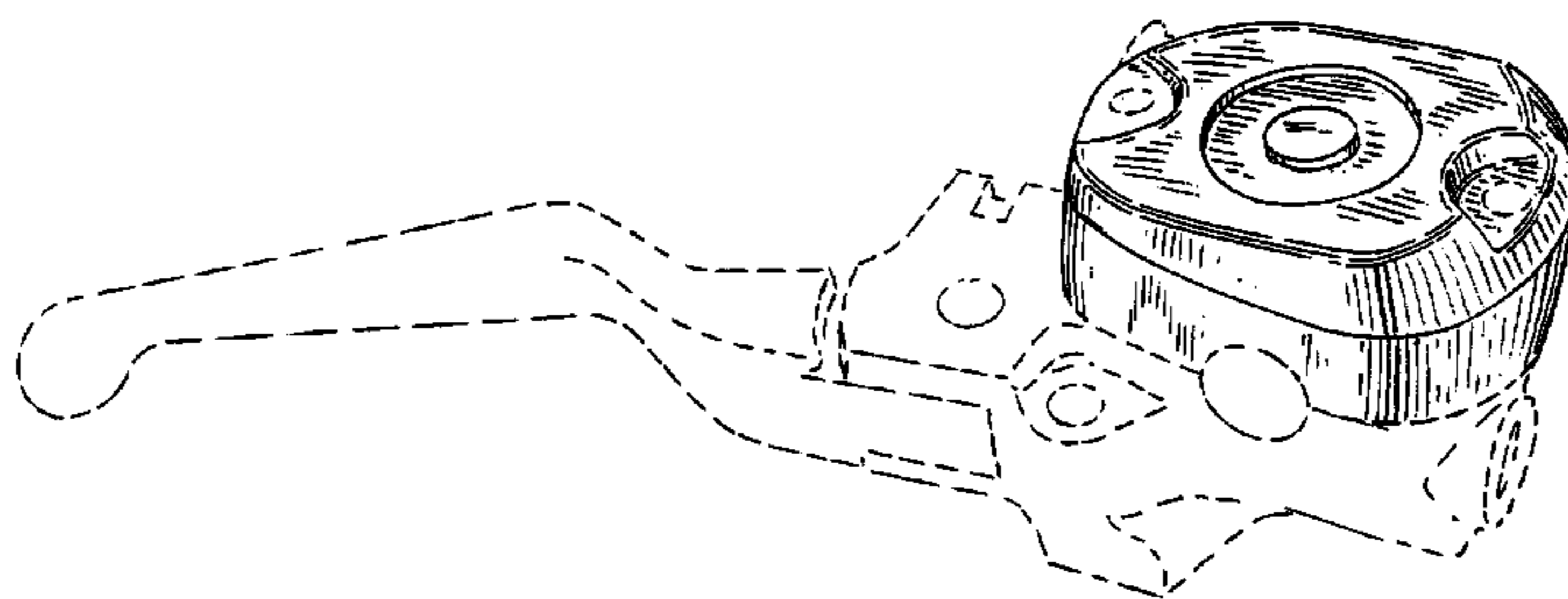
FIG. 5 is an opposite side view of the motorcycle master cylinder housing of FIG. 1;

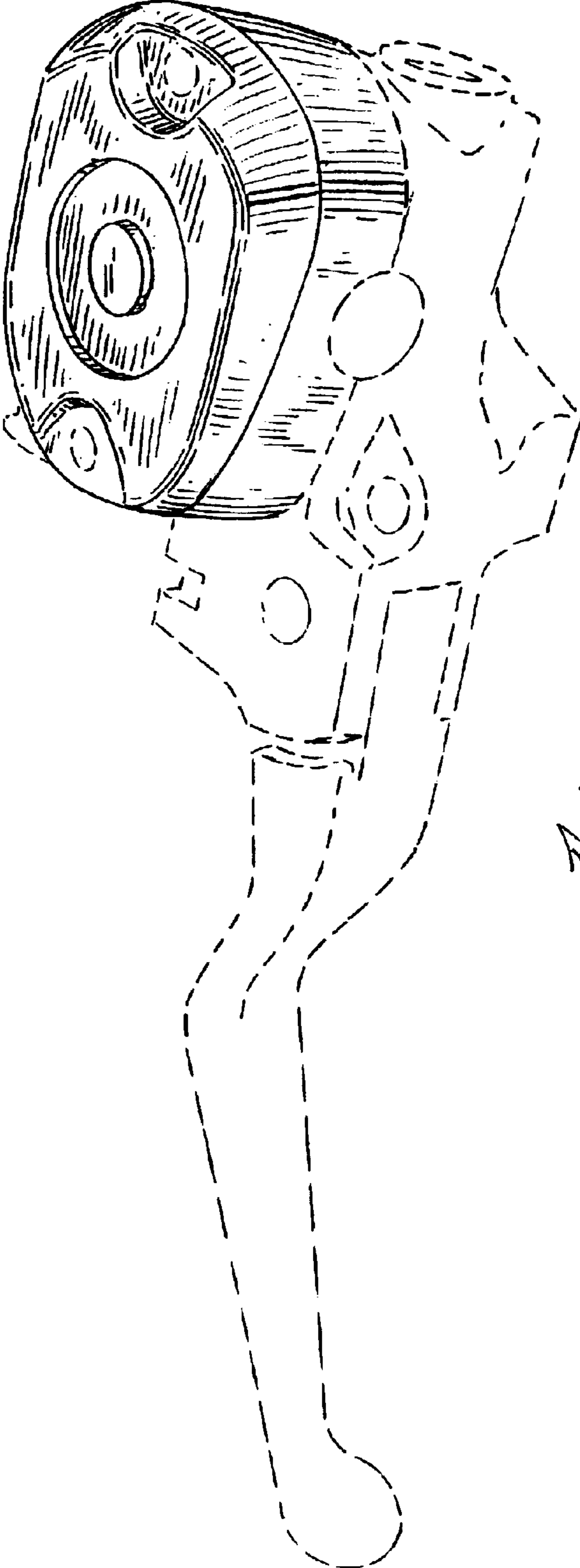
FIG. 6 is a rear view of the motorcycle master cylinder housing of FIG. 1; and,

FIG. 7 is a bottom view of the motorcycle master cylinder housing of FIG. 1.

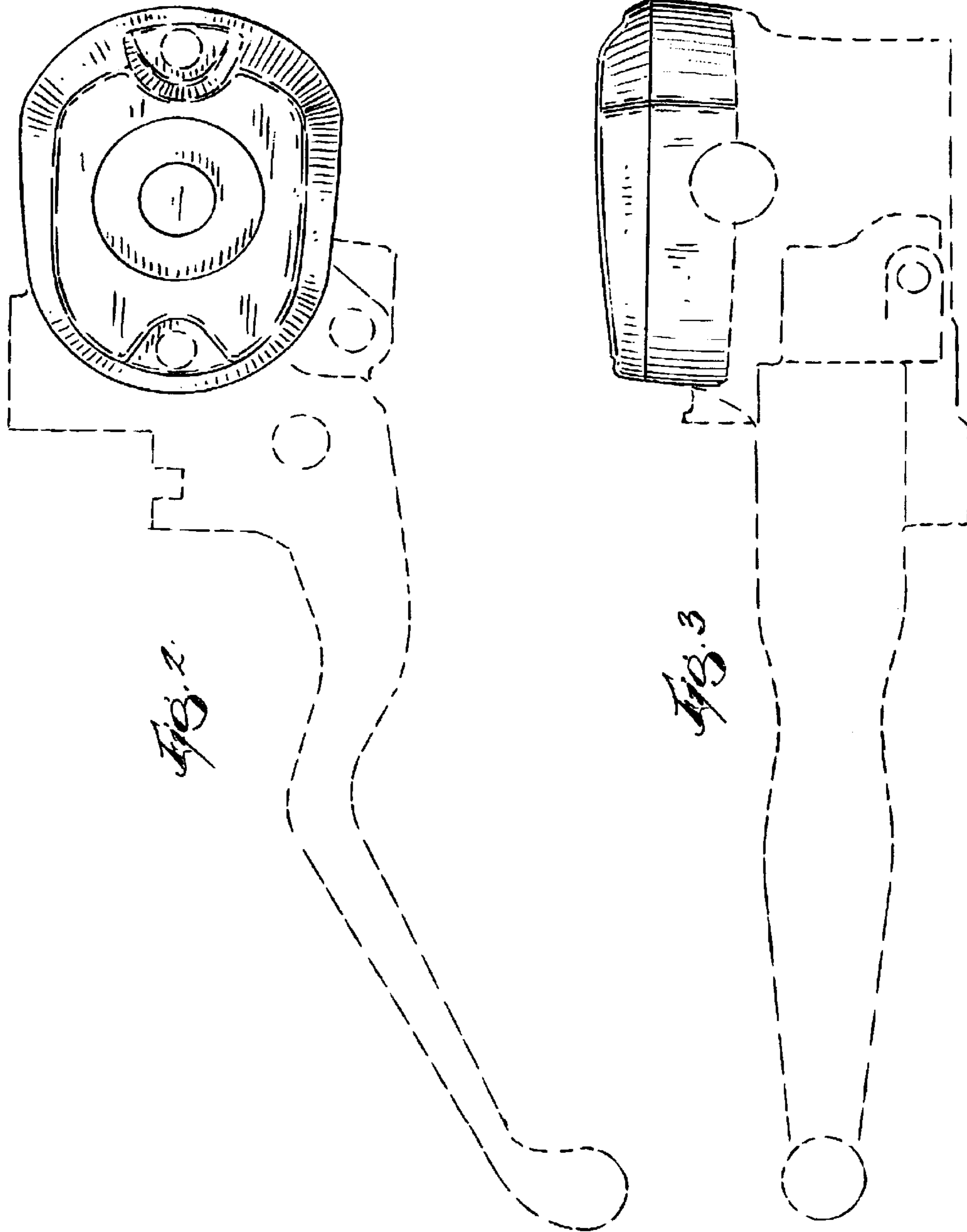
The broken line showing of the environment is for illustrative purposes only and forms no part of the claimed design. Also, the broken lines which define the boundaries of the motorcycle master cylinder housing form no part of the claimed design.

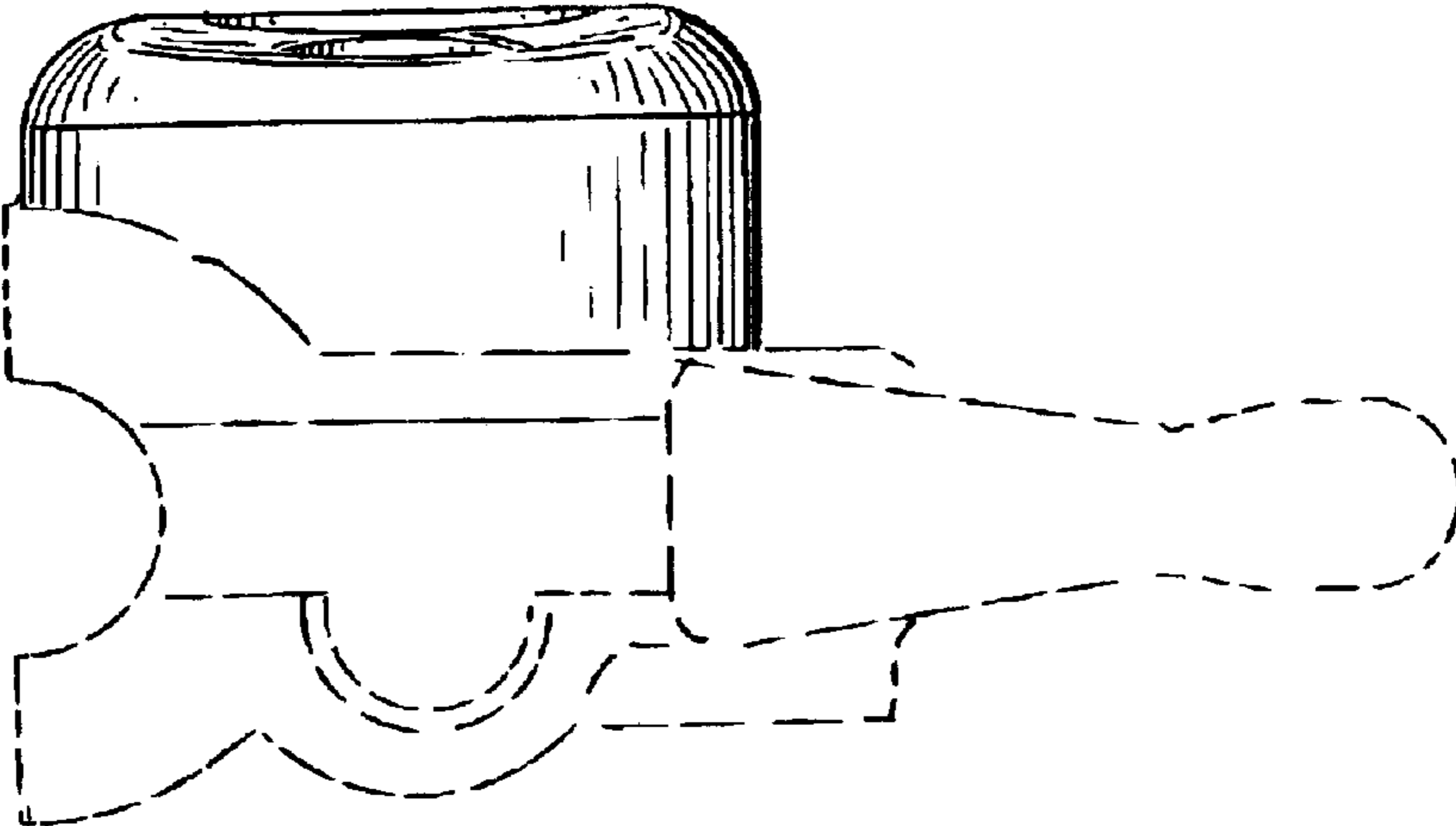
**1 Claim, 5 Drawing Sheets**



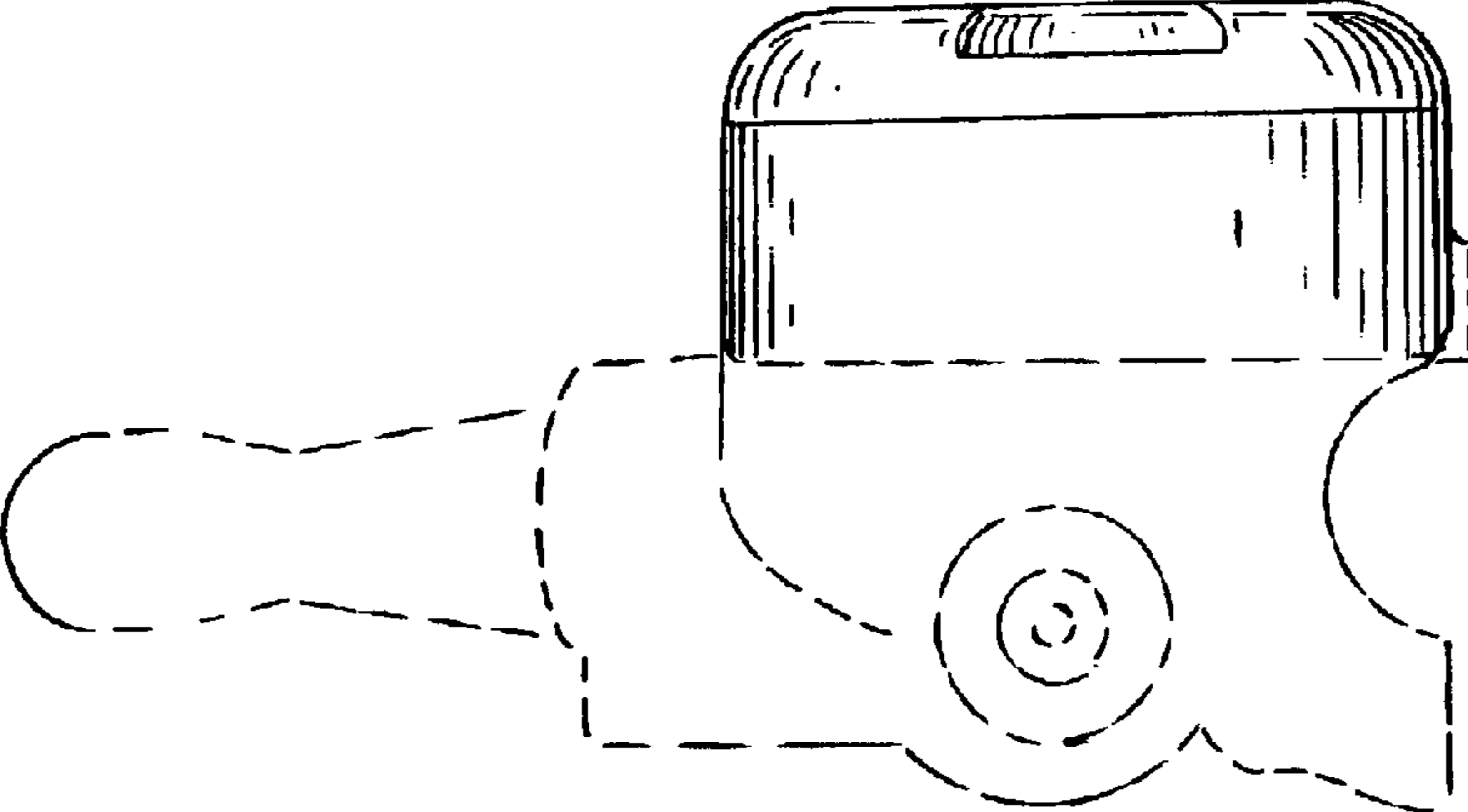


T.B.

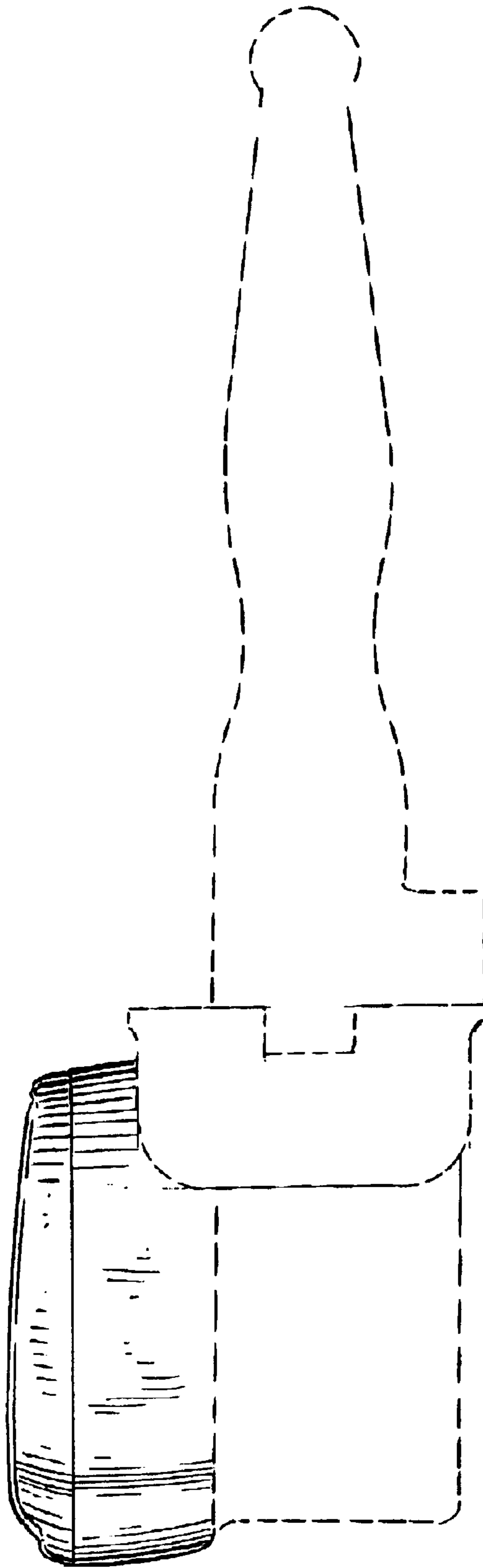




*Fig. 4*



*Fig. 5*



*Fig. 6*

