

US00D492055S1

(12) **United States Design Patent**  
**Hon et al.**

(10) **Patent No.: US D492,055 S**  
(45) **Date of Patent: \*\* Jun. 22, 2004**

(54) **SOLAR POWERED OUTDOOR LIGHT**

(75) Inventors: **Siu Cheong Hon**, Tseung Kwan O (HK); **Gary Mazurek**, Plano, TX (US)

(73) Assignee: **The Brinkmann Corporation**, Dallas, TX (US)

(\*\*) Term: **14 Years**

(21) Appl. No.: **29/192,534**

(22) Filed: **Oct. 24, 2003**

**Related U.S. Application Data**

(63) Continuation of application No. 29/176,291, filed on Feb. 19, 2003.

(51) **LOC (7) Cl.** ..... **26-05**

(52) **U.S. Cl.** ..... **D26/67**

(58) **Field of Search** ..... D26/67, 68, 72, D26/80-92; 362/147, 153, 153.1, 159, 363, 367, 368, 404-408, 431, 432

(56) **References Cited**

**U.S. PATENT DOCUMENTS**

4,293,898 A	10/1981	Budnovitch et al. ....	362/291
4,774,648 A	9/1988	Kakuk et al. ....	362/302
D305,156 S	* 12/1989	Maddock .....	D26/67
D310,577 S	9/1990	Kakuk et al. ....	D26/67
4,996,636 A	2/1991	Lovett .....	362/431
D329,100 S	* 9/1992	Hall et al. ....	D26/67
6,392,541 B1	* 5/2002	Bucher et al. ....	340/541
6,494,599 B1	* 12/2002	Leen .....	362/431

**OTHER PUBLICATIONS**

Hadco Nightlife Landscape Lighting Brochure, pp. 34 and 38, date unknown.

Three pages from Hadco Nightlife Landscape Lighting Folded Brochure, date unknown.

Four pages from Noma Garden Lighting/Eclairage de jardin Brochure, date unknown.

CENS Lighting Jul. 2002; p. 82; item #BT1007 SO.\*

\* cited by examiner

*Primary Examiner*—Clare E. Heflin

(74) *Attorney, Agent, or Firm*—Sheppard, Mullin, Richter & Hampton LLP

(57) **CLAIM**

We claim the ornamental design for a solar powered outdoor light, as shown and described.

**DESCRIPTION**

FIG. 1 is a perspective view of a solar powered outdoor light showing the new design;

FIG. 2 is a front elevational view thereof;

FIG. 3 is a left side elevational view thereof, the right side elevational view being a mirror image thereof;

FIG. 4 is a rear elevational view thereof;

FIG. 5 is a top plan view thereof; and,

FIG. 6 is a bottom plan view thereof.

The dotted lines are for illustrative purposes only and form no part of the claimed design.

**1 Claim, 6 Drawing Sheets**

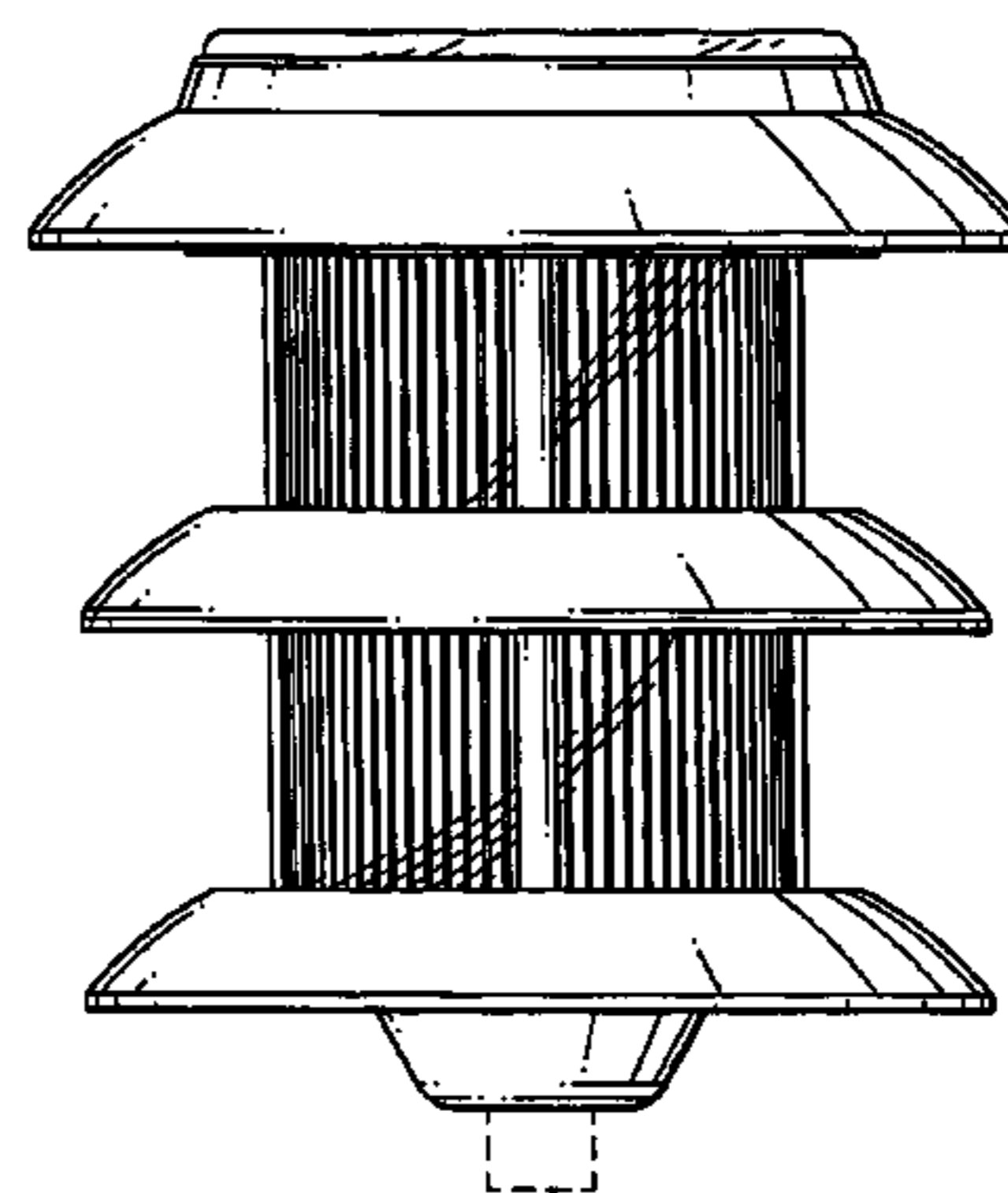
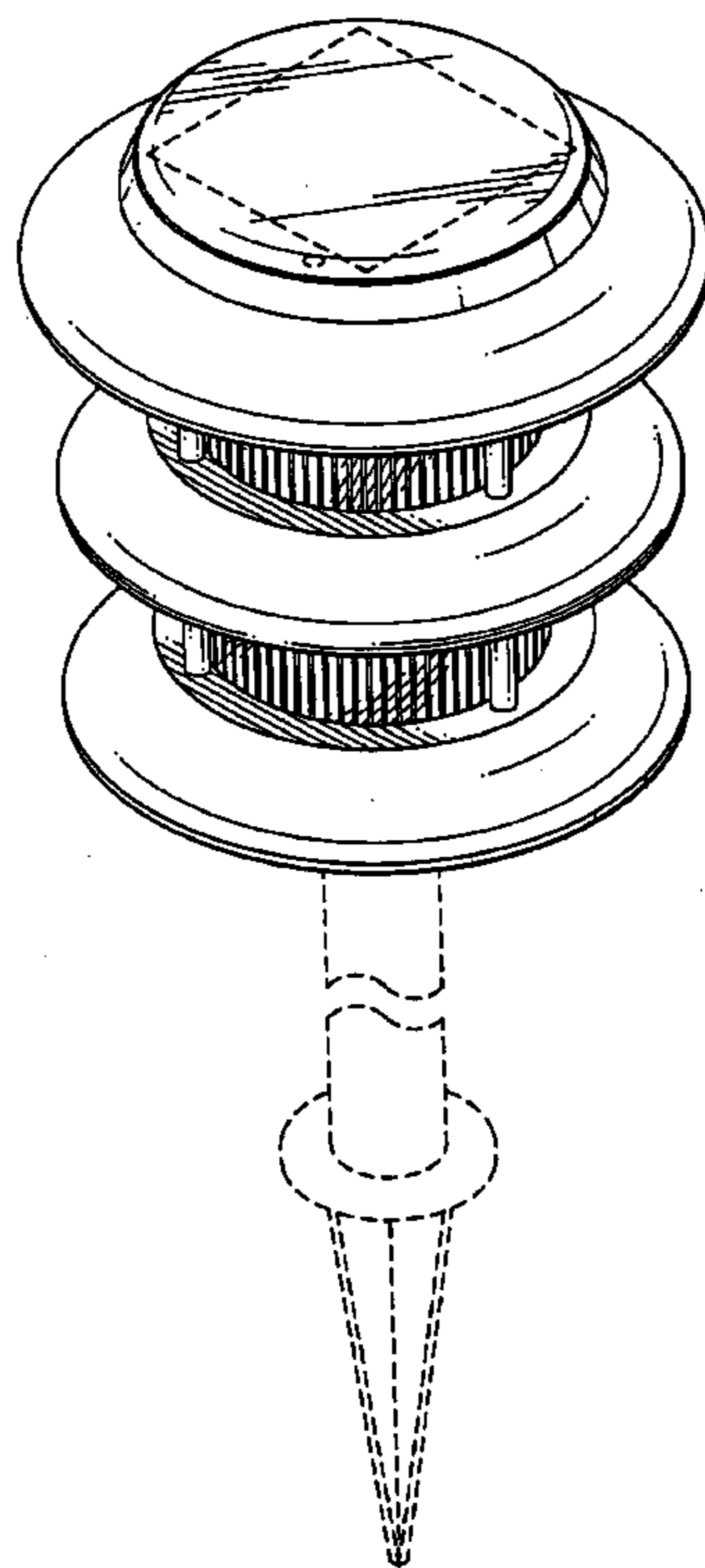

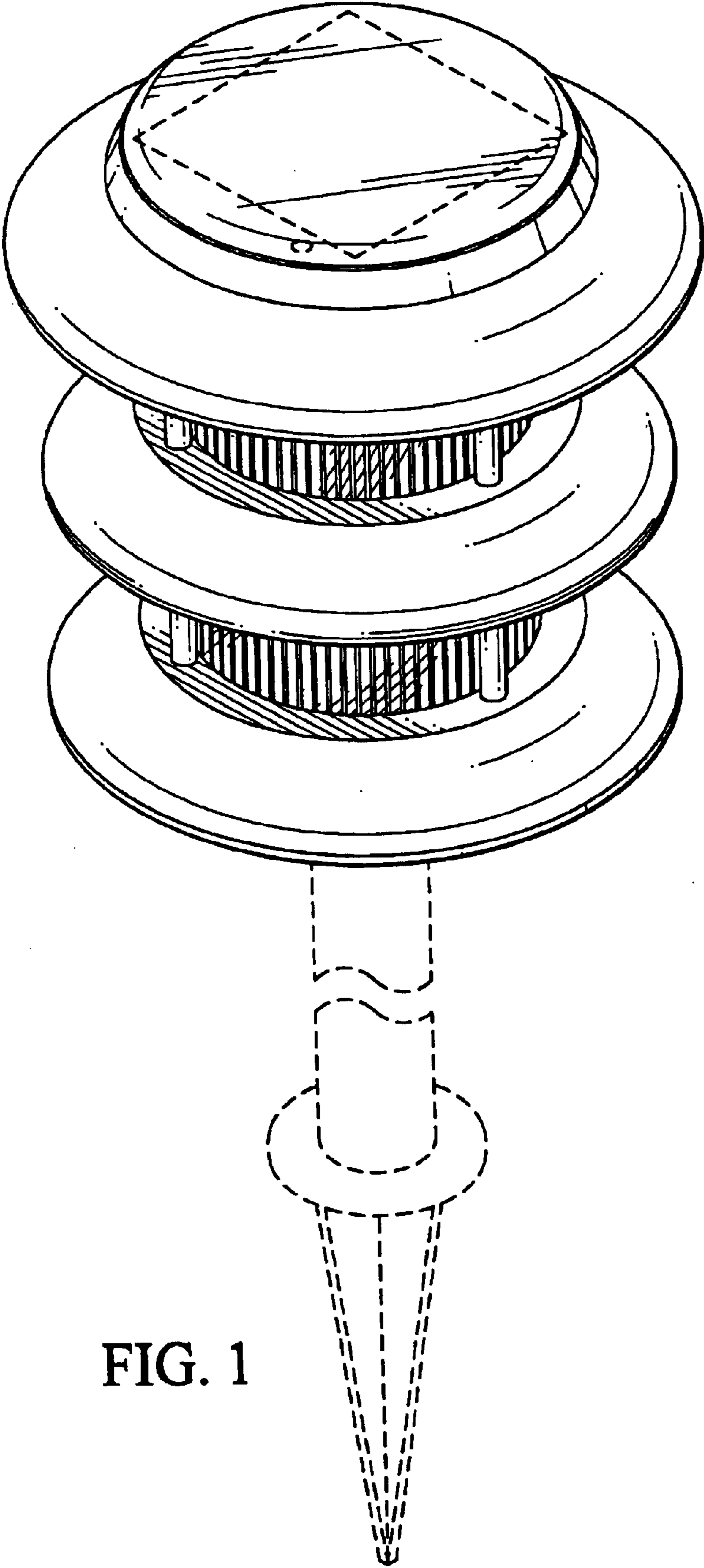

FIG. 1

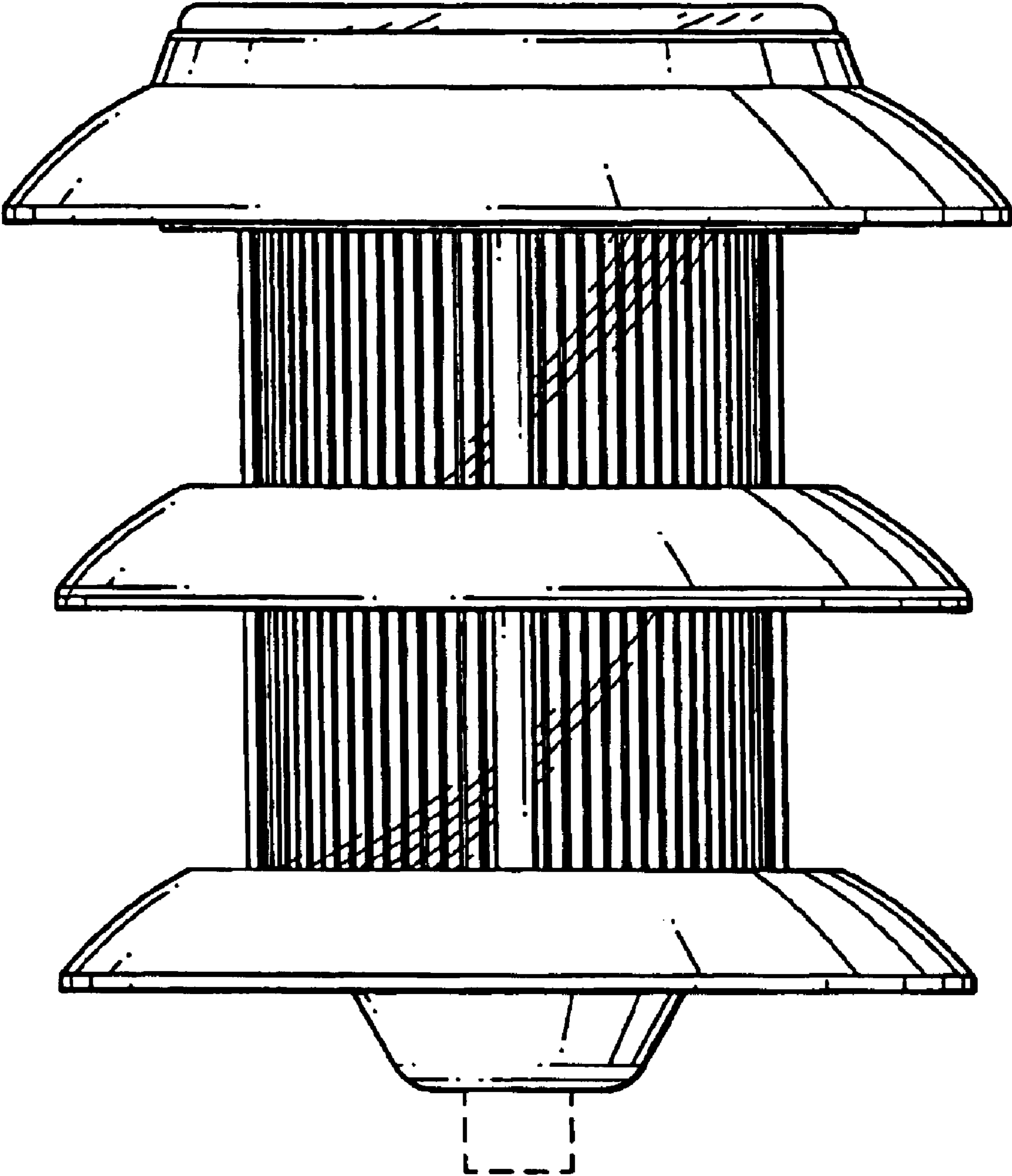

FIG. 2

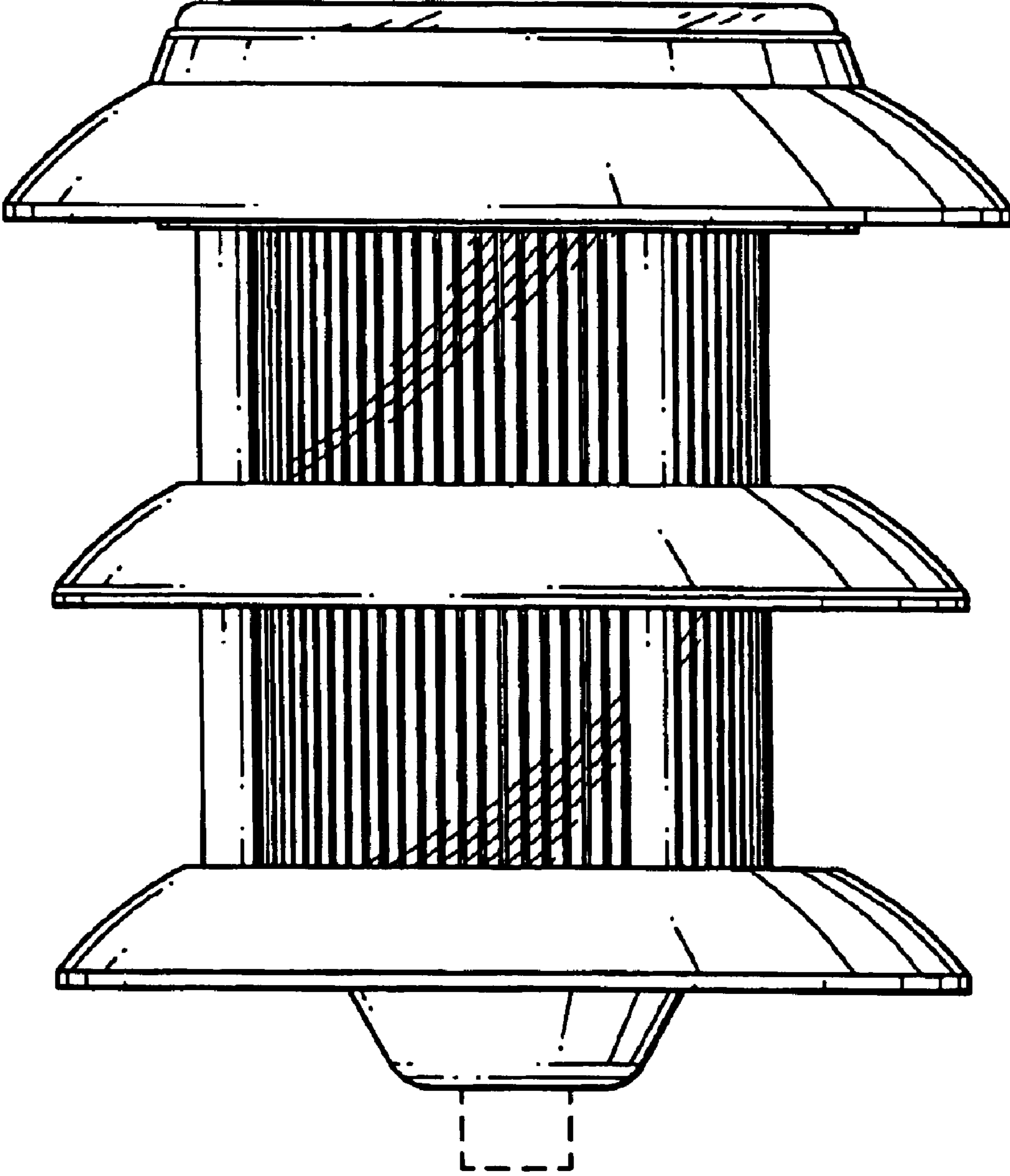

FIG. 3

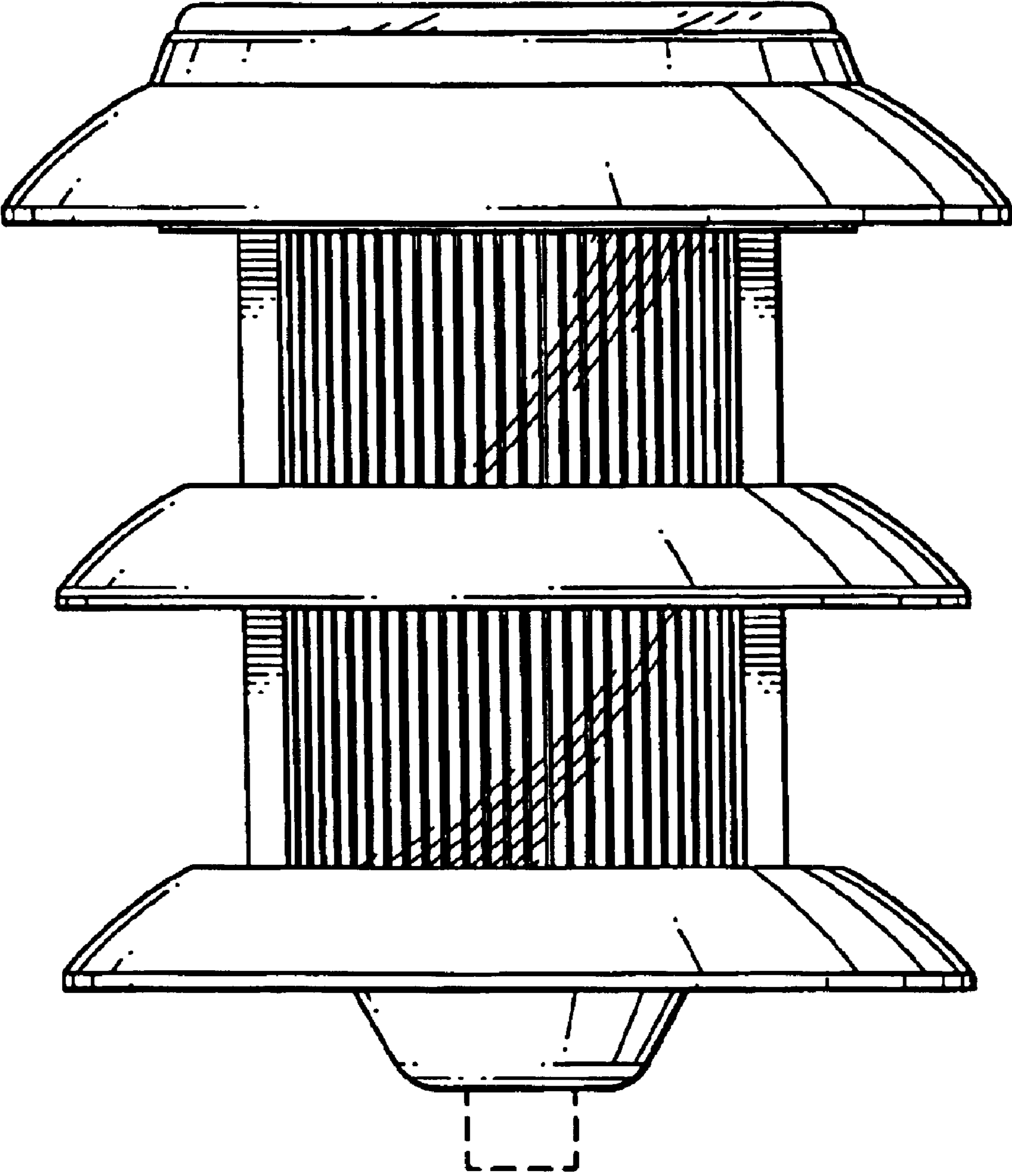

FIG. 4

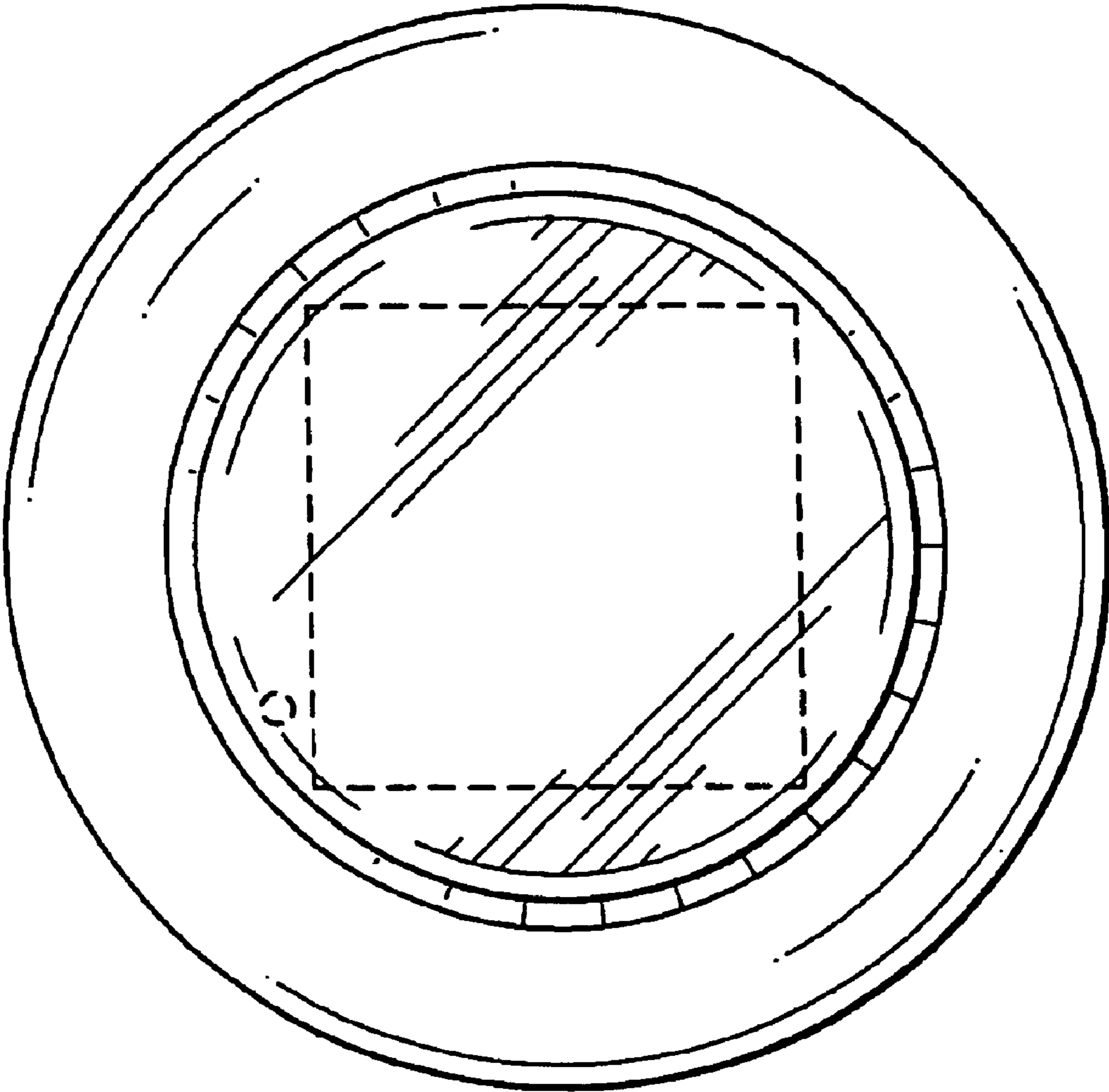

FIG. 5

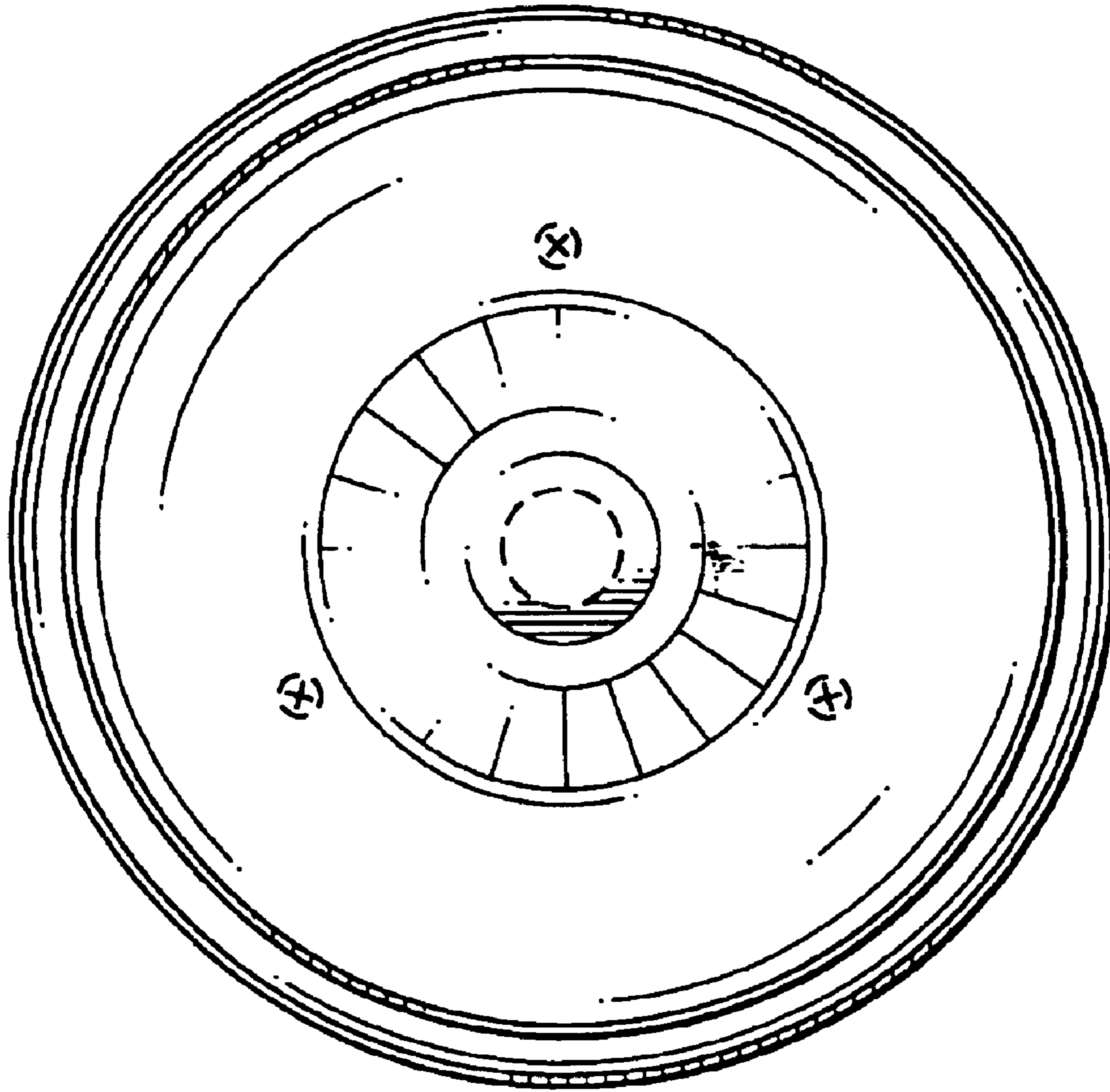

FIG. 6