

US00D492024S1

(12) **United States Design Patent**
Stout, Jr.

(10) **Patent No.: US D492,024 S**
(45) **Date of Patent: ** *Jun. 22, 2004**

(54) **REDUCER WITH AN INDENTED END**

(75) Inventor: **William K. Stout, Jr.**, Mason, OH (US)

(73) Assignee: **Eastern Sheet Metal LLC**, Cincinnati, OH (US)

(*) Notice: This patent is subject to a terminal disclaimer.

(**) Term: **14 Years**

(21) Appl. No.: **29/183,159**

(22) Filed: **Jun. 6, 2003**

Related U.S. Application Data

(62) Division of application No. 29/138,786, filed on Mar. 20, 2001, now Pat. No. Des. 480,132.

(51) **LOC (7) Cl. 23-04**

(52) **U.S. Cl. D23/393**

(58) **Field of Search** D23/259, 262, D23/263, 266, 386, 387, 391, 393, 394; 138/111-117, DIG. 4, DIG. 11, 177, 167, 169; 285/47, 123.15, 123.16, 110, 374, 347, 232-234, 123.1, 123.3-123.7, 123.9, 148.18, 148.22, 148.23, 148.24, 148.25, 179, 179.2, 181, 183, 332, 332.1, 334.5, 399, 189, 424; 454/228-236, 243, 270, 903, 906; 126/307 R, 312, 307 A, 314-317

(56) **References Cited**

U.S. PATENT DOCUMENTS

D25,709 S 6/1896 Pratt

(List continued on next page.)

FOREIGN PATENT DOCUMENTS

DE 2840962 4/1979

(List continued on next page.)

OTHER PUBLICATIONS

Ducts and Fittings Product Brochure, Lindab Ltd., Northampton, Great Britain (undated), front and back covers and pp. 3-52.

(List continued on next page.)

Primary Examiner—Philip S. Hyder

Assistant Examiner—C. Tuttle

(74) *Attorney, Agent, or Firm*—Dinsmore & Shohl LLP

(57) **CLAIM**

The ornamental design for a reducer with an indented end, as shown and described.

DESCRIPTION

FIG. 1 is a front elevational view of a first embodiment of the reducer with an indented end; the rear elevational, top and bottom views being identical to FIG. 1;

FIG. 2 is a front perspective view of the reducer of FIG. 1;

FIG. 3 is a left end view of the reducer of FIG. 1;

FIG. 4 is a right end view of the reducer of FIG. 1;

FIG. 5 is a front elevational view of a second embodiment of the reducer with an indented end; the rear elevational, top and bottom views being identical to FIG. 5;

FIG. 6 is a front perspective view of the reducer of FIG. 5;

FIG. 7 is a left end view of the reducer of FIG. 5;

FIG. 8 is a right end view of the reducer of FIG. 5;

FIG. 9 is a front elevational view of a third embodiment of the reducer with an indented end; the rear elevational view being a mirror image of FIG. 9;

FIG. 10 is a front perspective view of the reducer of FIG. 9;

FIG. 11 is a left end view of the reducer of FIG. 9;

FIG. 12 is a right end view of the reducer of FIG. 9;

FIG. 13 is a top view of the reducer of FIG. 9;

FIG. 14 is a bottom view of the reducer of FIG. 9;

FIG. 15 is a front elevational view of a fourth embodiment of the reducer with an indented end; the rear elevational view being a mirror image of FIG. 15;

FIG. 16 is a front perspective view of the reducer of FIG. 15;

FIG. 17 is a left end view of the reducer of FIG. 15;

FIG. 18 is a right end view of the reducer of FIG. 15;

FIG. 19 is top view of the reducer of FIG. 15; and,

FIG. 20 is a bottom view of the reducer of FIG. 15.

The broken lines shown in the figures are for illustrative purposes only and form no part of the claimed design. The unshaded areas of the interior and midsections of the reducer likewise form no part of the claimed design.

1 Claim, 16 Drawing Sheets

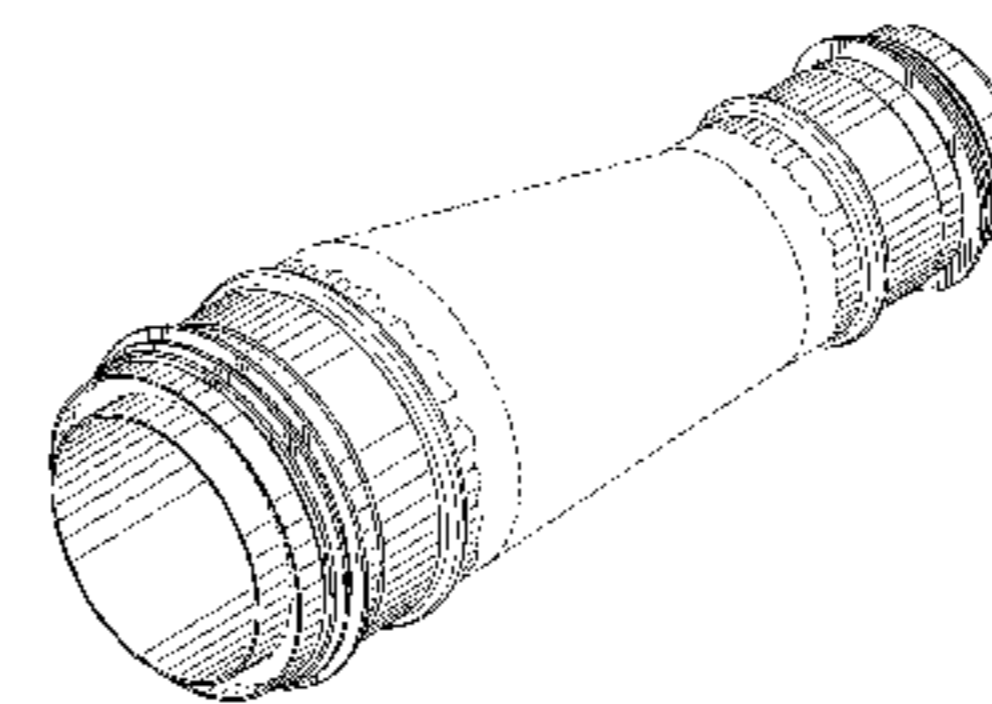
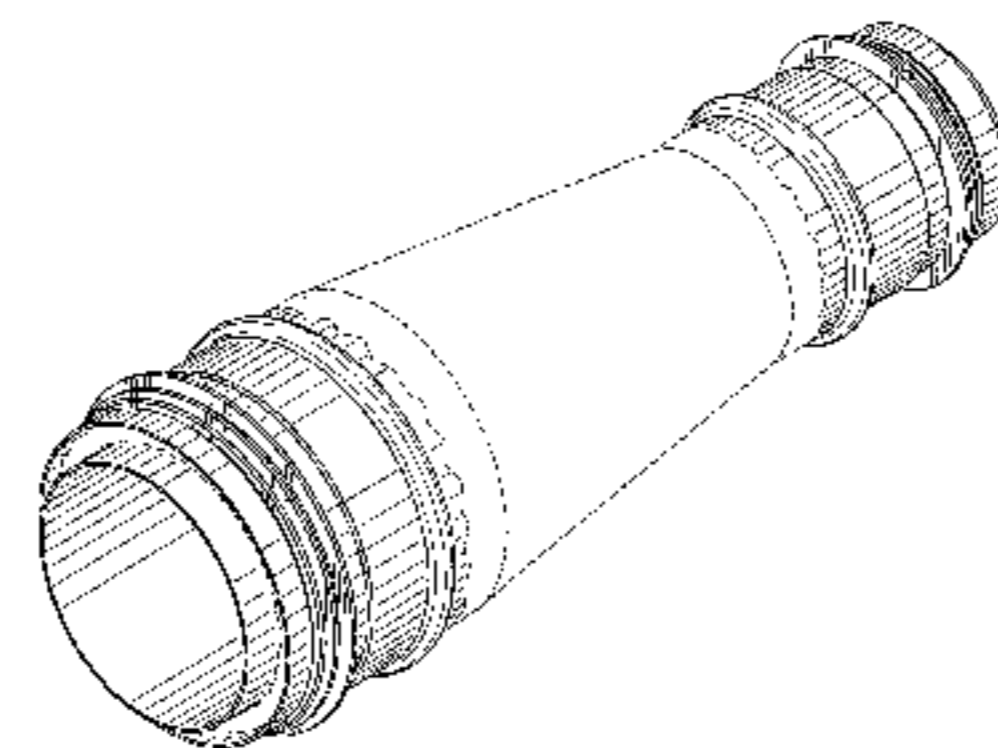
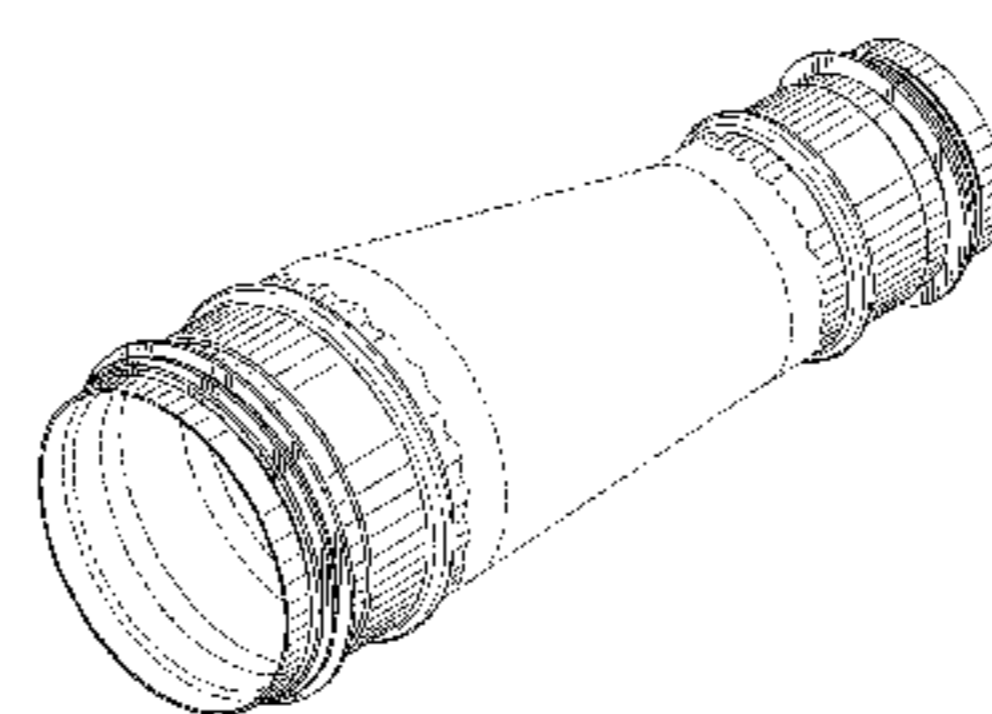
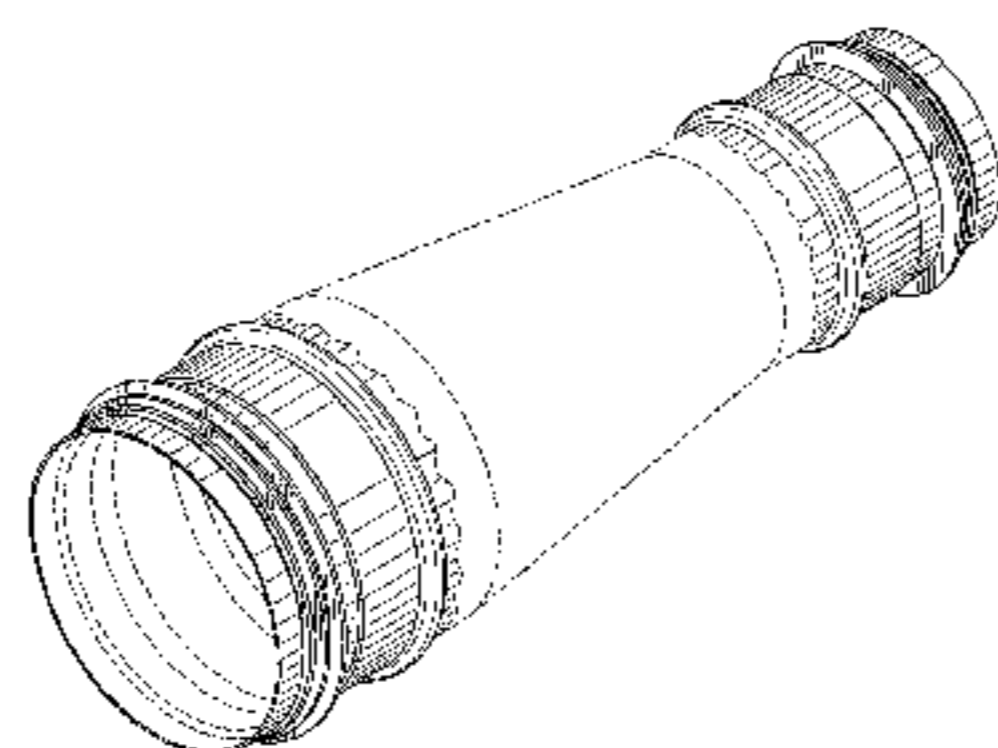

US D492,024 S

Page 2

U.S. PATENT DOCUMENTS

1,301,096 A 4/1919 Brockest
1,565,918 A 12/1925 Fitzgerald
1,570,974 A 1/1926 Stevens
2,039,542 A 5/1936 Lindquist
2,314,386 A 3/1943 Brend
2,544,108 A 3/1951 Richardson
2,616,728 A 11/1952 Pitt
2,746,114 A 5/1956 Williams
2,930,635 A 3/1960 Woodling
3,015,510 A 1/1962 Bates
D234,847 S 4/1975 Hoffman
3,955,834 A 5/1976 Ahlrot
4,007,941 A 2/1977 Stancati
4,050,703 A 9/1977 Tuvevsson et al.
4,193,246 A 3/1980 Schiefer et al.
4,418,943 A 12/1983 Ionna
D273,702 S 5/1984 Widerby et al.
4,583,772 A 4/1986 Vassallo et al.
4,664,421 A 5/1987 Jones
4,941,693 A 7/1990 Spaude et al.
5,390,961 A 2/1995 Guthrie
5,405,174 A 4/1995 Sondén et al.
5,407,122 A 4/1995 Stefansson et al.
D360,018 S 7/1995 Sondén et al.
D360,019 S 7/1995 Sonden et al.
D360,020 S 7/1995 Sondén et al.
D360,021 S 7/1995 Sondén et al.
D361,829 S 8/1995 Sondén et al.
D362,299 S 9/1995 Sondén et al.
D362,300 S 9/1995 Sondén et al.
5,452,922 A 9/1995 Ziu
D363,115 S 10/1995 Lennartsson
5,473,815 A 12/1995 Sonden et al.
D367,316 S 2/1996 Sonden et al.
D368,304 S 3/1996 Morrison
5,531,460 A 7/1996 Stefansson et al.
D377,829 S 2/1997 Andresen
5,599,600 A 2/1997 Rau
5,649,662 A 7/1997 Krichau et al.
D383,053 S 9/1997 Schrader et al.
D383,195 S 9/1997 Sondén et al.
D383,196 S 9/1997 Sondén et al.
D386,246 S 11/1997 Sondén et al.
D402,354 S 12/1998 Strong et al.
D407,802 S 4/1999 Hatfield et al.
D427,667 S 7/2000 Stout, Jr.
D427,668 S 7/2000 Stout, Jr.
D427,673 S 7/2000 Stout, Jr.
D430,482 S 9/2000 Stout, Jr.
D435,090 S 12/2000 Stout, Jr.
D437,034 S 1/2001 Stout, Jr.
6,170,883 B1 1/2001 Mattsson et al.
6,220,303 B1 4/2001 Secher et al.
D447,223 S 8/2001 Mattsson et al.
D454,949 S 3/2002 Mattsson et al.
D456,071 S 4/2002 Mattsson et al.

D456,072 S 4/2002 Mattsson et al.
D461,887 S 8/2002 Mattsson et al.
6,431,609 B1 8/2002 Andersson

FOREIGN PATENT DOCUMENTS

DK 150025 B 11/1986
EP 092881 A2 11/1983
EP 0273221 B1 7/1988
EP 0389462 A1 9/1990
EP 07580066 B1 2/1997
FR 2015241 4/1970
GB 1587018 3/1981
IT 1285015 3/1998
NO 174861 4/1994
SE 13987 1/1974
SE 17788 4/1976
SE 19819 4/1977
SE 25473 4/1980
SE 25610 4/1980
SE 26059 7/1980
SE 26995 12/1980
WO WO 9415133 7/1994

OTHER PUBLICATIONS

“Sistema Di Tenuta Ring”, Issued by Climovent System, an Italian Company; pp. 1–6 (Undated).
“Veloduct” catalog 1997, ABB Ventilation Products AB, Division Veloduct.
Hallstroms Verkstader 2 page advertisement and an English translation of portions thereof. Mar. 21, 2000.
U.S. patent application Ser. No. 29/138,761.
U.S. patent application Ser. No. 29/138,838.
U.S. patent application Ser. No. 29/138,820.
U.S. patent application Ser. No. 29/138,847.
U.S. patent application Ser. No. 29/138,785.
U.S. patent application Ser. No. 29/138,839.
U.S. patent application Ser. No. 29/138,830.
U.S. patent application Ser. No. 29/138,818.
U.S. patent application Ser. No. 29/138,819.
U.S. patent application Ser. No. 29/138,782.
U.S. patent application Ser. No. 29/138,790.
U.S. patent application Ser. No. 29/138,783.
U.S. patent application Ser. No. 29/138,771.
U.S. patent application Ser. No. 29/138,760.
U.S. patent application Ser. No. 29/138,836.
U.S. patent application Ser. No. 29/138,764.
U.S. patent application Ser. No. 29/138,668.
U.S. patent application Ser. No. 29/138,772.
U.S. patent application Ser. No. 29/138,784.
U.S. patent application Ser. No. 29/138,781.
U.S. patent application Ser. No. 29/138,842.
U.S. patent application Ser. No. 29/138,837.
U.S. patent application Ser. No. 29/138,763.
U.S. patent application Ser. No. 29/138,829.
U.S. patent application Ser. No. 29/138,762.

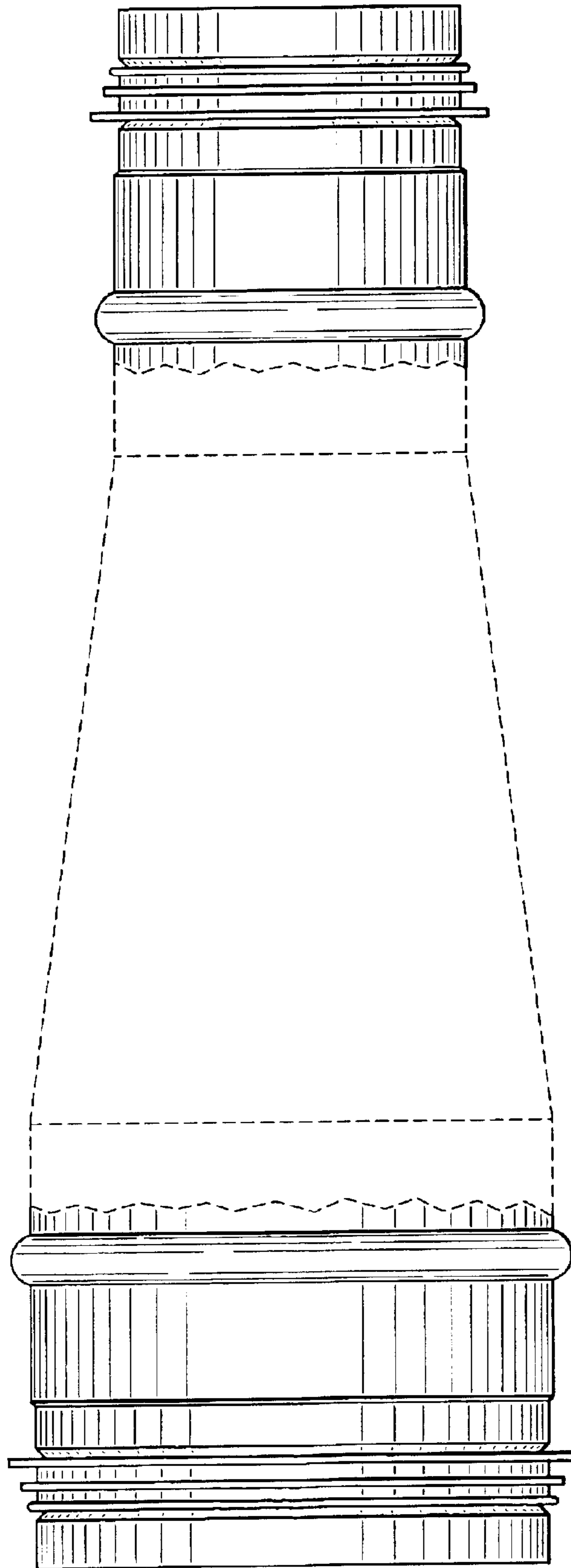

FIG. 1

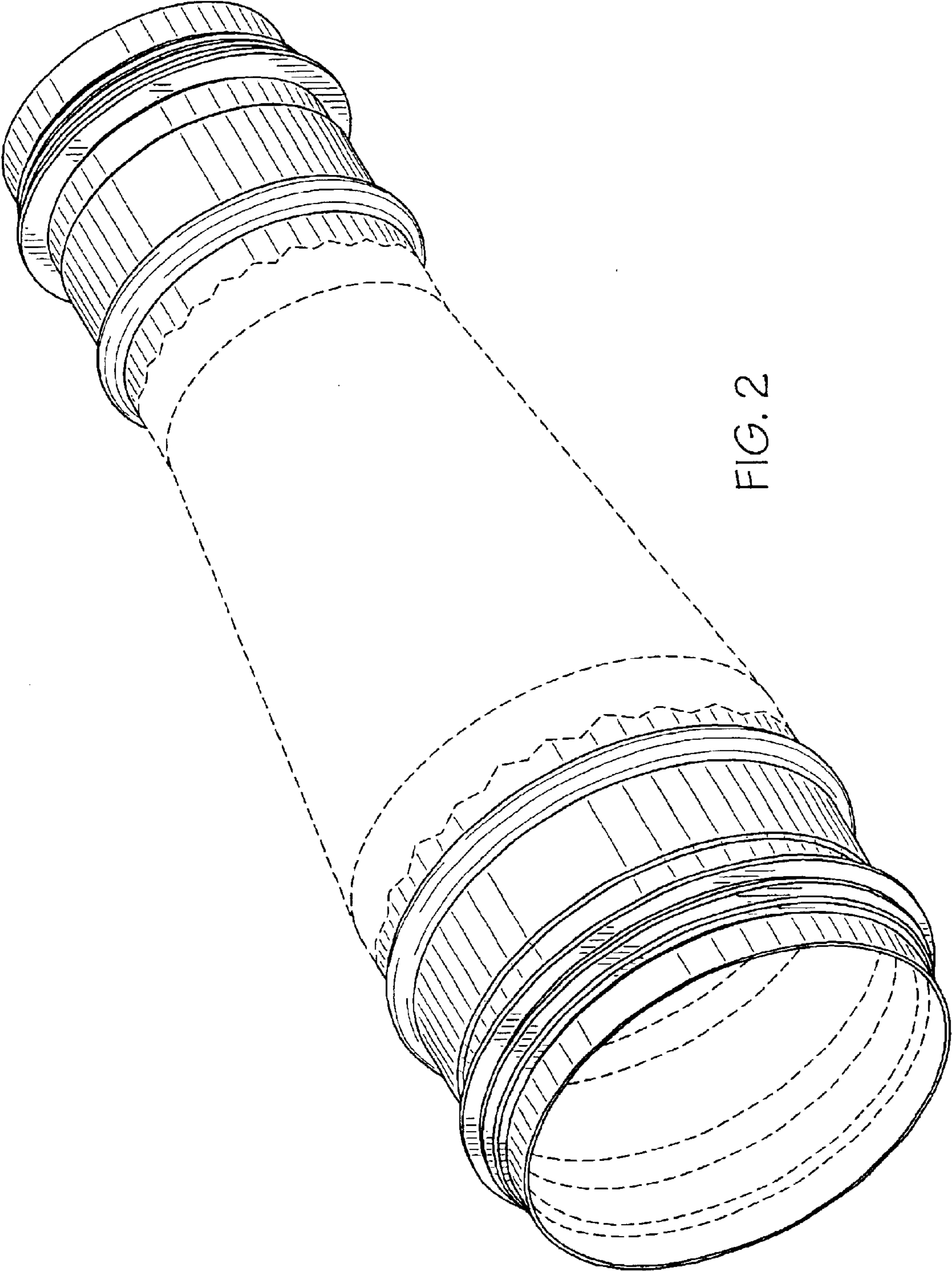

FIG. 2

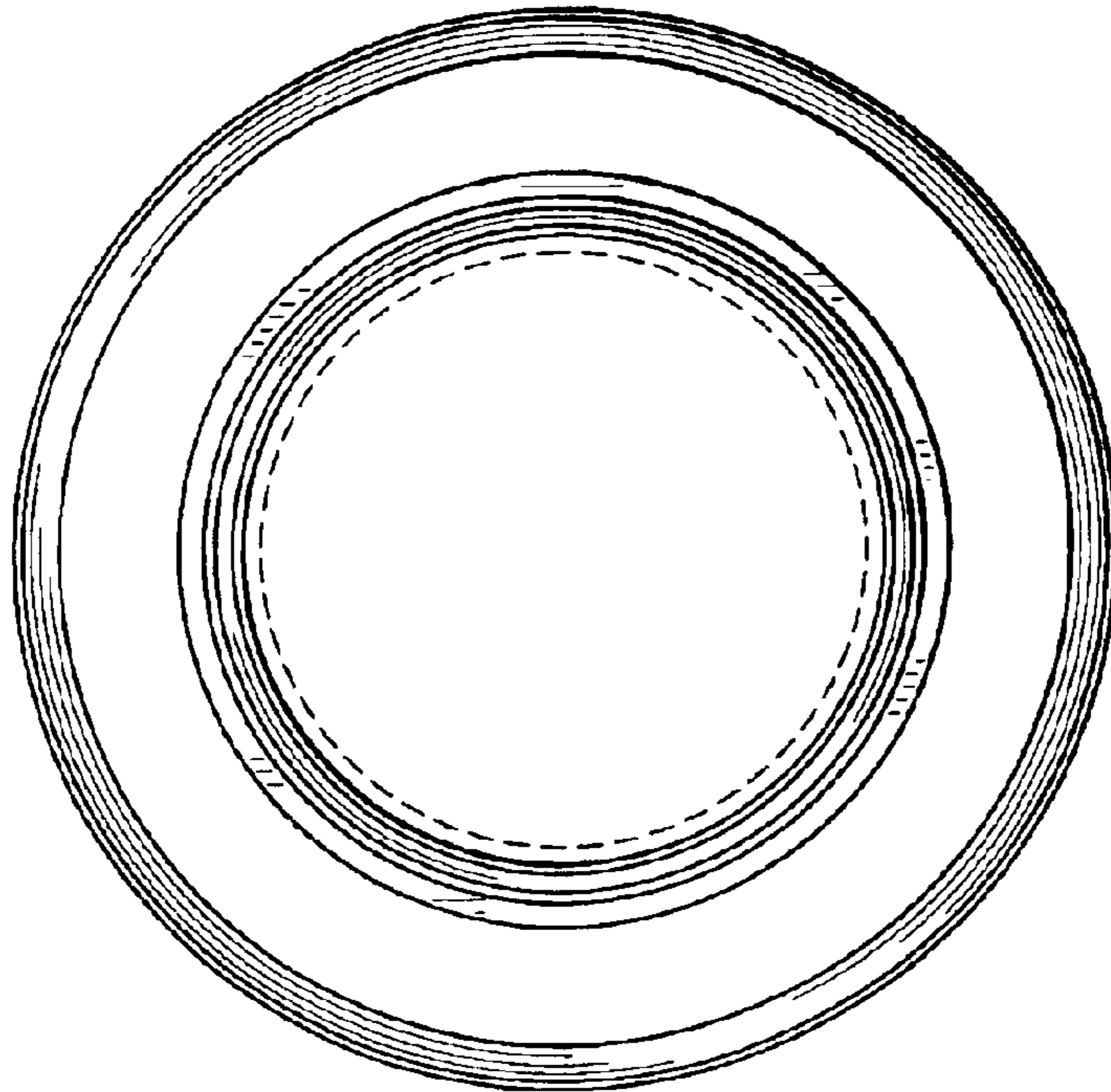

FIG. 4

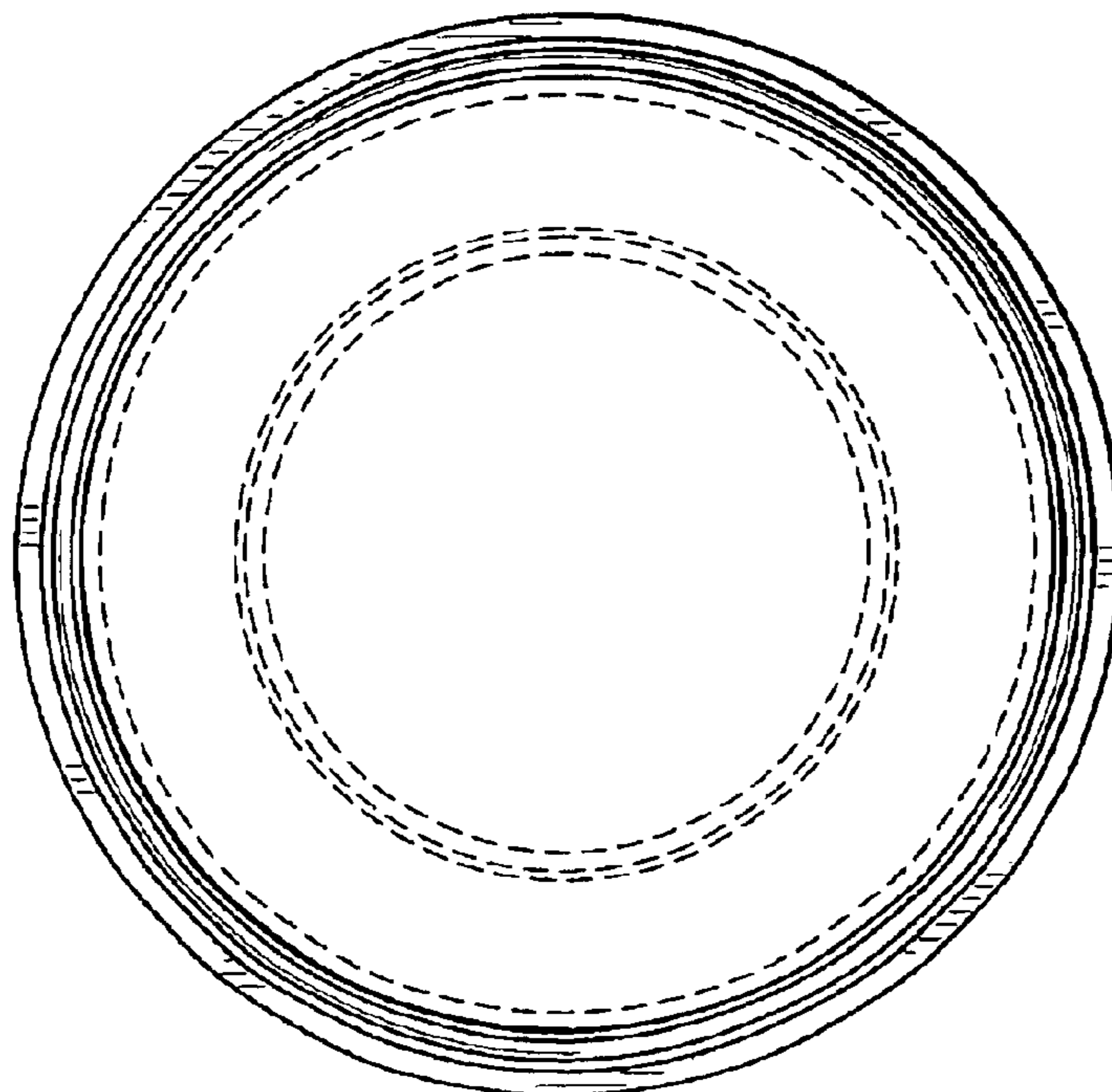

FIG. 3

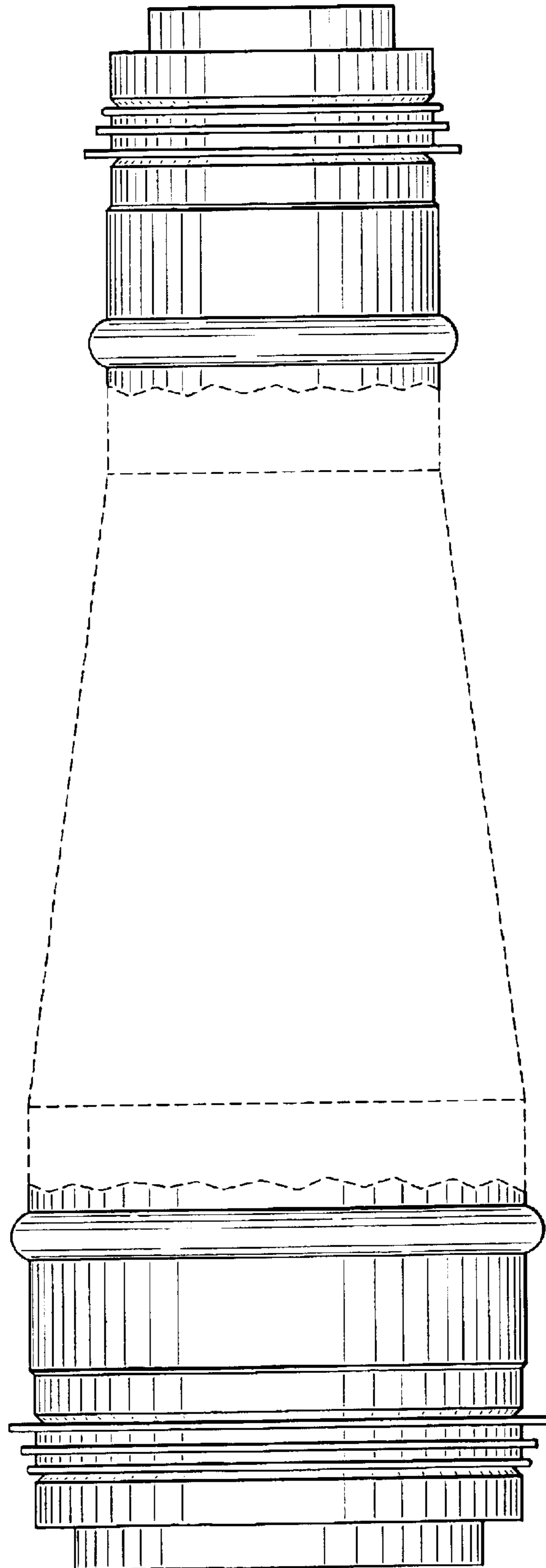

FIG. 5

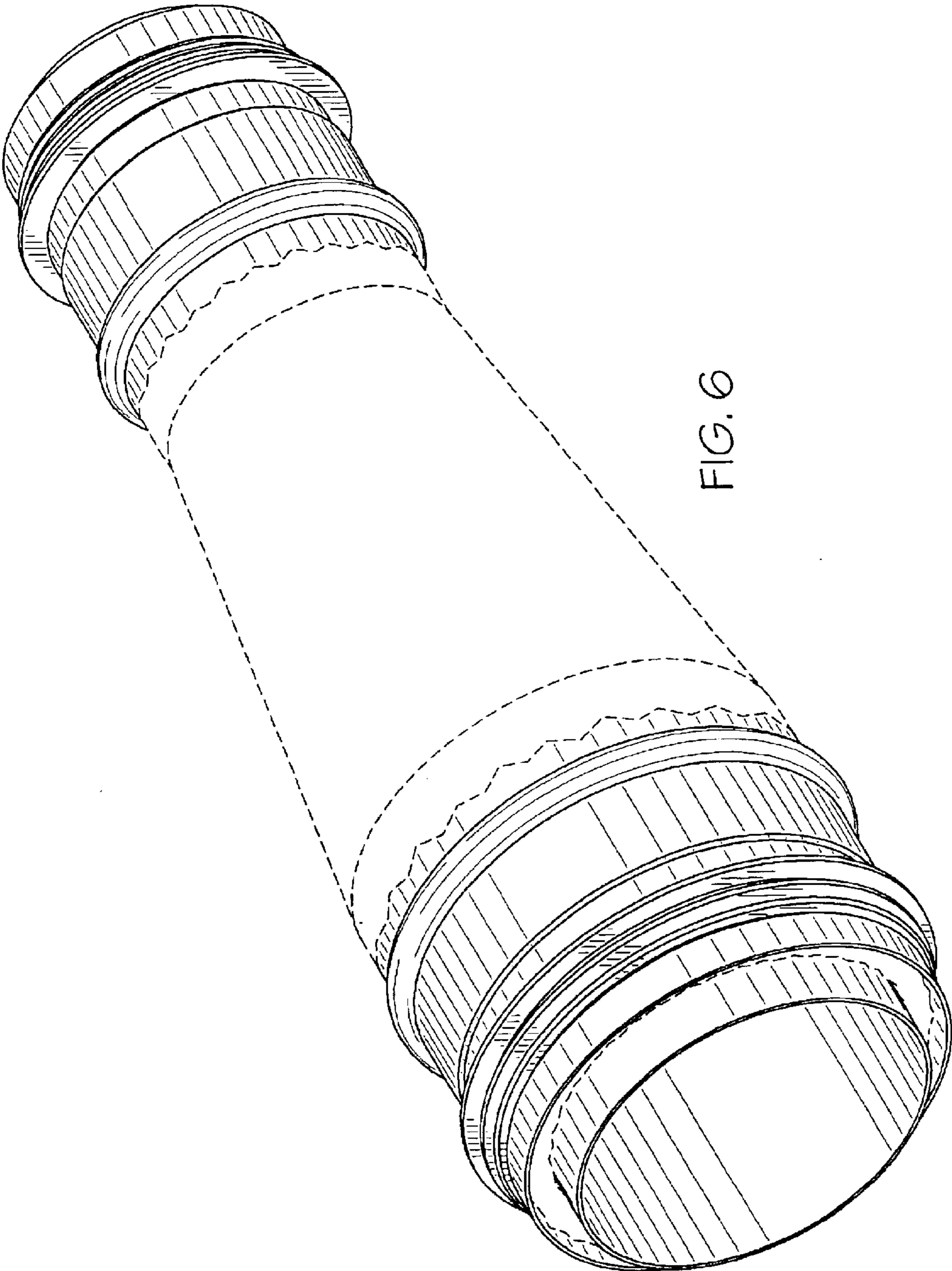

FIG. 6

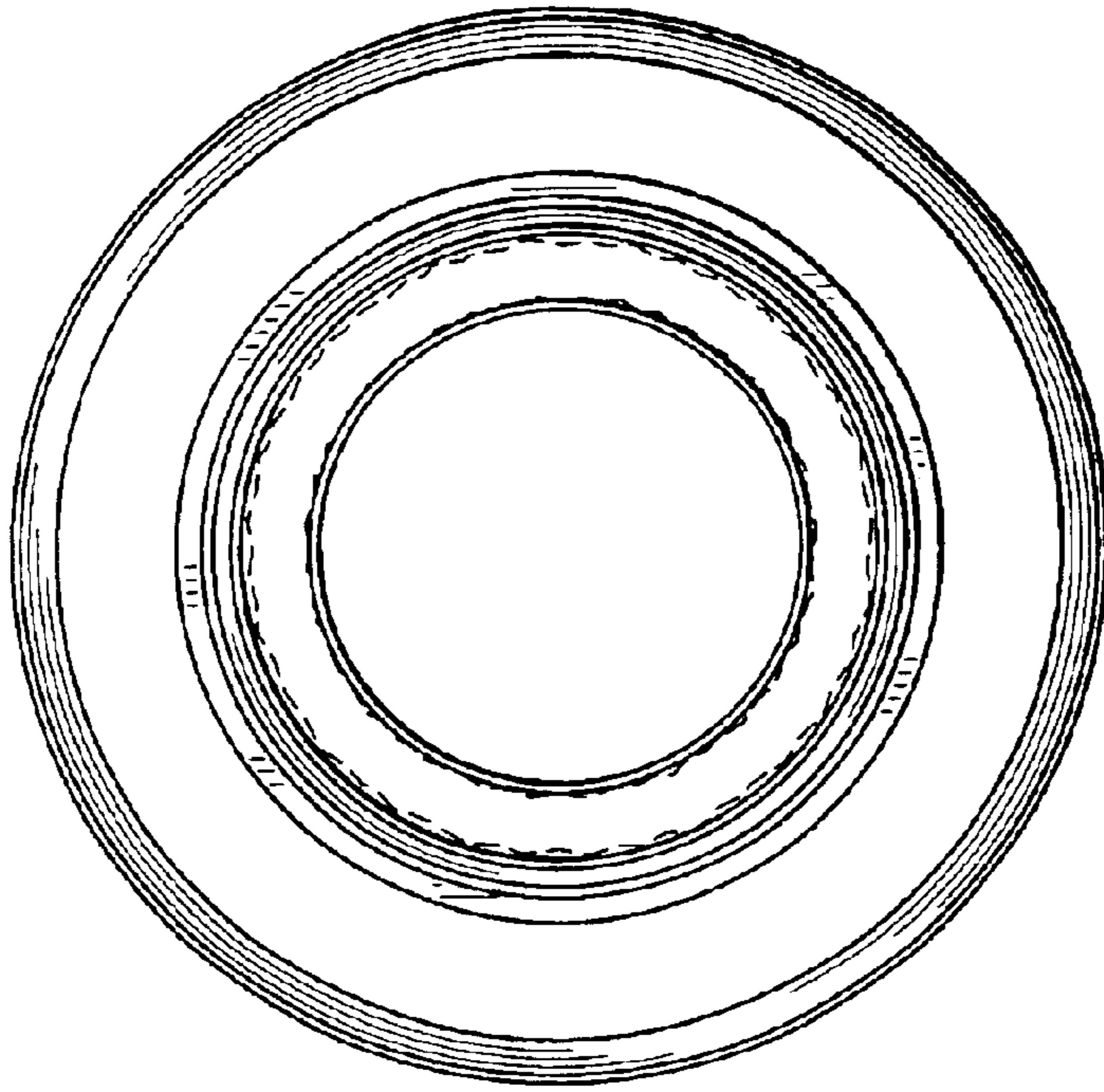

FIG. 8

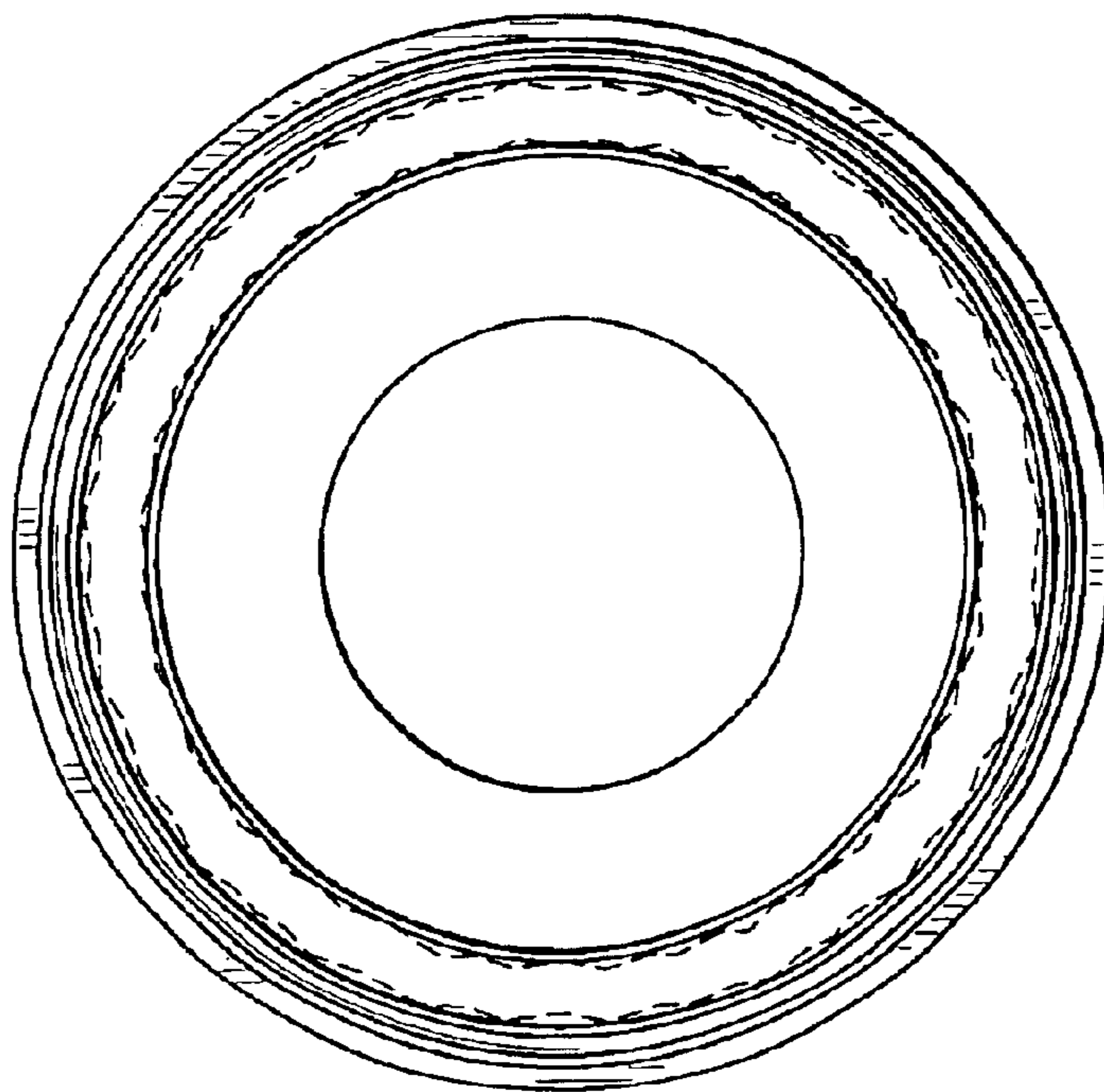

FIG. 7

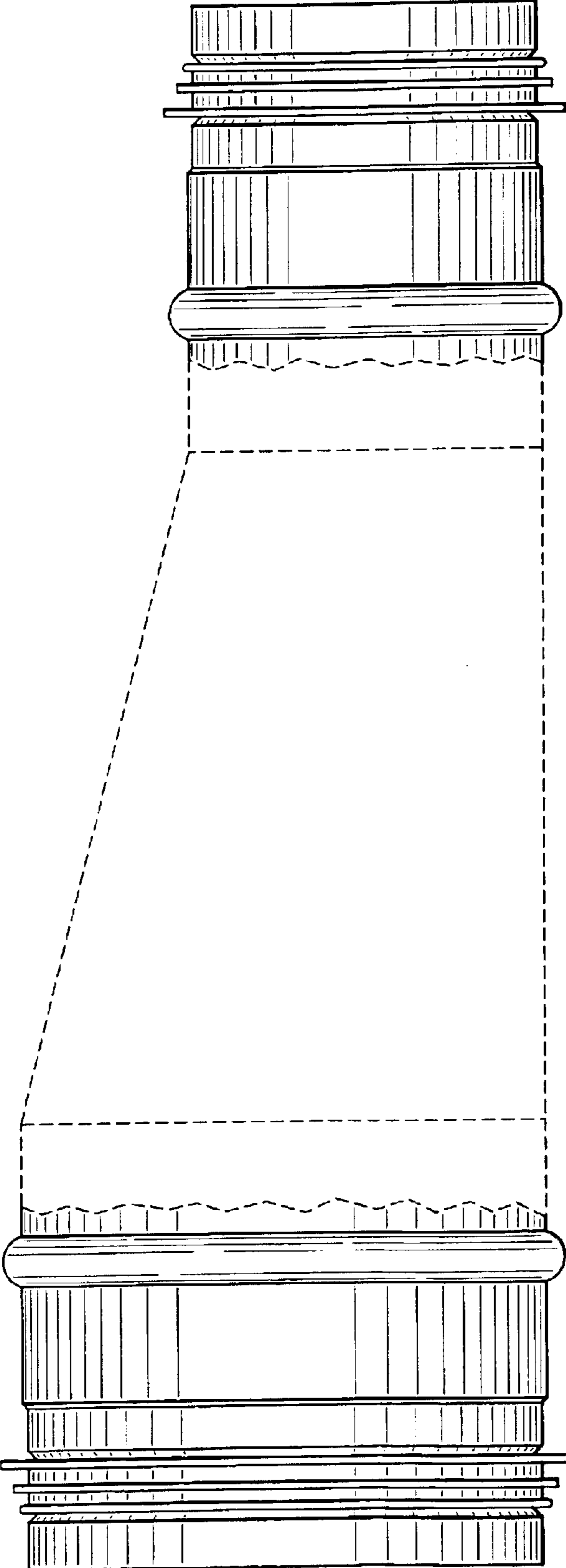

FIG. 9

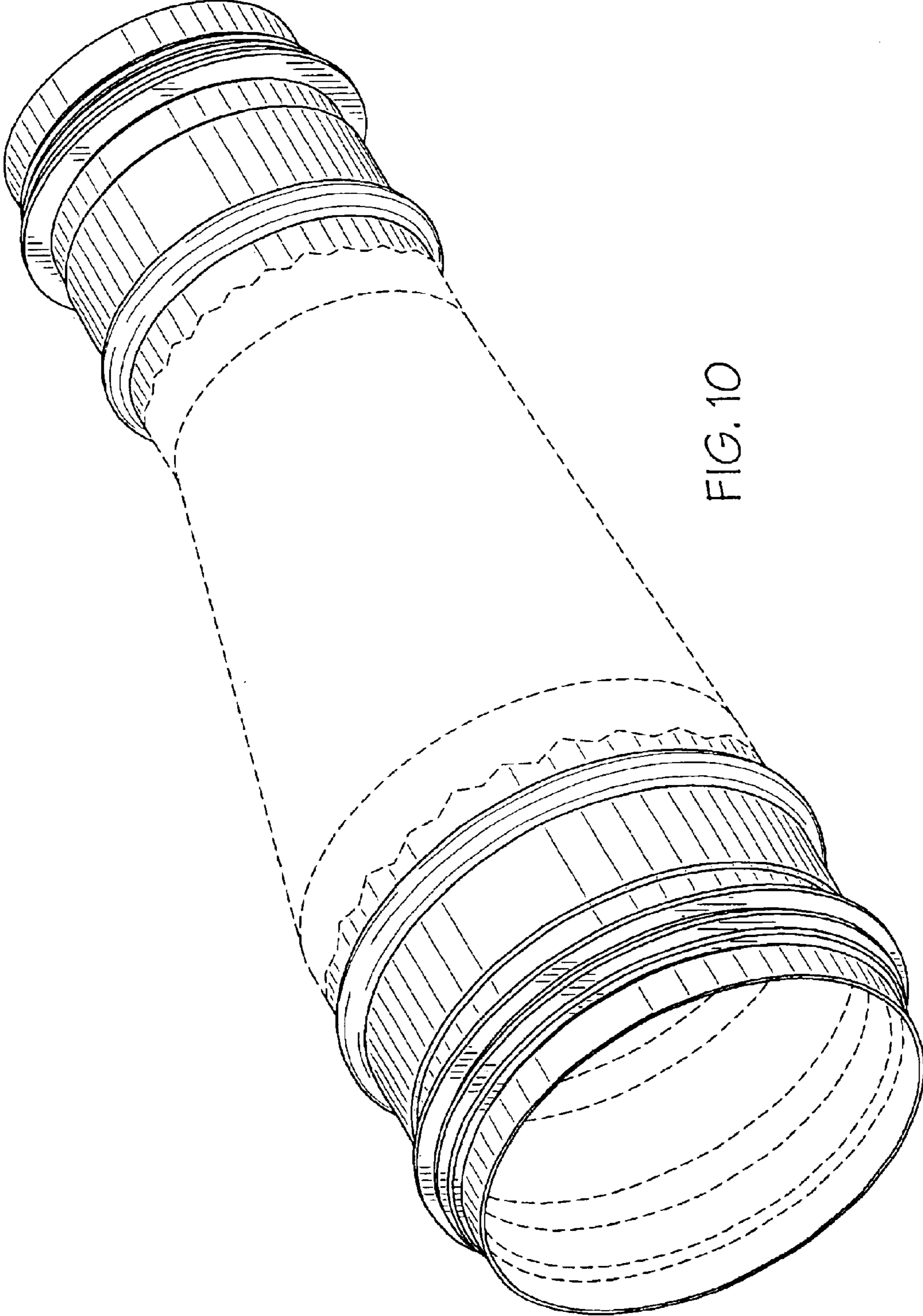

FIG. 10

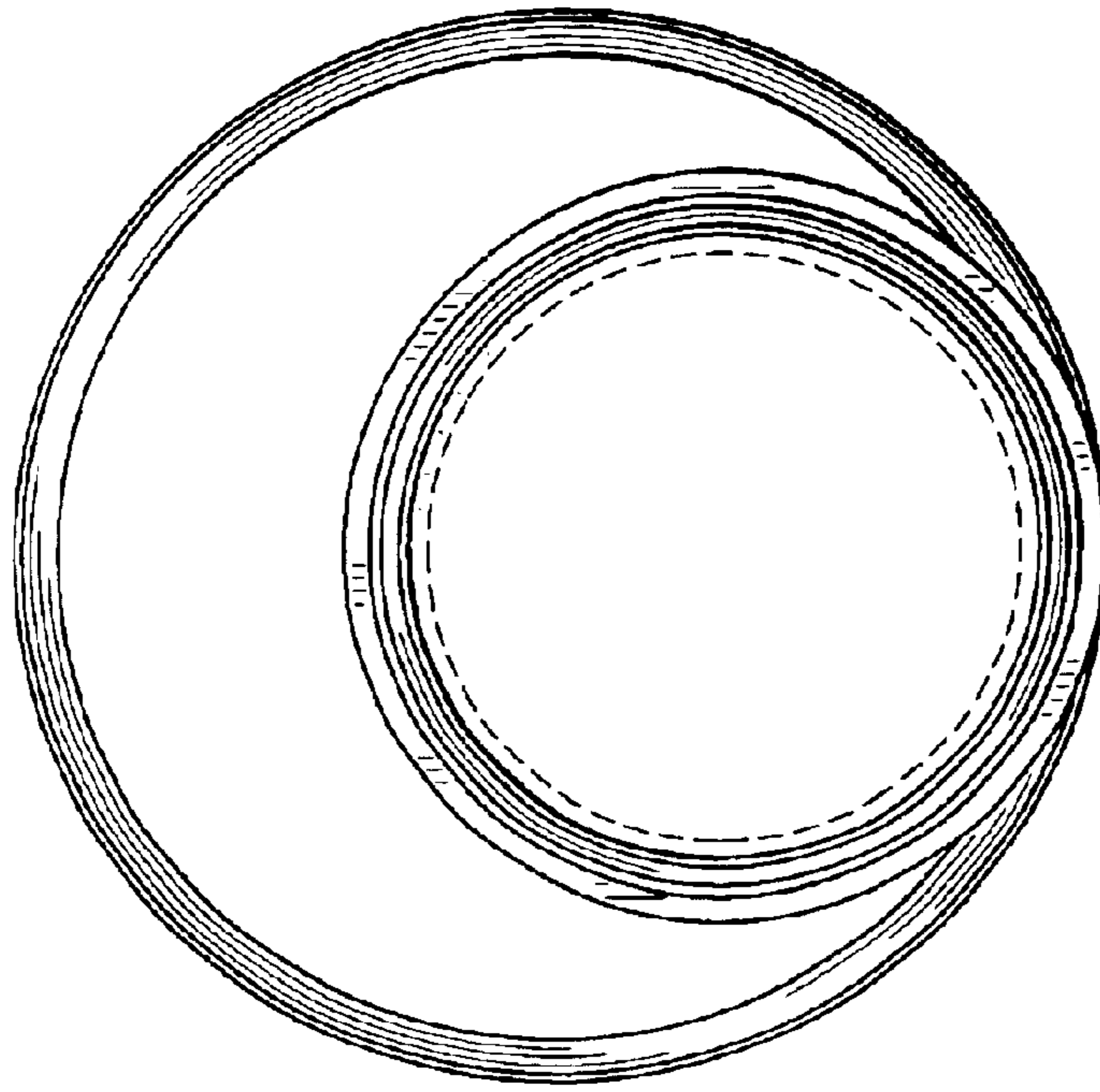

FIG. 12

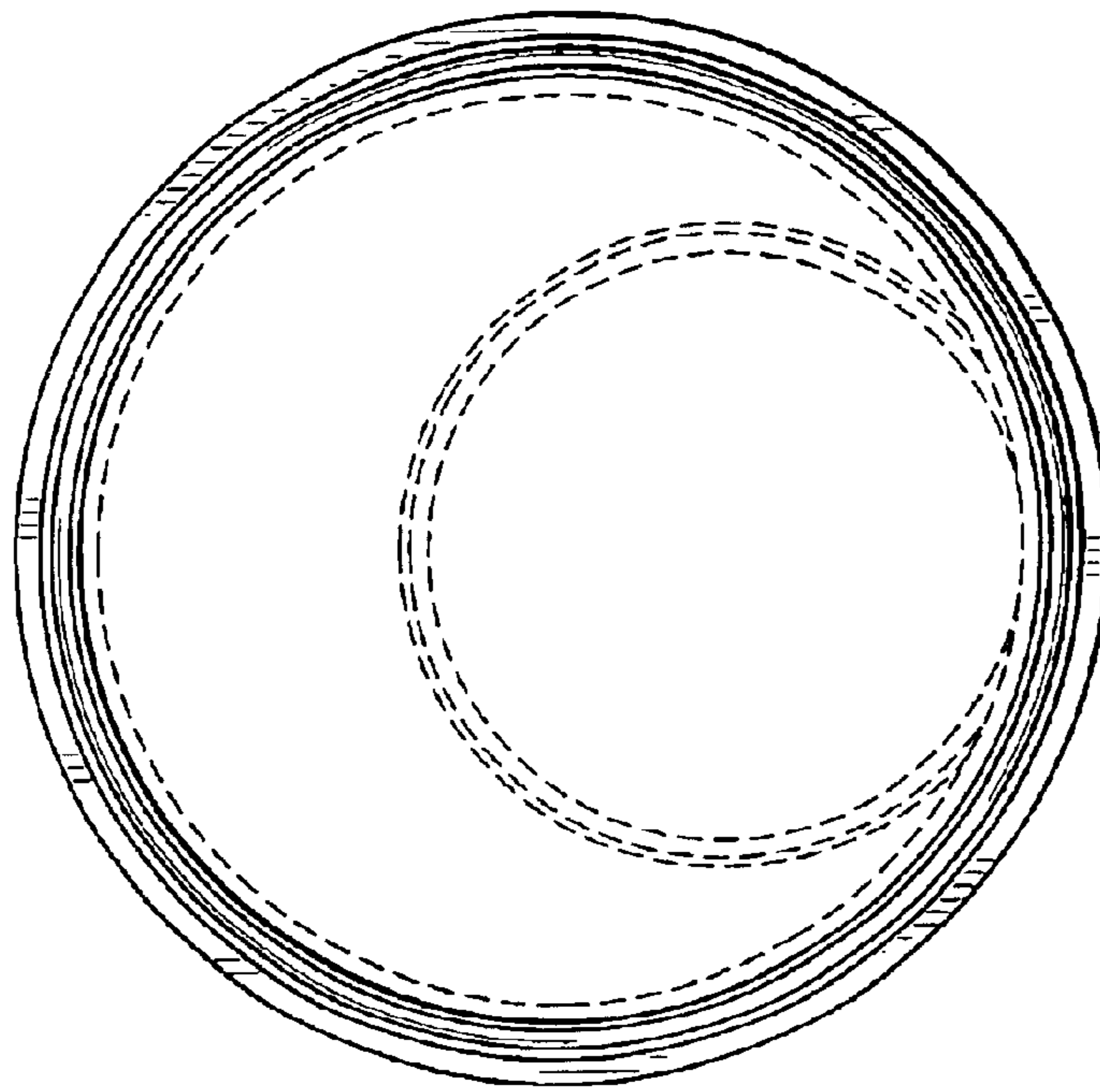

FIG. 11

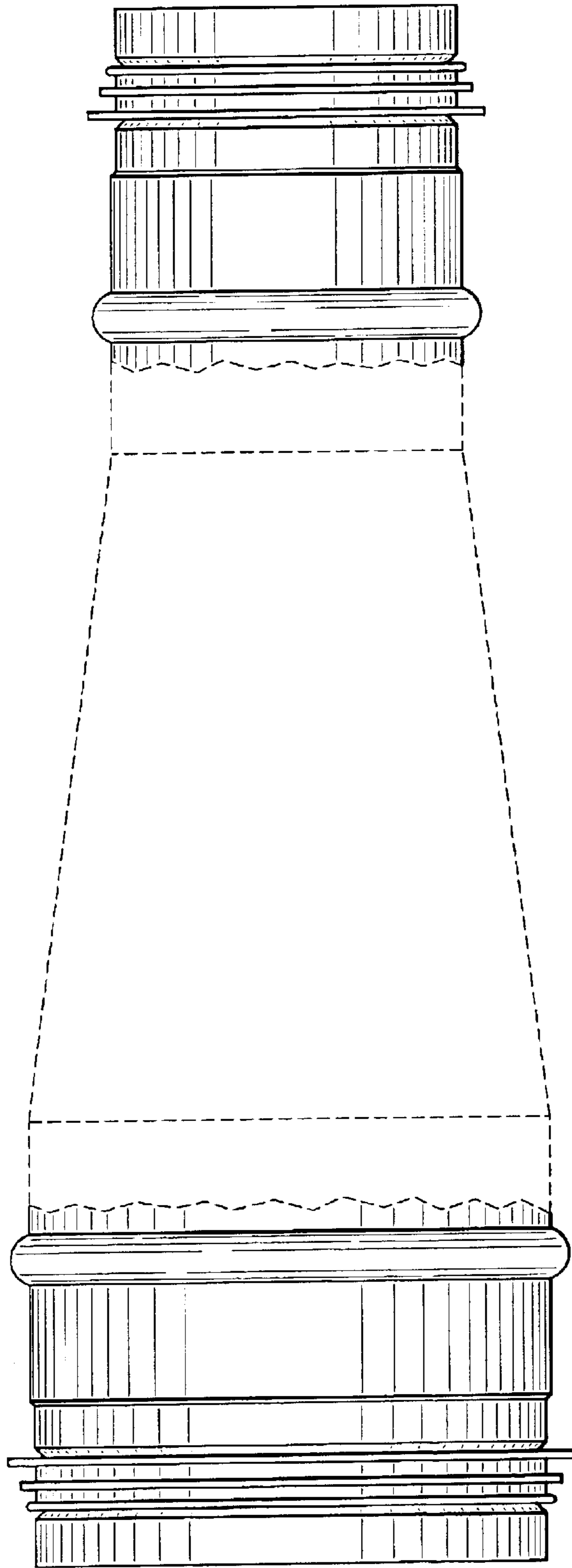

FIG. 13

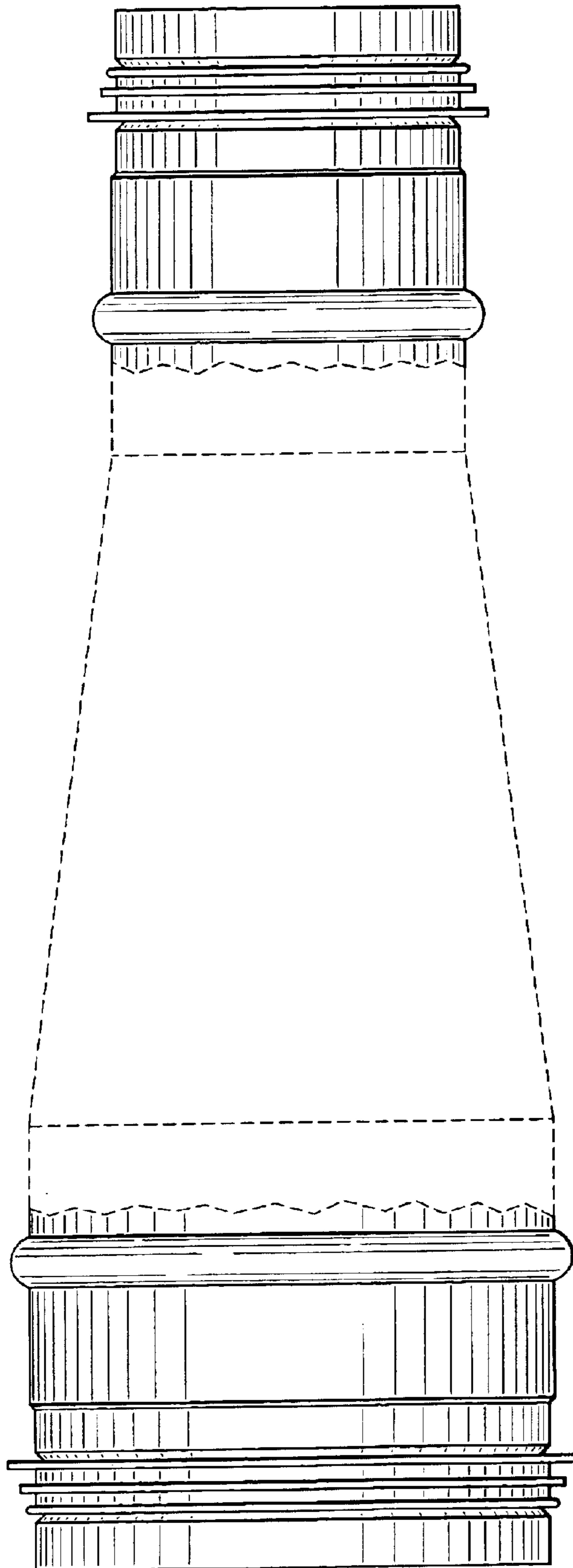

FIG. 14

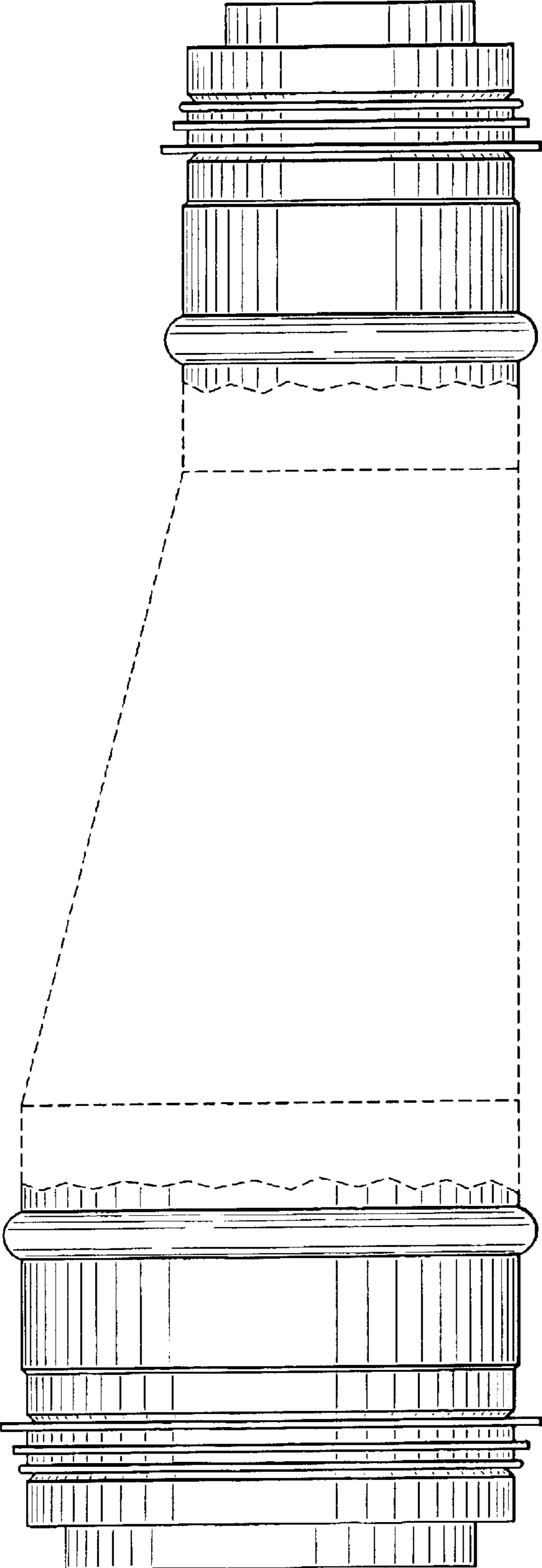

FIG. 15

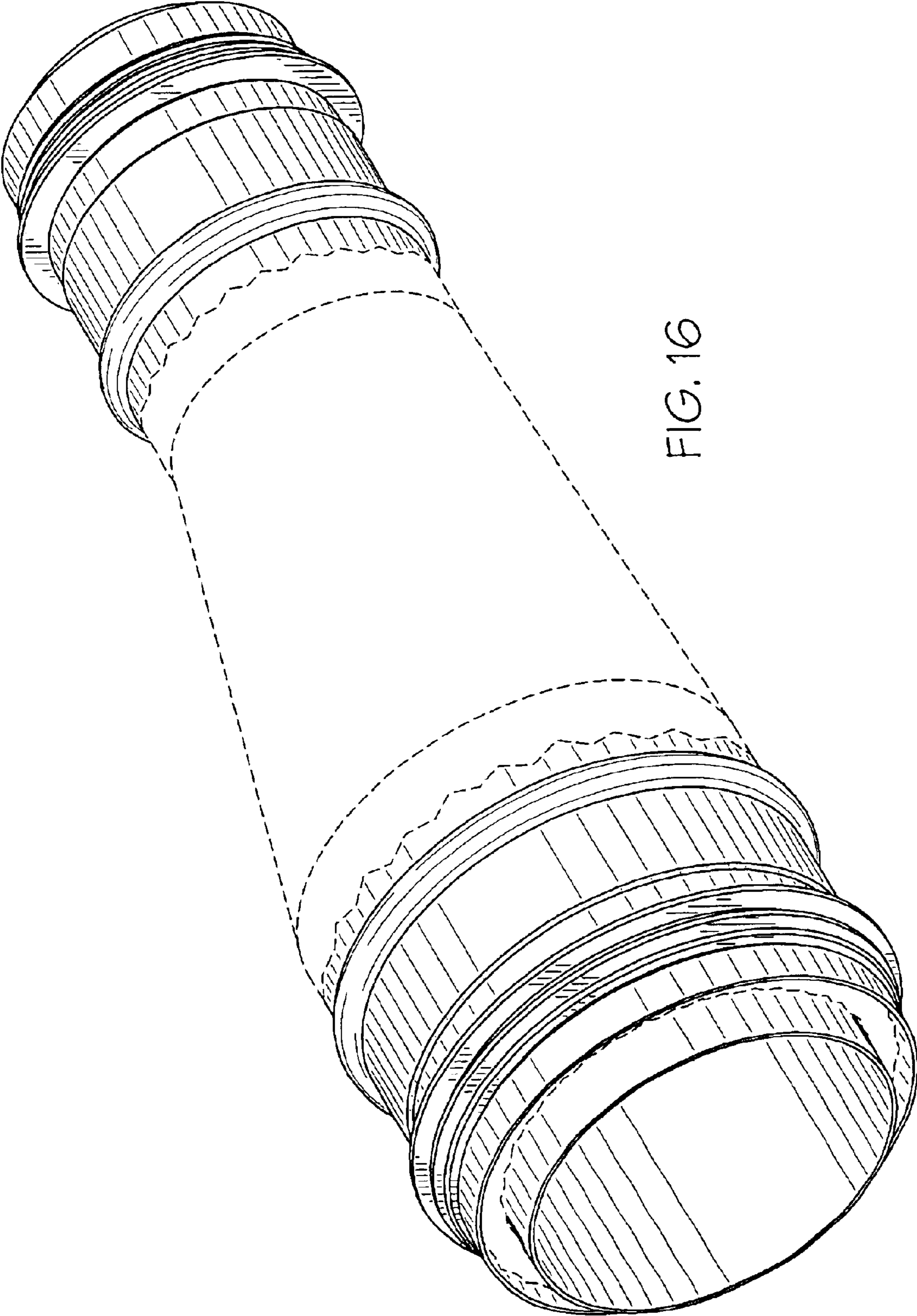

FIG. 16

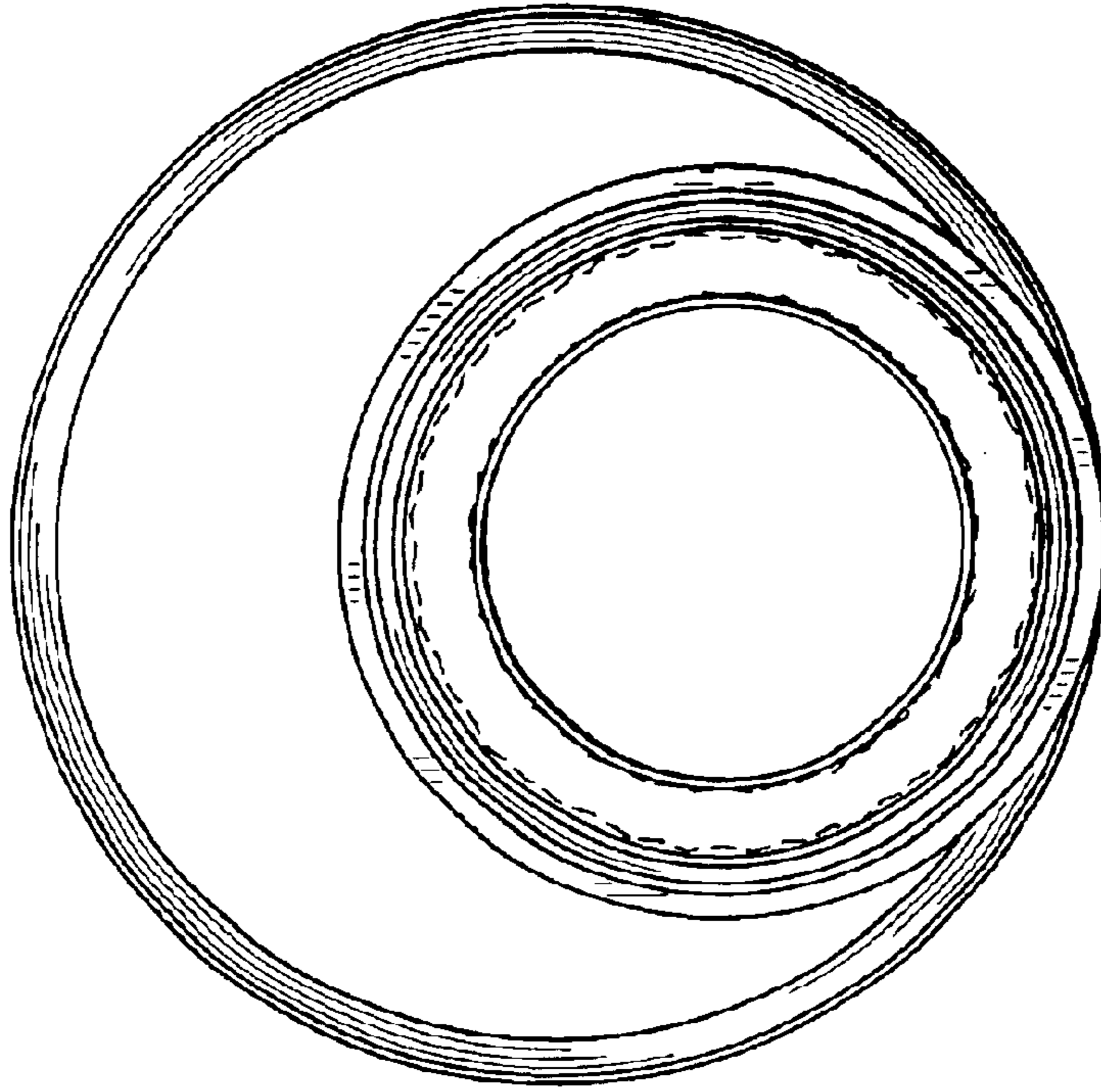

FIG. 18

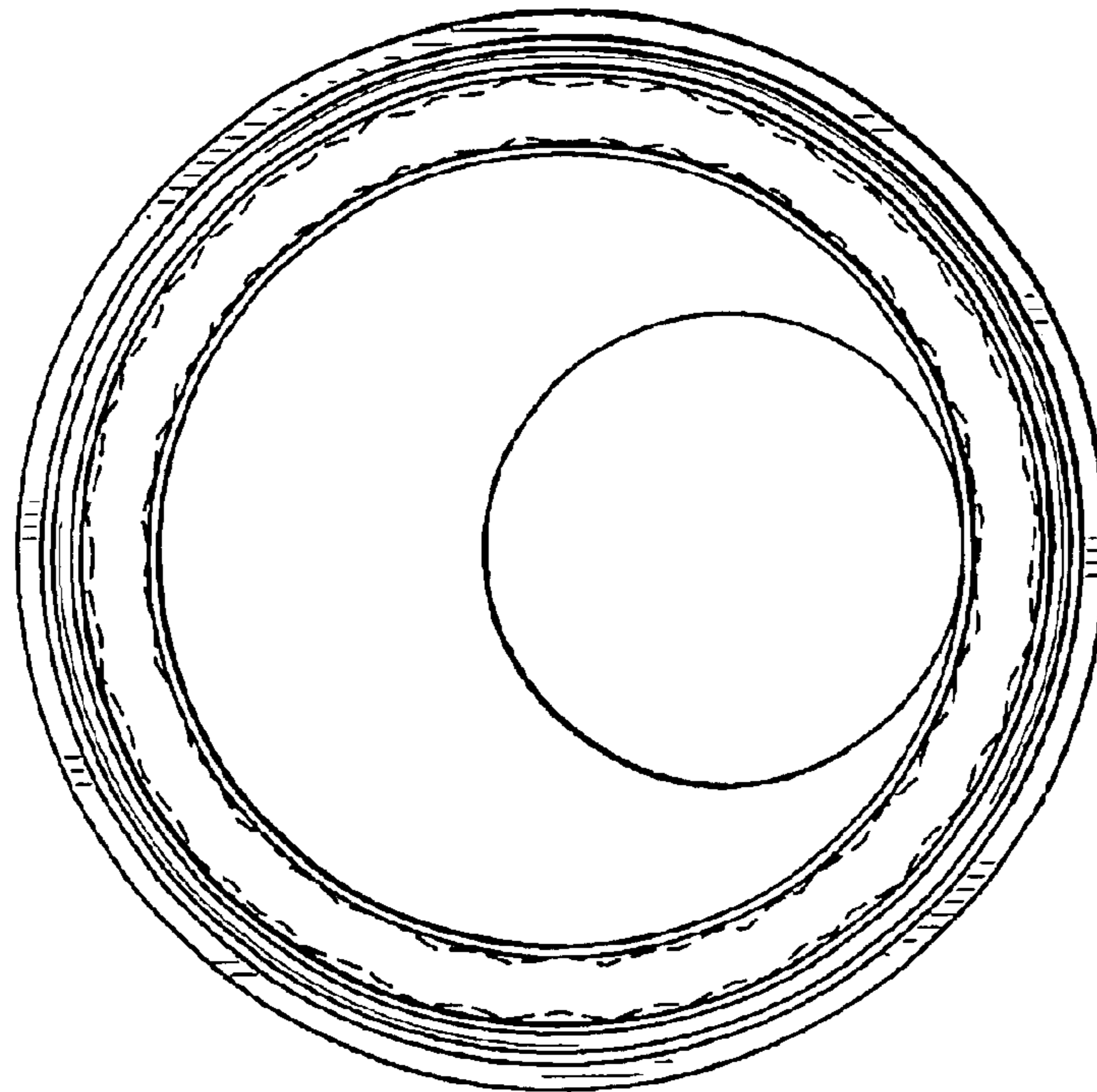

FIG. 17

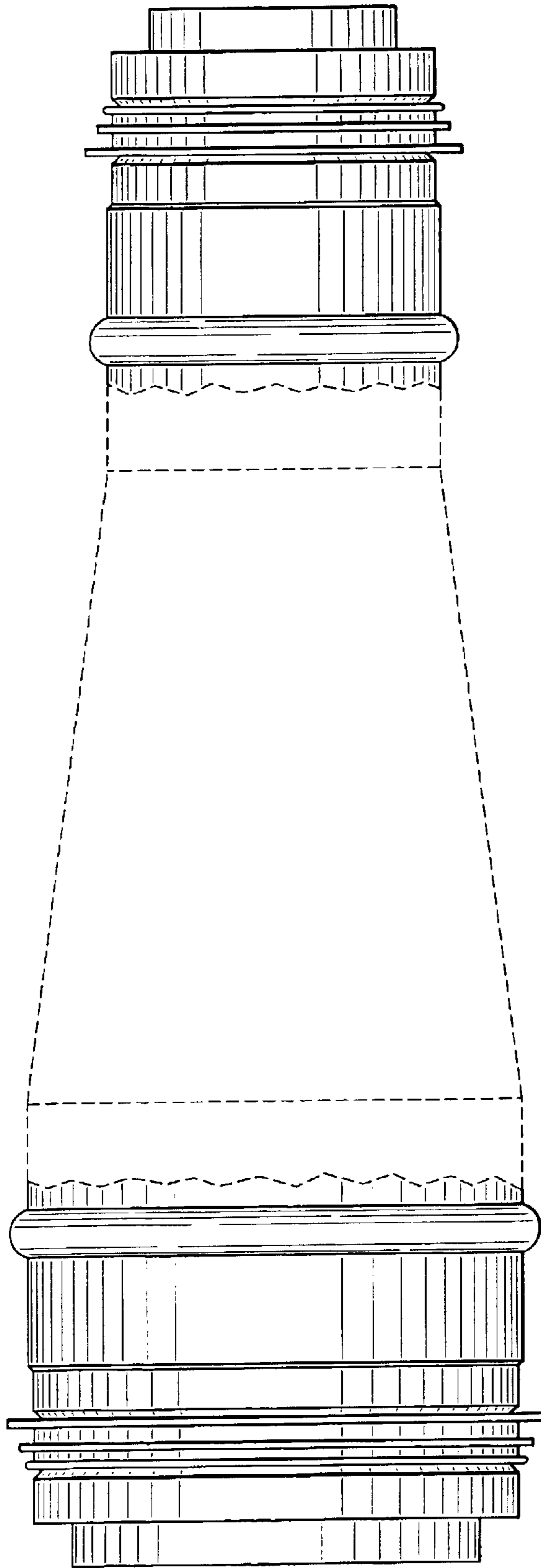

FIG. 19

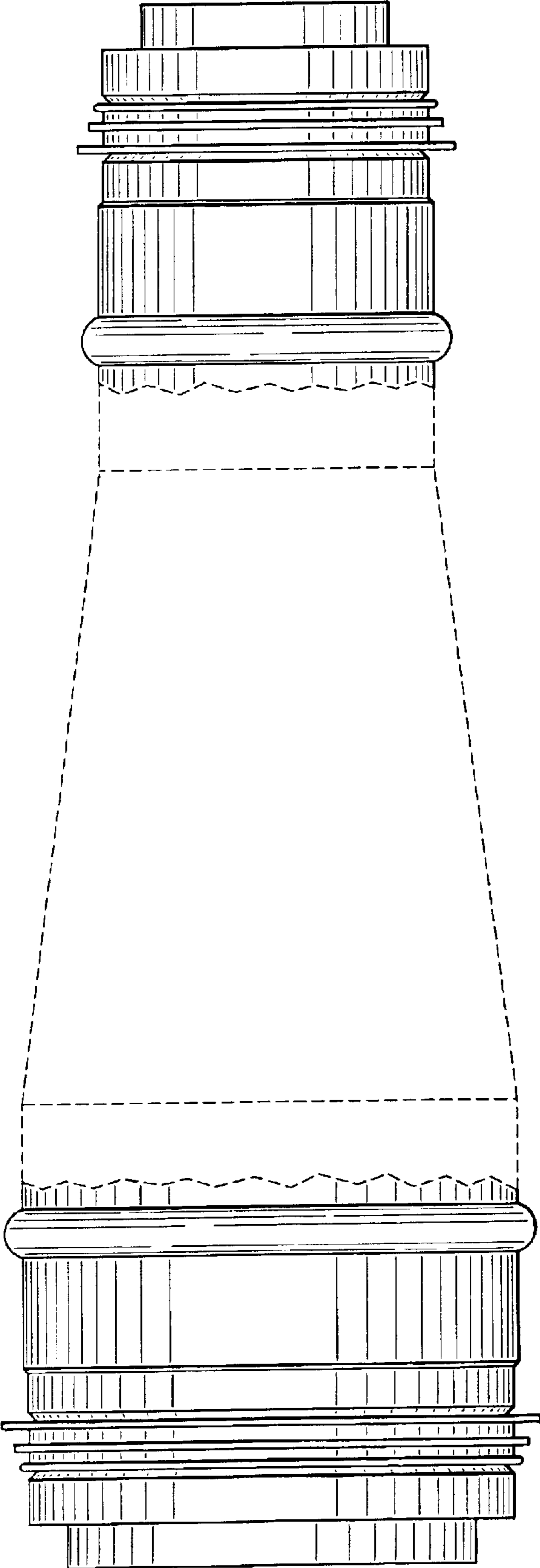

FIG. 20