

US00D491961S1

(12) **United States Design Patent**  
**Kazama**

(10) **Patent No.:** **US D491,961 S**  
(45) **Date of Patent:** **\*\* Jun. 22, 2004**

(54) **ROTARY GRINDING STONE**

(75) Inventor: **Kenichi Kazama**, Kamiminouchi-gun  
(JP)

(73) Assignee: **Shinano Electric Refining Co., Ltd.**,  
Tokyo (JP)

(\*\*) Term: **14 Years**

(21) Appl. No.: **29/181,410**

(22) Filed: **May 12, 2003**

(30) **Foreign Application Priority Data**

Apr. 17, 2003 (KR) ..... 30-2003-0010616

(51) **LOC (7) Cl.** ..... **15-09**

(52) **U.S. Cl.** ..... **D15/126**

(58) **Field of Search** ..... D15/126; 451/548,  
451/549-552; 407/29.13; D8/70

(56) **References Cited**

**U.S. PATENT DOCUMENTS**

3,019,570 A \* 2/1962 Olton ..... 451/510  
D196,447 S \* 10/1963 Zuzelo ..... D15/126  
4,023,313 A \* 5/1977 LeBlanc ..... 451/548

**OTHER PUBLICATIONS**

Japanese Publication dated Dec. 2, 1998.

\* cited by examiner

*Primary Examiner*—Antoine D. Davis

(74) *Attorney, Agent, or Firm*—Morgan, Lewis & Bockius  
LLP

(57) **CLAIM**

The ornamental design for a rotary grinding stone, as shown  
and described.

**DESCRIPTION**

FIG. 1 is a perspective view of a rotary grinding stone  
having a centrally disposed hole according to the new  
design.

FIG. 2 is a front side view of the rotary grinding stone of  
FIG. 1;

FIG. 3 is a right side view of the rotary grinding stone of  
FIG. 1;

FIG. 4 is a rear side view of the rotary grinding stone of FIG.  
1;

FIG. 5 is a left side view of the rotary grinding stone of FIG.  
1;

FIG. 6 is a top view of the rotary grinding stone of FIG. 1;

FIG. 7 is a bottom view of the rotary grinding stone of FIG.  
1; and,

FIG. 8 is a cross-sectional view of the rotary grinding stone  
of FIG. 1, taken at section A—A in FIG. 6.

**1 Claim, 3 Drawing Sheets**

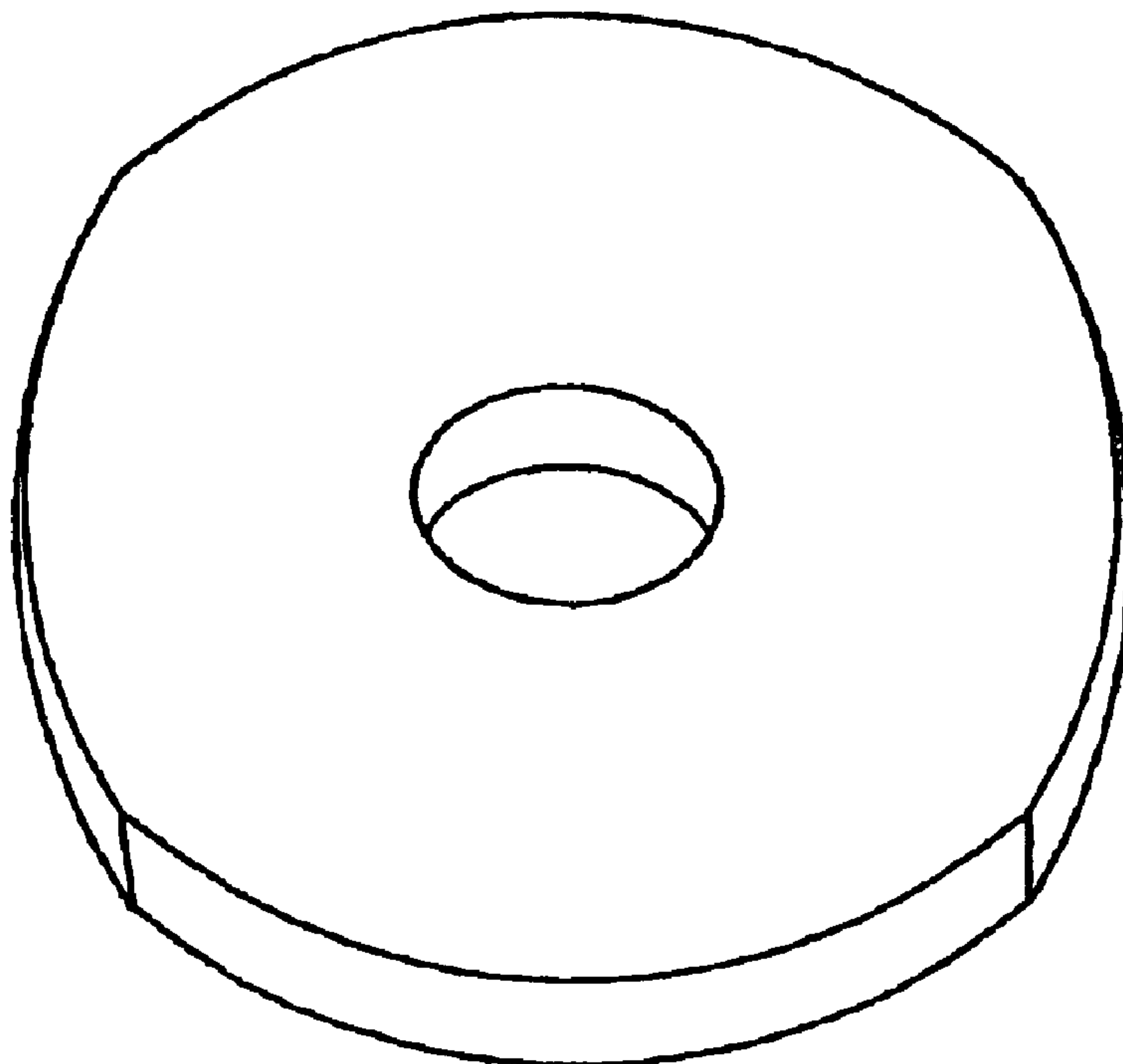

FIG. 1

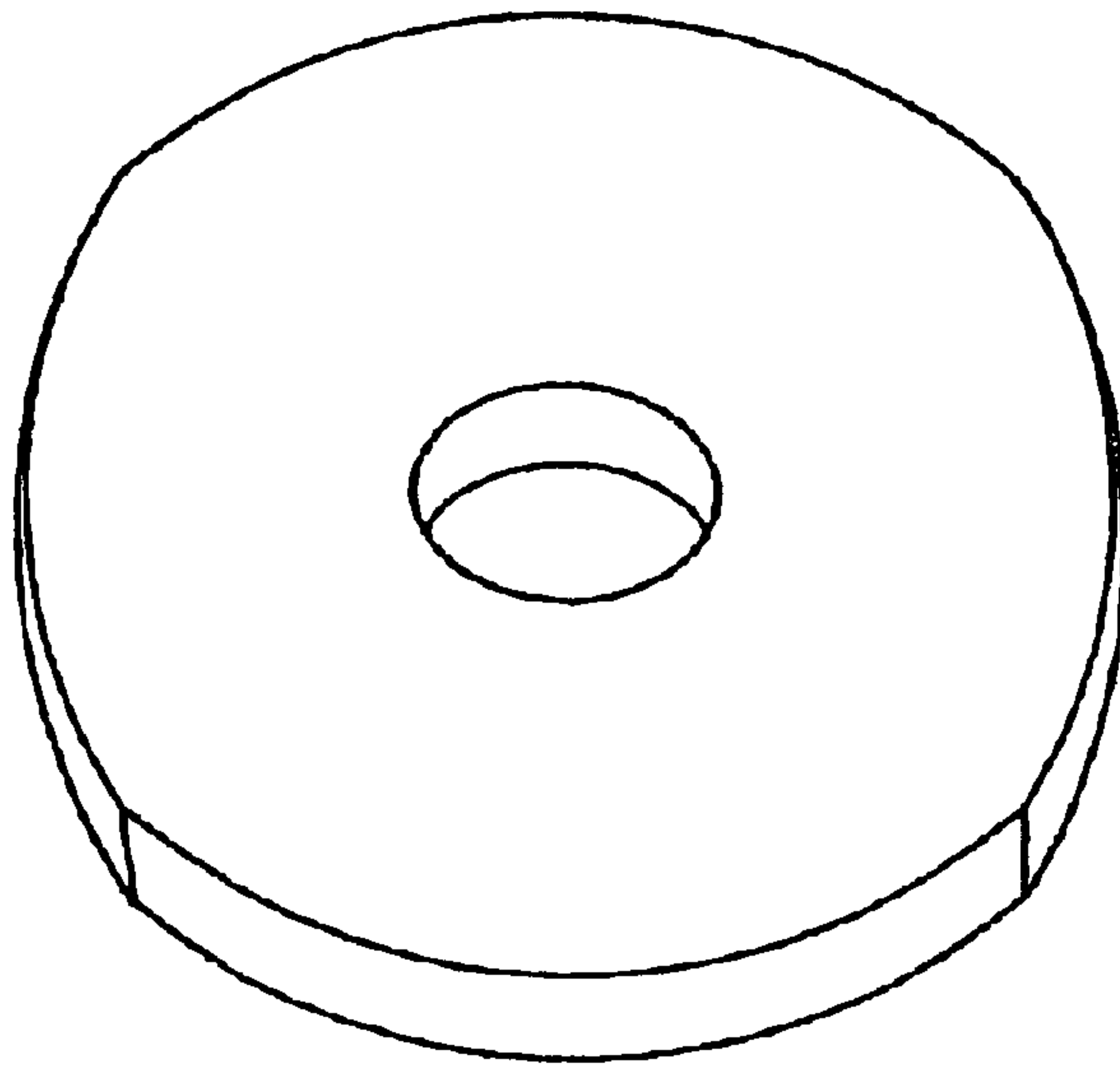

FIG. 2



FIG. 3



FIG. 4



FIG. 5

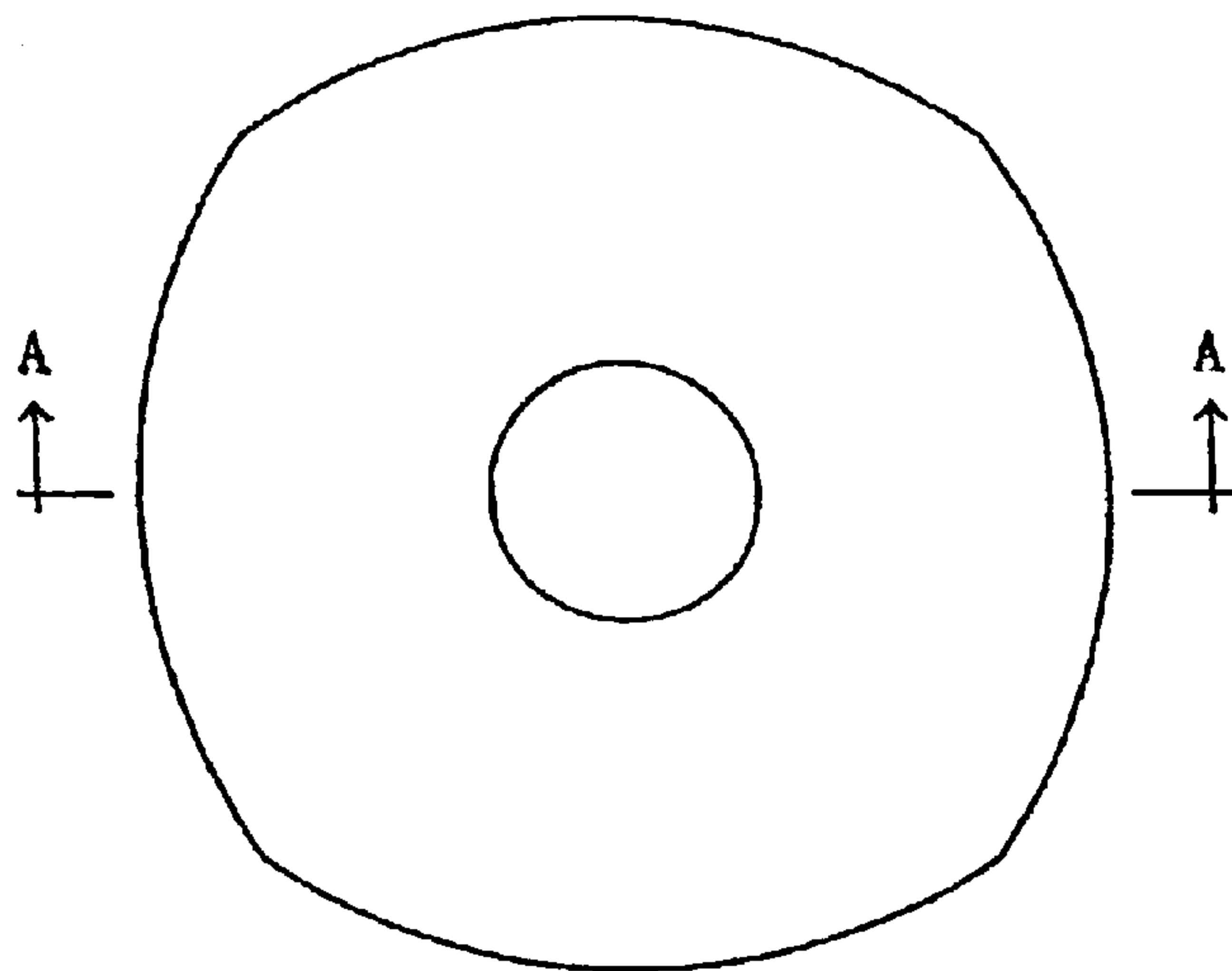

FIG. 6

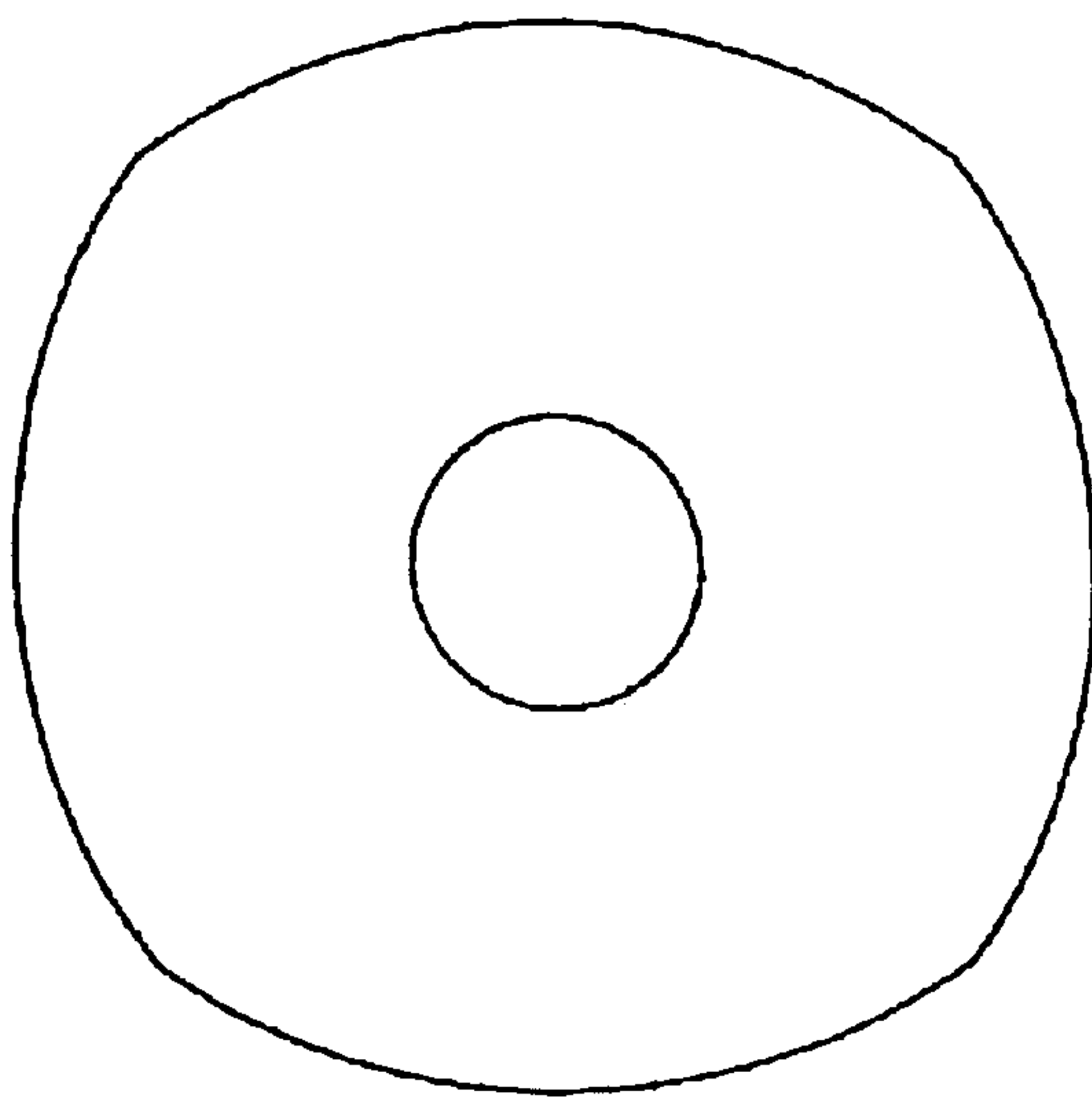

FIG. 7



FIG. 8