

US00D491875S1

(12) **United States Design Patent**
Eatkins et al.

(10) **Patent No.: US D491,875 S**
(45) **Date of Patent: ** Jun. 22, 2004**

(54) **COMMERCIAL JET TRANSPORT**

(75) Inventors: **Mark Eatkins**, Kirland, WA (US); **Paul Dees**, Woodinville, WA (US); **Blake Emery**, Enumclaw, WA (US); **Chris B. Kettering**, Kirkland, WA (US); **Kevin Retz**, Bothell, WA (US); **Paul Mikulencak**, Everett, WA (US)

(73) Assignee: **The Boeing Company**, Chicago, IL (US)

(**) Term: **14 Years**

(21) Appl. No.: **29/181,153**

(22) Filed: **May 5, 2003**

(51) **LOC (7) Cl.** **12-12**

(52) **U.S. Cl.** **D12/319**

(58) **Field of Search** D12/319-345;
244/12.5, 13, 15, 55, 65

(56) **References Cited**

U.S. PATENT DOCUMENTS

D386,143 S * 11/1997 Astaire D12/319
D469,054 S * 1/2003 Fujino D12/319

OTHER PUBLICATIONS

Pamphlet: Plane Spotter: Your Guide to Passenger Airlines©1999.

Bill Yenne, The Story of the Boeing Company, AGS Book-Works, San Francisco, CA ©2003.

* cited by examiner

Primary Examiner—Marcus A. Jackson

(74) *Attorney, Agent, or Firm*—Ann K. Galbraith

(57) **CLAIM**

The ornamental design for, an commercial jet transport, as shown and described.

DESCRIPTION

FIG. 1 is a front-side elevation view, both sides being identical, of an commercial jet transport showing my new design;

FIG. 2 is a top elevation view thereof;

FIG. 3 is a front elevation view thereof;

FIG. 4 is a top plan view; and,

FIG. 5 is a side elevation view.

The design feature is the exterior configuration of an airplane.

1 Claim, 3 Drawing Sheets

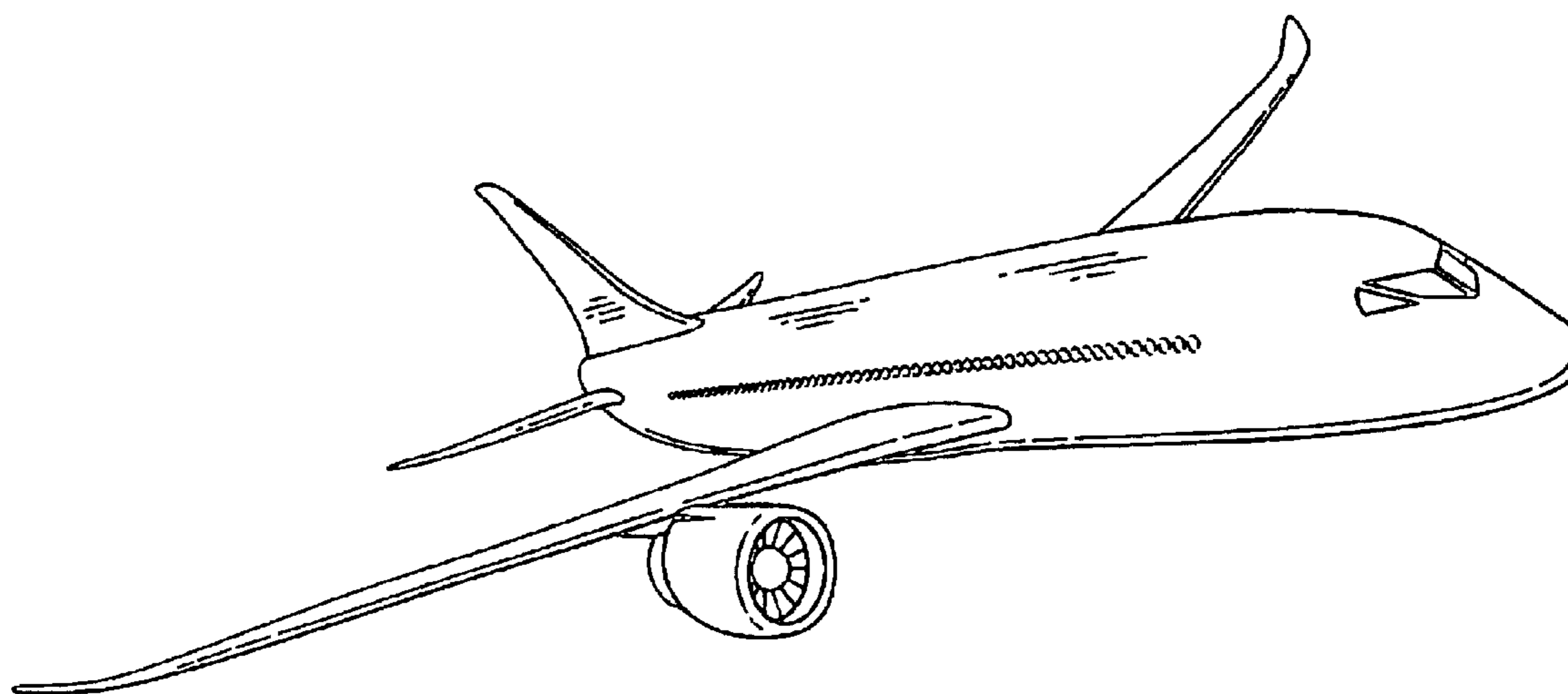

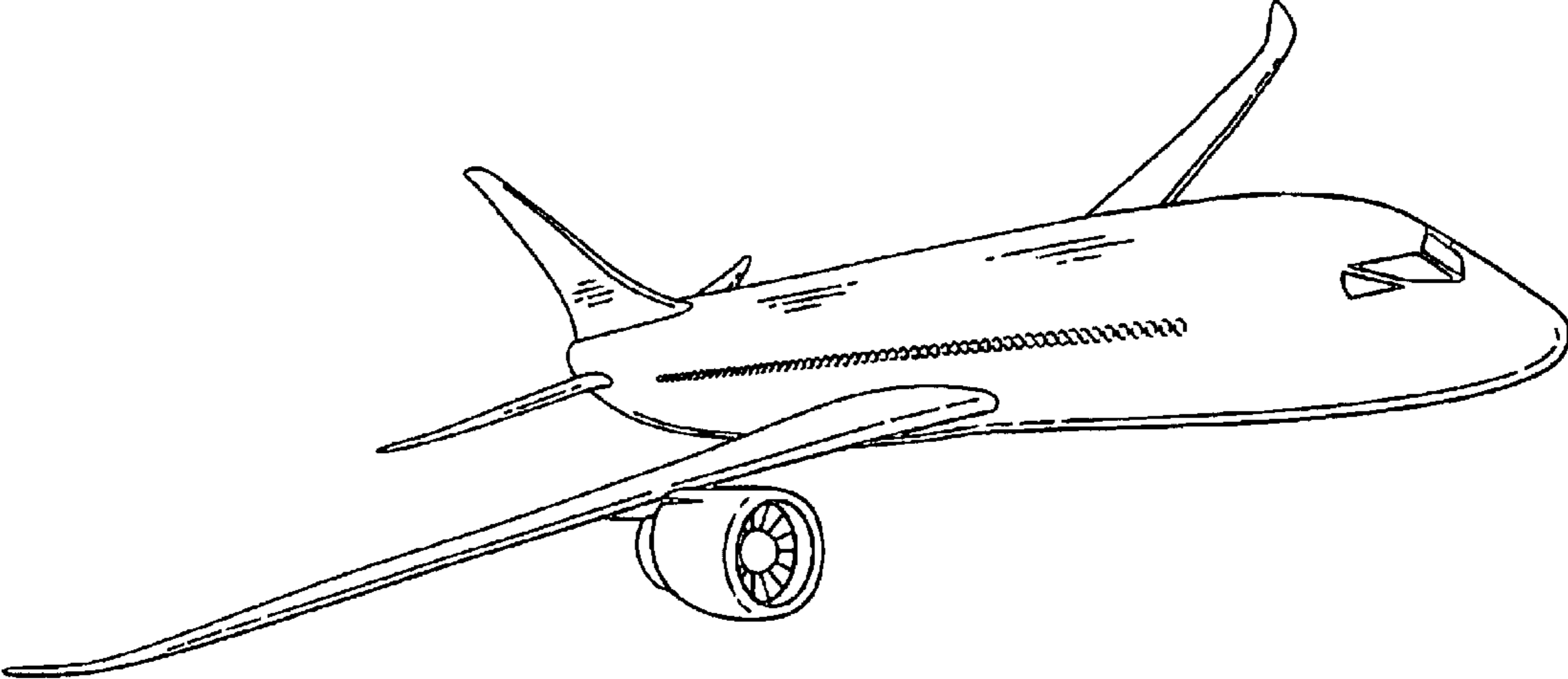

FIG. 1

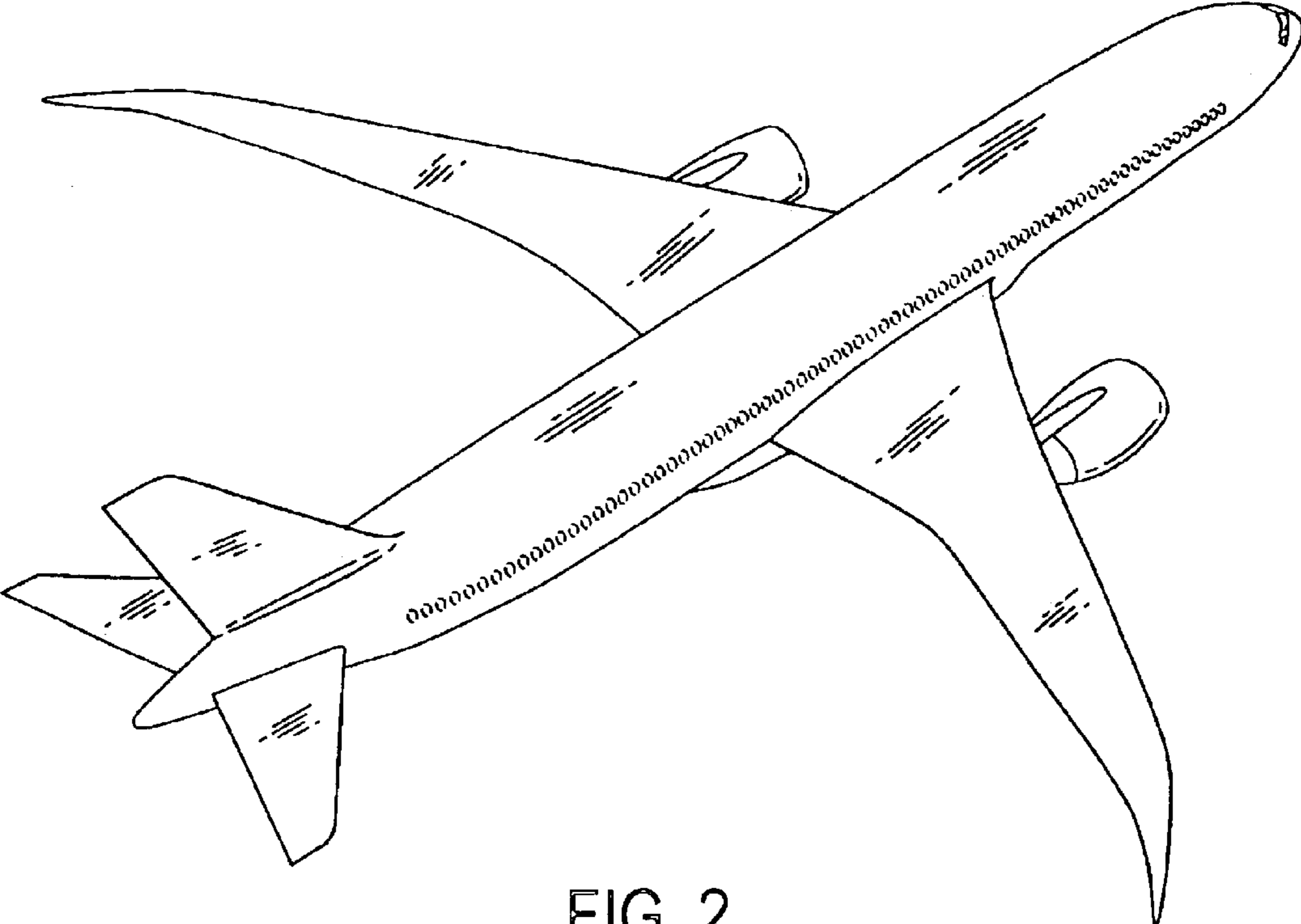

FIG. 2

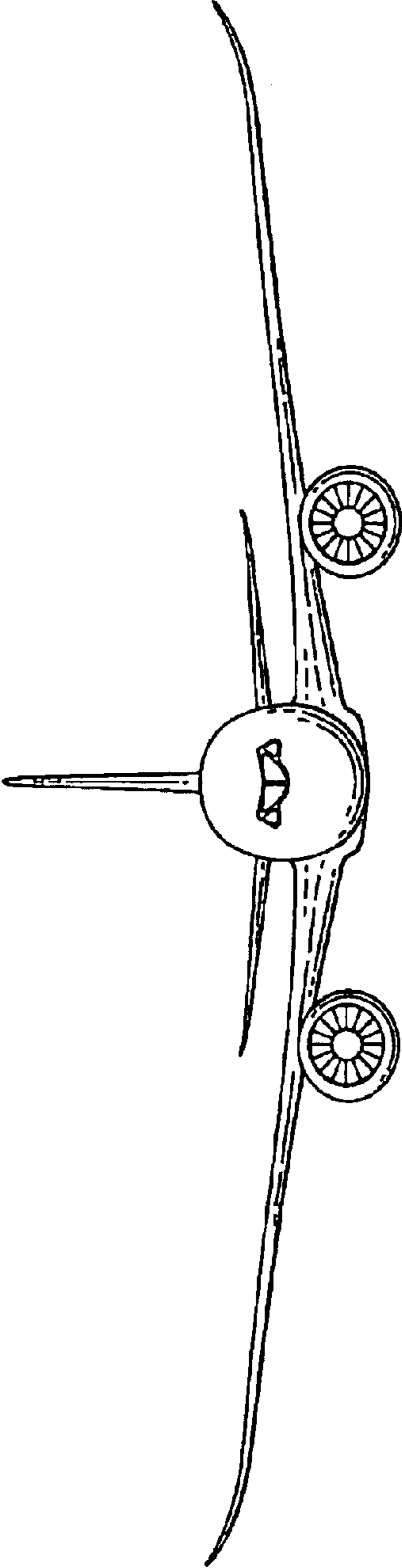

FIG. 3

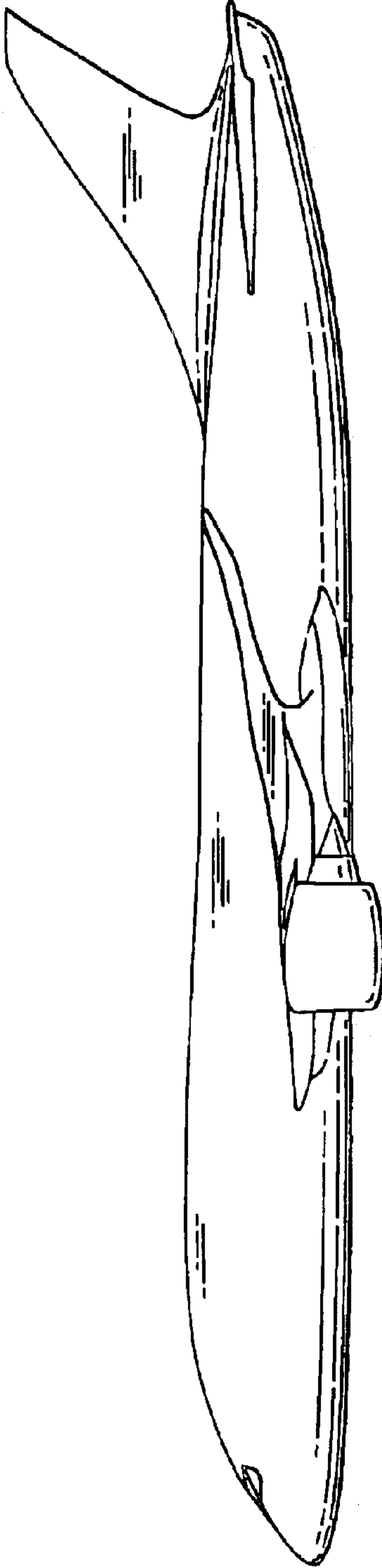

FIG. 5

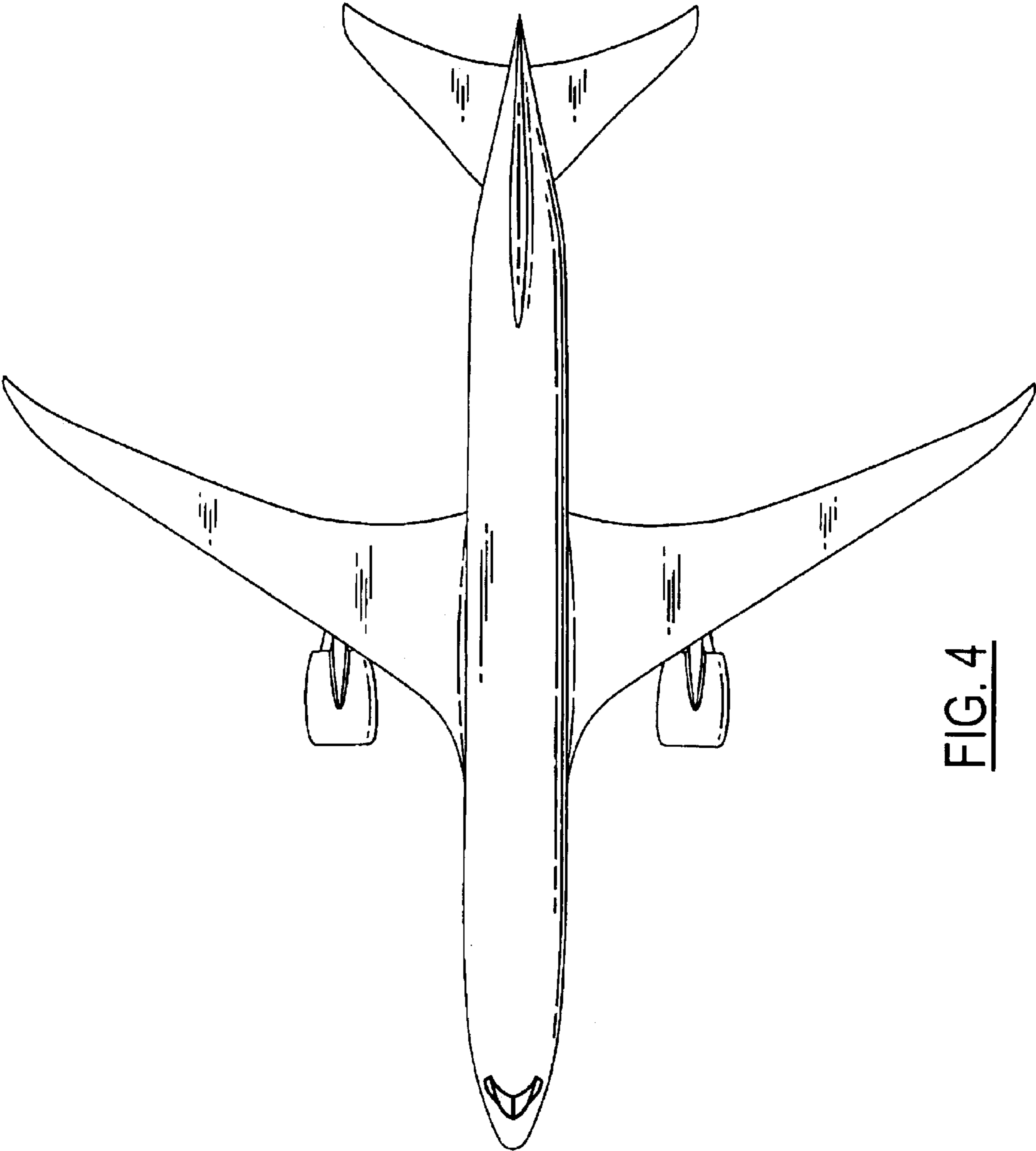

FIG. 4