

US00D491860S1

(12) **United States Design Patent** (10) **Patent No.:** **US D491,860 S**  
**Velazco** (45) **Date of Patent:** **\*\* Jun. 22, 2004**

(54) **SURFACE CONFIGURATION OF A DOOR FOR A VEHICLE**

(75) **Inventor:** **Geoffrey Antenor Velazco**, Venice, CA (US)

(73) **Assignee:** **Bayerische Motoren Werke Aktiengesellschaft**, Munich (DE)

(\*\*) **Term:** **14 Years**

(21) **Appl. No.:** **29/180,267**

(22) **Filed:** **Apr. 22, 2003**

(30) **Foreign Application Priority Data**

Oct. 23, 2002 (DE) ..... 4 02 08 872

(51) **LOC (7) Cl.** ..... **12-16**

(52) **U.S. Cl.** ..... **D12/196**

(58) **Field of Search** ..... D12/196, 86, 90-92; 296/185

(56) **References Cited**

**U.S. PATENT DOCUMENTS**

D418,471 S \* 1/2000 Gabath ..... D12/196

D467,849 S \* 12/2002 Murkett ..... D12/196

D479,170 S \* 9/2003 Boyer ..... D12/196

\* cited by examiner

*Primary Examiner*—Melody N. Brown

(74) *Attorney, Agent, or Firm*—Crowell & Moring LLP

(57) **CLAIM**

The ornamental design for a surface configuration of a door for a vehicle, as shown and described.

**DESCRIPTION**

This application is related to co-pending Application Ser. No. 29/180,269, of the inventor, entitled "Surface Configuration of a Vehicle, Toy and/or Other Replicas".

FIG. 1 is a front view of a first embodiment of a surface configuration of a door for a vehicle according to my novel design;

FIG. 2 is a left perspective view of the first embodiment of the surface configuration of a door for a vehicle according to my novel design;

FIG. 3 is a right perspective view of the first embodiment of the surface configuration of a door for a vehicle according to my novel design;

FIG. 4 is a front view of a second embodiment of the surface configuration of a door for a vehicle according to my novel design;

FIG. 5 is a right perspective view of the second embodiment of the surface configuration of a door for a vehicle according to my novel design; and,

FIG. 6 is a left perspective view of the second embodiment of the surface configuration of a door for a vehicle according to my novel design.

The broken lines are for illustrative purposes only and form no part of the claimed design.

**1 Claim, 4 Drawing Sheets**

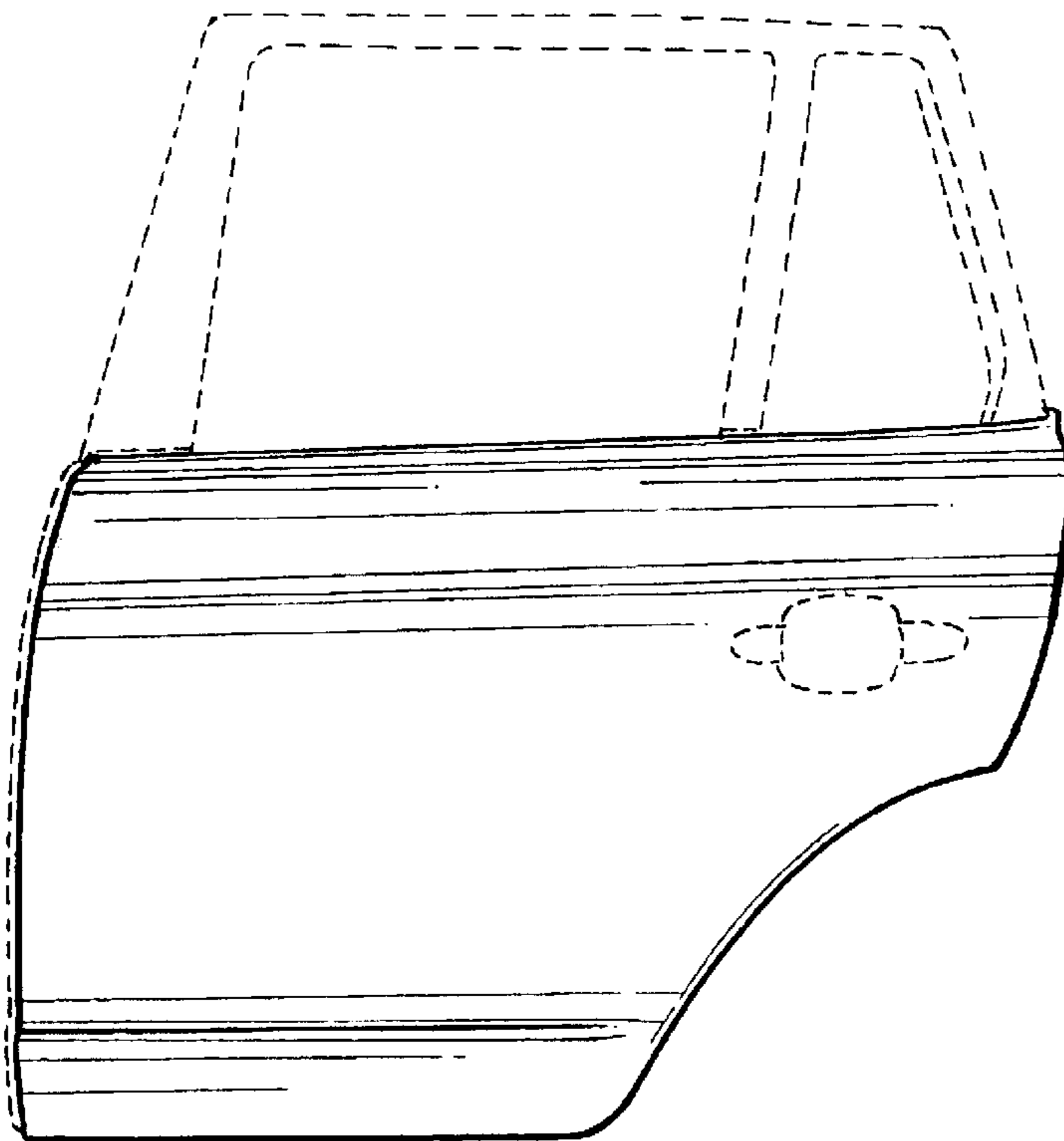

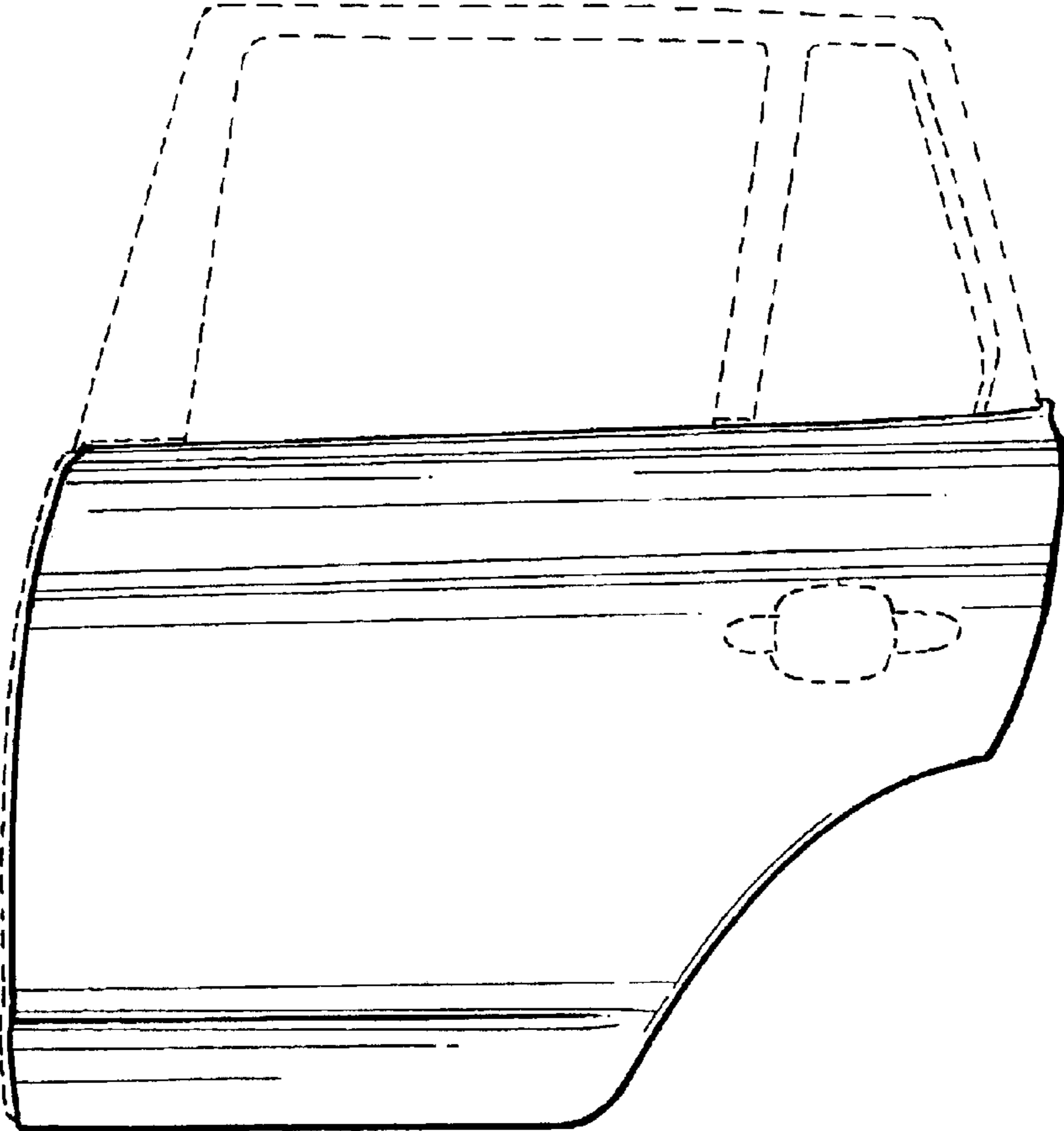

FIG. 1

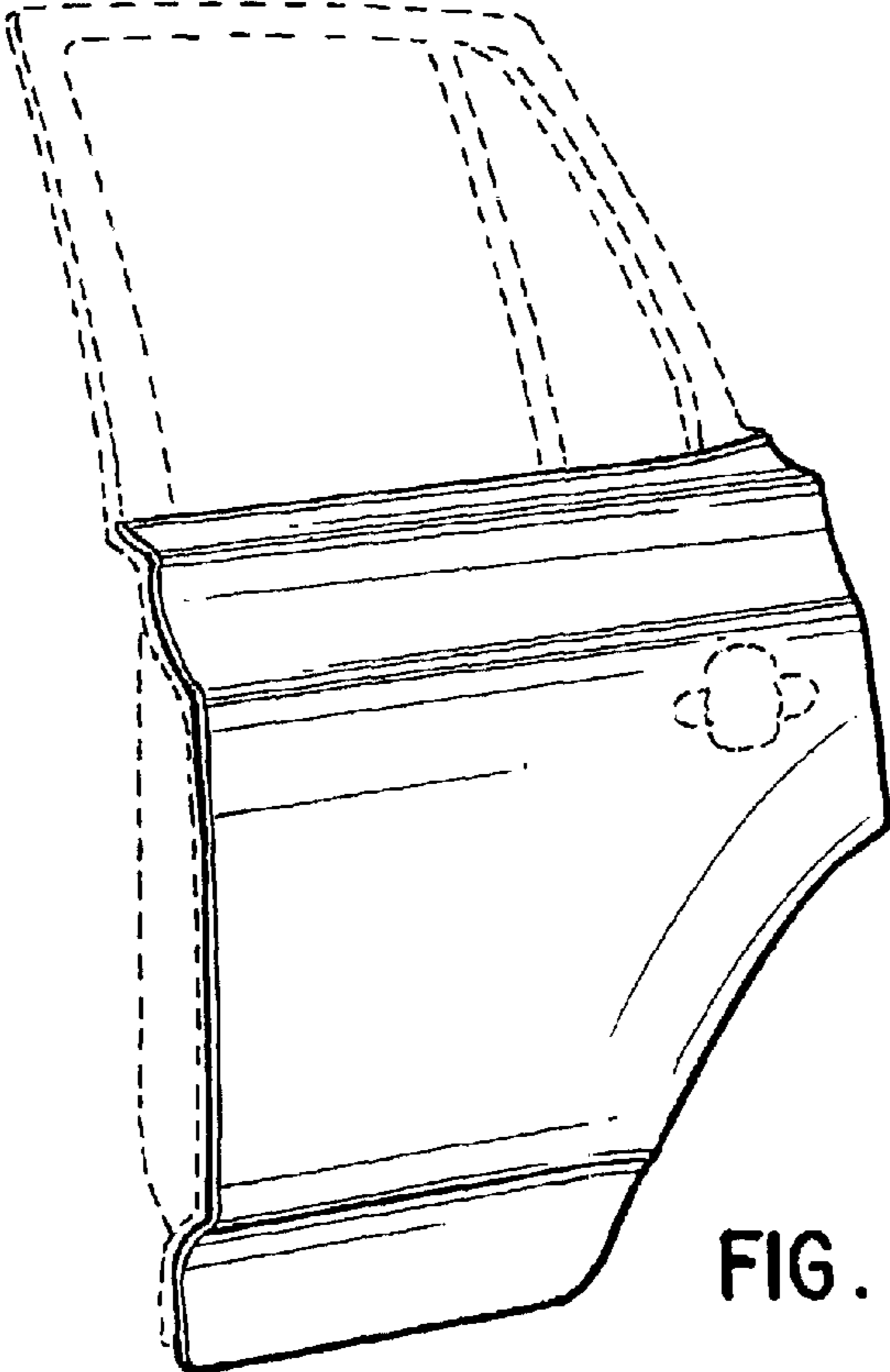

FIG. 2

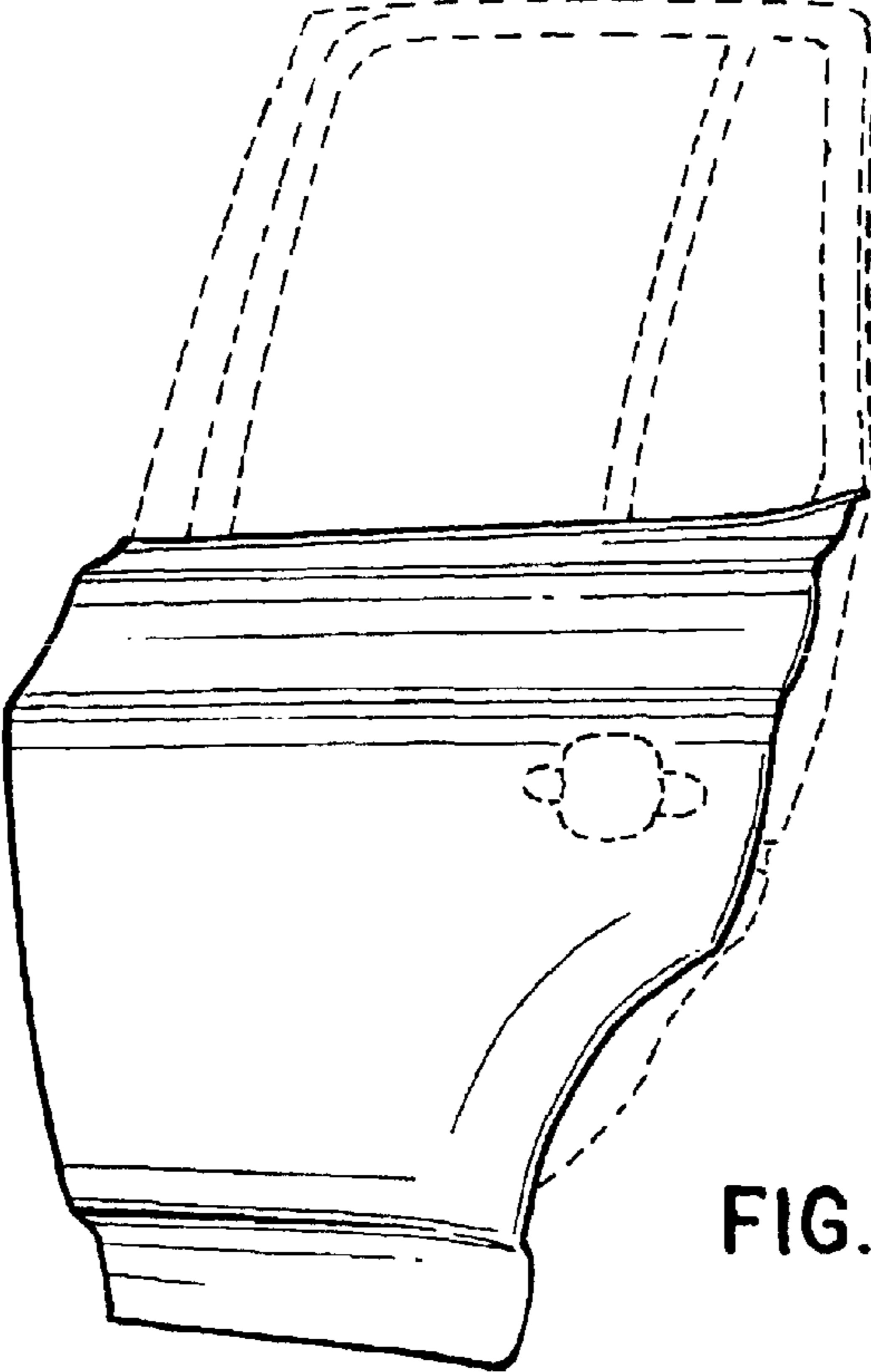

FIG. 3

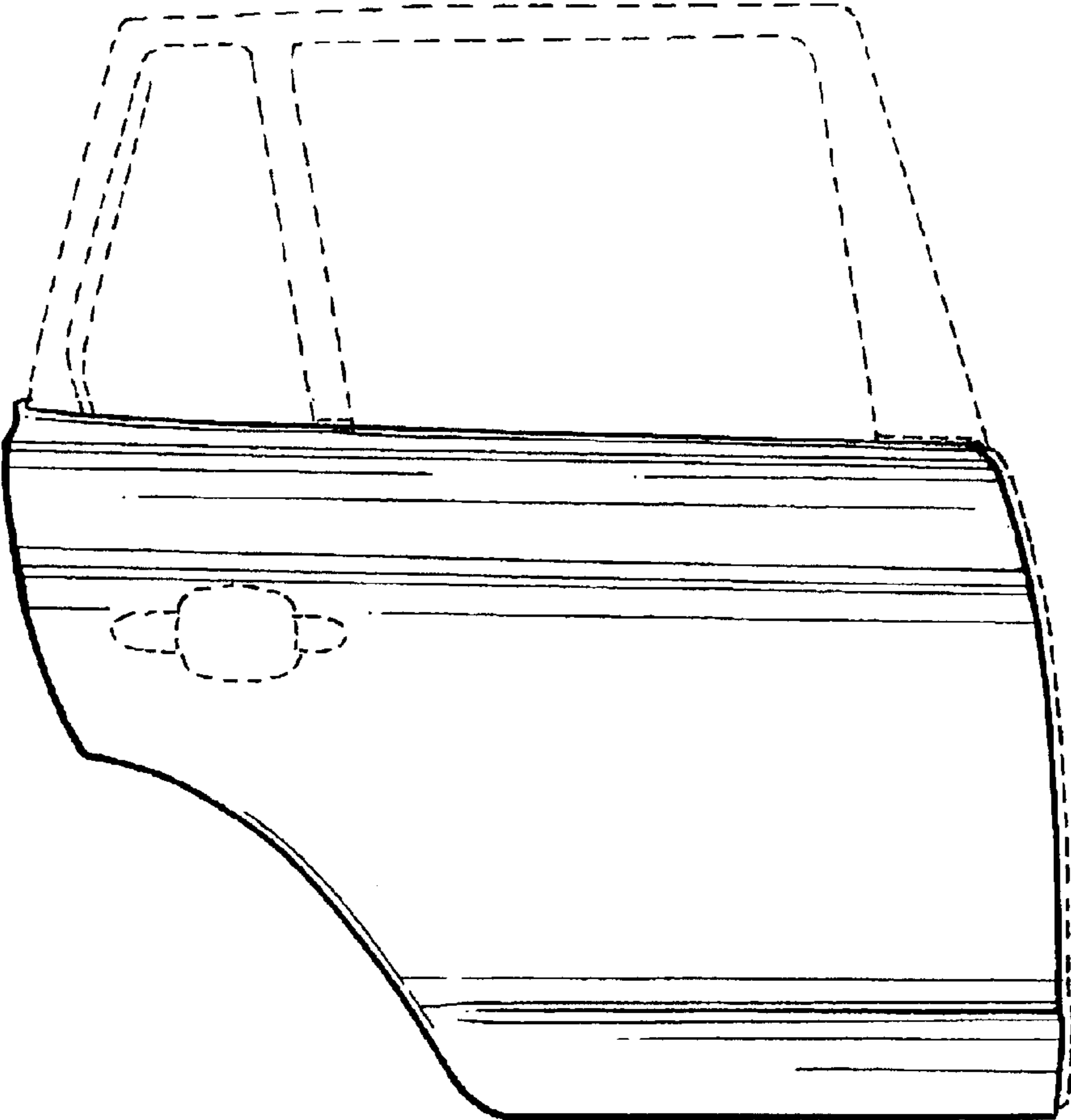

FIG. 4

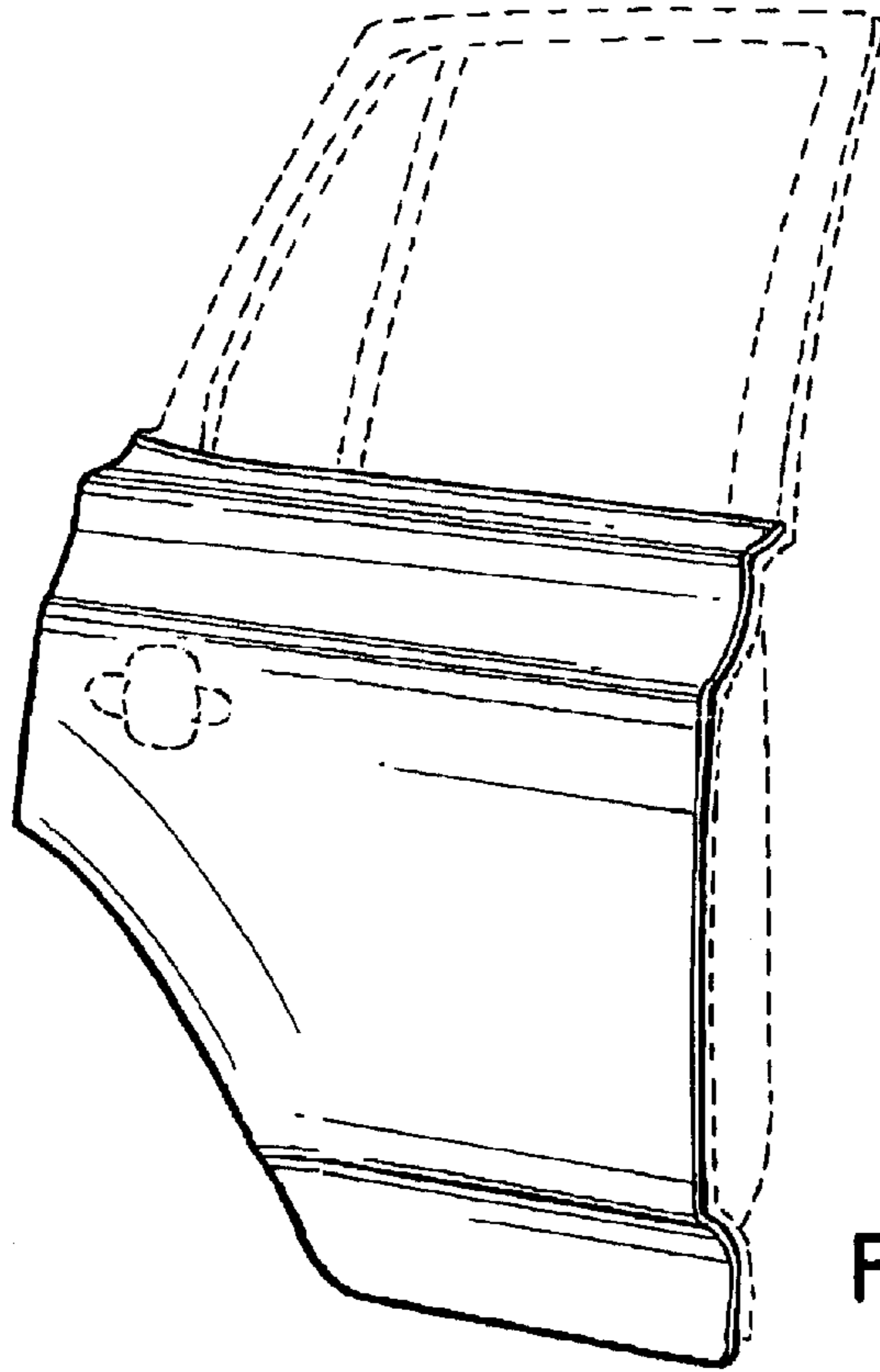

FIG. 5

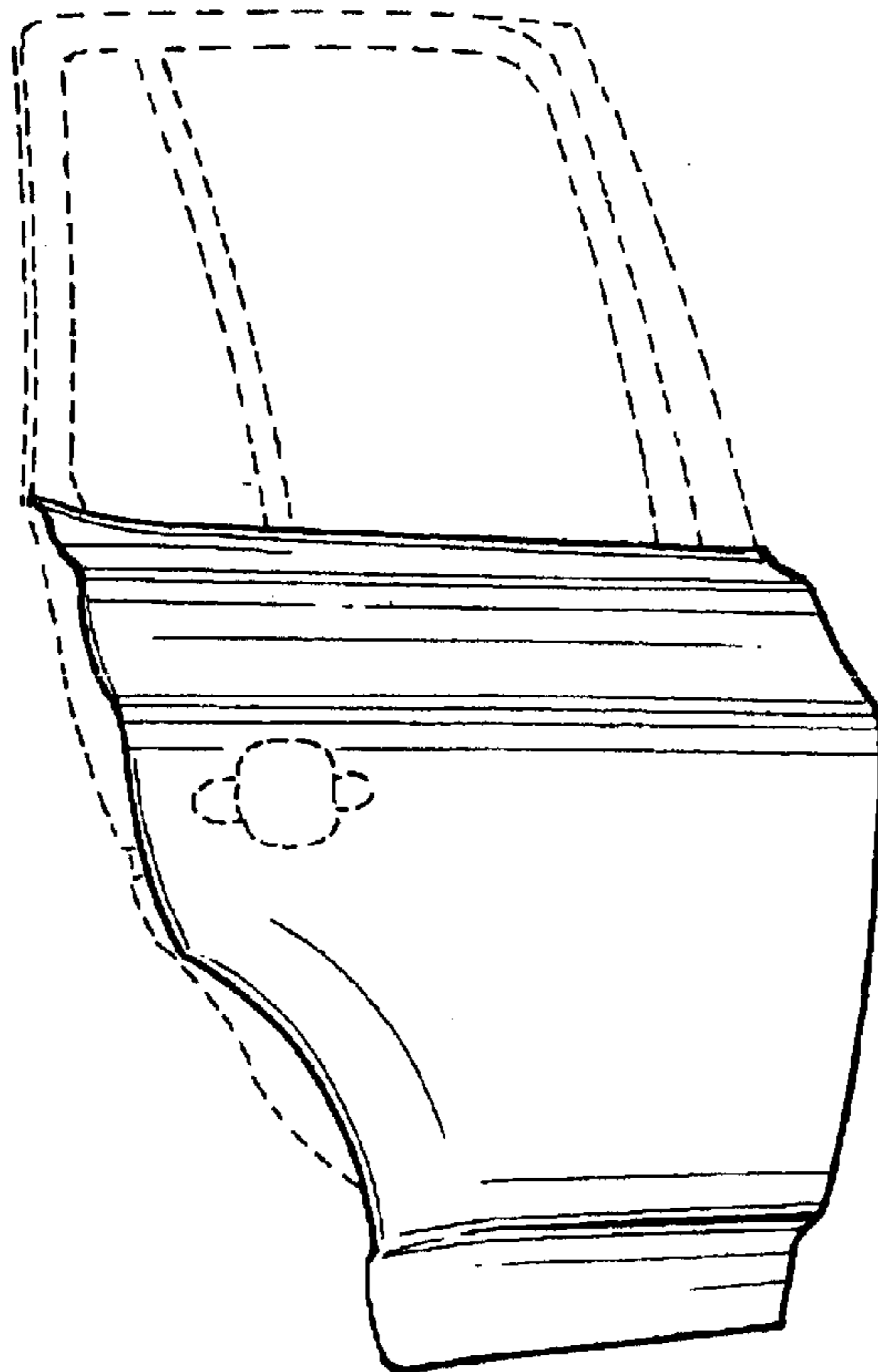

FIG. 6