

US00D491858S1

(12) **United States Design Patent**
Velazco

(10) **Patent No.:** **US D491,858 S**
(45) **Date of Patent:** **** Jun. 22, 2004**

(54) **SURFACE CONFIGURATION OF TRIM FOR A WHEEL WELL FOR A VEHICLE**

(75) **Inventor:** **Geoffrey Antenor Velazco**, Venice, CA (US)

(73) **Assignee:** **Bayerische Motoren Werke Aktiengesellschaft**, Munich (DE)

(**) **Term:** **14 Years**

(21) **Appl. No.:** **29/180,247**

(22) **Filed:** **Apr. 22, 2003**

(30) **Foreign Application Priority Data**

Oct. 23, 2002 (DE) 4 02 08 872

(51) **LOC (7) Cl.** **12-16**

(52) **U.S. Cl.** **D12/196; D12/184**

(58) **Field of Search** **D12/196, 184, D12/190**

(56) **References Cited**

U.S. PATENT DOCUMENTS

D286,867 S	*	11/1986	Envall et al.	D12/184
D317,586 S	*	6/1991	Yoshinao et al.	D12/184
5,238,268 A	*	8/1993	Logan	280/848
5,340,154 A	*	8/1994	Scott	280/848
5,697,644 A	*	12/1997	Logan et al.	280/848
D431,509 S	*	10/2000	Lund	D12/190
D482,995 S	*	12/2003	Saleen	D12/196
D483,312 S	*	12/2003	Saleen	D12/196

* cited by examiner

Primary Examiner—Melody N. Brown
(74) *Attorney, Agent, or Firm*—Crowell & Moring LLP

(57) **CLAIM**

The ornamental design for a surface configuration of trim for a wheel well for a vehicle, as shown and described.

DESCRIPTION

This application is related to co-pending Application Ser. No. 29/180,269, of the inventor, entitled "Surface Configuration of a Vehicle, Toy and/or Other Replicas".

FIG. 1 is a front view of a first embodiment of a surface configuration of trim for a wheel well for a vehicle according to my novel design;

FIG. 2 is a left perspective view of the first embodiment of the surface configuration of trim for a wheel well for a vehicle according to my novel design;

FIG. 3 is a right perspective view of the first embodiment of the surface configuration of trim for a wheel well for a vehicle according to my novel design;

FIG. 4 is a front view of a second embodiment of the surface configuration of trim for a wheel well for a vehicle according to my novel design;

FIG. 5 is a right perspective view of the second embodiment of the surface configuration of trim for a wheel well for a vehicle according to my novel design; and,

FIG. 6 is a left perspective view of the second embodiment of the surface configuration of trim for a wheel well for a vehicle according to my novel design.

The broken lines are for illustrative purposes only and form no part of the claimed design.

1 Claim, 2 Drawing Sheets

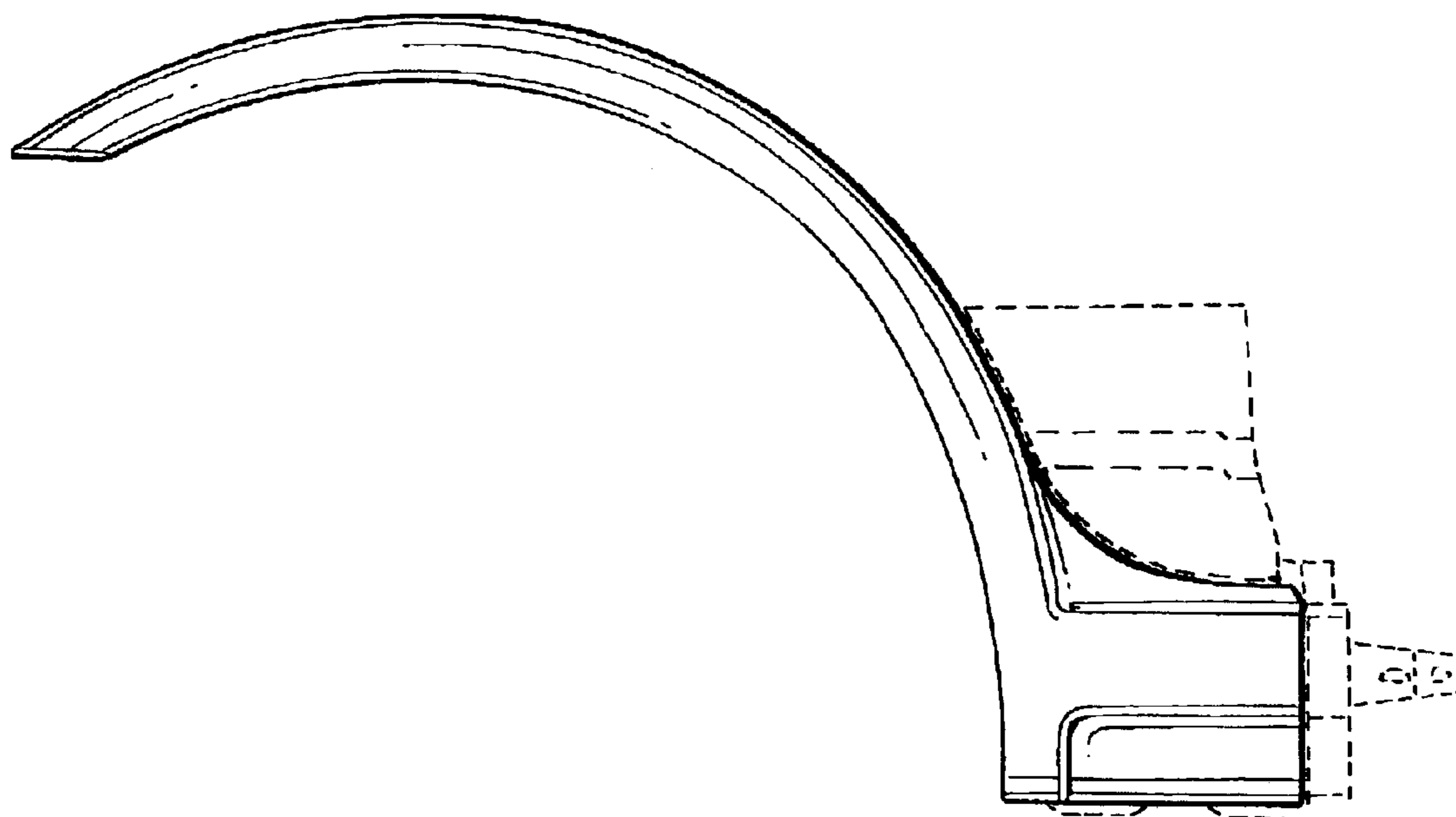

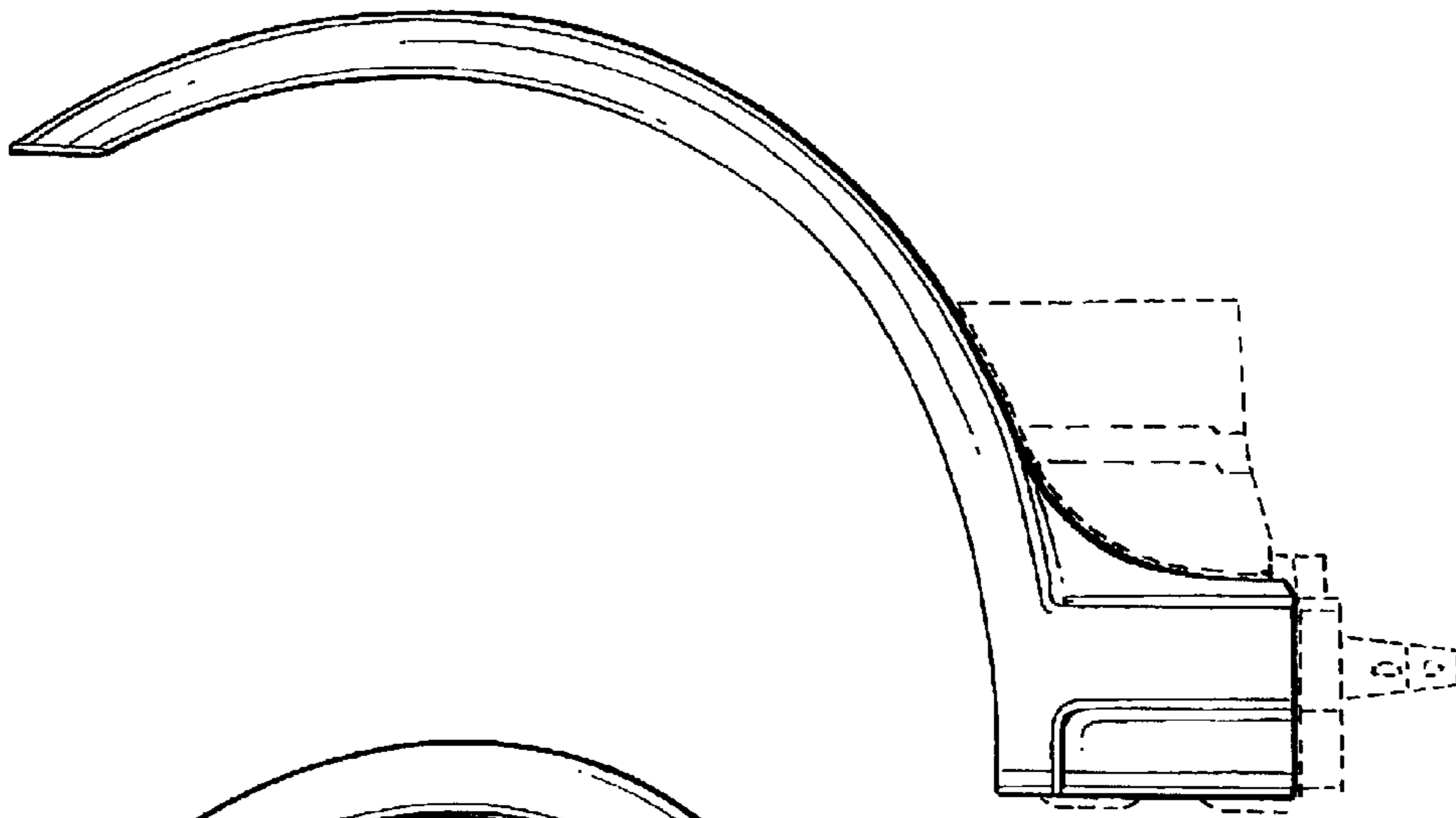

FIG. 1

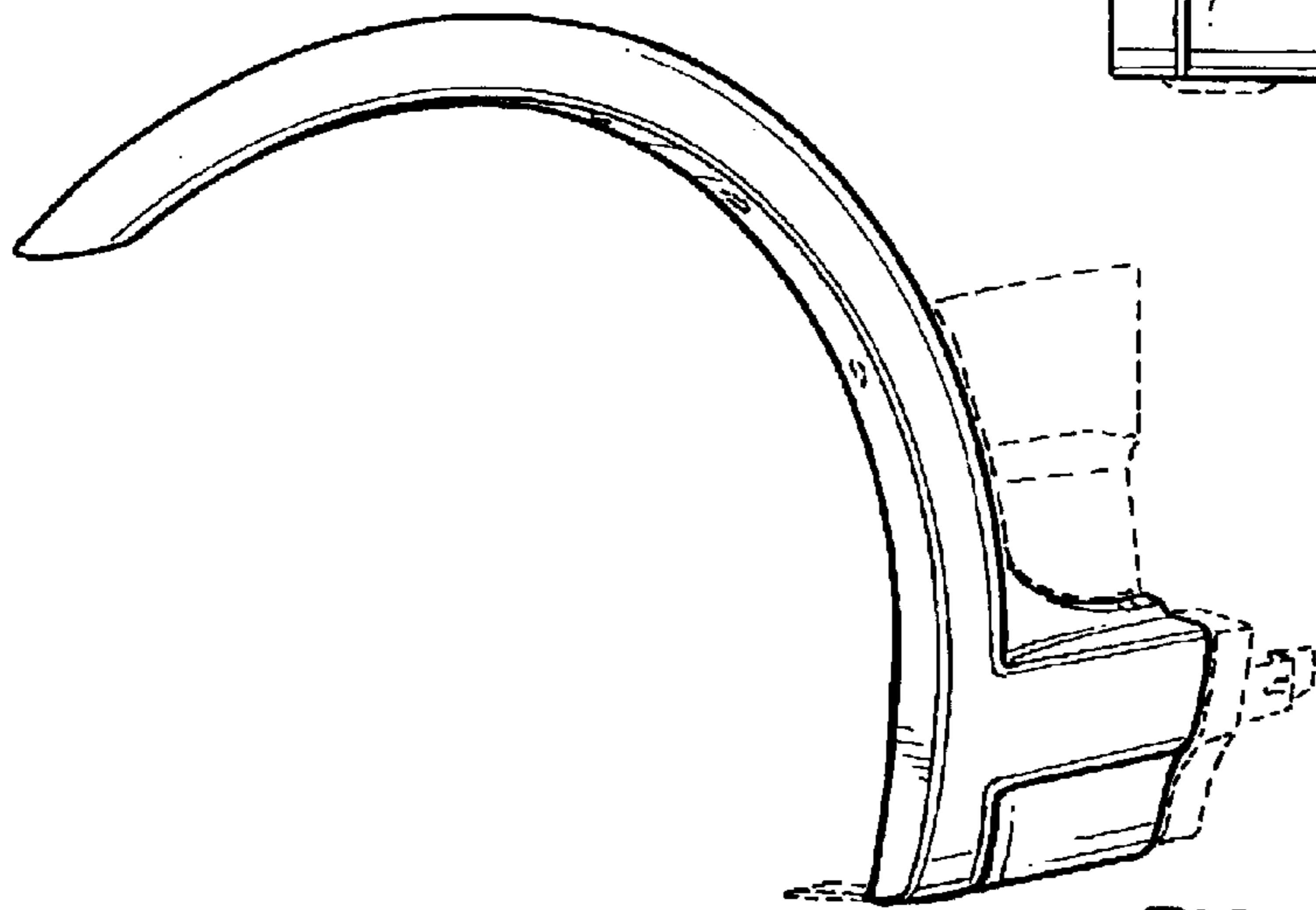

FIG. 2

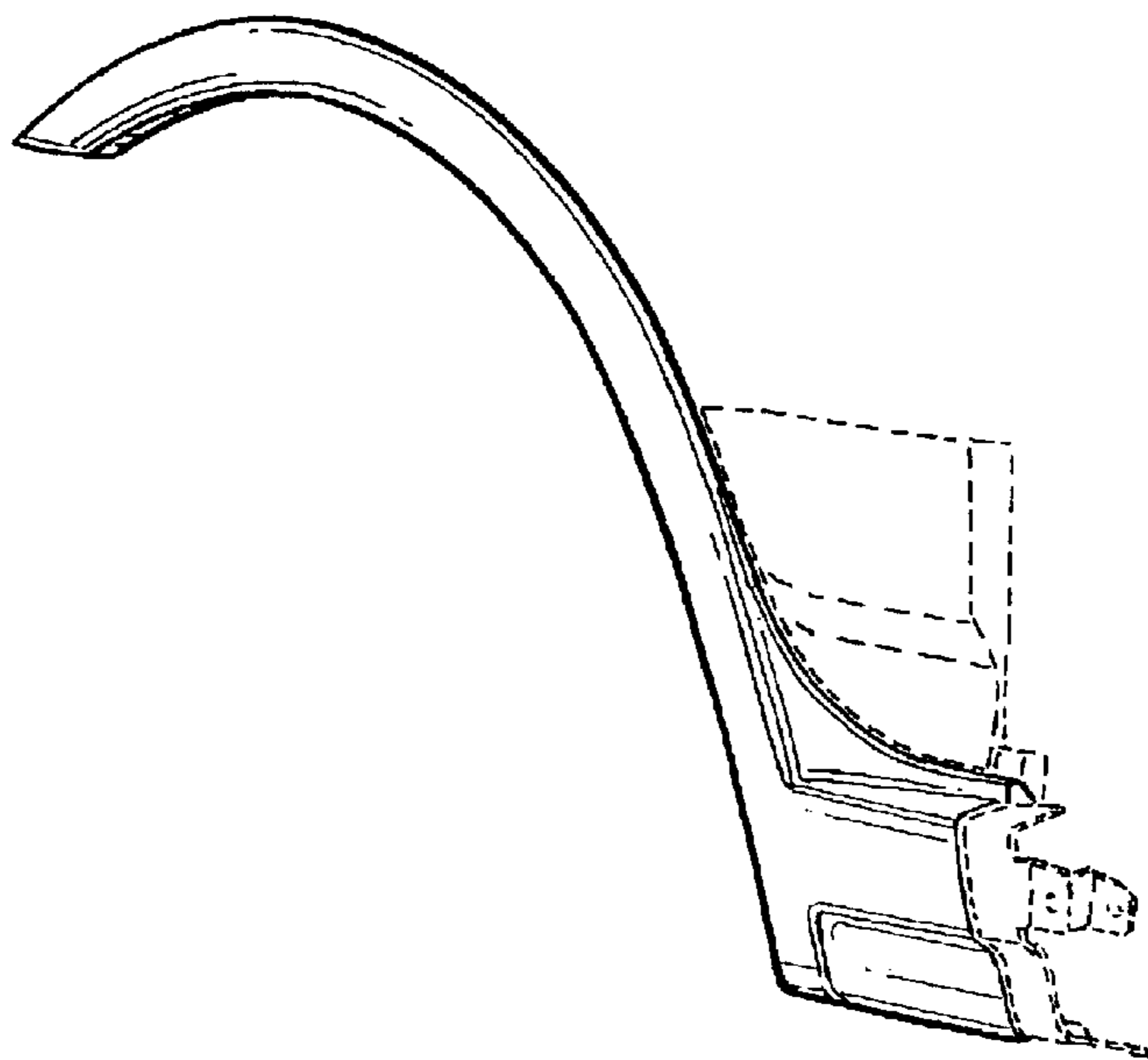

FIG. 3

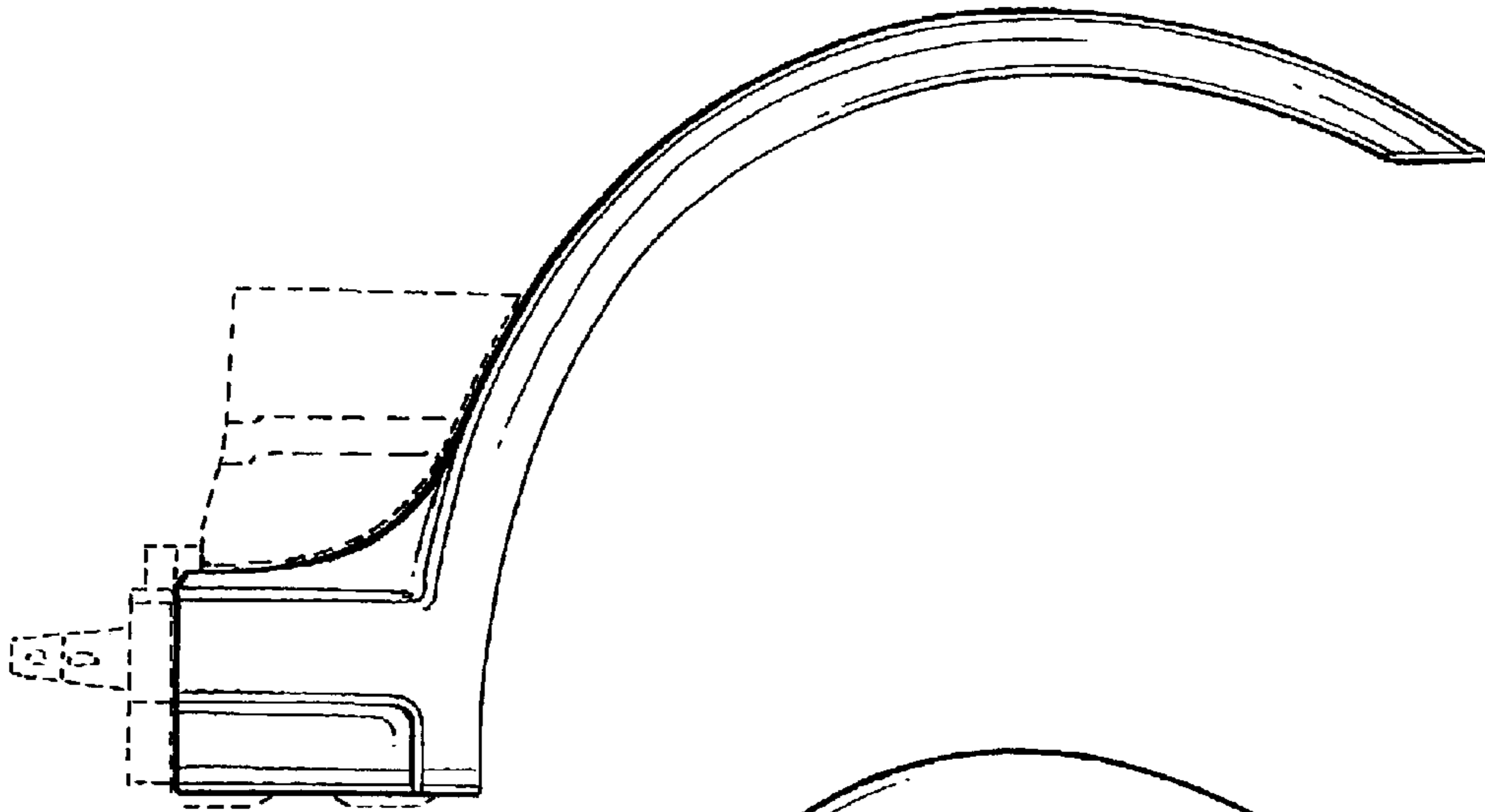

FIG. 4

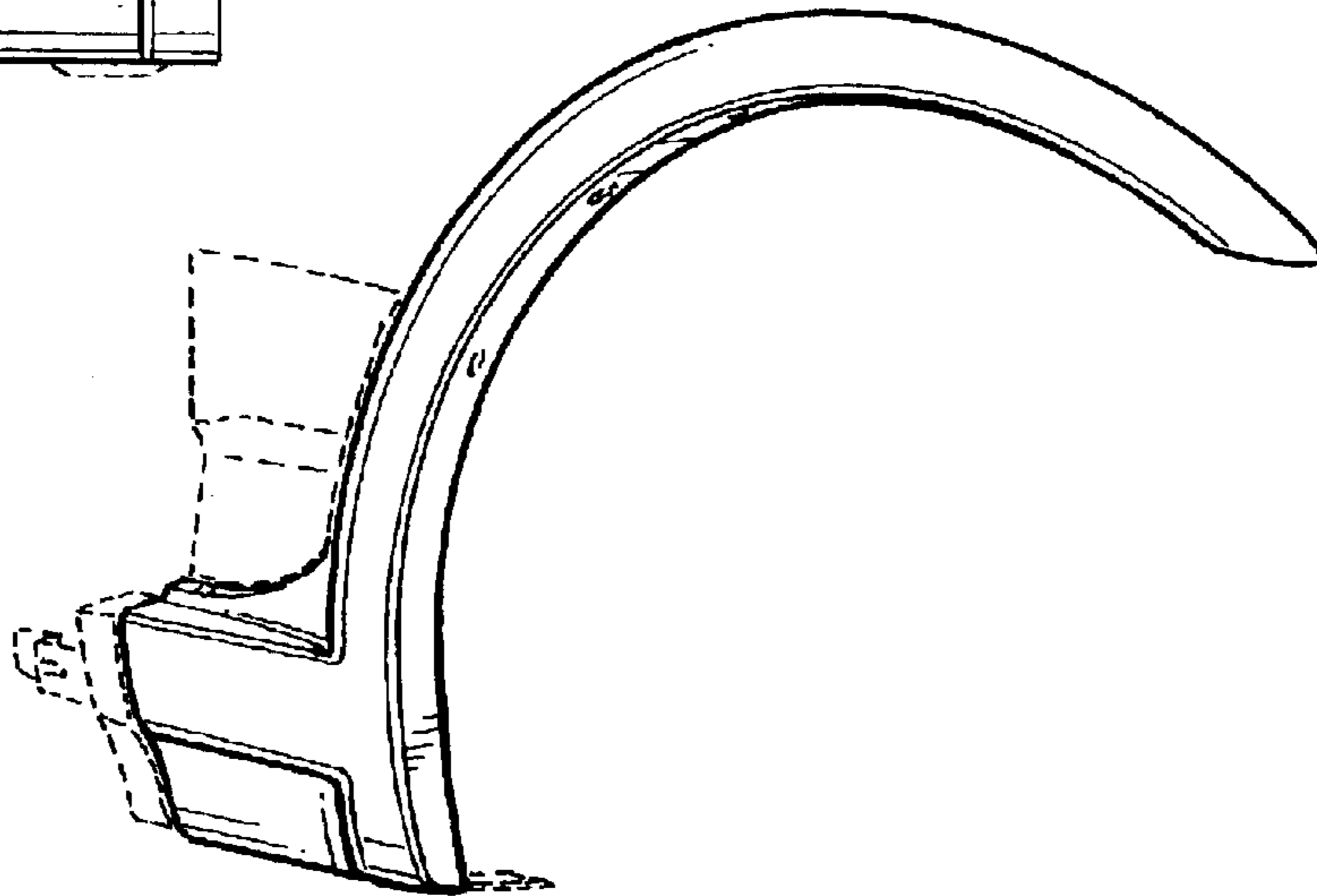

FIG. 5

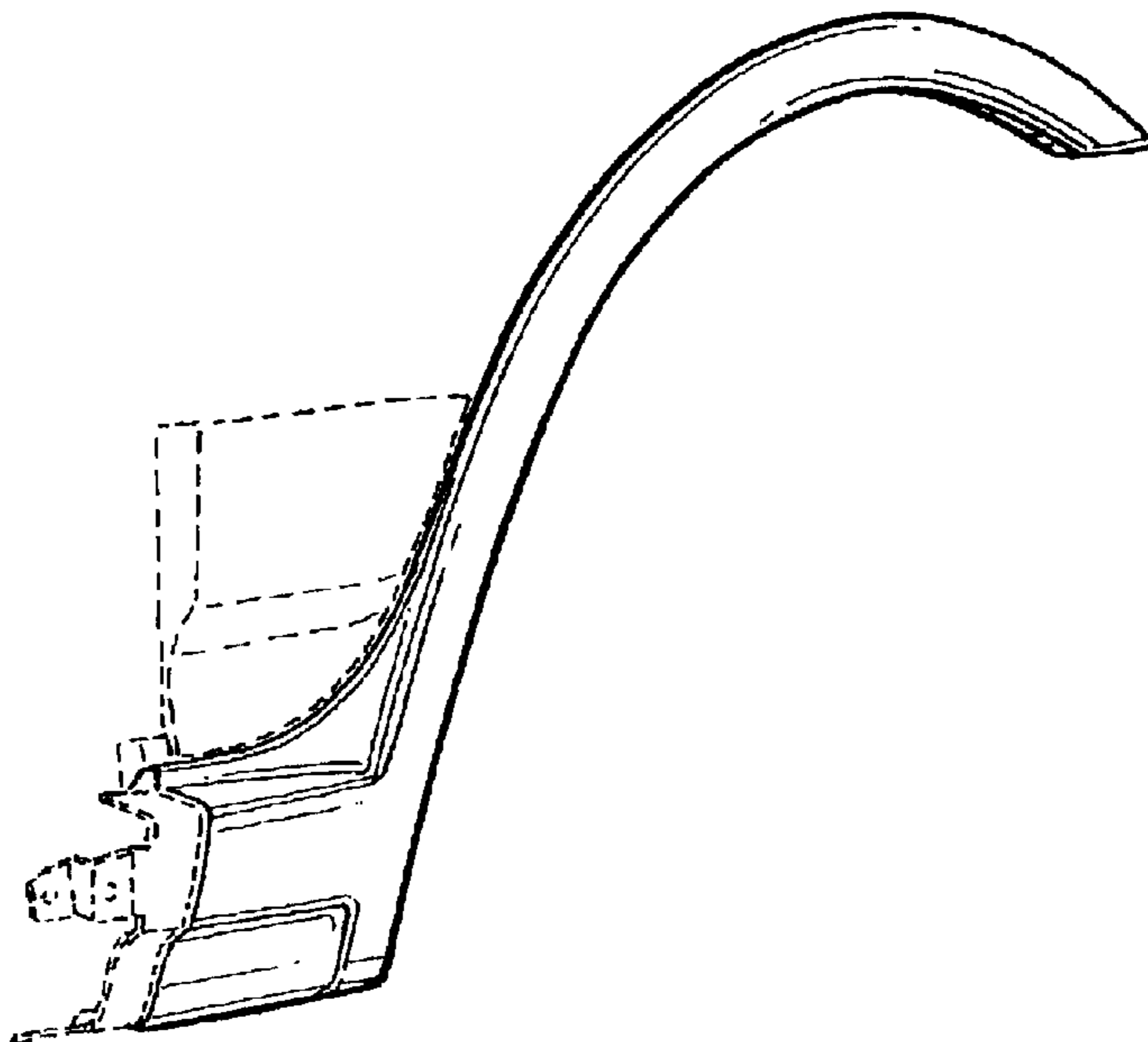

FIG. 6