



US00D491676S

(12) **United States Design Patent**
Gendron et al.

(10) **Patent No.:** **US D491,676 S**

(45) **Date of Patent:** **** Jun. 15, 2004**

(54) **BUILDING BLOCK**

(76) Inventors: **James M. Gendron**, 49964 Fuller Ct.,
Plymouth, MI (US) 48170; **Michael D. Coots**, 3300 Reinhardt, Monroe, MI
(US) 48162

(**) Term: **14 Years**

(21) Appl. No.: **29/172,620**

(22) Filed: **Dec. 13, 2002**

(51) **LOC (7) Cl.** **25-01**

(52) **U.S. Cl.** **D25/118**

(58) **Field of Search** D25/113-118;
D21/484-485, 490, 493, 500-503; 405/16,
284; 52/102, 503, 574, 596-612; 404/34,
40-42

(56) **References Cited**

U.S. PATENT DOCUMENTS

D316,904 S	*	5/1991	Forsberg	D25/114
D369,417 S	*	4/1996	Evans	D25/118
D387,432 S	*	12/1997	Youssefian	D25/114
D463,866 S	*	10/2002	Jang	D25/113
D464,441 S	*	10/2002	Luaces	D25/114

FOREIGN PATENT DOCUMENTS

EP 0055987 * 1/1982 D25/114 X

OTHER PUBLICATIONS

VPB Architectural Products showing a split faced, pitched face masonry unit used in the River's Edge Building project, Traverse City, MI. Aug. 2001; web page: www.vanpoppenbros.com/projects.*

Sheldon Good & Company Realtors brochure showing sale of River's Edge residences, Traverse City, MI, first viewing date Aug. 18, 2001; web site www.sheldongood.com/river-side.*

Van Poppelen Bros.; 1 page various block designs; Undated; Bay City, Michigan.

* cited by examiner

Primary Examiner—Louis S. Zarfaz
Assistant Examiner—Robert A. Delehanty
(74) *Attorney, Agent, or Firm*—Warn, Burgess & Hoffmann, P.C.

(57) **CLAIM**

The ornamental design for a building block, substantially as shown and described.

DESCRIPTION

FIG. 1 is a perspective view of the building block of the present invention showing the front face having two distinct surfaces;

FIG. 2 is a front plan view of the building block of the present invention;

FIG. 3 is a top plan view of the building block of the present invention;

FIG. 4 is a front, fragmented elevational view of a plurality of building blocks of the present invention shown in alternative positions and stacked together to form a wall.

FIG. 5 is a front plan view further illustrating the building block of FIG. 1 with a score line that delineates the respective surfaces; and,

FIG. 6 is a top plan view of the building block of FIG. 5.

The broken line showing the rear portion of the block as the plurality of blocks shown stacked in alternative positions is for illustrative purposes only and forms no part of the claimed design.

1 Claim, 2 Drawing Sheets

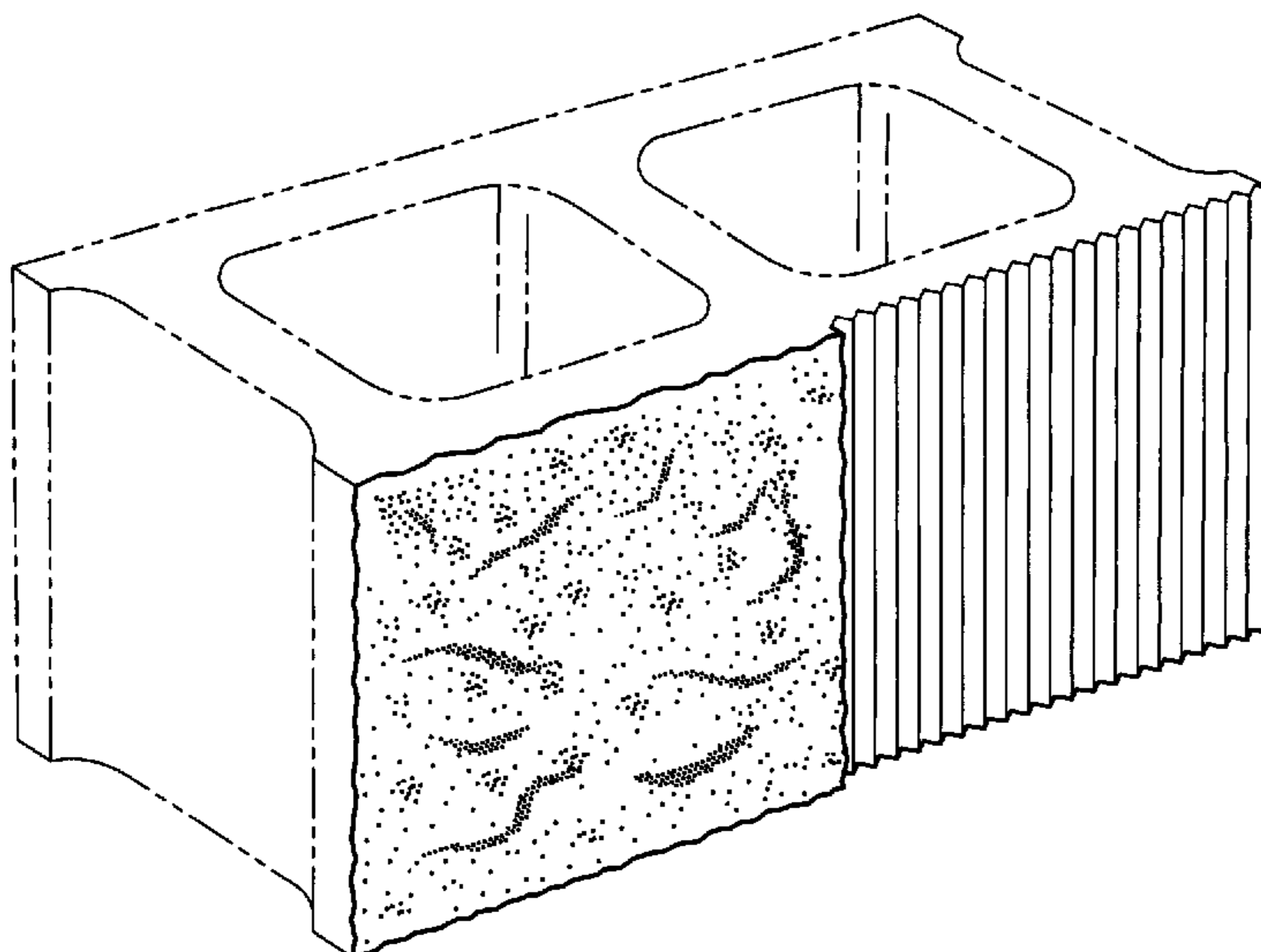

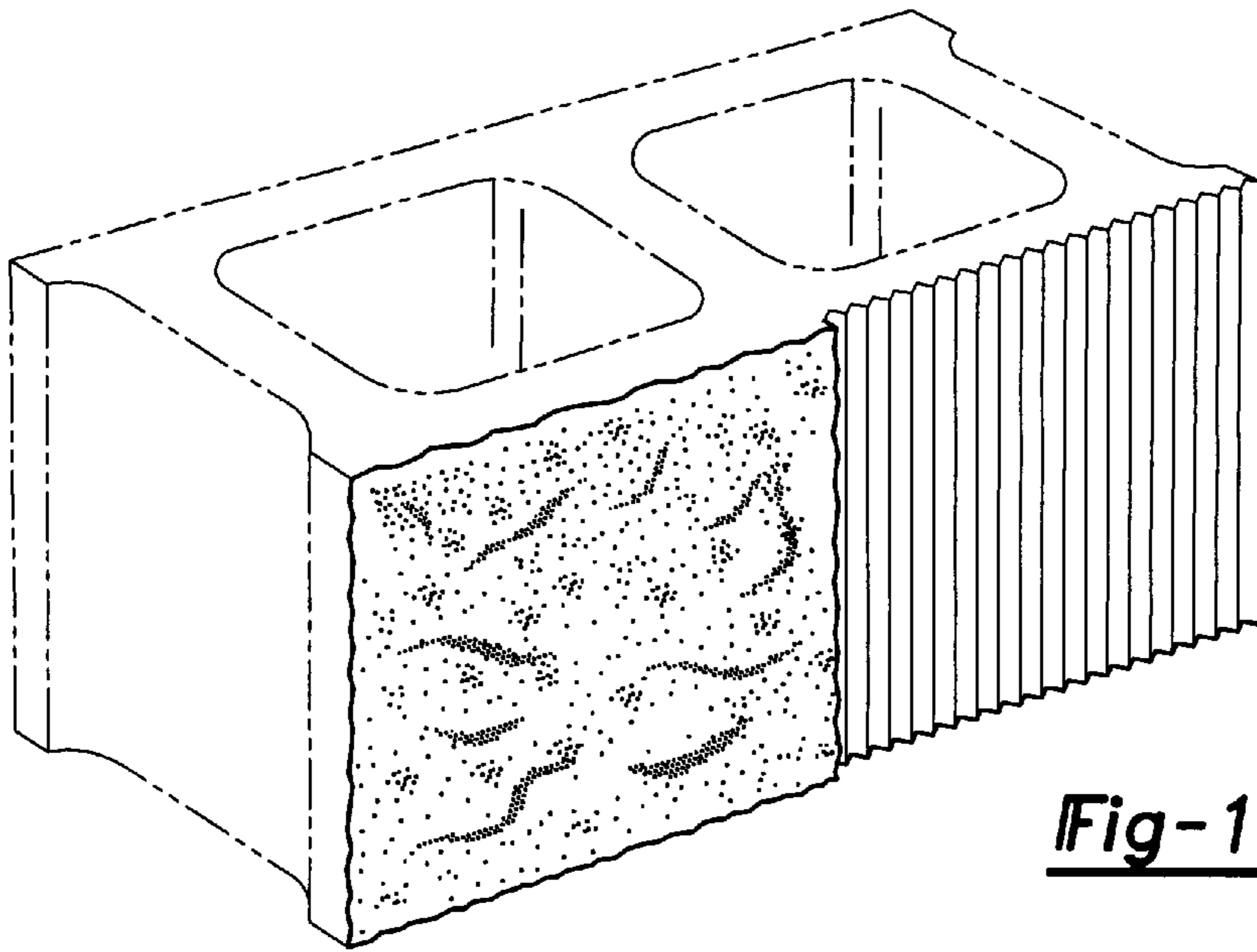

Fig-1

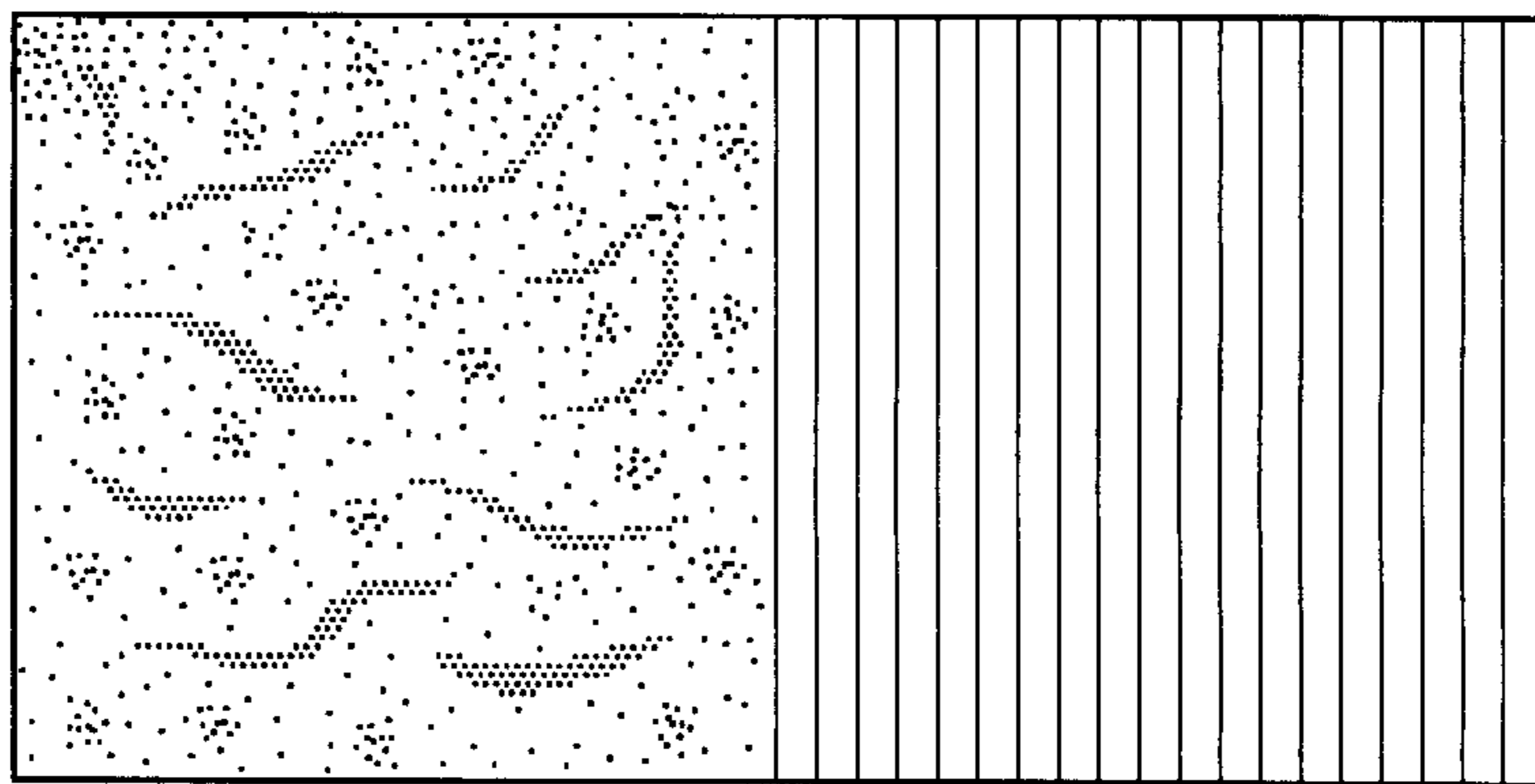

Fig-2

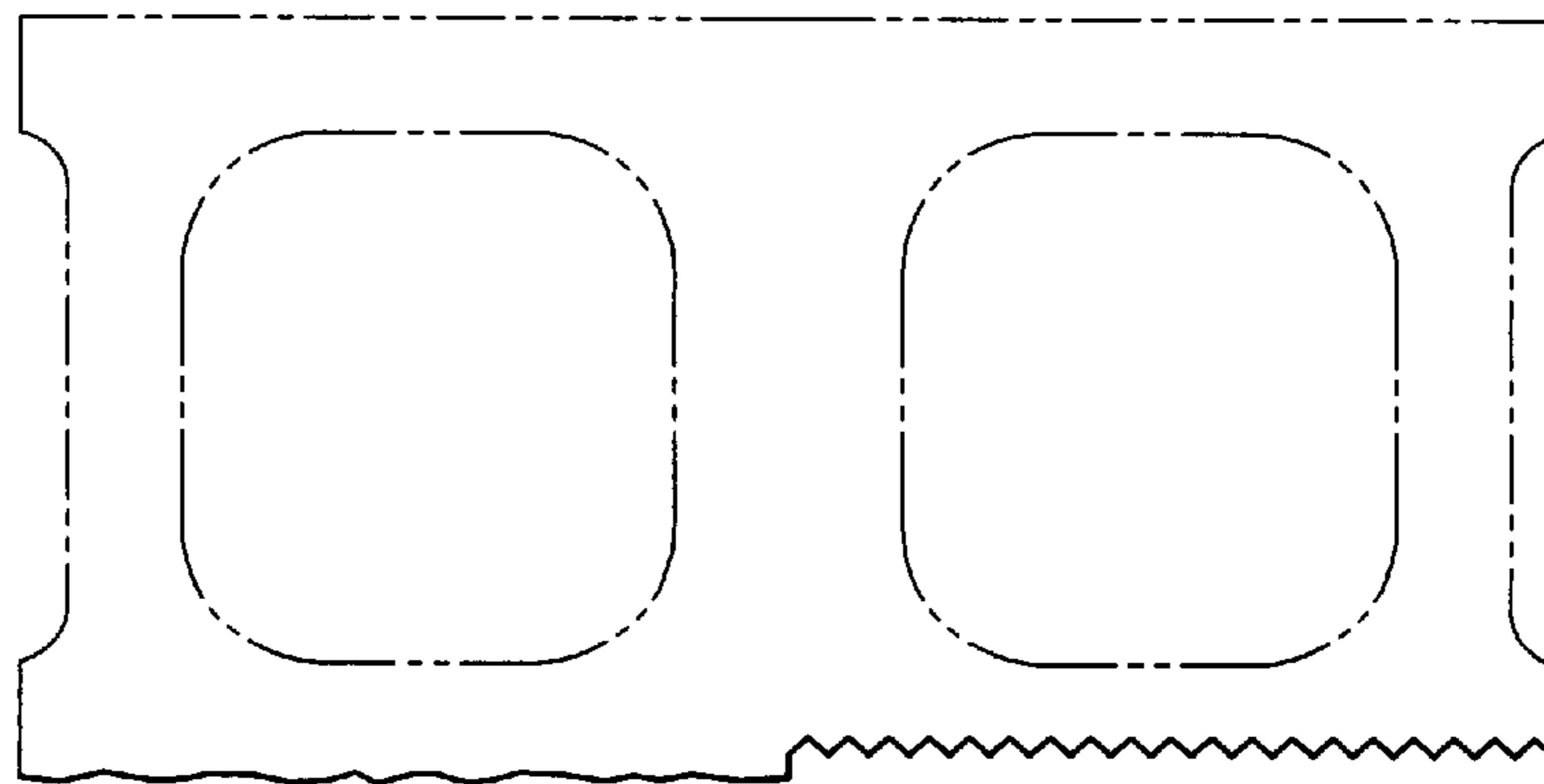

Fig-3

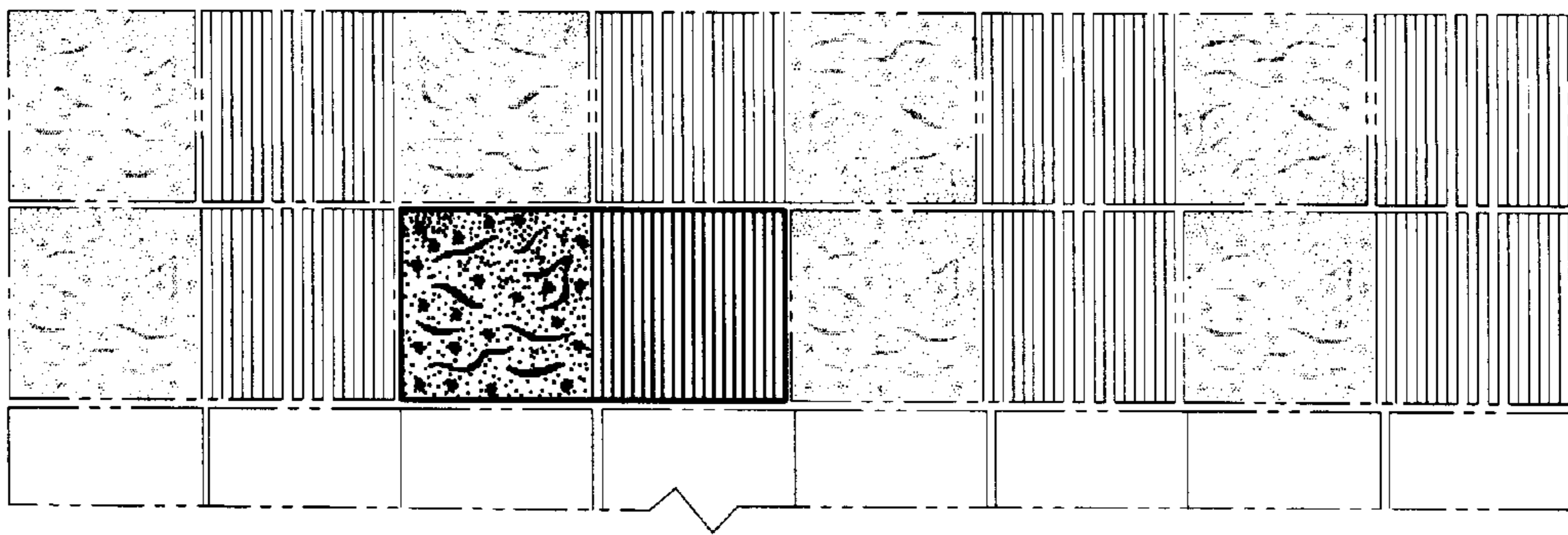

Fig-4

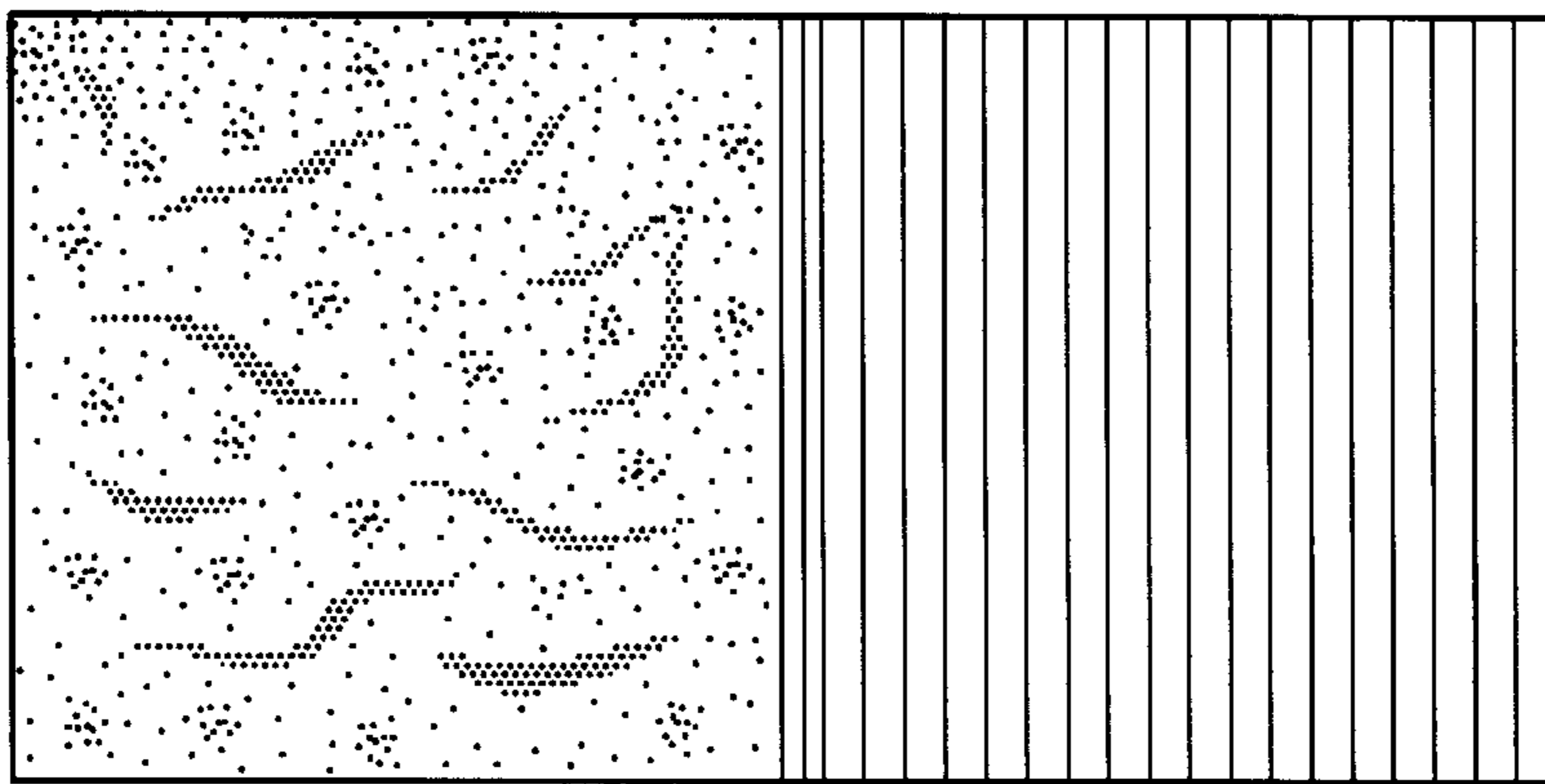

Fig-5

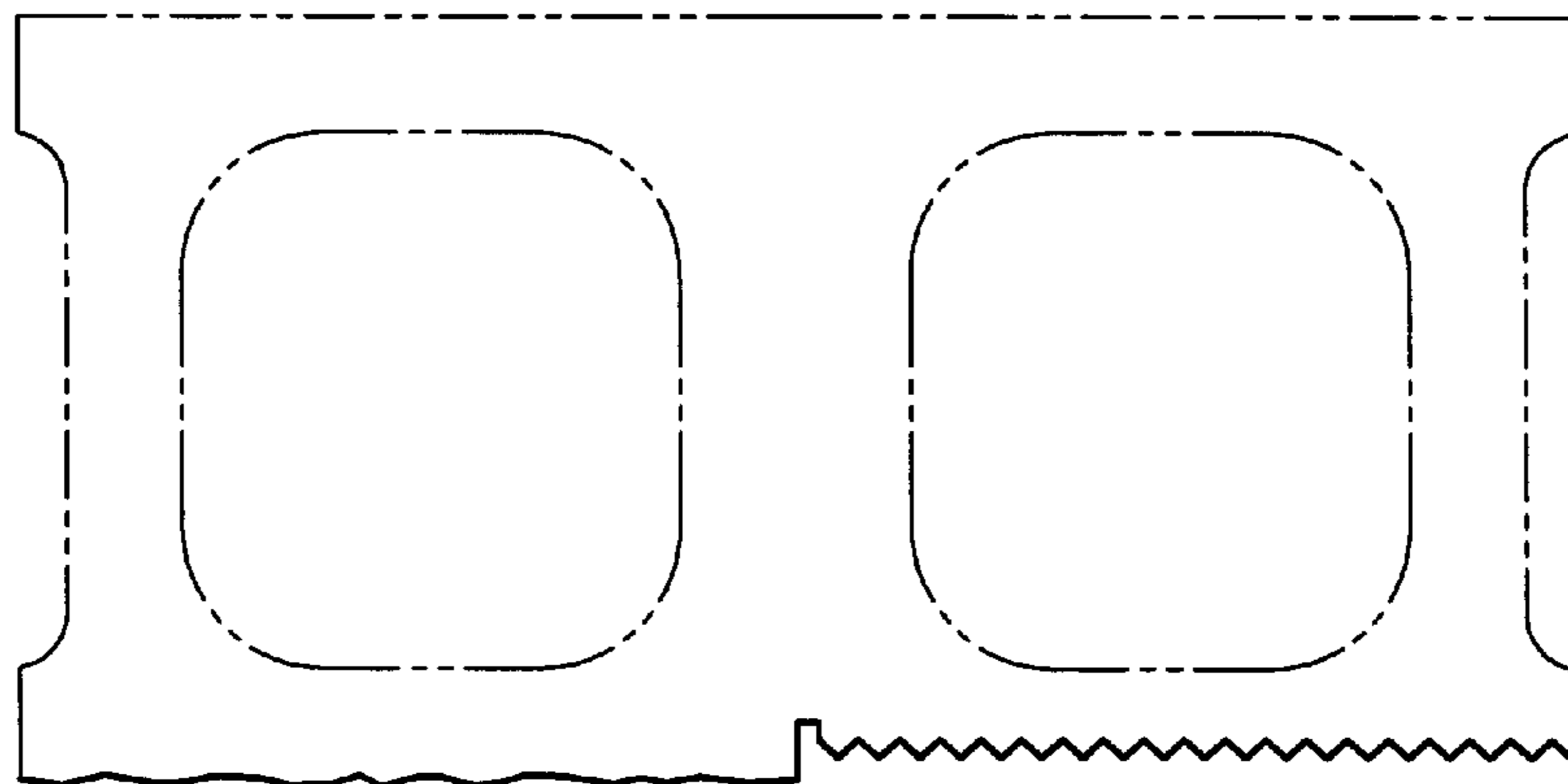

Fig-6