



US00D491491S

(12) **United States Design Patent**
Luh

(10) **Patent No.:** **US D491,491 S**

(45) **Date of Patent:** **** Jun. 15, 2004**

(54) **SAND MOTORCYCLE**

(75) Inventor: **Tai-Yang Luh**, Tai Ping (TW)

(73) Assignee: **Taiwan Power Industrial Co., Ltd.**,
Tai Ping (TW)

(**) Term: **14 Years**

(21) Appl. No.: **29/182,016**

(22) Filed: **May 19, 2003**

(51) **LOC (7) Cl.** **12-11**

(52) **U.S. Cl.** **D12/107**

(58) **Field of Search** D12/87, 107; 180/225,
180/229, 233, 311, 312, 315

(56) **References Cited**

U.S. PATENT DOCUMENTS

D445,363 S * 7/2001 Luh D12/107

D446,475 S * 8/2001 Luh D12/107

* cited by examiner

Primary Examiner—Alan P. Douglas

Assistant Examiner—Linda Brooks

(74) *Attorney, Agent, or Firm*—Alan D. Kamrath; Rider
Bennett, LLP

(57) **CLAIM**

The ornamental design for a sand motorcycle, as shown and
described.

DESCRIPTION

FIG. 1 is a front elevational view of a sand motorcycle
showing my design;

FIG. 2 is a rear elevational view thereof;

FIG. 3 is a left side elevational view thereof;

FIG. 4 is a right side elevational view thereof;

FIG. 5 is a top plan view thereof;

FIG. 6 is a bottom plan view thereof; and,

FIG. 7 is a perspective view thereof.

1 Claim, 7 Drawing Sheets

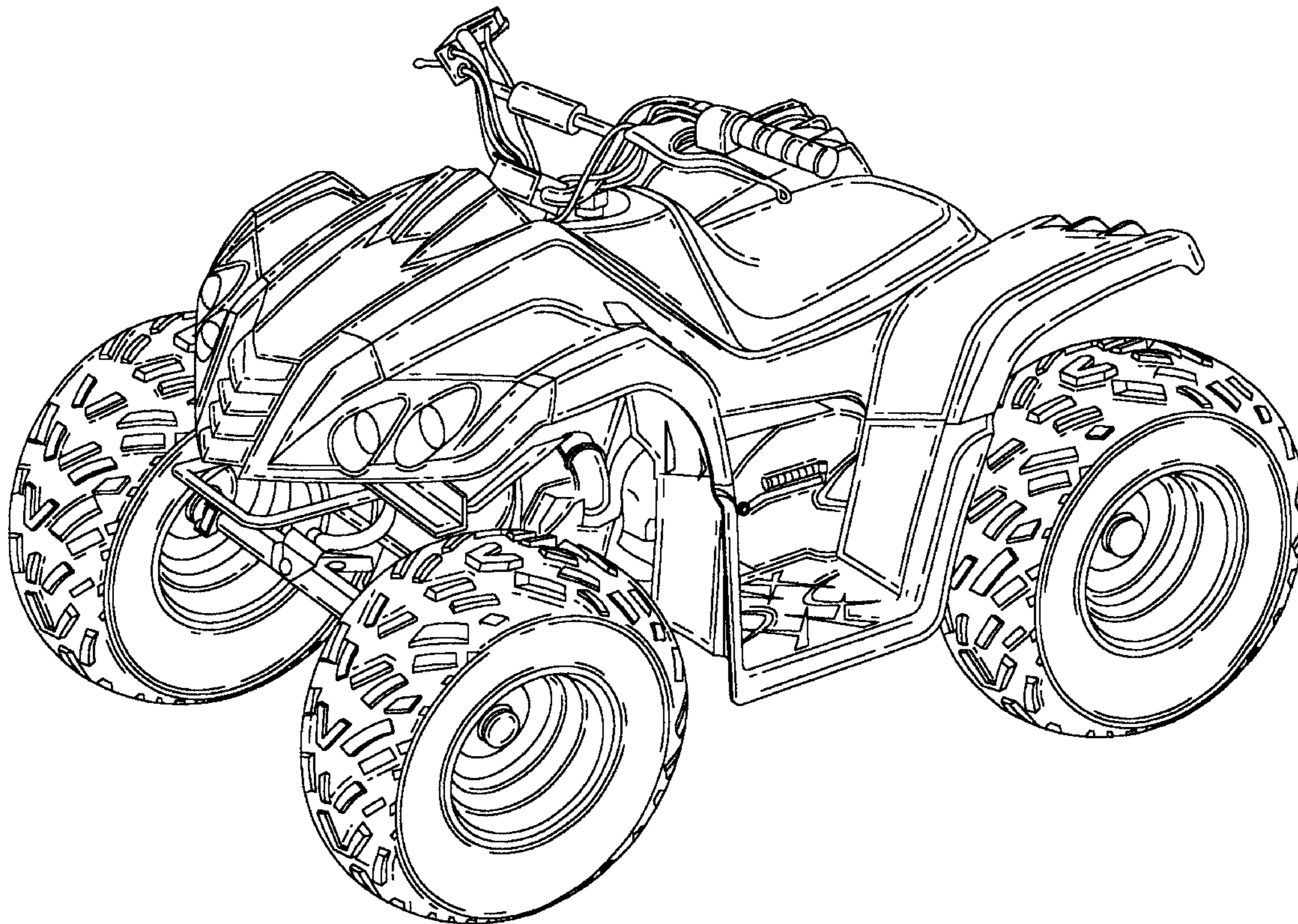

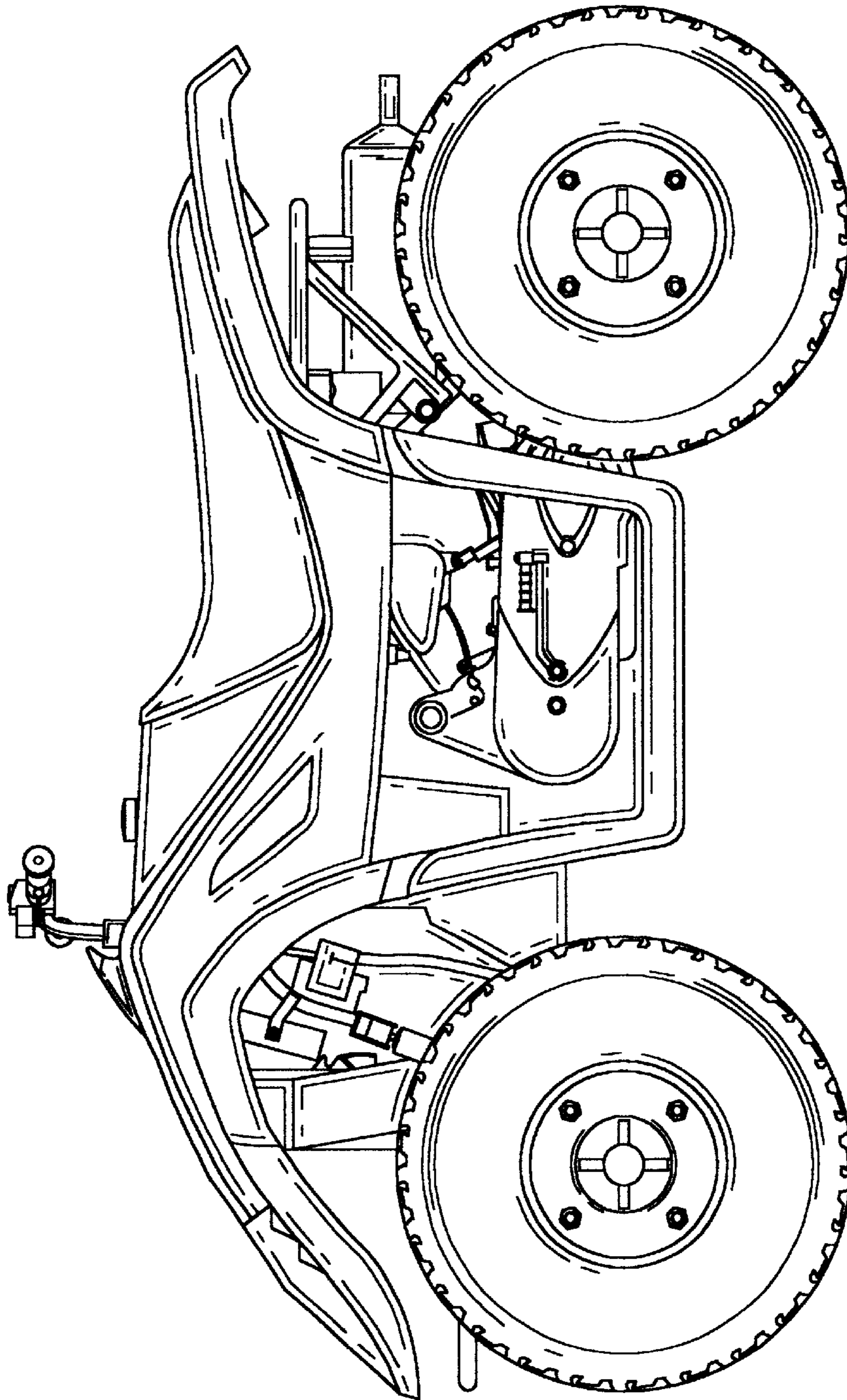

FIG. 1

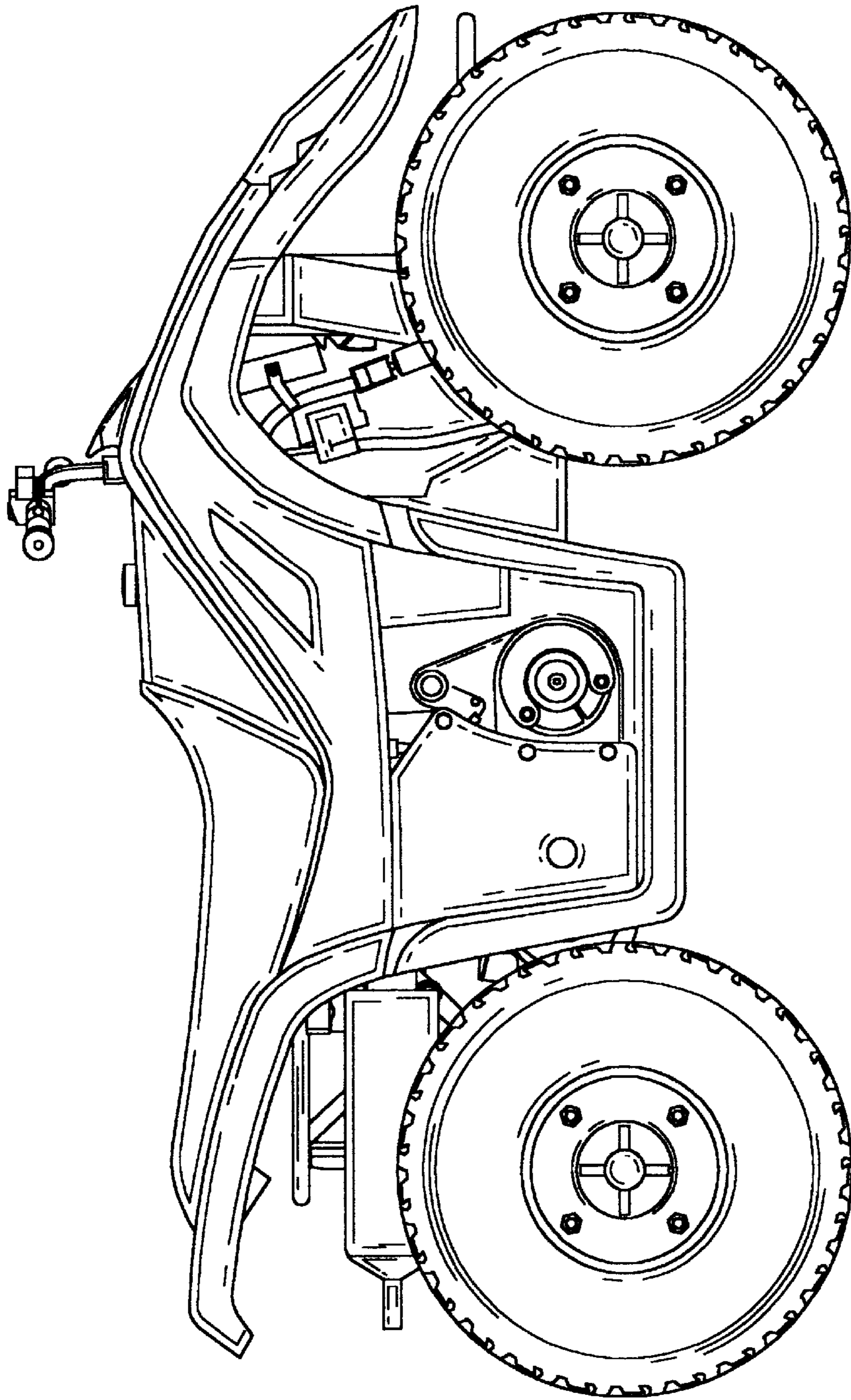

FIG. 2

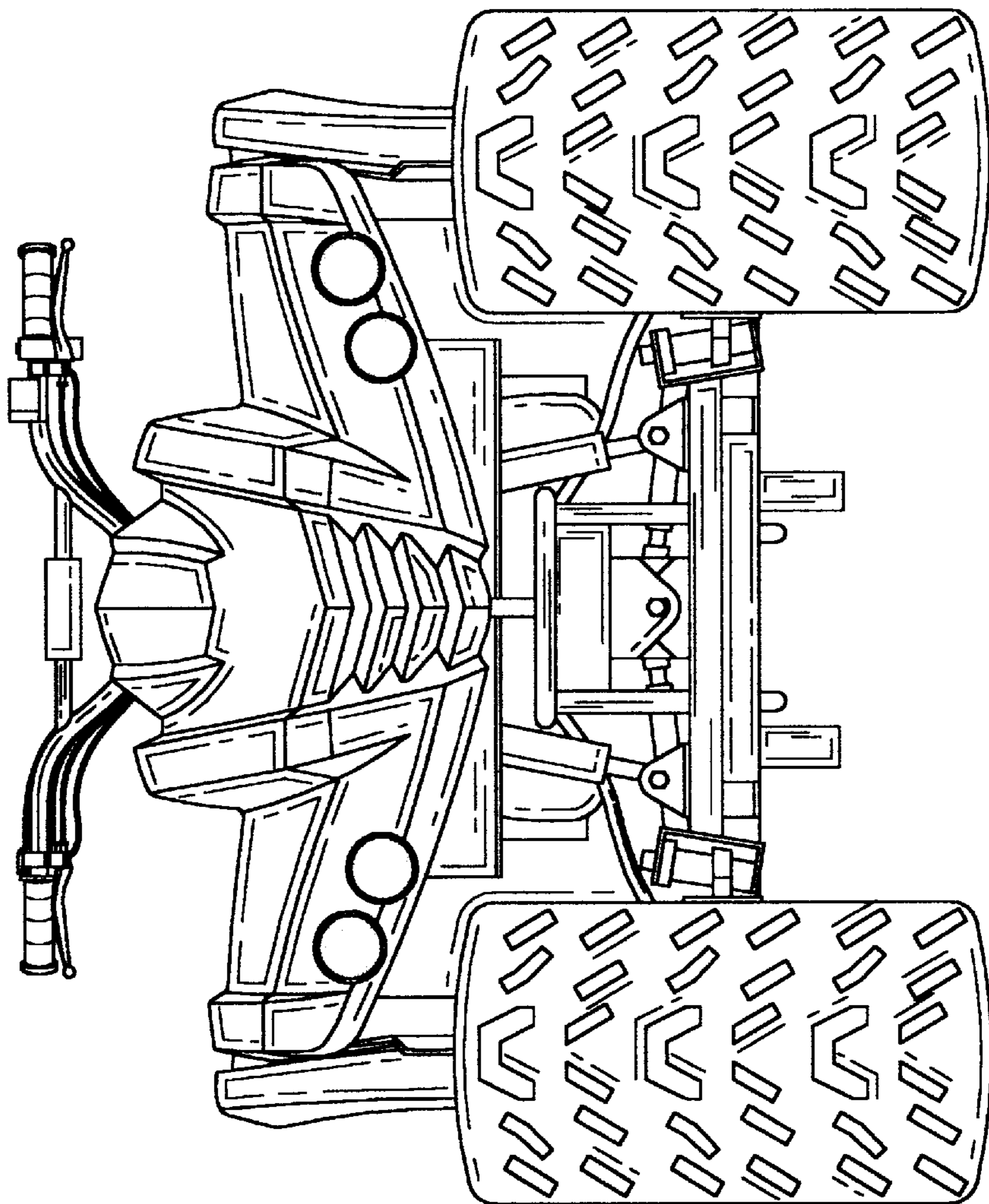

FIG. 3

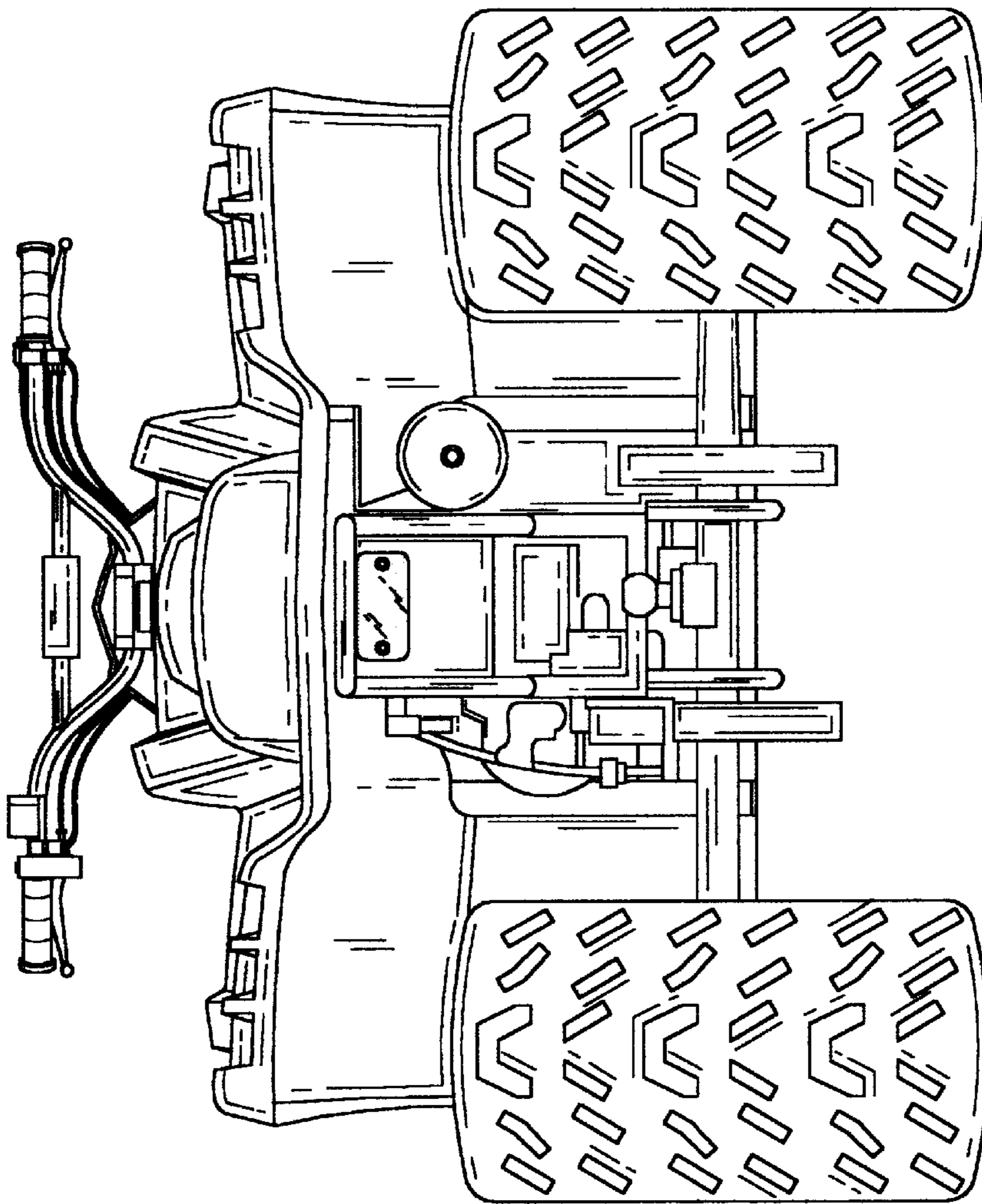

FIG. 4

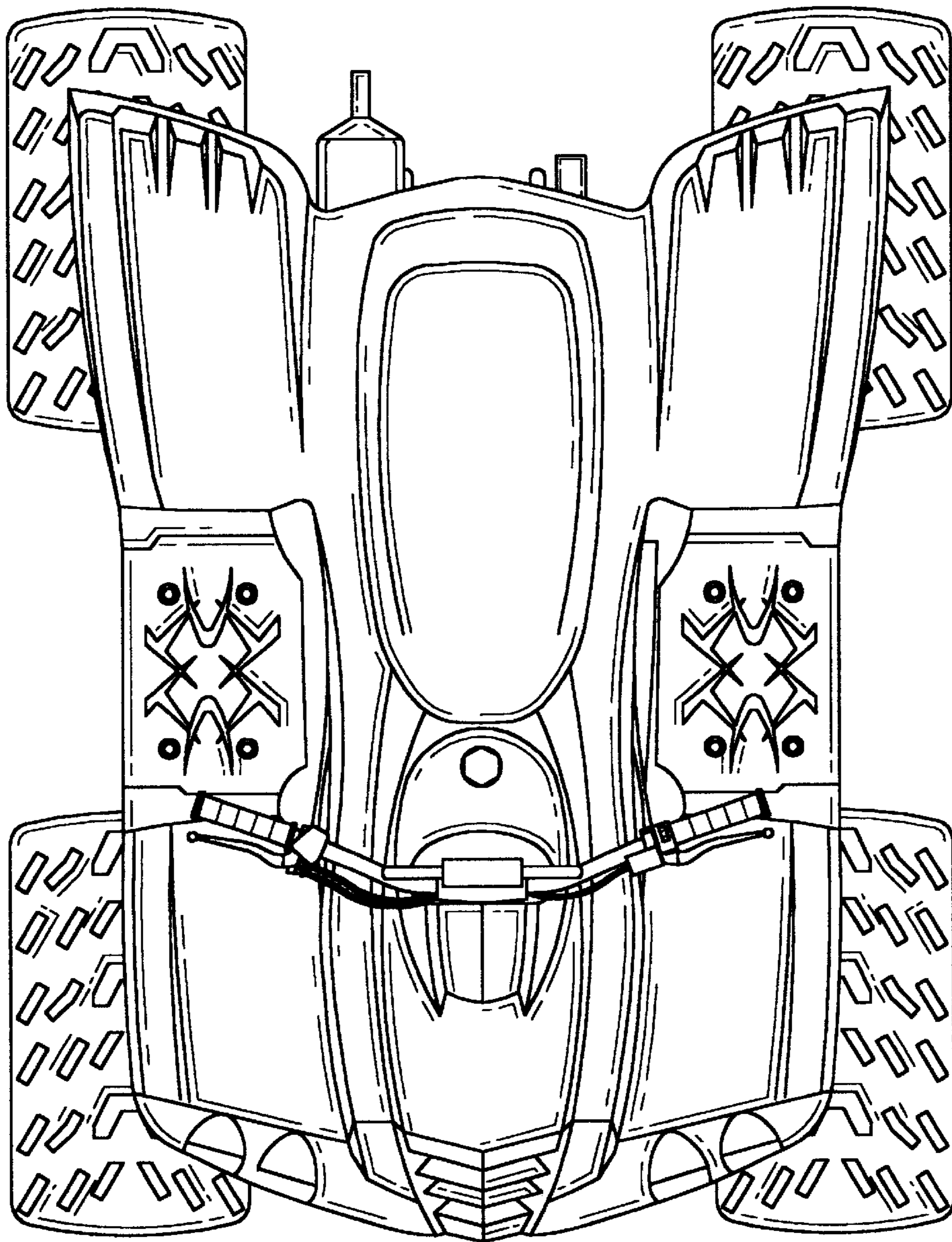

FIG. 5

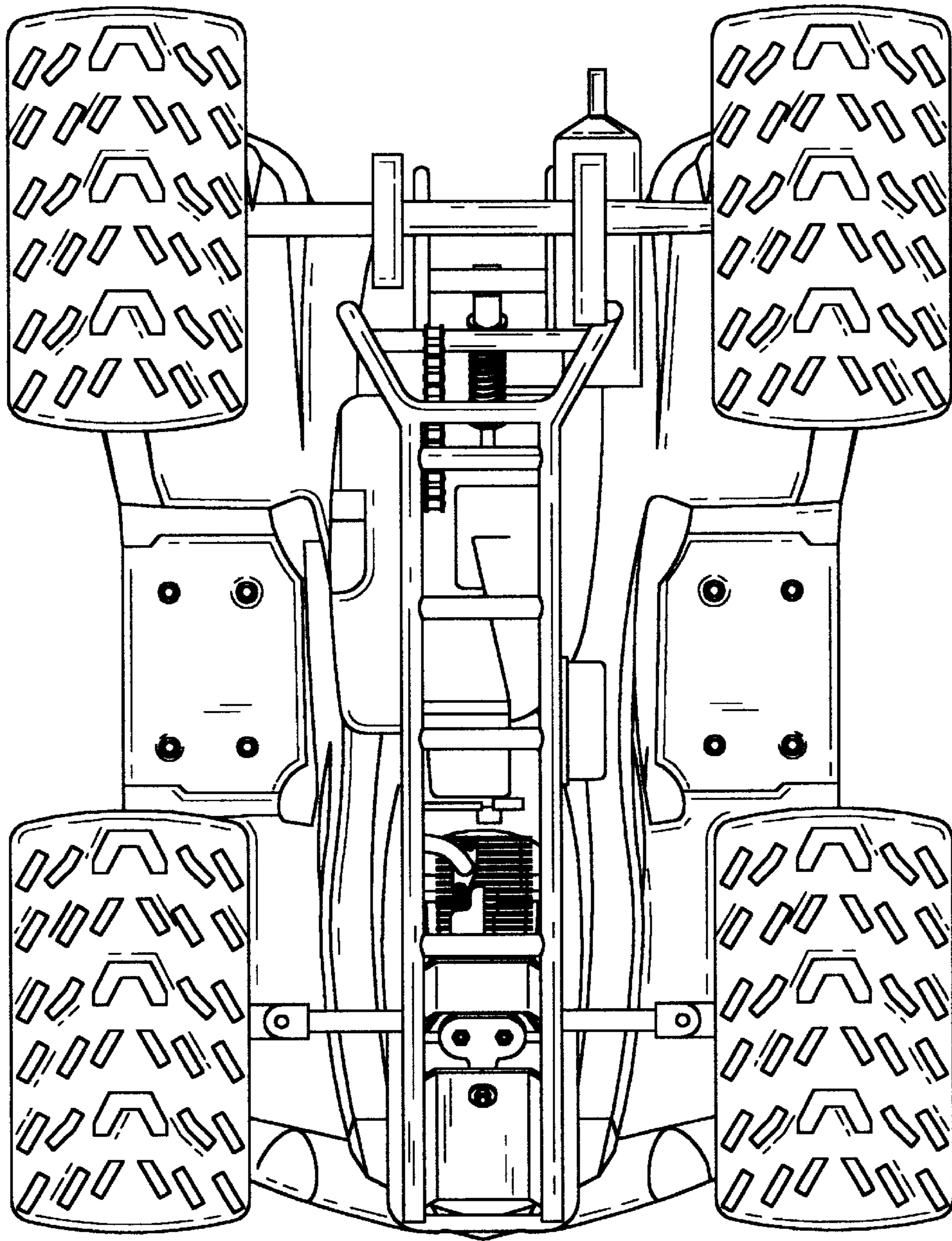

FIG. 6

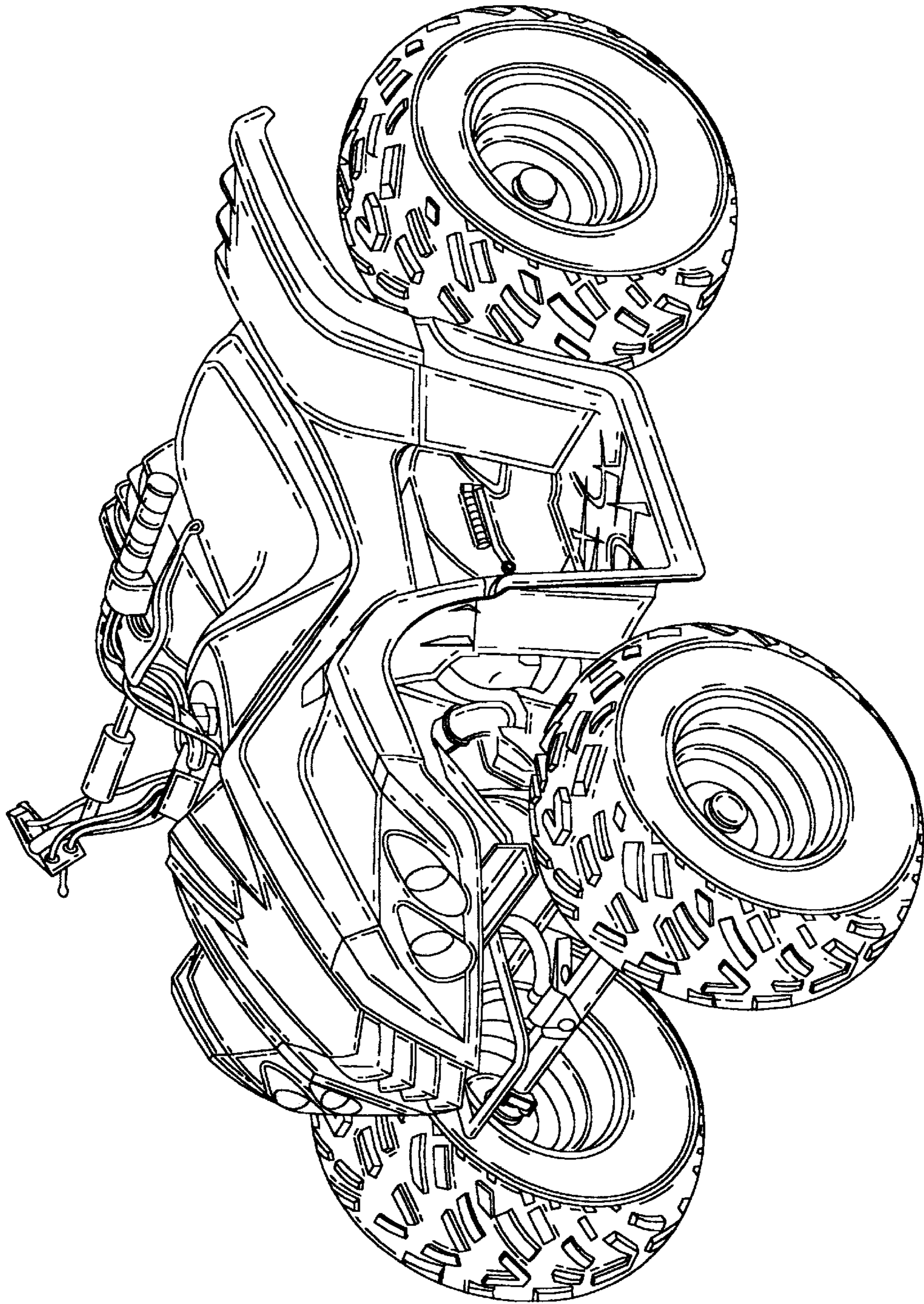

FIG. 7