



US00D491457S

(12) **United States Design Patent**
Fabrice

(10) **Patent No.:** **US D491,457 S**

(45) **Date of Patent:** **** Jun. 15, 2004**

(54) **BOTTLE**

(75) Inventor: **Legros Fabrice**, Asnieres (FR)

(73) Assignee: **Bulgari S.p.A.**, Rome (IT)

(**) Term: **14 Years**

(21) Appl. No.: **29/168,178**

(22) Filed: **Sep. 27, 2002**

(30) **Foreign Application Priority Data**

Apr. 9, 2002 (IT) RM2002O0084

(51) **LOC (7) Cl.** **09-01**

(52) **U.S. Cl.** **D9/332; D9/549**

(58) **Field of Search** D9/307, 332, 339,
D9/500, 503, 516, 521, 544, 545, 549;
D3/202; 206/457, 527; 215/382, 379, 400

(56) **References Cited**

U.S. PATENT DOCUMENTS

- D173,880 S * 1/1955 Olifiers D9/544
- D272,603 S * 2/1984 Dinand D9/544
- D428,213 S * 7/2000 De Baschmakoff D9/544
- D443,979 S * 6/2001 Rijlaarsdam D3/202
- D456,267 S * 4/2002 Borri D9/521

OTHER PUBLICATIONS

“A Collector’s Handbook of Miniature Perfume Bottles” by Jeri Lyn Ringblum, published 1996. p. 203, Paloma Picasso perfume bottle.*

Beauty Fashion magazine, Feb. 1983. p. 35, Monteil Champagne perfume bottle.*

* cited by examiner

Primary Examiner—Sandra L. Morris

(74) *Attorney, Agent, or Firm*—Reising, Ethington, Barnes, Kisselle, P.C.

(57) **CLAIM**

The ornamental design for a bottle, as shown and described.

DESCRIPTION

FIG. 1 is a front view of a bottle showing my new design;
 FIG. 2 is a right side view thereof;
 FIG. 3 is a rear view thereof;
 FIG. 4 is a left side view thereof;
 FIG. 5 is a top view thereof;
 FIG. 6 is a bottom view thereof;
 FIG. 7 is perspective view thereof; and,
 FIG. 8 is a perspective view showing parts thereof in an alternate position.

“The BVLGARI logo is a registered trademark of Bulgari S.p.A”.

1 Claim, 1 Drawing Sheet

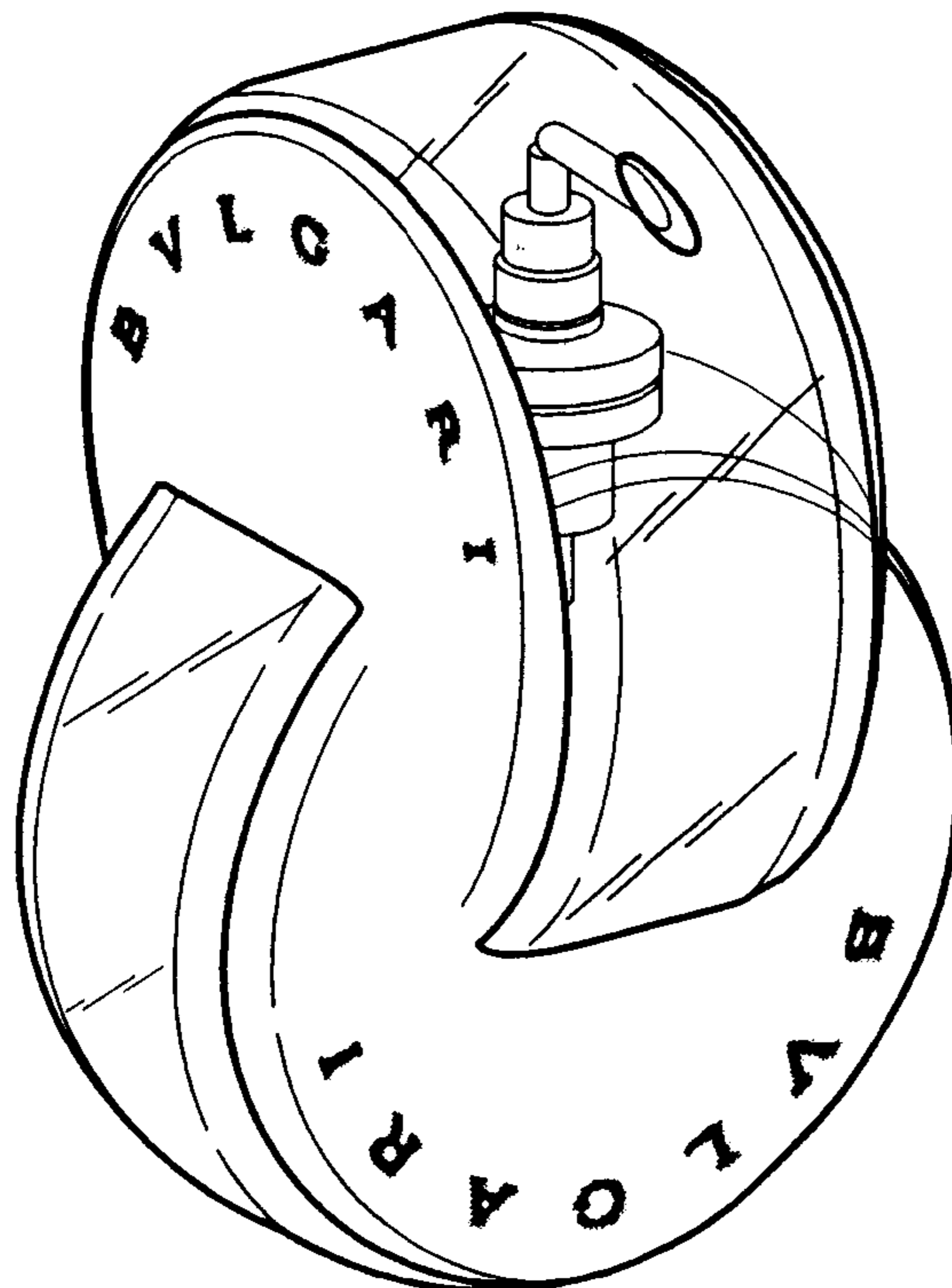

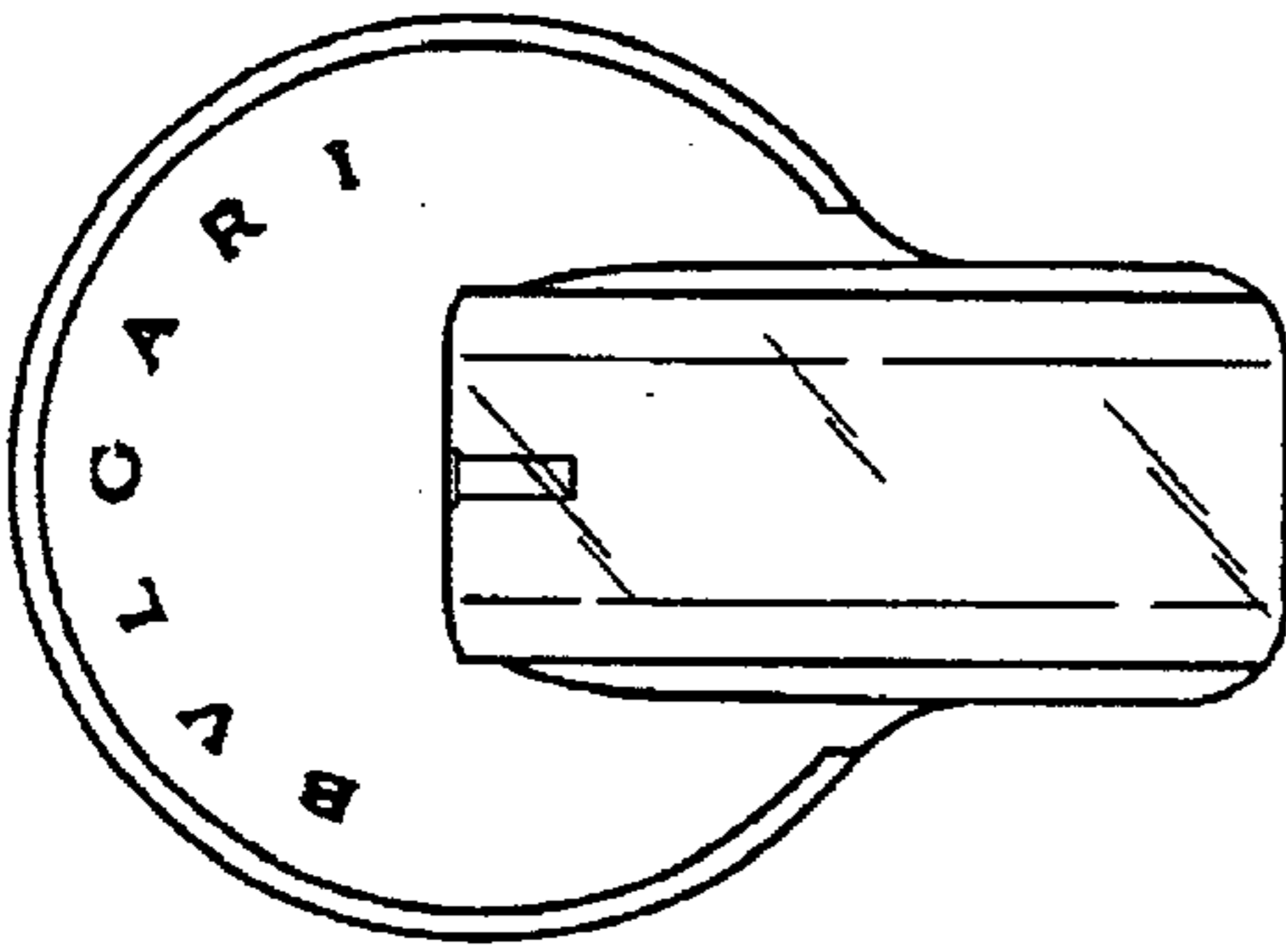

FIG. 1

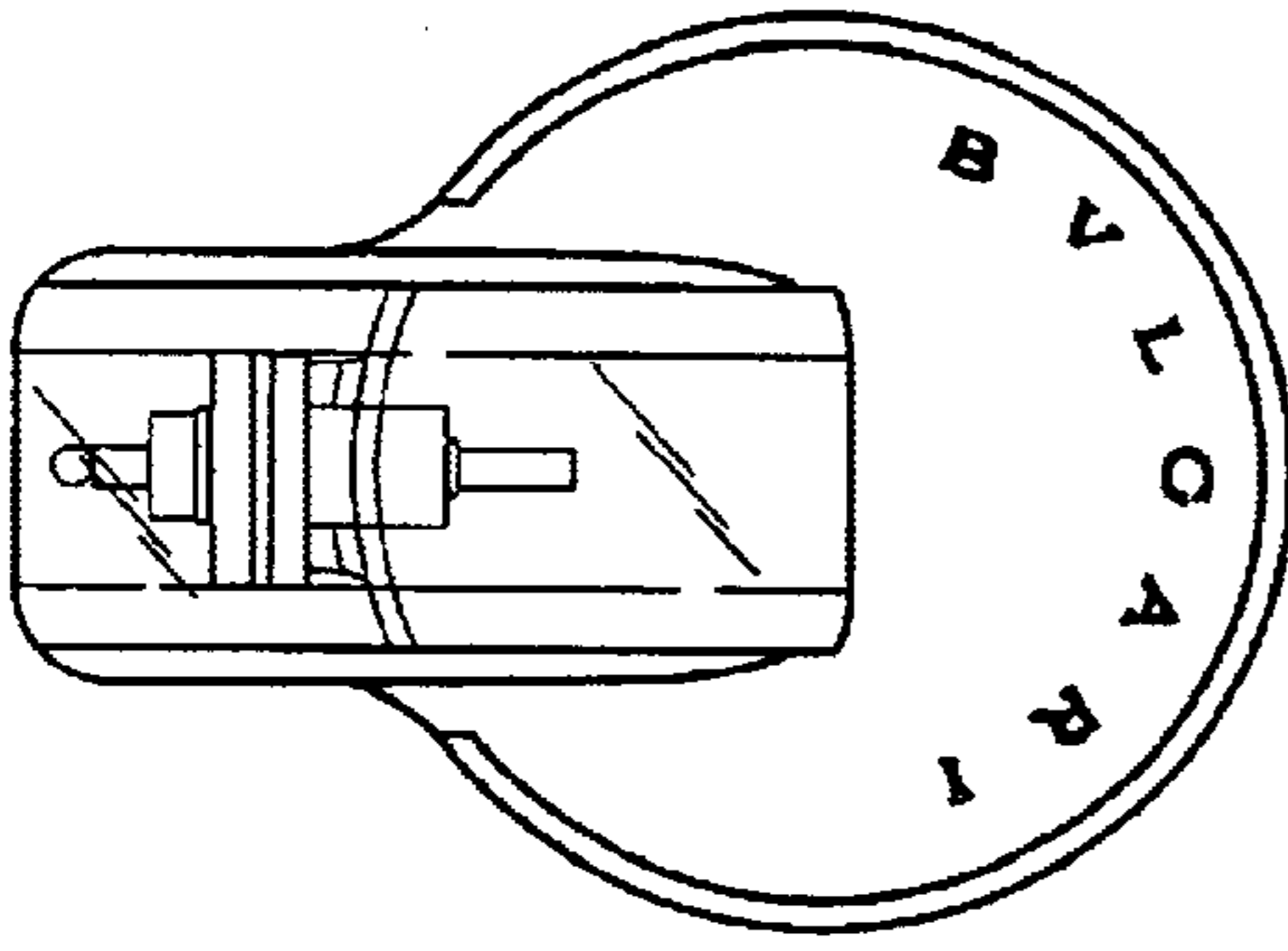

FIG. 2

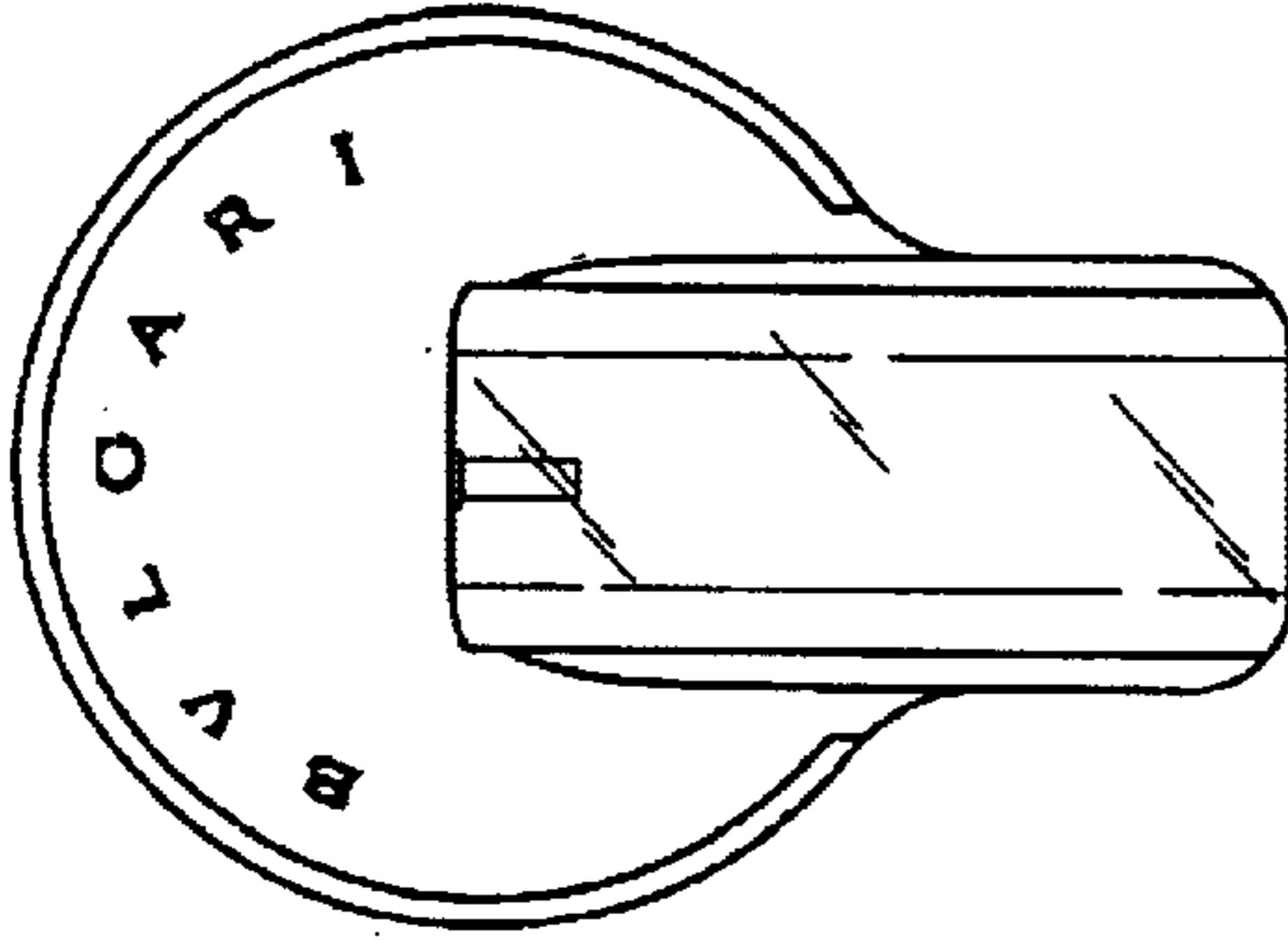

FIG. 3

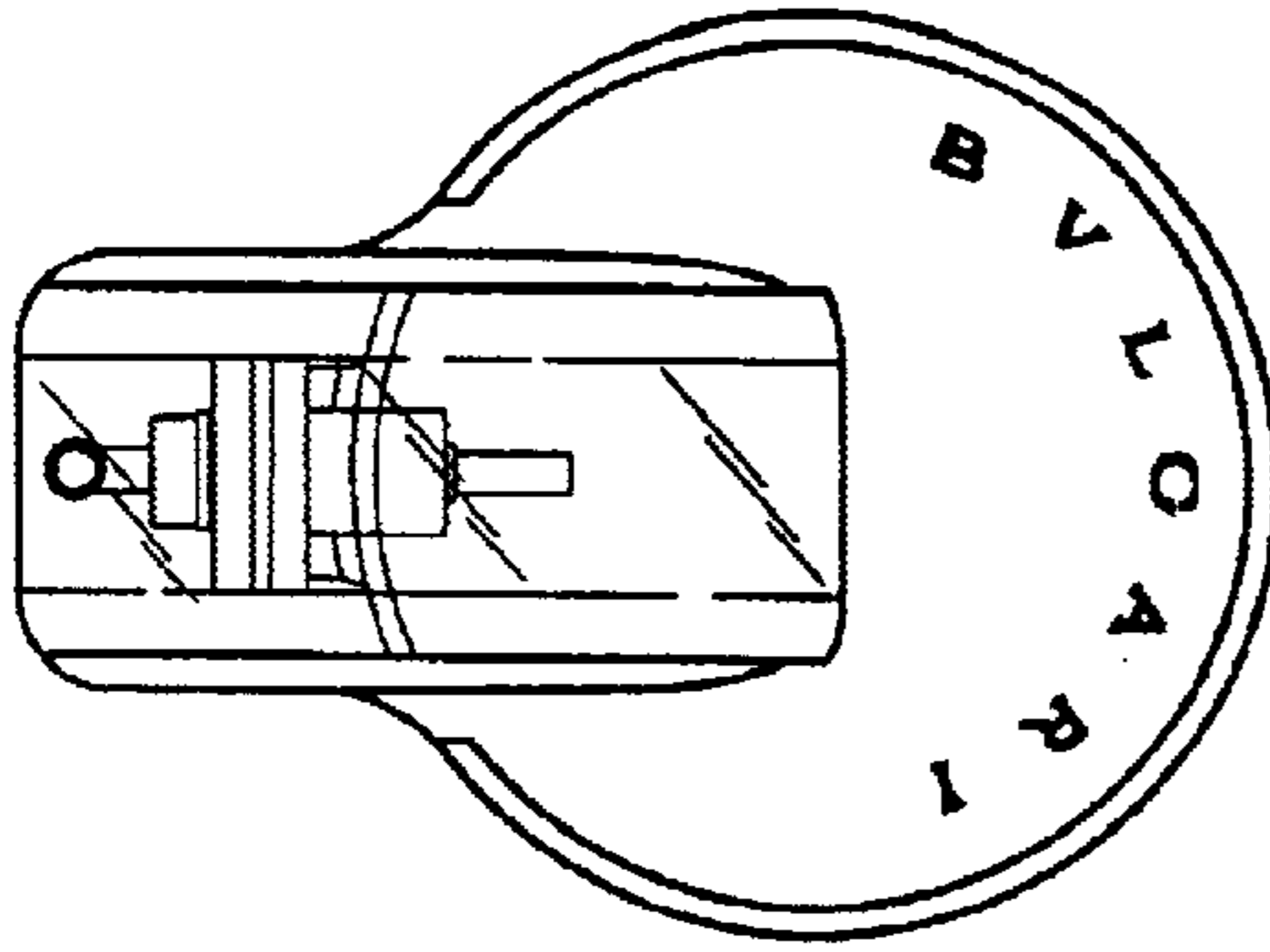

FIG. 4

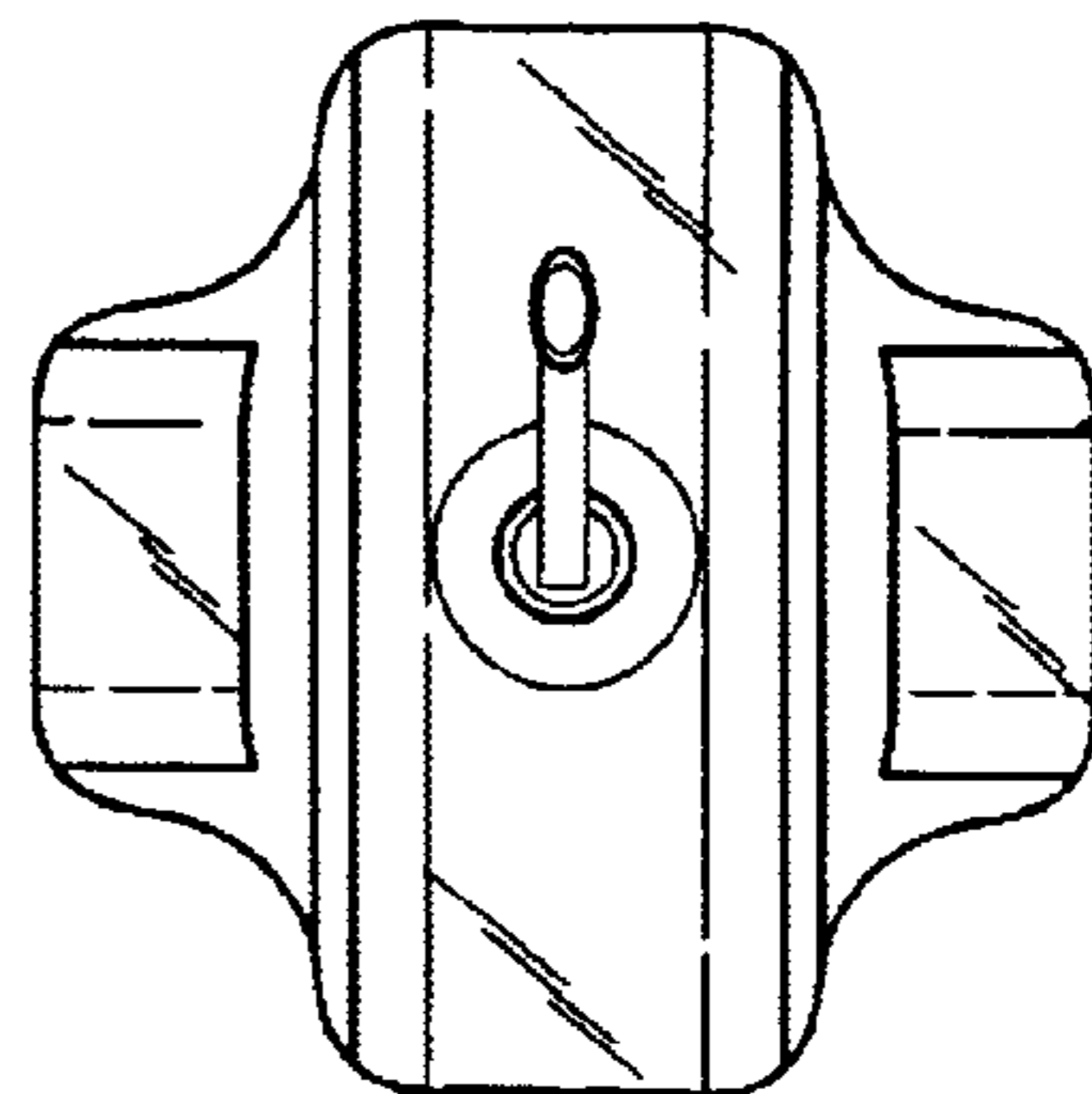

FIG. 5

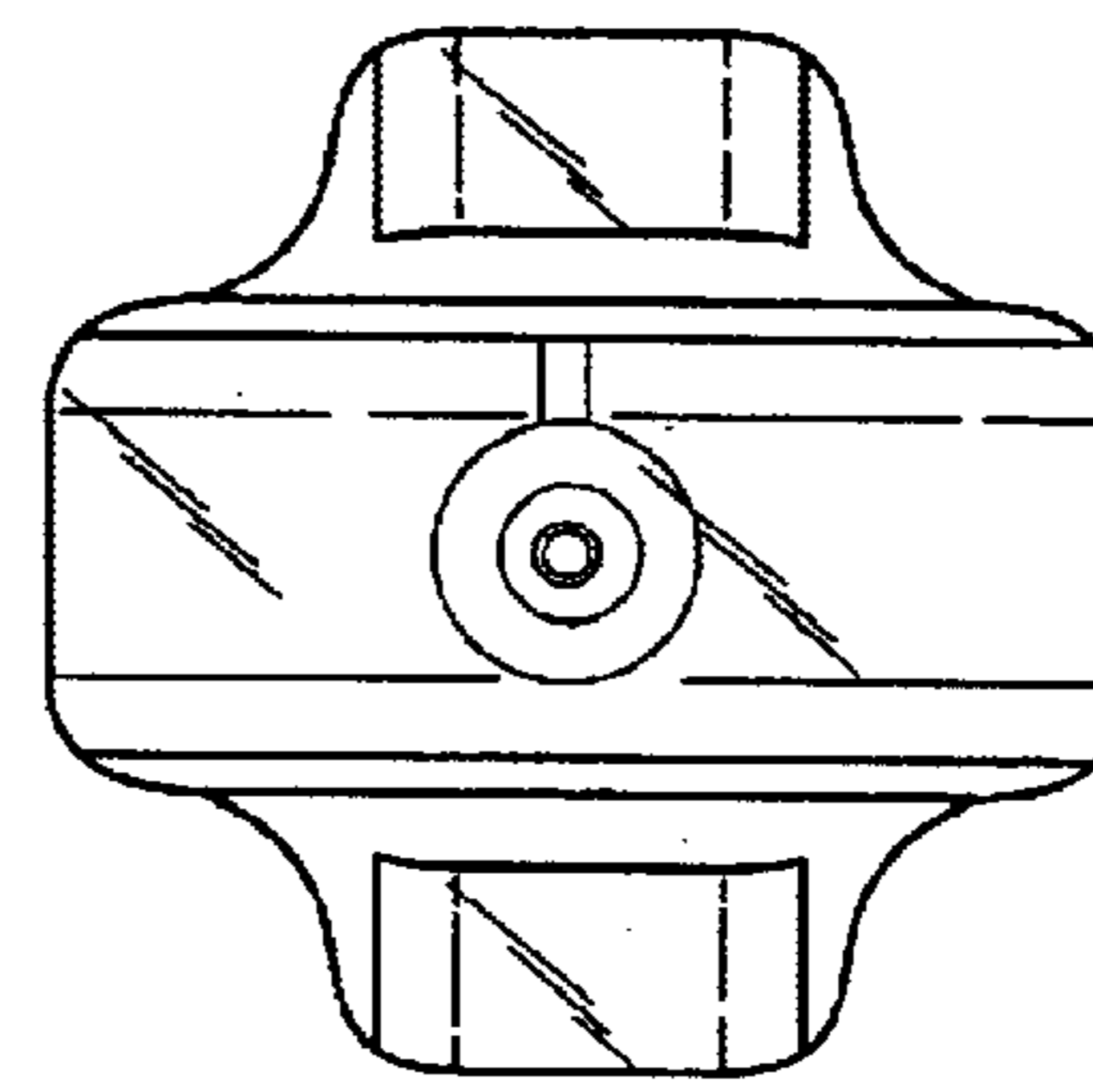

FIG. 6

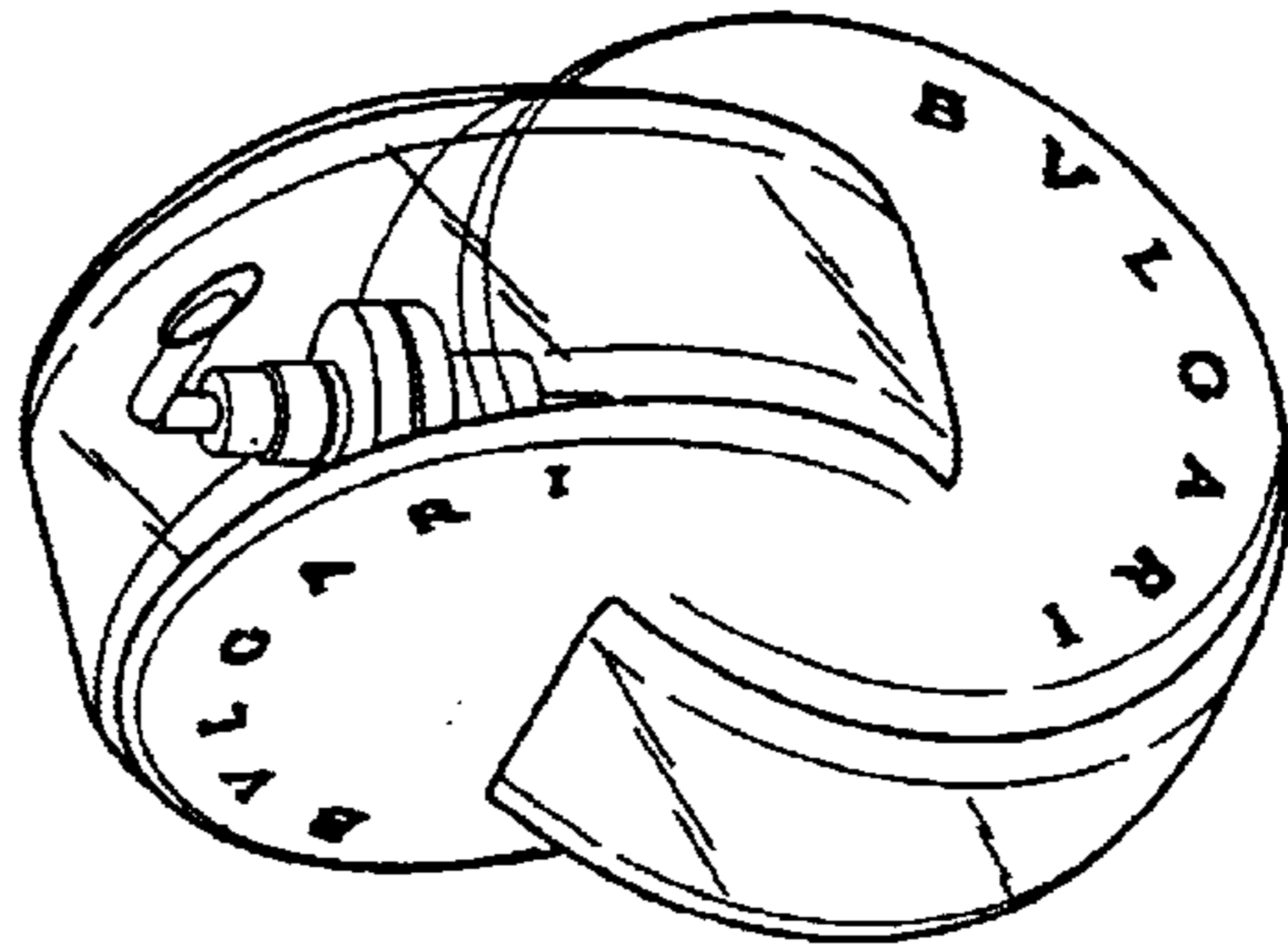

FIG. 7

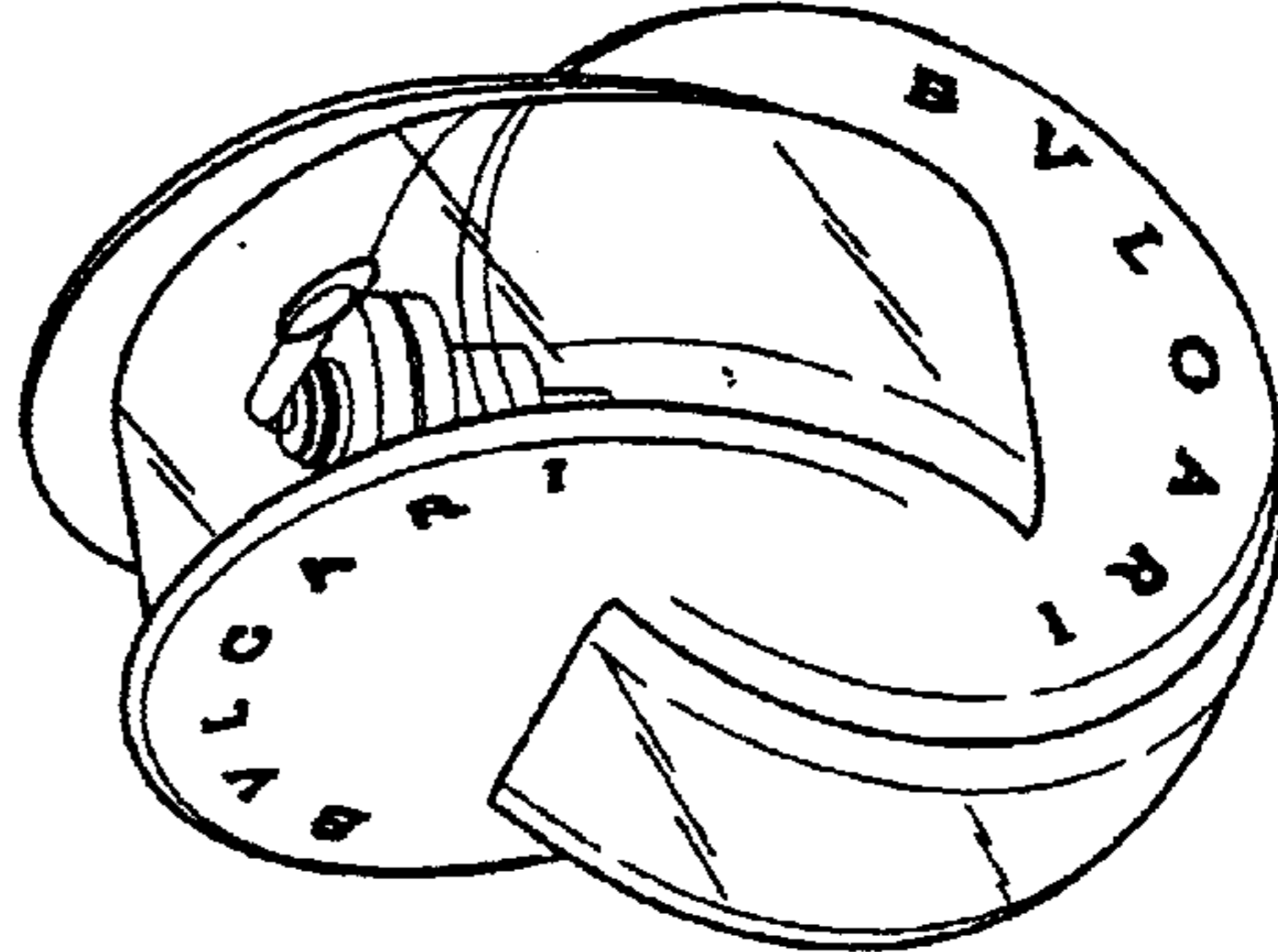

FIG. 8