



US00D491435S

(12) **United States Design Patent**
Junkers

(10) **Patent No.:** **US D491,435 S**

(45) **Date of Patent:** **** Jun. 15, 2004**

(54) **FLUID OPERATED WRENCH**

(76) **Inventor:** **John K. Junkers**, 8 Stonewall Rd.,
Saddle River, NJ (US) 07458

(**) **Term:** **14 Years**

(21) **Appl. No.:** **29/177,857**

(22) **Filed:** **Mar. 18, 2003**

(51) **LOC (7) Cl.** **08-04**

(52) **U.S. Cl.** **D8/61**

(58) **Field of Search** D8/61, 62, 63,
D8/67, 68, 69; 81/57.11, 57.13, 57.39,
464, 465, 466, 467, 469, 470; 173/13, 14,
47, 48, 168, 169, 170, 171; 310/50; 408/113,
124

(56) **References Cited**

U.S. PATENT DOCUMENTS

3,273,428	A	*	9/1966	Rudeke	81/464
4,513,645	A	*	4/1985	Grabovac et al.	81/57.39
4,619,160	A	*	10/1986	Meyer	81/57.39
4,706,527	A	*	11/1987	Junkers	81/57.39
4,805,496	A	*	2/1989	Wagner et al.	81/57.39
4,825,730	A	*	5/1989	Junkers	81/57.39
5,103,696	A	*	4/1992	Beuke	81/57.39
RE33,951	E	*	6/1992	Junkers	81/57.39

5,357,828	A	*	10/1994	Spirer	81/57.39
5,924,340	A	*	7/1999	Junkers	81/57.39
6,279,427	B1	*	8/2001	Francis	81/57.39
D465,394	S	*	11/2002	Junkers	D8/61

* cited by examiner

Primary Examiner—James Gandy

Assistant Examiner—Elizabeth Albert

(74) *Attorney, Agent, or Firm*—Michael J. Striker

(57) **CLAIM**

The ornamental design for a fluid operated wrench, as shown and described.

DESCRIPTION

FIG. 1 is a perspective view of a fluid operated wrench showing my new design;
 FIG. 2 is a top plan view thereof;
 FIG. 3 is a side view thereof, which is a mirror image of the opposite side thereof;
 FIG. 4 is a rear view thereof;
 FIG. 5 is a front view thereof; and,
 FIG. 6 is a bottom view thereof.

The broken lines showing environment in the drawings are for illustrative purposes only and form no part of the claimed design.

1 Claim, 6 Drawing Sheets

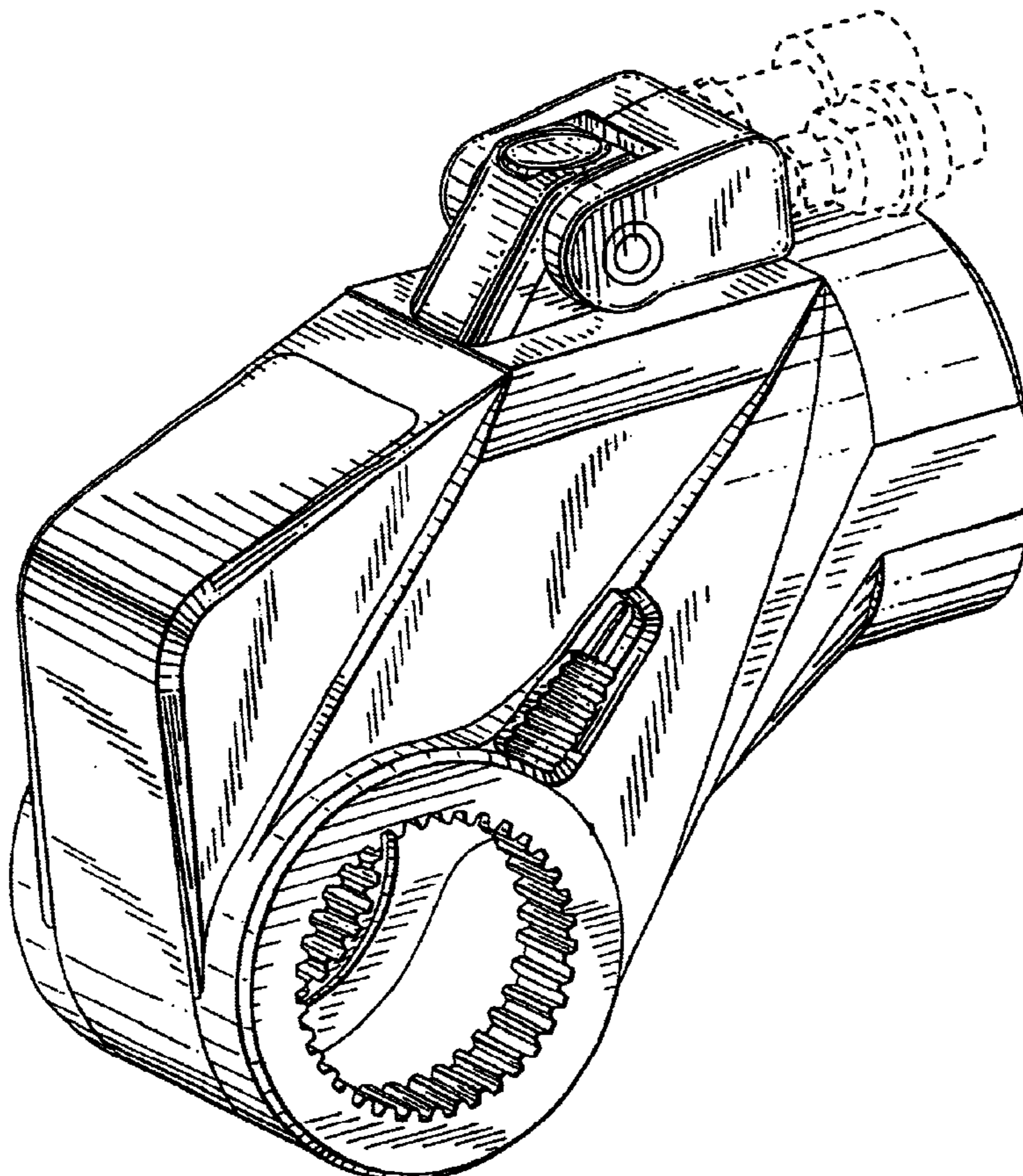

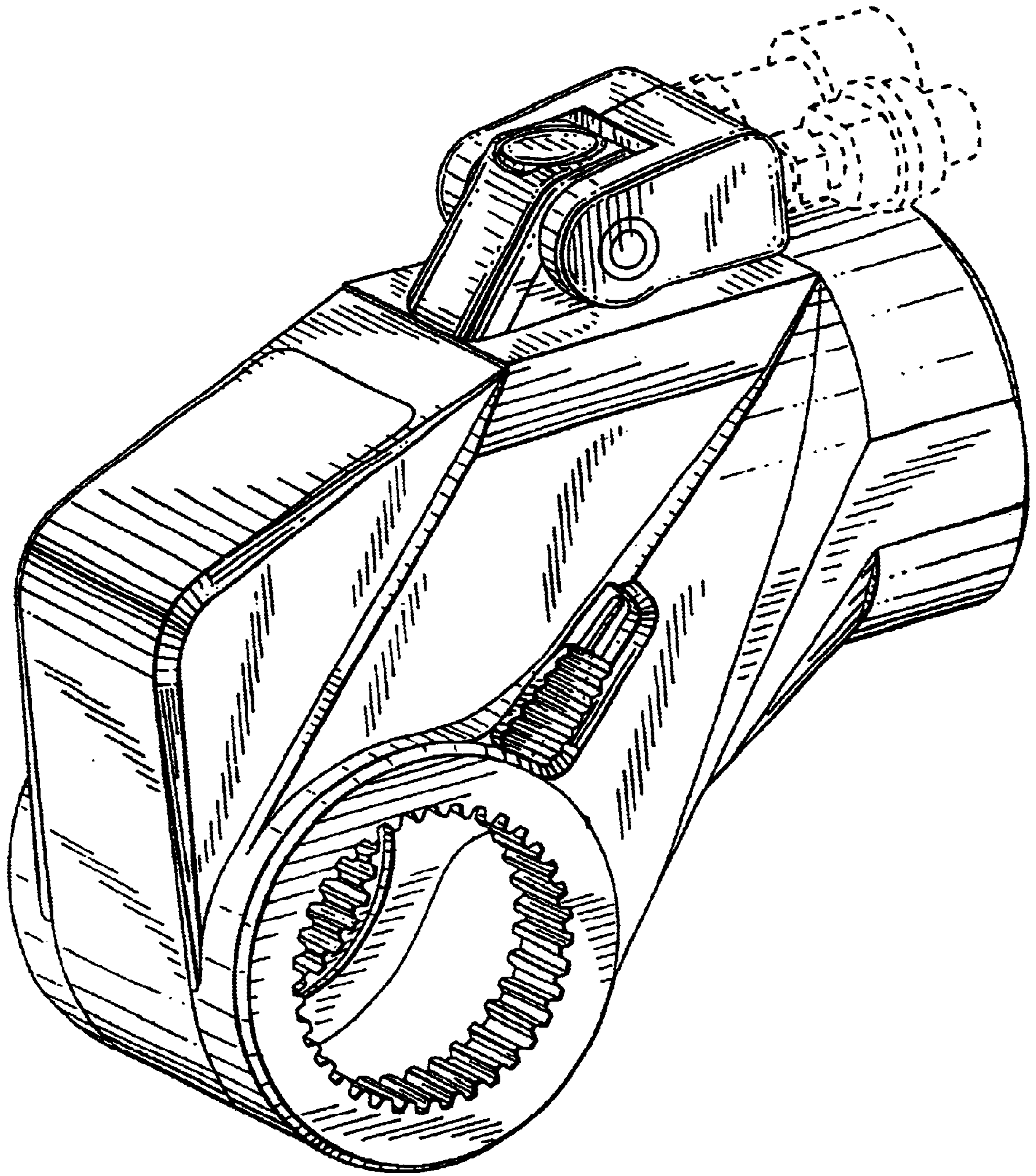

FIG. 1

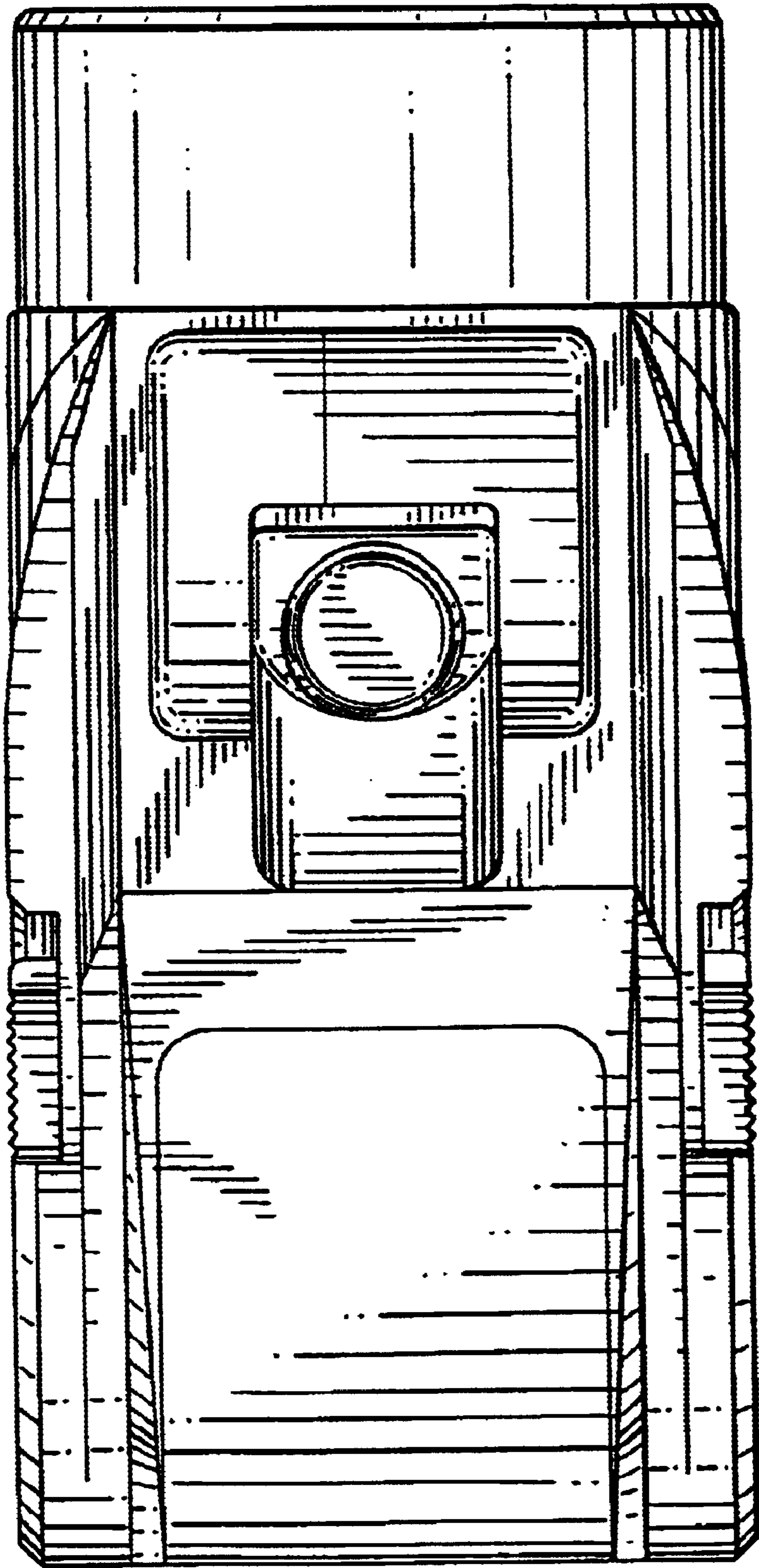

FIG. 2

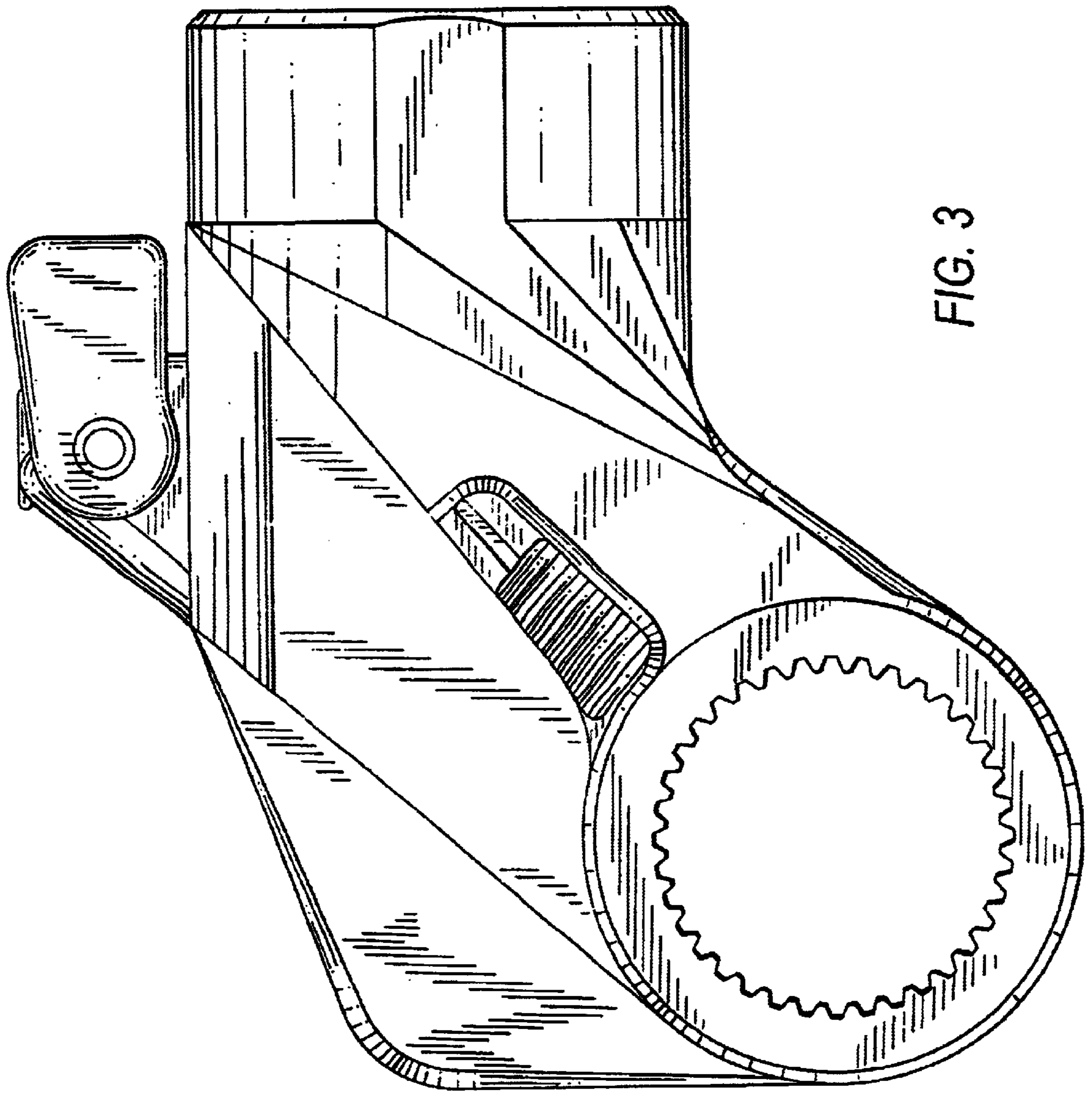

FIG. 3

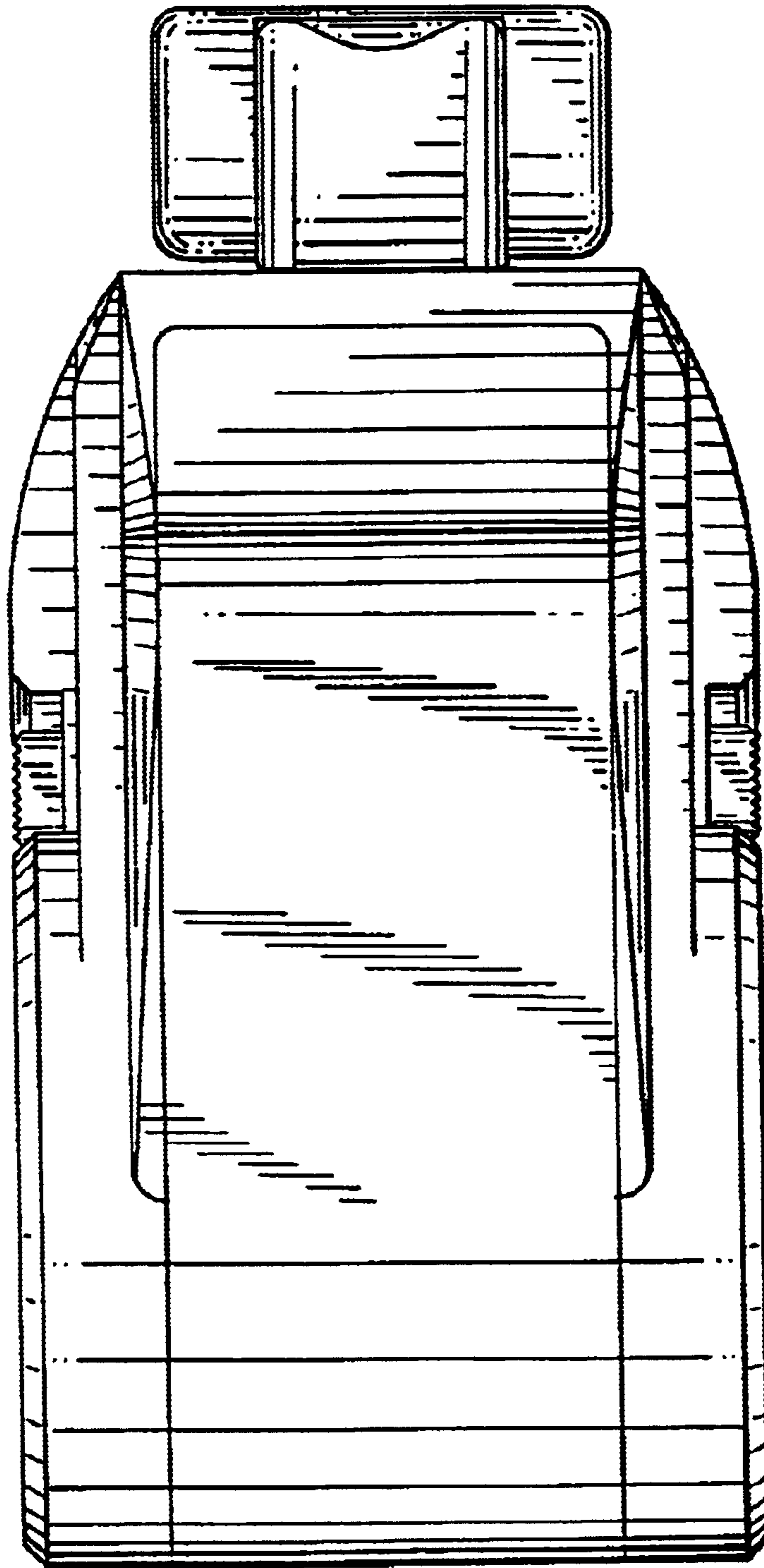

FIG. 4

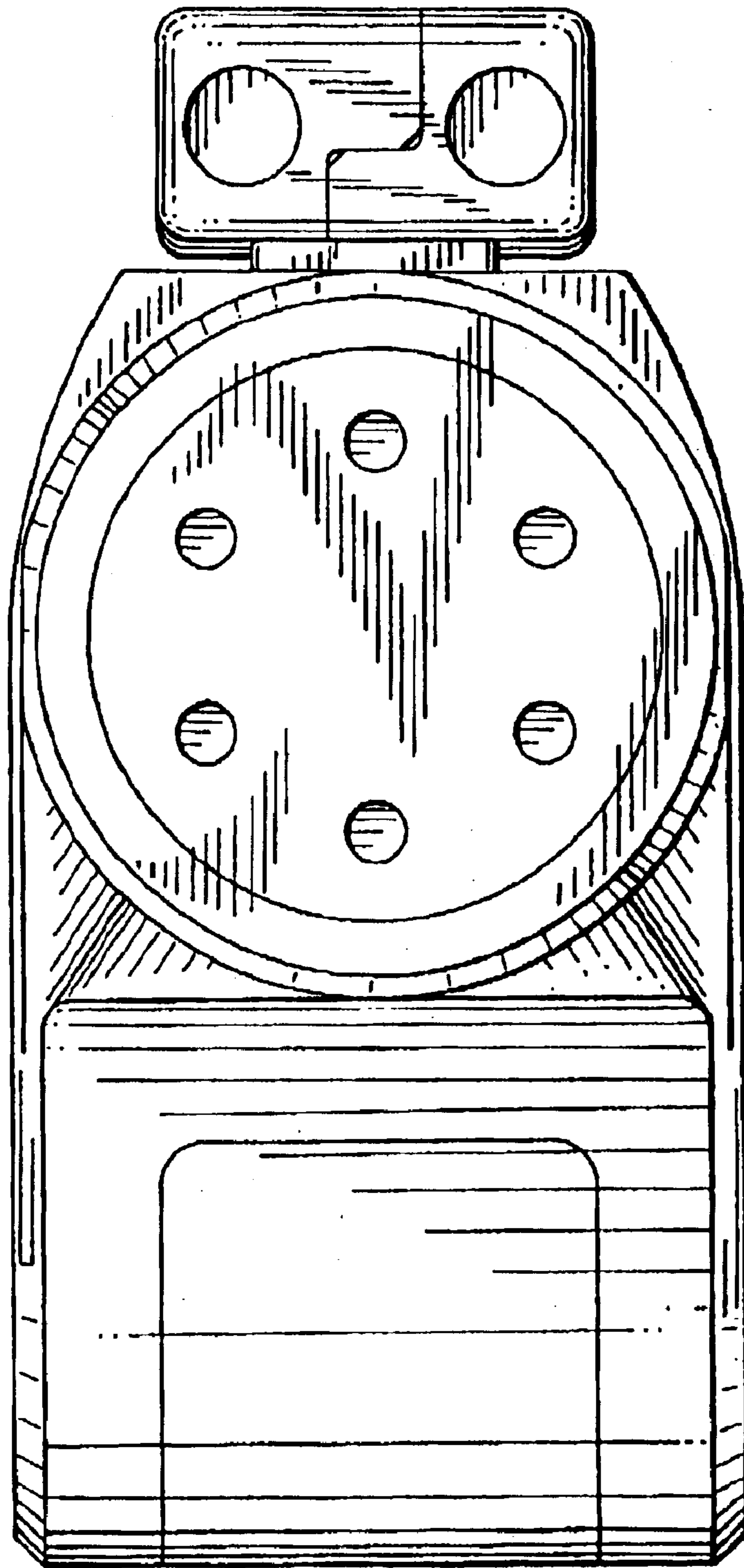

FIG. 5

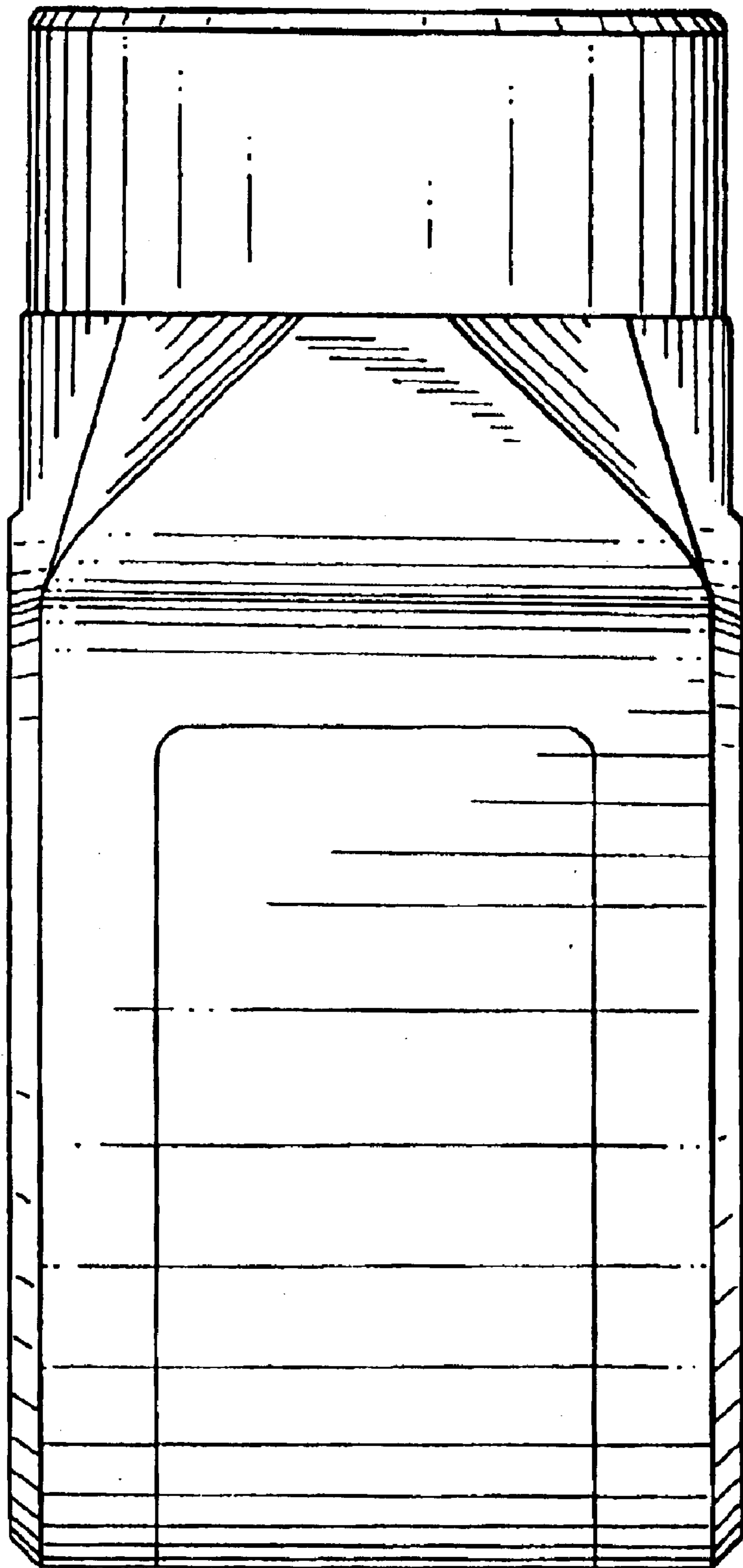

FIG. 6