



US00D491109S

(12) **United States Design Patent**
Walters

(10) **Patent No.:** **US D491,109 S**

(45) **Date of Patent:** **** Jun. 8, 2004**

(54) **VEHICLE**

(75) Inventor: **Mark Walters**, Royal Oak, MI (US)

(73) Assignee: **DaimlerChrysler Corporation**, Auburn Hills, MI (US)

(**) Term: **14 Years**

(21) Appl. No.: **29/173,768**

(22) Filed: **Jan. 6, 2003**

(51) **LOC (7) Cl.** **12-11**

(52) **U.S. Cl.** **D12/110**

(58) **Field of Search** D12/107, 110;
180/219, 220, 225, 227, 229; 296/78.1

(56) **References Cited**

U.S. PATENT DOCUMENTS

4,887,688 A * 12/1989 Horiike et al. 180/229
D396,433 S * 7/1998 Belker et al. D12/110

* cited by examiner

Primary Examiner—Alan P. Douglas

Assistant Examiner—Linda Brooks

(74) *Attorney, Agent, or Firm*—Ralph E. Smith

(57) **CLAIM**

The ornamental design for a vehicle, as shown and described.

DESCRIPTION

FIG. 1 is a front perspective view of a vehicle showing my new design;

FIG. 2 is a left side view thereof;

FIG. 3 is a rear perspective view thereof;

FIG. 4 is a front view thereof; and,

FIG. 5 is a rear view thereof.

It will be understood that dashed lines presented in the drawings are for illustration only, and do not form a part of the claimed design.

1 Claim, 4 Drawing Sheets

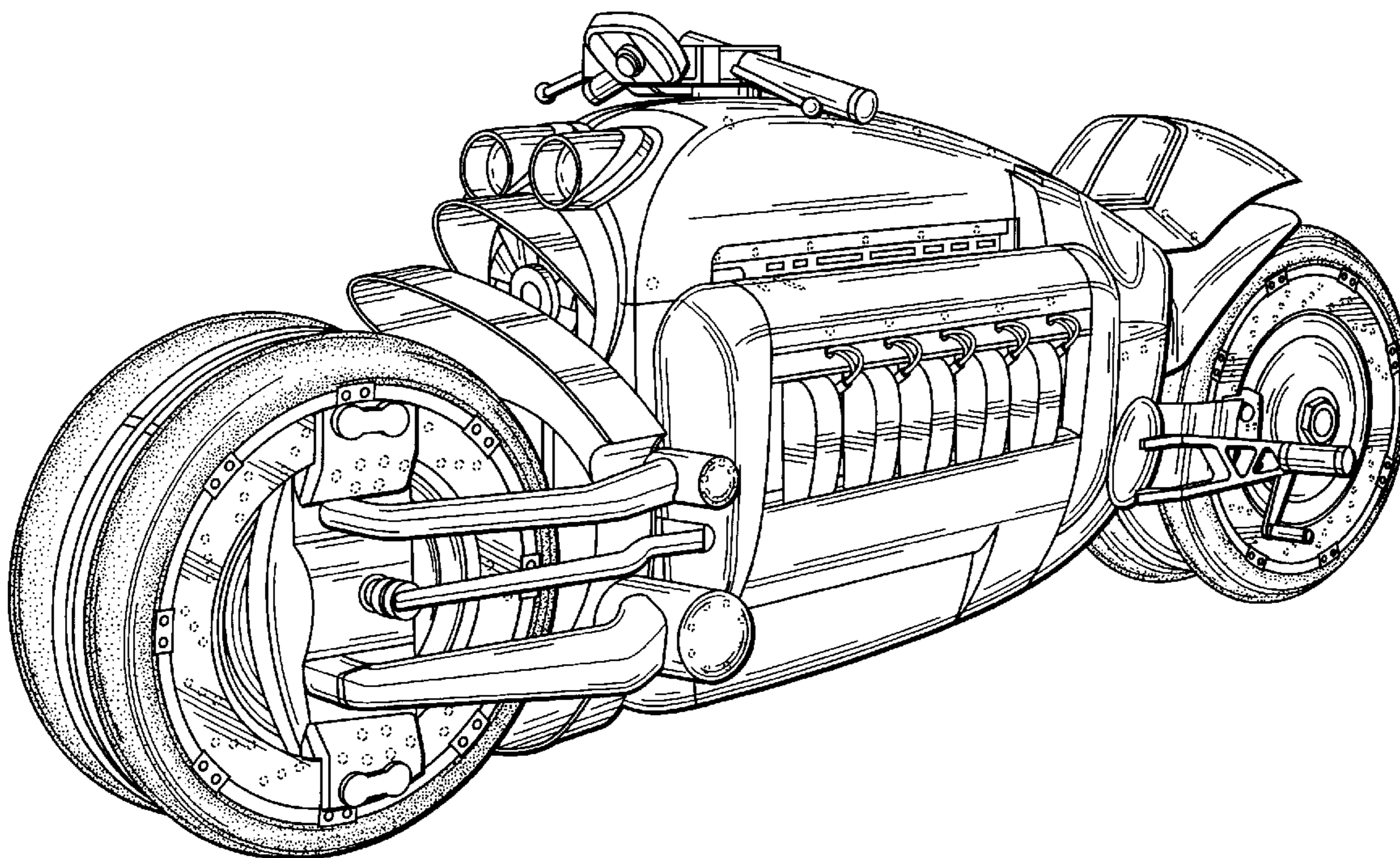

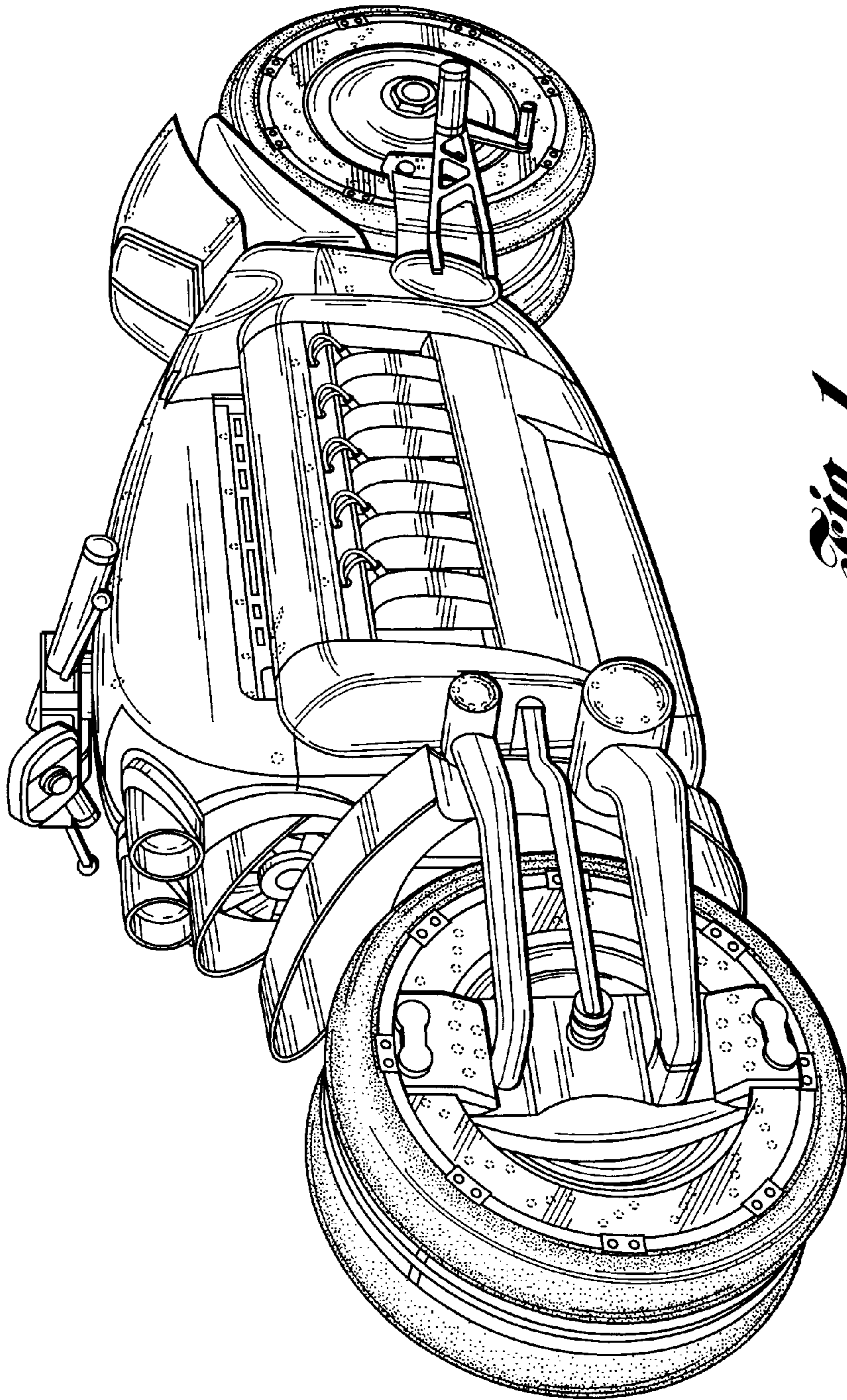

Fig. 1

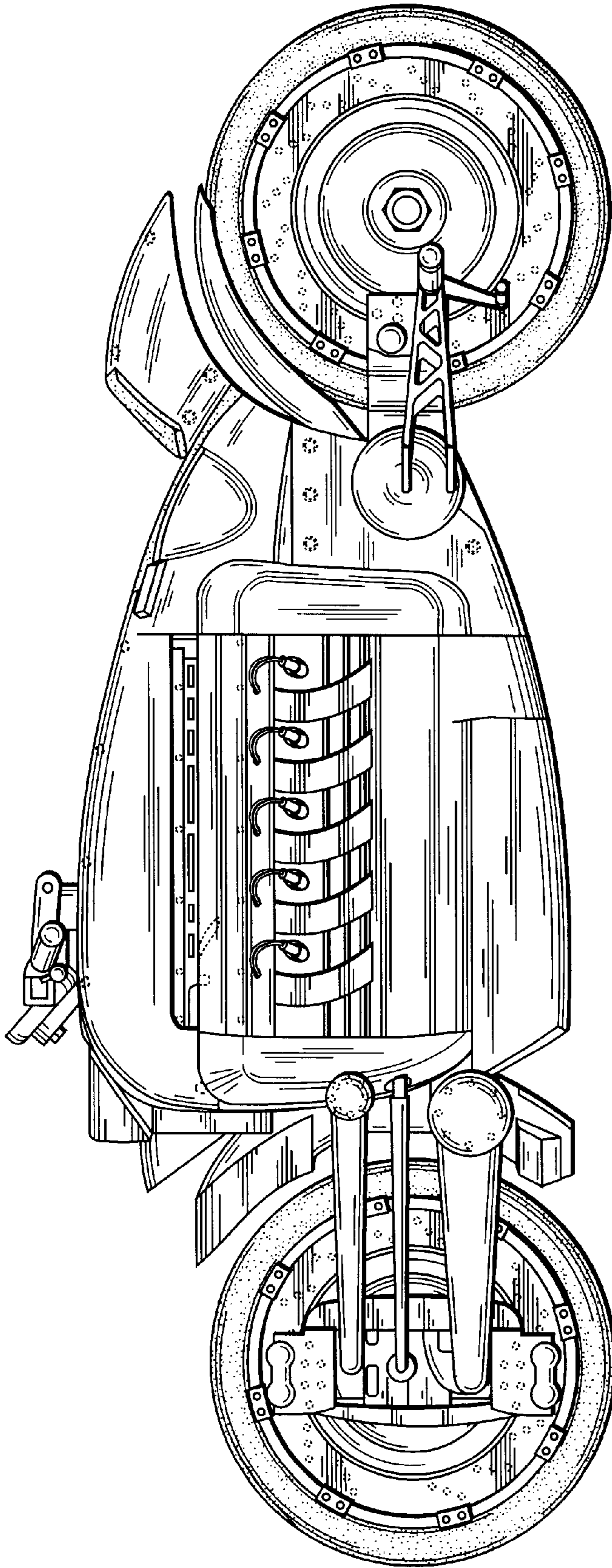

Fig. 2

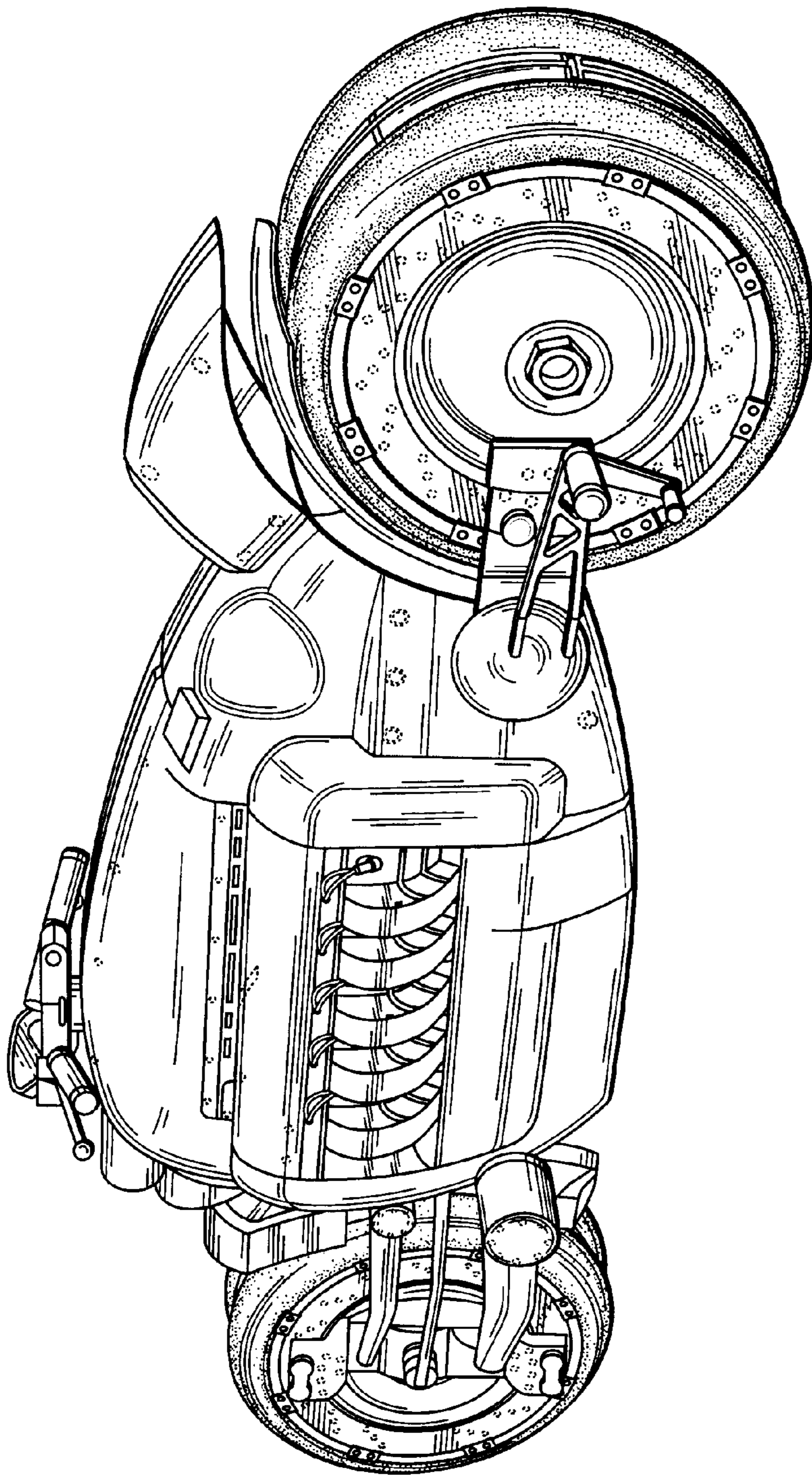

Fig. 3

Fig. 4

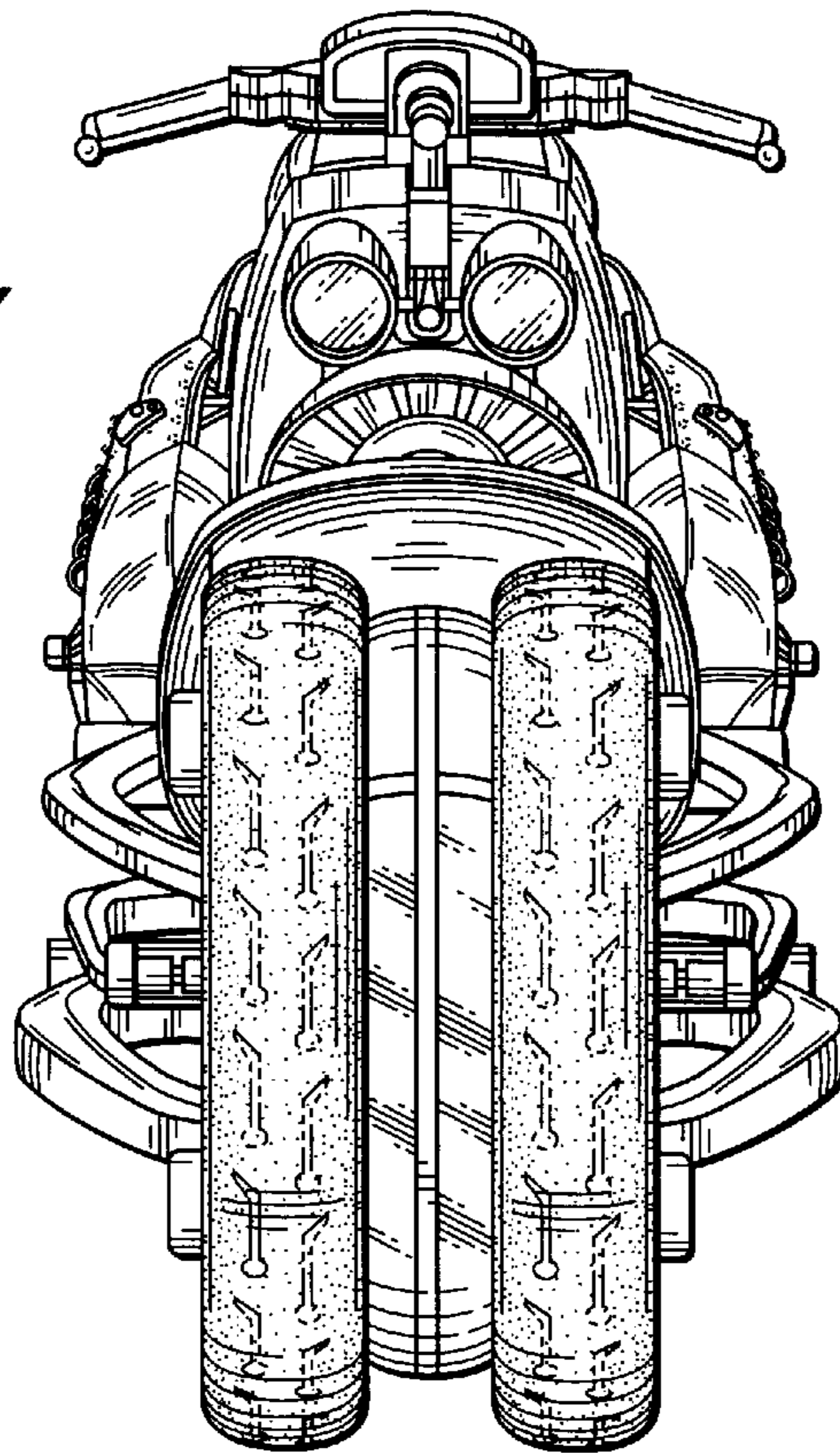

Fig. 5

